

BS ISO 13693-2:2015



BSI Standards Publication

# Irrigation equipment — Safety devices for chemigation

Part 2: Chemigation valve assemblies from DN 75 (3") to DN 350 (14")

**bsi.**

...making excellence a habit.™

**National foreword**

This British Standard is the UK implementation of ISO 13693-2:2015.

The UK participation in its preparation was entrusted to Technical Committee AGE/30, Irrigation and drainage equipment.

A list of organizations represented on this committee can be obtained on request to its secretary.

This publication does not purport to include all the necessary provisions of a contract. Users are responsible for its correct application.

© The British Standards Institution 2015. Published by BSI Standards Limited 2015

ISBN 978 0 580 80609 4

ICS 65.060.35

**Compliance with a British Standard cannot confer immunity from legal obligations.**

This British Standard was published under the authority of the Standards Policy and Strategy Committee on 28 February 2015.

**Amendments issued since publication**

Date	Text affected
------	---------------

---

---

---

**Irrigation equipment — Safety devices  
for chemigation —**

Part 2:  
**Chemigation valve assemblies from  
DN 75 (3") to DN 350 (14")**

*Matériel d'irrigation — Dispositifs de sécurité pour l'application de  
produits chimiques par irrigation —*

*Partie 2: Installations de vannes pour application de produits  
chimiques par irrigation de DN 75 (3") à DN 350 (14")*





**COPYRIGHT PROTECTED DOCUMENT**

© ISO 2015

All rights reserved. Unless otherwise specified, no part of this publication may be reproduced or utilized otherwise in any form or by any means, electronic or mechanical, including photocopying, or posting on the internet or an intranet, without prior written permission. Permission can be requested from either ISO at the address below or ISO's member body in the country of the requester.

ISO copyright office  
Case postale 56 • CH-1211 Geneva 20  
Tel. + 41 22 749 01 11  
Fax + 41 22 749 09 47  
E-mail [copyright@iso.org](mailto:copyright@iso.org)  
Web [www.iso.org](http://www.iso.org)

Published in Switzerland

# Contents

Page

<b>Foreword</b> .....	<b>iv</b>
<b>Introduction</b> .....	<b>v</b>
<b>1 Scope</b> .....	<b>1</b>
<b>2 Normative references</b> .....	<b>1</b>
<b>3 Terms and definitions</b> .....	<b>1</b>
<b>4 Design considerations</b> .....	<b>2</b>
4.1 General requirements.....	2
4.2 Specific requirements.....	3
<b>5 Performance requirements</b> .....	<b>4</b>
5.1 General.....	4
5.2 Permissible deviations of measuring devices.....	4
5.3 Mechanical strength of valve body assembly and components.....	4
5.3.1 Resistance to internal pressure.....	4
5.3.2 Test methods.....	5
5.4 Low pressure drain valve.....	5
5.5 Hydraulic characteristics.....	5
5.6 Vacuum relief valve.....	6
5.7 Elevated temperature tests.....	6
5.8 Endurance.....	6
5.8.1 Requirements.....	6
5.8.2 Tests.....	6
5.9 Acoustic test.....	6
<b>6 Conformity assessment</b> .....	<b>6</b>
6.1 General.....	6
6.2 Type tests.....	7
6.3 Control of production process and quality system.....	7
<b>7 Marking, technical documents, and packaging</b> .....	<b>7</b>
7.1 Marking.....	7
7.2 Technical documents.....	7
7.3 Packaging.....	7
<b>Bibliography</b> .....	<b>8</b>

## Foreword

ISO (the International Organization for Standardization) is a worldwide federation of national standards bodies (ISO member bodies). The work of preparing International Standards is normally carried out through ISO technical committees. Each member body interested in a subject for which a technical committee has been established has the right to be represented on that committee. International organizations, governmental and non-governmental, in liaison with ISO, also take part in the work. ISO collaborates closely with the International Electrotechnical Commission (IEC) on all matters of electrotechnical standardization.

The procedures used to develop this document and those intended for its further maintenance are described in the ISO/IEC Directives, Part 1. In particular the different approval criteria needed for the different types of ISO documents should be noted. This document was drafted in accordance with the editorial rules of the ISO/IEC Directives, Part 2 (see [www.iso.org/directives](http://www.iso.org/directives)).

Attention is drawn to the possibility that some of the elements of this document may be the subject of patent rights. ISO shall not be held responsible for identifying any or all such patent rights. Details of any patent rights identified during the development of the document will be in the Introduction and/or on the ISO list of patent declarations received (see [www.iso.org/patents](http://www.iso.org/patents)).

Any trade name used in this document is information given for the convenience of users and does not constitute an endorsement.

For an explanation on the meaning of ISO specific terms and expressions related to conformity assessment, as well as information about ISO's adherence to the WTO principles in the Technical Barriers to Trade (TBT) see the following URL: [Foreword - Supplementary information](#)

The committee responsible for this document is ISO/TC 23, *Tractors and machinery for agriculture and forestry*, Subcommittee SC 18, *Irrigation and drainage equipment and systems*.

ISO 13693 consists of the following parts, under the general title *Irrigation equipment — Safety devices for chemigation*:

- *Part 1: Small plastics valves for chemigation*
- *Part 2: Chemigation valve assemblies from DN 75 (3") to DN 350 (14")*

## Introduction

Chemigation is the practice of injecting chemicals into irrigation water for the purpose of distributing the chemicals onto crops. During the course of this activity, under certain hydraulic conditions, the chemicals being injected can migrate upstream into a well or other pressurized water supply and pollute that water source. A chemigation valve assembly has been developed to meet this need. The chemigation valve assembly is designed to meet the specific need and performance requirements as required to prohibit the migration of injected chemicals into irrigation wells, thereby polluting ground water supplies.

This part of ISO 13693 applies to a mainline check valve assembly in sizes from DN 75 (3") to DN 350 (14"), with related components, that is designed to permit full flow in the operational mode and stop backflow (back siphonage or back pressure) when the pipeline shuts down. The potential for backflow from back siphonage occurs as water tumbles back down the column pipe when the pump shuts down. The potential for backflow occurs when a positive pressure exists on the downstream end of the valve. The valve obturator is forced to the closed position by a pre-tensioned spring. A resilient cover on the obturator helps to seal the valve against very low pressures.

This chemigation valve assembly is included in a technical report (to be written) that specifies a complete chemigation safety system. This system features a chemical tank (fertilizers and chemicals), a chemical pump (positive displacement or Venturi), check valves, and interlocking safety shutdown controls. The system is designed to keep irrigation water from flooding the chemical tank and to shut the chemical system down when the irrigation pump shuts down or the irrigation system pressure has been reduced to a level where the injected chemical is not being uniformly distributed to the field. The functional requirements of the chemigation valve could possibly be provided by valves of a different design. The valve is not designed for use in potable water systems.





# Irrigation equipment — Safety devices for chemigation —

## Part 2:

# Chemigation valve assemblies from DN 75 (3") to DN 350 (14")

## 1 Scope

This part of ISO 13693 specifies the construction and performance requirement and test methods for metal-bodied chemigation valves with water at temperatures not exceeding 50 °C, which might contain fertilizers and chemicals of the types and concentration used in agriculture.

The valve is designed to prohibit backflow caused by either back pressure or back siphonage. It is not designed for use in potable water systems. It is not to be confused with other forms of backflow prevention devices including pressure vacuum breakers, double check valves, reduced pressure zone valves, or goose neck loops. This part of ISO 13693 specifies the minimum design, construction, and performance testing requirements for the chemigation valve assembly. The assembly consists of the following components:

- a valve body into which a spring-loaded check valve is mounted with a resilient disk cover on the sealing surface;
- a combination air release/vacuum relief valve located upstream of the check valve;
- a low pressure drain valve located upstream of the check valve;
- an inspection port located so as to permit visual and manual inspection of the valve working components.

## 2 Normative references

The following documents, in whole or in part, are normatively referenced in this document and are indispensable for its application. For dated references, only the edition cited applies. For undated references, the latest edition of the referenced document (including any amendments) applies.

ISO 9635-1:2014, *Agricultural irrigation equipment — Irrigation valves — Part 1: General requirements*

EN 1267:1999, *Industrial valves — Test of flow resistance using water as a test fluid*

## 3 Terms and definitions

For the purposes of this document, the following terms and definitions apply.

### 3.1

#### **chemigation valve**

valve featuring a chemical injection port and designed to prevent injected chemicals from moving upstream

### 3.2

#### **check valve**

valve which permits flow of water in one direction only

### 3.3

#### **air vent**

#### **vacuum relief valve**

valve which opens automatically to allow air from the atmosphere to enter a pipeline during drainage of the pipeline and/or venting of air to the atmosphere during pipeline filling

### 3.4

#### **low pressure drain valve**

spring-loaded valve which opens up at low pressure to provide drainage

### 3.5

#### **chemical injection port**

threaded port in a body of the chemigation valve to accommodate the injection of chemicals

### 3.6

#### **inspection port**

port in the body of a chemigation valve to allow for the manual and visual inspection of its internal components

### 3.7

#### **resilient cover**

elastomeric cover on the disk of a check valve

### 3.8

#### **chemigation valve body**

main part of a chemigation valve through which water flows, which houses the internals of the valve and which allows for connection to the piping system

## 4 Design considerations

### 4.1 General requirements

The valve is designed to prevent backflow of irrigation water that might contain fertilizers and other chemicals of the types and concentrations commonly used in pressurized agricultural irrigation systems. The valve is mounted in pipelines using a flange or other suitable connections. The valve must prevent backflow that results from both back siphonage and back pressure conditions present in the pipeline. See [Figure 1](#).

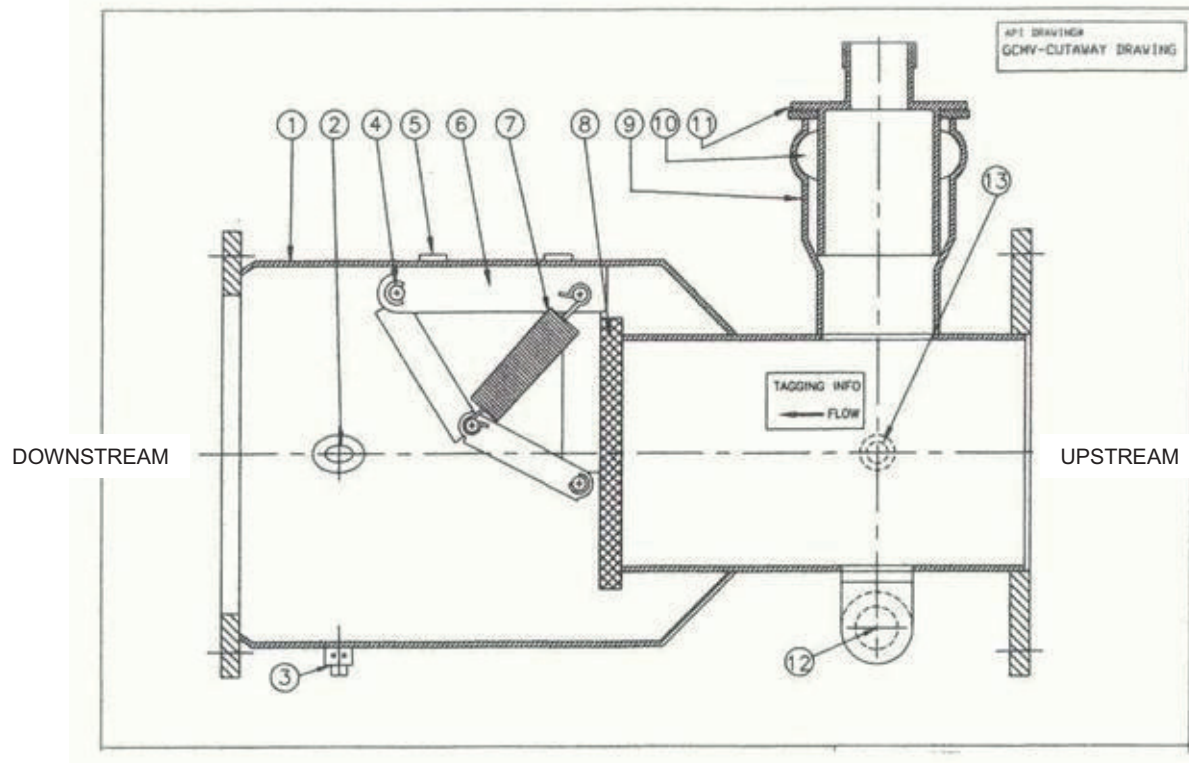

**Figure 1 — Cutaway drawing of a chemigation valve body assembly**

**Key**

- 1 valve body (metallic)
- 2 threaded connection
- 3 manual drain port
- 4 linkage mounting pin
- 5 linkage mounting bolt
- 6 linkage mounting frame
- 7 spring
- 8 check valve resilient sealing surface
- 9 female coupling
- 10 gasket
- 11 male coupling to mount the air vent/vacuum relief valve
- 12 threaded connection to mount the low pressure drain valve
- 13 threaded port to mount the pressure gauge (optional)

**4.2 Specific requirements**

Chemigation valve assemblies shall be designed in accordance with the following requirements.

- a) Valve ends shall be designed for ease of installation and removal in piping systems and provide for a watertight sealing of the connecting joints.
- b) The check valve assembly shall provide for full flow in the open position and a watertight seal in the reverse flow direction.
- c) The air vent/vacuum relief valve shall function as an air vent on pump start-up and as a vacuum relief valve when the pump is shut down.

- d) The low pressure drain valve shall open at atmospheric pressure and remain open until the pump is started and a minimum pressure of 15 kPa has been reached.
- e) The inspection port shall be attached to the valve body mechanically (hand removable) to accommodate the internal pressure test without leakage. The inspection port shall have a minimum open clearance of 115 mm and allow for manual and visual inspection of the check valve seat and resilient sealing surface.
- f) The injection port shall be located downstream of the check valve and be designed to facilitate complete mixing of the added chemicals with the irrigation water and minimize the contact between the chemicals and the valve body.
- g) All functioning components shall be removable for inspection or replacement.
- h) The valve shall have a stated maximum flow rate based on limiting the average velocity through the valve body to 3,0 m/s. The average flow rate shall be calculated for a pipe of equivalent size.
- i) The valve body and components shall be designed to resist chemical attack.
- j) The low pressure drain valve shall have a nominal body internal flow passage diameter not less than 15 mm.

Chemigation valves shall be designed in accordance with additional requirements given in ISO 9635-1:2014, Clause 4.

## 5 Performance requirements

### 5.1 General

Performance tests shall be carried out on the valve assembly in accordance with the manufacturer's technical documents.

### 5.2 Permissible deviations of measuring devices

In the absence of any particular specification, the accuracy of measurements shall be as follows:

- flow rate and pressure  $\pm 2$  % of the specified value;
- temperature:  $23\text{ °C} \pm 5\text{ °C}$ ;
- time:  $\pm 1$  % of the specified value.

The measuring devices shall be calibrated according to the existing calibration rules in the country concerned.

### 5.3 Mechanical strength of valve body assembly and components

#### 5.3.1 Resistance to internal pressure

- a) For test method [5.3.2 d\)](#) only, the chemigation valve assembly shall be tested in the horizontal and vertical (inlet flange up) position. Neither visual permanent deformation nor rupture of the body, internal components, or assembled components shall occur. The pressure tests defined by [5.3.2 c\)](#) and [d\)](#) shall result in a leakage rate no greater than 0,3 ml/min. During pressure testing, water must be introduced slowly to limit pressure surges.

Neither visual permanent deformation nor rupture of the body, internal components, or assembled components shall occur.

### 5.3.2 Test methods

- a) Prepare the valve assembly by plugging the injection port (2), installing the low pressure drain valve (12), the air vent/vacuum relief valve, and male coupling clamping ring. Fit the valve assembly with blind flanges mating to the inlet and outlet flanges. Subject the valve assembly to a pressure of 1 MPa for a period of 5 min. Test pressure to be introduced through a threaded port (13).
- b) Prepare the valve body by removing the air vent/vacuum relief valve and low pressure drain valve and plugging their ports. Fit the valve body with blind flanges bolted to the inlet and outlet flanges. Subject the valve body to a pressure of 2,5 MPa for a period of 5 min. Test pressure to be introduced through threaded ports (2) and (13).
- c) Prepare the check valve body by fitting the outlet flange with a mating blind flange. Subject the check valve body to a pressure of 1,5 MPa for a period of 5 min. Introduce the test pressure through the threaded connection (2).
- d) Prepare the check valve body by fitting the outlet flange with a mating blind flange. Subject the check valve body to a low pressure of 15 kPa for 16 h. Test pressure to be introduced through the threaded connection (2).

NOTE A clear piezometer is suggested with a water column height of 1,5 m above the check valve disk centerline.

### 5.4 Low pressure drain valve

The low pressure drain valve shall be tested to have a closing pressure of not more than 15 kPa. Test the valve by subjecting it to a vertical static column of water. The valve shall close when the vertical column of water is greater than  $1,5 \text{ m} \pm 0,05 \text{ m}$ . The valve shall have a nominal body internal flow passage diameter of at least 15 mm.

### 5.5 Hydraulic characteristics

Requirement shall be in accordance with ISO 9635-1:2014, 5.4. The characteristic given by the manufacturer shall be the head loss as a function of flow.

When measured with a test installation in accordance with EN 1267:1999, Clause 4, the head loss shall not be more than 1,1 times the value indicated by the manufacturer. Head loss testing is not required for chemigation valves greater in size than DN 300.

## 5.6 Vacuum relief valve

The vacuum relief valve must have a minimum vacuum relief capacity at a vacuum of 15,0 kPa as shown in [Table 1](#).

**Table 1 — Vacuum relief valve maximum required capacity**

<b>Pump column, pipe size DN</b>	<b>Minimum vacuum relief capacity SCMM<sup>a, b</sup></b>
DN 75	5,6
DN 100	9,6
DN 125	15,1
DN 150	21,9
DN 200	38,0
DN 250	59,8
DN 300	85,8
DN 350	104,7

<sup>a</sup> Cubic meters per minute at standard atmospheric condition.

<sup>b</sup> Reference to manufacturer's test literature is satisfactory in meeting this requirement.

## 5.7 Elevated temperature tests

The chemigation valve assembly shall meet the testing requirements specified in [5.3.2](#) a) and c) when tested with water at a temperature of 50 °C ± 5 °C.

## 5.8 Endurance

### 5.8.1 Requirements

- At the conclusion of the cycle testing period, the chemigation valve shall pass the pressure tests as defined in [5.3.1](#) c) and [5.3.1](#) d).
- At the conclusion of the testing as required by [5.8.2](#) a), the valve shall be disassembled and the resilient sealing surface inspected for signs of damage and signs of failure to remain bonded to the check valve disk.

### 5.8.2 Tests

- The chemigation valve shall be hydraulically cycled 10 000 times using a flow rate equivalent to 50 % of the stated maximum flow rate (see [Clause 4](#)) and a back pressure of 30 kPa. Conduct this test using water at 23 °C ± 5 °C.

## 5.9 Acoustic test

There is no testing requirement relative to acoustic testing.

## 6 Conformity assessment

### 6.1 General

Requirement shall be in accordance with ISO 9635-1:2014, 6.1.

## 6.2 Type tests

Requirement shall be in accordance with ISO 9635-1:2014, 6.2. The type tests to be performed shall be those given in ISO 9635-1:2014, Table 2. They shall take place with the valve in the horizontal position.

## 6.3 Control of production process and quality system

Requirement shall be in accordance with ISO 9635-1:2014, 6.3. The production control tests in ISO 9635-1:2014, Table 2 are informative.

The conformity testing for the standard can be conducted in any order that suits the testing agency. Tests must be executed on a single chemigation valve assembly.

## 7 Marking, technical documents, and packaging

### 7.1 Marking

The chemigation valve assembly shall be clearly marked with a fixed identification plate giving the following information:

- arrow indicating the normal direction of flow;
- nominal pressure rating (PN);
- valve size (DN);
- valve part number;
- manufacturer's reference;
- reference to the present standard.

### 7.2 Technical documents

Technical documents supplied with each valve shall address the following design and installation considerations:

- head loss as a function of flow rate;
- corrosion resistance of the valve components (valve body, elastic cover, linkage components, automatic drain valve, and air and vacuum relief valve);
- safety recommendation associated with the manual inspection of the internals;
- disposal of the discharge from the automatic drain valve;
- proper location of the valve relative to other irrigation and chemical injection system components;
- rules and regulations as they exist in the location where the valve is being used;
- maximum flow rate.

### 7.3 Packaging

The chemigation valve assembly shall be protected from time of manufacture and assembly to installation against mechanical damage and outside contamination.

## Bibliography

- [1] ISO 7-1:1994, *Pipe threads where pressure-tight joints are made on the threads — Part 1: Dimensions, tolerances and designation*
- [2] ISO 7005-1:2011, *Pipe flanges — Part 1: Steel flanges for industrial and general service piping systems*









# British Standards Institution (BSI)

BSI is the national body responsible for preparing British Standards and other standards-related publications, information and services.

BSI is incorporated by Royal Charter. British Standards and other standardization products are published by BSI Standards Limited.

## About us

We bring together business, industry, government, consumers, innovators and others to shape their combined experience and expertise into standards-based solutions.

The knowledge embodied in our standards has been carefully assembled in a dependable format and refined through our open consultation process. Organizations of all sizes and across all sectors choose standards to help them achieve their goals.

## Information on standards

We can provide you with the knowledge that your organization needs to succeed. Find out more about British Standards by visiting our website at [bsigroup.com/standards](http://bsigroup.com/standards) or contacting our Customer Services team or Knowledge Centre.

## Buying standards

You can buy and download PDF versions of BSI publications, including British and adopted European and international standards, through our website at [bsigroup.com/shop](http://bsigroup.com/shop), where hard copies can also be purchased.

If you need international and foreign standards from other Standards Development Organizations, hard copies can be ordered from our Customer Services team.

## Subscriptions

Our range of subscription services are designed to make using standards easier for you. For further information on our subscription products go to [bsigroup.com/subscriptions](http://bsigroup.com/subscriptions).

With **British Standards Online (BSOL)** you'll have instant access to over 55,000 British and adopted European and international standards from your desktop. It's available 24/7 and is refreshed daily so you'll always be up to date.

You can keep in touch with standards developments and receive substantial discounts on the purchase price of standards, both in single copy and subscription format, by becoming a **BSI Subscribing Member**.

**PLUS** is an updating service exclusive to BSI Subscribing Members. You will automatically receive the latest hard copy of your standards when they're revised or replaced.

To find out more about becoming a BSI Subscribing Member and the benefits of membership, please visit [bsigroup.com/shop](http://bsigroup.com/shop).

With a **Multi-User Network Licence (MUNL)** you are able to host standards publications on your intranet. Licences can cover as few or as many users as you wish. With updates supplied as soon as they're available, you can be sure your documentation is current. For further information, email [bsmusales@bsigroup.com](mailto:bsmusales@bsigroup.com).

## BSI Group Headquarters

389 Chiswick High Road London W4 4AL UK

## Revisions

Our British Standards and other publications are updated by amendment or revision.

We continually improve the quality of our products and services to benefit your business. If you find an inaccuracy or ambiguity within a British Standard or other BSI publication please inform the Knowledge Centre.

## Copyright

All the data, software and documentation set out in all British Standards and other BSI publications are the property of and copyrighted by BSI, or some person or entity that owns copyright in the information used (such as the international standardization bodies) and has formally licensed such information to BSI for commercial publication and use. Except as permitted under the Copyright, Designs and Patents Act 1988 no extract may be reproduced, stored in a retrieval system or transmitted in any form or by any means – electronic, photocopying, recording or otherwise – without prior written permission from BSI. Details and advice can be obtained from the Copyright & Licensing Department.

## Useful Contacts:

### Customer Services

**Tel:** +44 845 086 9001

**Email (orders):** [orders@bsigroup.com](mailto:orders@bsigroup.com)

**Email (enquiries):** [cservices@bsigroup.com](mailto:cservices@bsigroup.com)

### Subscriptions

**Tel:** +44 845 086 9001

**Email:** [subscriptions@bsigroup.com](mailto:subscriptions@bsigroup.com)

### Knowledge Centre

**Tel:** +44 20 8996 7004

**Email:** [knowledgecentre@bsigroup.com](mailto:knowledgecentre@bsigroup.com)

### Copyright & Licensing

**Tel:** +44 20 8996 7070

**Email:** [copyright@bsigroup.com](mailto:copyright@bsigroup.com)



...making excellence a habit.™