

BS ISO 13583-1:2015



BSI Standards Publication

Centrifugally cast steel and alloy products

Part 1: General testing and tolerances

bsi.

...making excellence a habit.™

National foreword

This British Standard is the UK implementation of ISO 13583-1:2015. It supersedes BS ISO 13583-1:2000 which is withdrawn.

The UK participation in its preparation was entrusted to Technical Committee ISE/111, Steel Castings and Forgings.

A list of organizations represented on this committee can be obtained on request to its secretary.

This publication does not purport to include all the necessary provisions of a contract. Users are responsible for its correct application.

© The British Standards Institution 2015.
Published by BSI Standards Limited 2015

ISBN 978 0 580 76502 5

ICS 77.140.80

Compliance with a British Standard cannot confer immunity from legal obligations.

This British Standard was published under the authority of the Standards Policy and Strategy Committee on 30 September 2015.

Amendments/corrigenda issued since publication

Date	Text affected
------	---------------

INTERNATIONAL
STANDARD

ISO
13583-1

Second edition
2015-09-15

**Centrifugally cast steel and alloy
products —**

**Part 1:
General testing and tolerances**

*Produits en acier et alliages moulés par centrifugation —
Partie 1: Conditions générales d'essais et tolérances*



Reference number
ISO 13583-1:2015(E)

© ISO 2015



COPYRIGHT PROTECTED DOCUMENT

© ISO 2015, Published in Switzerland

All rights reserved. Unless otherwise specified, no part of this publication may be reproduced or utilized otherwise in any form or by any means, electronic or mechanical, including photocopying, or posting on the internet or an intranet, without prior written permission. Permission can be requested from either ISO at the address below or ISO's member body in the country of the requester.

ISO copyright office
Ch. de Blandonnet 8 • CP 401
CH-1214 Vernier, Geneva, Switzerland
Tel. +41 22 749 01 11
Fax +41 22 749 09 47
copyright@iso.org
www.iso.org

Contents

Page

Foreword	iv
1 Scope	1
2 Normative references	1
3 Terms and definitions	1
4 Materials	3
5 Supply	3
6 Mechanical tests	3
7 Surface finish requirements	4
8 Minimum sound wall (MSW) thickness and soundness	4
9 Dimensional and shape tolerances	4
9.1 General.....	4
9.2 Length.....	4
9.3 Straightness.....	4
9.4 Outside and inside diameters.....	5
10 Inspection procedures and standards of acceptance	6
11 Production welding	6
12 Supplementary requirements	6
12.1 General.....	6
12.2 Pressure test.....	7
12.3 Elevated temperature test.....	7
12.4 Acid etch ring test.....	7
12.5 Magnetic particle test.....	7
12.6 Ferrite determination.....	7
12.7 Corrosion testing.....	7
12.8 Eddy current testing.....	7
12.9 Radiography.....	7
12.10 Ultrasonic testing.....	7

Foreword

ISO (the International Organization for Standardization) is a worldwide federation of national standards bodies (ISO member bodies). The work of preparing International Standards is normally carried out through ISO technical committees. Each member body interested in a subject for which a technical committee has been established has the right to be represented on that committee. International organizations, governmental and non-governmental, in liaison with ISO, also take part in the work. ISO collaborates closely with the International Electrotechnical Commission (IEC) on all matters of electrotechnical standardization.

The procedures used to develop this document and those intended for its further maintenance are described in the ISO/IEC Directives, Part 1. In particular the different approval criteria needed for the different types of ISO documents should be noted. This document was drafted in accordance with the editorial rules of the ISO/IEC Directives, Part 2 (see www.iso.org/directives).

Attention is drawn to the possibility that some of the elements of this document may be the subject of patent rights. ISO shall not be held responsible for identifying any or all such patent rights. Details of any patent rights identified during the development of the document will be in the Introduction and/or on the ISO list of patent declarations received (see www.iso.org/patents).

Any trade name used in this document is information given for the convenience of users and does not constitute an endorsement.

For an explanation on the meaning of ISO specific terms and expressions related to conformity assessment, as well as information about ISO's adherence to the WTO principles in the Technical Barriers to Trade (TBT) see the following URL: [Foreword - Supplementary information](#)

The committee responsible for this document is ISO/TC 17, *Steel*, Subcommittee SC 11, *Steel castings*.

This second edition cancels and replaces the first edition (ISO 13583-1:2000), which has been technically revised with the following changes:

- in [Clause 2](#), the normative references were replaced with superseding International Standards;
- the former 8.2 having been deleted, the original subclause 8.3 was renumbered [8.2](#);
- [10.1.1](#) was revised;
- [10.1.2](#) was revised.

ISO 13583 consists of the following parts, under the general title *Centrifugally cast steel and alloy products*:

- *Part 1: General testing and tolerances*
- *Part 2: Materials*

Centrifugally cast steel and alloy products —

Part 1: General testing and tolerances

1 Scope

This part of ISO 13583 specifies the requirements for horizontal and vertical centrifugally cast steel and alloy products to be used in the following applications:

- a) heat resisting;
- b) corrosion resisting;
- c) general engineering.

2 Normative references

The following documents, in whole or in part, are normatively referenced in this document and are indispensable for its application. For dated references, only the edition cited applies. For undated references, the latest edition of the referenced document (including any amendments) applies.

ISO 3651-1, *Determination of resistance to intergranular corrosion of stainless steels — Part 1: Austenitic and ferritic-austenitic (duplex) stainless steels — Corrosion test in nitric acid medium by measurement of loss in mass (Huey test)*

ISO 3651-2, *Determination of resistance to intergranular corrosion of stainless steels — Part 2: Ferritic, austenitic and ferritic-austenitic (duplex) stainless steels — Corrosion test in media containing sulfuric acid*

ISO 4986, *Steel castings — Magnetic particle inspection*

ISO 4987, *Steel castings — Liquid penetrant inspection*

ISO 4990, *Steel castings — General technical delivery requirements*

ISO 4992-1, *Steel castings — Ultrasonic examination — Part 1: Steel castings for general purposes*

ISO 4992-2, *Steel castings — Ultrasonic examination — Part 2: Steel castings for highly stressed components*

ISO 4993, *Steel castings — Radiographic inspection*

ISO 6892-1, *Metallic materials — Tensile testing — Part 1: Method of test at room temperature*

ISO 6892-2, *Metallic materials — Tensile testing — Part 2: Method of test at elevated temperature*

ISO 13520, *Determination of ferrite content in austenitic stainless steel castings*

3 Terms and definitions

For the purposes of this document, the following terms and definitions apply.

3.1
minimum sound wall thickness
MSW

thickness which remains when all the porosity and roughness associated with the internal and external cast surfaces have been removed by machining

Note 1 to entry: See [Figures 1](#) and [2](#).

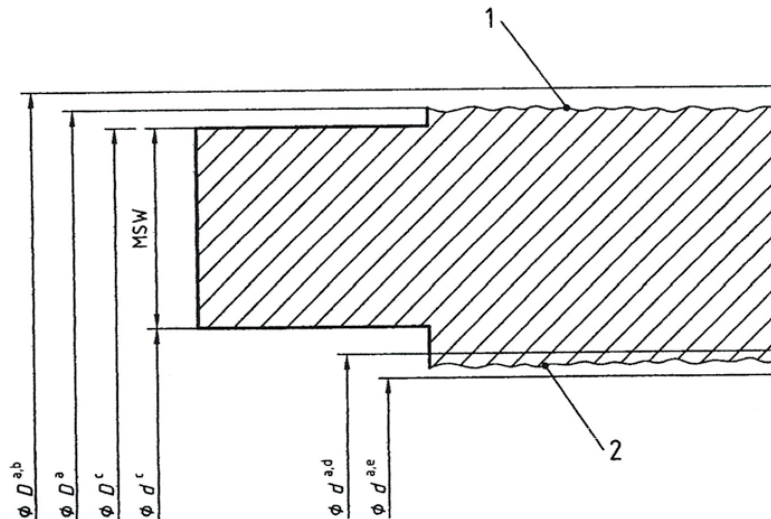

Key

- 1 outside roughness
- 2 inside porosity
- D* outside diameter
- d* inside diameter
- a As-cast.
- b + tolerance.
- c Machined.
- d + porosity.
- e - tolerance.

Figure 1 — Horizontal centrifugally cast tube

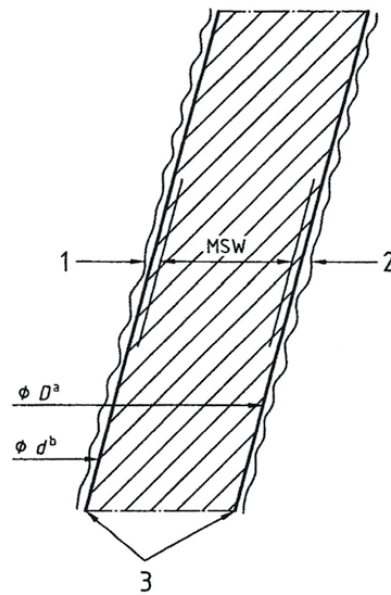

Key

- 1 inside porosity
- 2 outside roughness
- 3 unmachined surfaces with MSW and additions resulting from tolerances on diameters
- a Machined + tolerance.
- b Machined – tolerance.

Figure 2 — Vertical centrifugally cast tube

4 Materials

Materials shall be specified by the purchaser.

5 Supply

The product shall comply with the requirements of ISO 4990.

6 Mechanical tests

6.1 Test pieces for mechanical tests shall be taken either from the centrifugally cast product or from separately cast samples from the same melt as the casting and heat treated under the same conditions as the casting they represent. The tensile test shall be carried out in accordance with ISO 6892-1.

Separately cast samples are acceptable only if agreed between purchaser and manufacturer.

6.2 Upon agreement, the tensile test at room temperature may be substituted by an elevated temperature tensile test, a stress to rupture test or a creep test, (see [12.3](#)). The elevated temperature tensile test shall be carried out in accordance with ISO 6892-2.

7 Surface finish requirements

The surface finish shall be agreed between purchaser and manufacturer.

8 Minimum sound wall (MSW) thickness and soundness

8.1 The purchaser may specify an MSW which may be measured in accordance with either [8.1.1](#) or [8.1.2](#), the method and criteria to be agreed between the purchaser and manufacturer at the time of the enquiry and order.

NOTE In the case of cast products supplied with an as-cast internal surface and having a specified MSW thickness, in order to compensate for unsoundness which can be associated with the cast internal surface, it is necessary to add an internal unsoundness allowance. The allowance that will be necessary in any specific cast will vary according to the total as-cast thickness of the cast product and the soundness requirements. In addition, an allowance can be required to accommodate any minor imperfections associated with the as-cast external surface.

8.1.1 A length of the cast product (100 mm minimum length) machined on the inside and outside diameter surfaces to produce a product having at least the specified MSW and dimensions in accordance with the customer's drawing.

8.1.2 The machined profile end (weld preparation) of the product.

8.2 The MSW thickness shall be measured at 90° intervals. All measurements shall be within the MSW tolerance.

9 Dimensional and shape tolerances

9.1 General

The purchaser shall state clearly on the order the tolerances to be achieved, otherwise the following tolerances shall be used.

9.2 Length

The minimum length of the tube shall be agreed upon between the purchaser and manufacturer. In the case where two or more tubes are welded together, if the minimum length is not stated in the enquiry or order it shall be not less than 1,3 m.

The tolerance on length shall be governed by the diameter of the product as shown in [Table 1](#).

Table 1 — Tolerance on length

Diameter mm	Tolerance mm
≤ 150	+4 0
> 150	+5 0

9.3 Straightness

The deviation from straightness on the full length of tube shall be agreed upon between the purchaser and manufacturer. If no agreement is made, the deviation from straightness shall be at the discretion of the manufacturer.

The cast product may be mechanically straightened at room temperature.

All straightening shall be carried out prior to surface inspection.

9.4 Outside and inside diameters

9.4.1 The tolerance on the outside diameter of the as-cast product shall be in accordance with [Table 2](#).

Table 2 — Tolerance on outside diameter, D

Diameter of product mm	Tolerance mm
≤ 150	$\begin{matrix} +2 \\ 0 \end{matrix}$
> 150 but ≤ 300	$\begin{matrix} +2,5 \\ 0 \end{matrix}$
> 300 but ≤ 500	$\begin{matrix} +4 \\ 0 \end{matrix}$
> 500 but ≤ 750	$\begin{matrix} +5 \\ 0 \end{matrix}$
> 750 but $\leq 1\ 000$	$\begin{matrix} +6 \\ 0 \end{matrix}$
$> 1\ 000$	$\begin{matrix} +8 \\ 0 \end{matrix}$

9.4.2 The tolerances on the machined surfaces shall be stated on the enquiry and order. If tolerances are not given, the following tolerances shall be used:

- tolerance on outside diameter $\begin{matrix} +1,5\text{ mm} \\ 0\text{ mm} \end{matrix}$
- tolerance on inside diameter $\begin{matrix} 0\text{ mm} \\ -1,5\text{ mm} \end{matrix}$

9.4.3 The tolerance on inside diameter, d , of the as-cast product shall be dependent upon the wall thickness of the product as shown in [Table 3](#). For products with an inside diameter greater than 900 mm and a wall thickness greater than 100 mm, the tolerance shall be by agreement between purchaser and manufacturer.

Table 3 — Tolerance on inside diameter, d

d mm	Wall thickness mm	Tolerance mm
≤ 30	—	$\begin{matrix} 0 \\ -3 \end{matrix}$
> 30 but ≤ 300	≤ 25	$\begin{matrix} 0 \\ -3 \end{matrix}$
	> 25 but ≤ 50	$\begin{matrix} 0 \\ -4 \end{matrix}$
	> 50 but ≤ 100	$\begin{matrix} 0 \\ -5 \end{matrix}$
> 300 but ≤ 900	≤ 50	$\begin{matrix} 0 \\ -4 \end{matrix}$
	> 50 but ≤ 80	$\begin{matrix} 0 \\ -5 \end{matrix}$
	> 80 but ≤ 100	$\begin{matrix} 0 \\ -6 \end{matrix}$

10 Inspection procedures and standards of acceptance

10.1 As-cast outside diameter surfaces shall be visually examined.

10.1.1 Indications whose depth violates the minimum sound wall thickness are unacceptable.

10.1.2 Cracks are unacceptable.

10.1.3 Grinding and dye penetrant examination, in accordance with ISO 4987, may be used to verify the type, presence, and depth of the indications.

10.2 Unless otherwise stated on the enquiry and order, the dye penetrant inspection of machined end weld bevels shall have a minimum acceptance level of severity level 01 in accordance with ISO 4987. In the event of failure to meet the above requirement, the manufacturer may reduce the length of the tube.

The tube shall then be re-inspected to the above acceptance level.

10.3 Unless otherwise stated on the enquiry or order, the dye penetrant inspection of machined internal and external surfaces shall have a minimum acceptance level of severity level 4 in accordance with ISO 4987.

When dye penetrant inspection of the bore surface is required, the method and areas to be examined shall be agreed upon by the manufacturer and purchaser.

11 Production welding

Finishing welding shall not be carried out unless agreed upon by purchaser and manufacturer.

12 Supplementary requirements

12.1 General

These may be specified by the purchaser and agreed at the time of the enquiry and order.

12.2 Pressure test

This shall be carried out in accordance with ISO 4990.

12.3 Elevated temperature test

12.3.1 Tensile test at elevated temperature shall be carried out in accordance with ISO 6892-2.

12.3.2 The test conditions for stress to rupture tests and creep tests shall be agreed upon by the purchaser and manufacturer.

12.4 Acid etch ring test

A ring may be taken for macro etching from the end of the product to ascertain the proportion of columnar and equiaxed structure.

The test conditions shall be agreed upon by purchaser and manufacturer.

12.5 Magnetic particle test

This shall be carried out on magnetic alloys only, and in accordance with ISO 4986.

12.6 Ferrite determination

This shall be carried out on austenitic and austenitic ferritic steels and shall be in accordance with ISO 13520.

12.7 Corrosion testing

12.7.1 Intergranular corrosion shall be tested for in accordance with ISO 3651-1 and ISO 3651-2.

12.7.2 Pitting corrosion testing shall be to a method agreed upon by the purchaser and the manufacturer.

12.7.3 Crevice corrosion testing shall be to a method agreed upon by the purchaser and the manufacturer.

12.8 Eddy current testing

Test conditions, method, and criteria shall be agreed upon by the purchaser and the manufacturer.

12.9 Radiography

This shall be carried out in accordance with ISO 4993.

12.10 Ultrasonic testing

Ultrasonic testing shall be carried out in accordance with ISO 4992-1 or ISO 4992-2.

British Standards Institution (BSI)

BSI is the national body responsible for preparing British Standards and other standards-related publications, information and services.

BSI is incorporated by Royal Charter. British Standards and other standardization products are published by BSI Standards Limited.

About us

We bring together business, industry, government, consumers, innovators and others to shape their combined experience and expertise into standards-based solutions.

The knowledge embodied in our standards has been carefully assembled in a dependable format and refined through our open consultation process. Organizations of all sizes and across all sectors choose standards to help them achieve their goals.

Information on standards

We can provide you with the knowledge that your organization needs to succeed. Find out more about British Standards by visiting our website at bsigroup.com/standards or contacting our Customer Services team or Knowledge Centre.

Buying standards

You can buy and download PDF versions of BSI publications, including British and adopted European and international standards, through our website at bsigroup.com/shop, where hard copies can also be purchased.

If you need international and foreign standards from other Standards Development Organizations, hard copies can be ordered from our Customer Services team.

Subscriptions

Our range of subscription services are designed to make using standards easier for you. For further information on our subscription products go to bsigroup.com/subscriptions.

With **British Standards Online (BSOL)** you'll have instant access to over 55,000 British and adopted European and international standards from your desktop. It's available 24/7 and is refreshed daily so you'll always be up to date.

You can keep in touch with standards developments and receive substantial discounts on the purchase price of standards, both in single copy and subscription format, by becoming a **BSI Subscribing Member**.

PLUS is an updating service exclusive to BSI Subscribing Members. You will automatically receive the latest hard copy of your standards when they're revised or replaced.

To find out more about becoming a BSI Subscribing Member and the benefits of membership, please visit bsigroup.com/shop.

With a **Multi-User Network Licence (MUNL)** you are able to host standards publications on your intranet. Licences can cover as few or as many users as you wish. With updates supplied as soon as they're available, you can be sure your documentation is current. For further information, email bsmusales@bsigroup.com.

Revisions

Our British Standards and other publications are updated by amendment or revision.

We continually improve the quality of our products and services to benefit your business. If you find an inaccuracy or ambiguity within a British Standard or other BSI publication please inform the Knowledge Centre.

Copyright

All the data, software and documentation set out in all British Standards and other BSI publications are the property of and copyrighted by BSI, or some person or entity that owns copyright in the information used (such as the international standardization bodies) and has formally licensed such information to BSI for commercial publication and use. Except as permitted under the Copyright, Designs and Patents Act 1988 no extract may be reproduced, stored in a retrieval system or transmitted in any form or by any means – electronic, photocopying, recording or otherwise – without prior written permission from BSI. Details and advice can be obtained from the Copyright & Licensing Department.

Useful Contacts:

Customer Services

Tel: +44 845 086 9001

Email (orders): orders@bsigroup.com

Email (enquiries): cservices@bsigroup.com

Subscriptions

Tel: +44 845 086 9001

Email: subscriptions@bsigroup.com

Knowledge Centre

Tel: +44 20 8996 7004

Email: knowledgecentre@bsigroup.com

Copyright & Licensing

Tel: +44 20 8996 7070

Email: copyright@bsigroup.com

BSI Group Headquarters

389 Chiswick High Road London W4 4AL UK



...making excellence a habit.™