



**National foreword**

This British Standard is the UK implementation of ISO 13472-2:2010.

The UK participation in its preparation was entrusted to Technical Committee EH/1/2, Transport noise.

A list of organizations represented on this committee can be obtained on request to its secretary.

This publication does not purport to include all the necessary provisions of a contract. Users are responsible for its correct application.

© BSI 2010

ISBN 978 0 580 58671 2

ICS 17.140.30; 93.080.20

**Compliance with a British Standard cannot confer immunity from legal obligations.**

This British Standard was published under the authority of the Standards Policy and Strategy Committee on 30 November 2010.

**Amendments issued since publication**

Date	Text affected
------	---------------

---

# INTERNATIONAL STANDARD

**ISO**  
**13472-2**

First edition  
2010-05-15

---

---

## **Acoustics — Measurement of sound absorption properties of road surfaces *in situ* —**

### **Part 2: Spot method for reflective surfaces**

*Acoustique — Mesurage in situ des propriétés d'absorption acoustique  
des revêtements de chaussées —*

*Partie 2: Méthode ponctuelle pour les surfaces réfléchissantes*



Reference number  
ISO 13472-2:2010(E)

© ISO 2010

**PDF disclaimer**

This PDF file may contain embedded typefaces. In accordance with Adobe's licensing policy, this file may be printed or viewed but shall not be edited unless the typefaces which are embedded are licensed to and installed on the computer performing the editing. In downloading this file, parties accept therein the responsibility of not infringing Adobe's licensing policy. The ISO Central Secretariat accepts no liability in this area.

Adobe is a trademark of Adobe Systems Incorporated.

Details of the software products used to create this PDF file can be found in the General Info relative to the file; the PDF-creation parameters were optimized for printing. Every care has been taken to ensure that the file is suitable for use by ISO member bodies. In the unlikely event that a problem relating to it is found, please inform the Central Secretariat at the address given below.



**COPYRIGHT PROTECTED DOCUMENT**

© ISO 2010

All rights reserved. Unless otherwise specified, no part of this publication may be reproduced or utilized in any form or by any means, electronic or mechanical, including photocopying and microfilm, without permission in writing from either ISO at the address below or ISO's member body in the country of the requester.

ISO copyright office  
Case postale 56 • CH-1211 Geneva 20  
Tel. + 41 22 749 01 11  
Fax + 41 22 749 09 47  
E-mail [copyright@iso.org](mailto:copyright@iso.org)  
Web [www.iso.org](http://www.iso.org)

Published in Switzerland

# Contents

Page

Foreword .....	iv
Introduction.....	v
<b>1</b> <b>Scope</b> .....	<b>1</b>
<b>2</b> <b>Normative references</b> .....	<b>1</b>
<b>3</b> <b>Terms and definitions</b> .....	<b>2</b>
<b>4</b> <b>Principle</b> .....	<b>2</b>
<b>5</b> <b>Test equipment</b> .....	<b>4</b>
<b>5.1</b> <b>Components of the test system</b> .....	<b>4</b>
<b>5.2</b> <b>Sound source</b> .....	<b>4</b>
<b>5.3</b> <b>Test signal</b> .....	<b>4</b>
<b>5.4</b> <b>Impedance tube</b> .....	<b>4</b>
<b>5.4.1</b> <b>Tube diameter</b> .....	<b>4</b>
<b>5.4.2</b> <b>Tube length and microphone positions</b> .....	<b>5</b>
<b>5.5</b> <b>Microphones</b> .....	<b>6</b>
<b>5.6</b> <b><i>In-situ</i> test fixture between impedance tube and test surface</b> .....	<b>6</b>
<b>5.7</b> <b>Signal-processing system</b> .....	<b>6</b>
<b>5.8</b> <b>Thermometer and pressure measurement</b> .....	<b>6</b>
<b>6</b> <b>Measurement and analysis procedure</b> .....	<b>6</b>
<b>6.1</b> <b>Stabilizing the system</b> .....	<b>6</b>
<b>6.2</b> <b>Calibration of the system</b> .....	<b>7</b>
<b>6.3</b> <b>Reference measurement</b> .....	<b>7</b>
<b>6.4</b> <b>Background noise measurement</b> .....	<b>7</b>
<b>6.5</b> <b>Measurement of a road surface</b> .....	<b>7</b>
<b>6.6</b> <b>Data analysis</b> .....	<b>8</b>
<b>7</b> <b>Positioning of the equipment</b> .....	<b>8</b>
<b>7.1</b> <b>Location of the measurement positions</b> .....	<b>8</b>
<b>7.1.1</b> <b>Test surfaces such as those meeting ISO 10844 requirements</b> .....	<b>8</b>
<b>7.1.2</b> <b>Regular roads</b> .....	<b>8</b>
<b>7.2</b> <b>Condition of the road surface</b> .....	<b>8</b>
<b>7.3</b> <b>Temperature</b> .....	<b>8</b>
<b>8</b> <b>Measurement and analysis procedure</b> .....	<b>8</b>
<b>9</b> <b>Measurement uncertainty</b> .....	<b>9</b>
<b>10</b> <b>Test report</b> .....	<b>11</b>
<b>Annex A</b> (normative) <b>Correction on base of reference measurement</b> .....	<b>12</b>
<b>Annex B</b> (informative) <b>Measurement uncertainty</b> .....	<b>13</b>
<b>B.1</b> <b>General</b> .....	<b>13</b>
<b>B.2</b> <b>Expression for the calculation of the absorption coefficient</b> .....	<b>13</b>
<b>B.3</b> <b>Sources of uncertainty</b> .....	<b>14</b>
<b>B.4</b> <b>Expanded uncertainty of measurement</b> .....	<b>15</b>
<b>Annex C</b> (informative) <b>Sketch of <i>in-situ</i> test fixture</b> .....	<b>16</b>
<b>Annex D</b> (informative) <b>Example of a test report</b> .....	<b>18</b>
<b>Bibliography</b> .....	<b>20</b>

## Foreword

ISO (the International Organization for Standardization) is a worldwide federation of national standards bodies (ISO member bodies). The work of preparing International Standards is normally carried out through ISO technical committees. Each member body interested in a subject for which a technical committee has been established has the right to be represented on that committee. International organizations, governmental and non-governmental, in liaison with ISO, also take part in the work. ISO collaborates closely with the International Electrotechnical Commission (IEC) on all matters of electrotechnical standardization.

International Standards are drafted in accordance with the rules given in the ISO/IEC Directives, Part 2.

The main task of technical committees is to prepare International Standards. Draft International Standards adopted by the technical committees are circulated to the member bodies for voting. Publication as an International Standard requires approval by at least 75 % of the member bodies casting a vote.

Attention is drawn to the possibility that some of the elements of this document may be the subject of patent rights. ISO shall not be held responsible for identifying any or all such patent rights.

ISO 13472-2 was prepared by Technical Committee ISO/TC 43, *Acoustics*, Subcommittee SC 1, *Noise*.

ISO 13472 consists of the following parts, under the general title *Acoustics — Measurement of sound absorption properties of road surfaces in situ*:

- *Part 1: Extended surface method*
- *Part 2: Spot method for reflective surfaces*

## Introduction

This part of ISO 13472 specifies a test method for measuring *in situ* the sound absorption coefficient of road surfaces as a function of frequency under normal incidence.

This method enables evaluation of the sound absorption characteristics of a road surface without damaging the surface. It is intended to be used to qualify the absorption characteristics of road surfaces used for vehicle and tyre testing. It may also be used during road construction, road maintenance, and other traffic noise studies. However, the field of application is limited to low absorption surfaces.

The method specified in this part of ISO 13472 is based on propagation of the test signal from the source to the road surface and back to the receiver through an impedance tube. The tube covers an area of approximately 0,008 m<sup>2</sup> and a frequency range, in one-third-octave bands, from 250 Hz to 1 600 Hz. It uses the test procedure and signal processing specified in ISO 10534-2, but because of the defined frequency range of application, the dimensions of the system are not adjustable, but fixed.

This method is primarily intended for smooth low absorption surfaces, such as those in accordance with ISO 10844. The method is not reliable if the measured sound absorption coefficient exceeds 0,15. Surfaces with values above 0,10 are not considered to be reflective.

This method is complementary to the extended surface method (ISO 13472-1<sup>[5]</sup>) that covers an area of approximately 3 m<sup>2</sup> and a frequency range, in one-third-octave bands, from 250 Hz to 4 000 Hz.

Both methods should give similar results in the frequency range from 315 Hz to 1 600 Hz, but their fields of application and therefore their accuracy differ strongly. The method described in ISO 13472-1<sup>[5]</sup> has limited accuracy at small sound absorption values and is therefore unsuitable for checking compliance of surfaces with the requirements of such documents as ISO 10844, while the method specified here fails at higher sound absorption values.

Within their ranges, the methods are also applicable to acoustic materials other than road surfaces.

The measurement results of this method are comparable to the results of the impedance tube method, performed on bore cores taken from the surface in accordance with documents such as ISO 10534-1<sup>[4]</sup>, ISO 10534-2 and ASTM E1050<sup>[7]</sup>.

The measurement results obtained with this method are in general not comparable to the results of the reverberation room method (ISO 354<sup>[1]</sup>), because the method described in this part of ISO 13472 uses a plane progressive wave at perpendicular incidence, while the reverberation room method uses a diffuse sound field.





# Acoustics — Measurement of sound absorption properties of road surfaces *in situ* —

## Part 2: Spot method for reflective surfaces

### 1 Scope

This part of ISO 13472 specifies a test method for measuring *in situ* the sound absorption coefficient of road surfaces for the one-third-octave-band frequencies ranging from 250 Hz to 1 600 Hz under normal incidence conditions. For special purposes, the frequency range can be changed by modifying the dimensions of the system.

The test method is intended for:

- a) determination of the sound absorption coefficient of semi-dense to dense road surfaces (and, if of interest, also the complex acoustical impedance);
- b) determination of the sound absorption properties of test tracks in accordance with standards such as ISO 10844 and test surfaces defined in national and international type approval regulations for road vehicles and vehicle tyres;
- c) verification of the compliance of the sound absorption coefficient of a road surface with design specifications or other requirements.

### 2 Normative references

The following referenced documents are indispensable for the application of this document. For dated references, only the edition cited applies. For undated references, the latest edition of the referenced document (including any amendments) applies.

ISO 10534-2:1998, *Acoustics — Determination of sound absorption coefficient and impedance in impedance tubes — Part 2: Transfer-function method*

ISO 10844, *Acoustics — Specification of test tracks for measuring noise emitted by road vehicles and their tyres*

ISO/IEC Guide 98-3:2008, *Uncertainty of measurement — Part 3: Guide to the expression of uncertainty in measurement (GUM:1995)*

IEC 61260, *Electroacoustics — Octave-band and fractional-octave-band filters*

### 3 Terms and definitions

For the purposes of this document, the following definitions apply.

#### 3.1 frequency range

frequency interval in which measurements are valid specified in one-third-octave bands in accordance with IEC 61260

NOTE The frequency range is specified in one-third-octave bands. This means that its lower limit is the lower limit of the lowest one-third-octave band specified and its upper limit is the upper limit of the highest one-third-octave band specified. The frequency range specified in one-third-octave bands of 250 Hz to 1 600 Hz centre frequency implies a frequency range specified in narrow bands of 220 Hz to 1 800 Hz.

#### 3.2 sound absorption coefficient at normal incidence

$\alpha$

ratio of sound power entering the surface of the test object (without return) to the incident sound power for a plane wave at normal incidence

[ISO 10534-2:1998, 2.1]

#### 3.3 sound pressure reflection factor at normal incidence

$r$

complex ratio of the pressure of the reflected wave to the pressure of the incident wave at the surface of the test object for a plane wave at normal incidence

#### 3.4 plane of reference for the road surface

hypothetical plane defined by the underside of the sealing device at which the sound pressure reflection factor is calculated

#### 3.5 signal-to-noise ratio level

difference, in decibels, between the level of the useful signal and the level of the background noise

#### 3.6 normal surface impedance

$Z$

ratio of the complex sound pressure to the normal component of the complex sound particle velocity at an individual frequency in the reference plane

NOTE 1 Adapted from ISO 10534-2:1998, 2.4.

NOTE 2 Although not used in specifications of road surfaces, calculating propagation over such a surface requires a complex acoustic impedance.

### 4 Principle

The two microphone impedance tube method (see ISO 10534-2 or ASTM E1050<sup>[7]</sup>) is adapted to a portable apparatus that enables the normal incidence sound absorption coefficient of plane surfaces to be rapidly measured over a broad frequency range without distortion of the surface. The procedure enables a single skilled operator to perform such measurements. There is no need for a calibration for microphones as required in typical acoustic measurements, but it does require a specific verification of the two microphone apparatus for amplitude and phase relationship between microphones at the time of the measurement and a determination of the internal energy loss of the system based on measurements on a totally reflecting plane.

The apparatus is a standard impedance tube utilizing the two microphone arrangement. A sound signal from a loudspeaker located at one end propagates through the tube. The open end of the tube is placed on the surface to be measured. The complex acoustic transfer function of the two microphone signals is determined and used to compute the normal incidence sound absorption coefficient and related quantities.

The absorption coefficient covers the one-third-octave-band frequency range from 250 Hz to 1 600 Hz.

Figure 1 illustrates the system set-up.

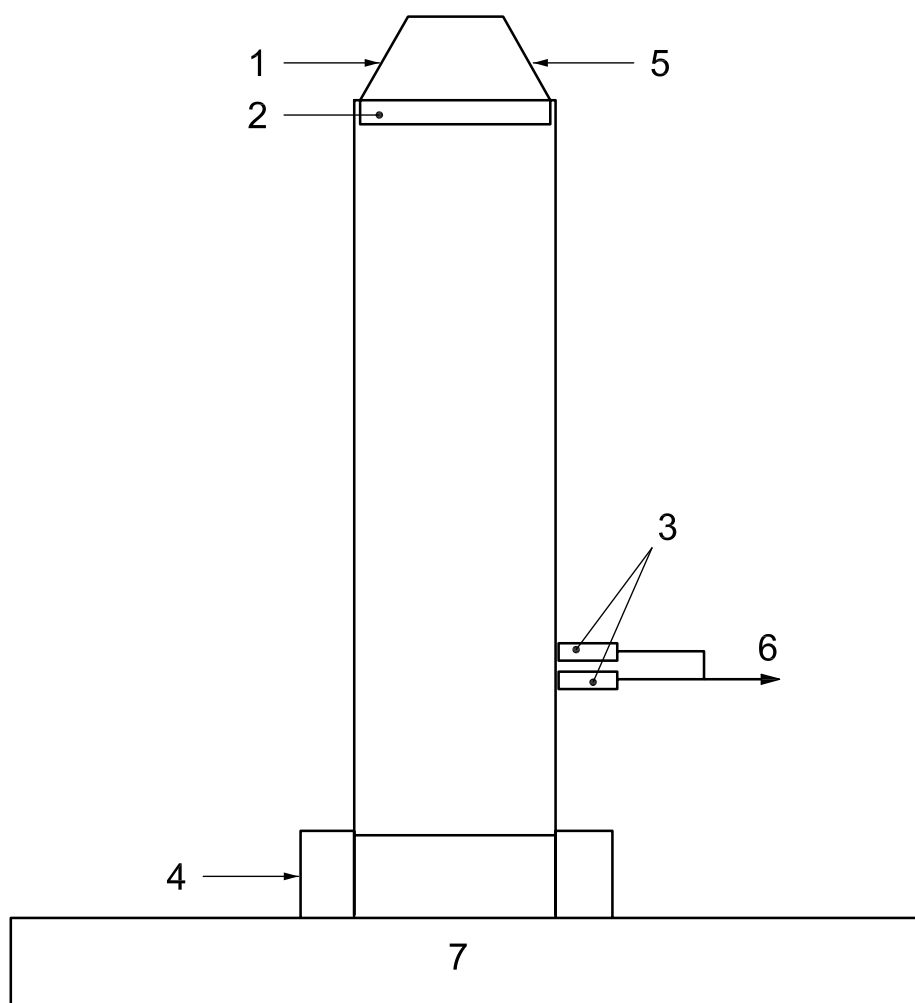

**Key**

- 1 loudspeaker
- 2 vibration isolation
- 3 microphones
- 4 *in-situ* test fixture
- 5 sound source and amplifier
- 6 frequency analyser
- 7 surface under test

**Figure 1 — Configuration of the measuring device and related equipment**

The signal processing is described in ISO 10534-2 and ASTM E1050<sup>[7]</sup> and consists basically of the measurement of the complex transfer function between the two microphones in the presence of the sample under test. This is then processed to obtain the complex pressure reflection factor from which the acoustic absorption can be calculated. The procedure described in ISO 10534-2 and ASTM E1050<sup>[7]</sup> includes the calibration of amplitude and phase properties of the two microphones.

In this method, the test sample holder specified in ISO 10534-2 is replaced by an *in-situ* test fixture that enables an airtight connection between the inside of the test tube and the surface of the road under test. The test tube and the fixture can be either integrated into a single piece or connected by some kind of fixing device and an airtight seal such as a rubber O-ring.

On the underside of the *in-situ* test fixture, a ring of deformable material forms an airtight seal with the surface texture of the road surface on one hand and with the fixture on the other. Sealing is improved with a small groove made in the fixture (see Figures C.1 and C.2).

The sound absorption coefficient is determined in accordance with the procedure specified in ISO 10534-2.

## 5 Test equipment

### 5.1 Components of the test system

The test equipment comprises a signal generator, a sound source, a tube, two microphones mounted flush with the inside wall of the tube at the specified positions, an *in-situ* test fixture device to maintain an airtight fit to the surface, and a signal-processing unit capable of doing complex Fourier transforms in two channels simultaneously.

Any measurement system that provides the characteristics and meets the criteria specified in ISO 10534-2 is acceptable.

### 5.2 Sound source

The sound source shall meet the requirements defined in ISO 10534-2. It:

- a) is sealed to and vibration isolated from the tube to minimize structure-borne sound excitation of the tube;
- b) has a uniform power response over the frequency range of interest.

### 5.3 Test signal

The test signal shall be broad band with a uniform spectral density over the frequency range of interest.

A signal generator capable of producing a compatible test signal is often incorporated in a frequency analysis system. When employing alternative signals, it is recommended that the time blocks in the frequency analysis be synchronized with repetitions in the test signal pattern.

### 5.4 Impedance tube

#### 5.4.1 Tube diameter

The diameter of the tube shall be  $(100 \pm 1)$  mm. The tube shall have a circular cross-section, be straight with a uniform cross-section (variations in diameter no greater than 0,2 %) and with smooth, non-porous walls, without holes or slits and rigid so as to prevent unwanted loss of sound energy.

NOTE 1 Not meeting the diameter requirement affects the frequency range. The upper frequency at a given diameter,  $f_u$ , is given by the equation:

$$f_u = 0,58 \frac{c_0}{d}$$

where

$c_0$  is the speed of sound, in metres per second;

$d$  is the diameter, in metres, of the tube.

NOTE 2 Loss of energy due to vibrations of the walls is generally prevented by using a metal tube with a thickness of at least 5 % of the tube diameter.

The tube shall have a small ventilation hole in the vicinity of the loudspeaker so as to prevent build-up of static pressure inside the tube.

#### 5.4.2 Tube length and microphone positions

The length shall be sufficient to make a plane wave develop between the source and the position of the microphone. This requirement is met when the microphones are at a distance not less than  $3d$ , where  $d$  is the tube diameter, from the sound source. Non-plane waves from the sample are generally suppressed within one tube diameter. In the case of flat road surfaces and a tube diameter of 100 mm, this is realized by a tube with a minimum length of 480 mm and with the lowest microphone mounted 100 mm from the plane of reference.

Microphones shall be mounted flush with the inner side wall. When a single pair of microphone positions is used, the spacing shall be  $(81 \pm 4)$  mm.

NOTE The minimum and maximum value of the microphones spacing,  $s$ , is defined by the upper and lower frequency of interest as follows.

The maximum spacing is slightly less than half of the shortest wavelength and is given by the inequality:

$$s_{\max} < 0,45 \frac{c_0}{f_{\max}}$$

A maximum frequency of 1 800 Hz implies a maximum spacing of 85 mm.

The minimum spacing is larger than 5 % of the longest wavelength and is given by the inequality:

$$s_{\min} > 0,05 \frac{c_0}{f_{\min}}$$

A minimum frequency of 220 Hz implies a minimum spacing of 77 mm.

Reflective test objects cause at certain frequencies destructive interference at the position of the microphones that jeopardizes the signal-to-noise ratio. The test result can be improved by using different microphone positions and spacing. Several systems allow for three choices of microphone positioning to allow a wider spacing for the lower frequency range and a narrow spacing for the higher frequency range.

The spacing shall be known within  $\pm 0,5$  mm.

## 5.5 Microphones

A pair of nominally identical microphones shall be mounted at the specified positions. The microphone diameter shall be small in comparison with the spacing between the microphone ports. It is recommended that the microphone diameter be less than 20 % of the smallest spacing used. This in general implies the application of "1/4 inch" microphones. For side-wall mounting, microphones of the pressure type are recommended.

The microphone mountings shall give an airtight seal between the microphone housing and wall of the tube.

Take care when mounting the microphones to follow the manufacturer's recommendation that venting holes not be blocked. Blocked venting holes can result in static pressure build-up over the diaphragm that alters the phase response.

## 5.6 *In-situ* test fixture between impedance tube and test surface

Similar to a detachable holder (ISO 10534-2:1998, 4.7), an *in-situ* test fixture shall be fitted in such a way as to avoid air flowing between the end of the tube opposite the sound source and the surface to be measured. Any air leakage through this interface appears as absorption in the measurement results. The *in-situ* test fixture, like the detachable holder, shall conform to the interior shape and dimensions of the main part of the impedance tube. The connecting joint of the *in-situ* test fixture shall be finished carefully and shall exhibit no slit or hole. The use of a sealant, such as an O-ring, is required for sealing it to the main part of the impedance tube. Additionally, a groove shall be cut in the *in-situ* test fixture on the specimen side to accept a bead of sealing material such as water-soluble modelling clay, for sealing the fixture to the road.

Practically, the *in-situ* test fixture should have a larger outer diameter than the main part of the tube. The additional diameter is not used in the measurement, but this additional portion aids in stability when the system is mounted upright (see Annex C).

The sealing material shall fill irregularities due to surface texture but shall not penetrate into the surface and shall not spread out on the surface.

## 5.7 Signal-processing system

The signal-processing unit consists of a two-channel signal analyser capable of determining the narrowband complex transfer function between the two microphones. The device shall meet the requirements stated in ISO 10534-2.

NOTE In most cases, this is a multi-channel fast Fourier transform (FFT) signal analyser, but other solutions are possible. Modern FFT analysers use special signals such as maximum length sequence (MLS) or swept (logarithmic) sinus for better performance.

## 5.8 Thermometer and pressure measurement

The temperature shall be measured with a system readable to  $\pm 1$  °C. The atmospheric pressure shall be measured with a system readable to  $\pm 0,5$  kPa.

# 6 Measurement and analysis procedure

## 6.1 Stabilizing the system

Since the measurement principle relies strongly on accurate phase and amplitude measurements, the system shall be thermally stable, including the electronic parts, the loudspeaker coil, and the tube. Therefore, before starting measurements, the system shall be switched on and operating for at least 15 min. Furthermore, the system shall not be exposed to direct sunlight or other strong thermal sources.

## 6.2 Calibration of the system

The phase and amplitude relationship between the microphones shall be determined before each measurement series and after each hour of measurements for each microphone position in accordance with the procedure specified in ISO 10534-2:1998, 7.5.

Knowledge of the phase and amplitude response relationship between the microphones is necessary to enable correction for it in the determination of the complex transfer function between the two microphone positions.

All parts of the measuring system shall be checked at least once a year for proper functioning in accordance with the manufacturer's specifications.

## 6.3 Reference measurement

A reference measurement on a totally reflective specimen, e.g. a steel plate of 10 mm thickness, shall be conducted. Calculate the one-third-octave-band absorption coefficients of the reflective specimen by averaging the narrowband absorption data. The reference level in each one-third-octave band shall be less than 0,03.

The reference measurement shall take place at the same location and directly before or after the actual measurement series. The results of the reference measurement shall be used to correct the measurement results for internal energy loss in accordance with the procedure specified in Annex A.

## 6.4 Background noise measurement

A measurement shall be made with the sound signal switched off. Consecutive measurements shall be checked against this level for a minimum signal-to-noise level of 10 dB in each one-third-octave band.

To prevent possible interference by non-stationary background noise, measurements shall be performed at least at 25 m from passing heavy vehicles or motorcycles. Any measurement that comprises potential disturbance by background noise shall be omitted.

## 6.5 Measurement of a road surface

Apply a small bead of sealant into the groove made in the *in-situ* test fixture. The size of bead depends on the surface texture. Smooth surfaces allow a small bead extending only a few millimetres above the underside of the fixture; large texture depths require a thicker bead. One has used the right amount when, after pressing the fixture on the road, little material is pressed out from under the fixture. If nearly no material is pressed out, remove the fixture and check for a complete circular impressing of the sealing material on the road. If that is not the case increase the amount of sealant and redo the mounting of the fixture. Remove any pressed-out sealing material.

Carefully mount the tube, without moving the fixture. Turn on the source and check for possible air leakage.

NOTE This can be done for instance by a stethoscope with an open tube, scanning the perimeter of the coupler.

Perform the measurement, and check the signal-to-noise ratio. If it is too low, increase the level of the sound source, remove the source of background noise or wait for a quiet moment.

Remove the tube and fixture and check if the sealing material has been in tight contact with the road surface in a closed circle. In case of doubt, repeat the sealing procedure and the measurement. After having completed the measurements, carefully remove any sealing material that has remained on the surface.

Repeat the measurements at the specified positions.

## 6.6 Data analysis

Apply the procedure specified in ISO 10534-2 to calculate the narrowband absorption coefficient from the measured transfer function. If two pairs of microphone positions are used, repeat the procedure for the other pair of microphone positions. Construct the resulting narrowband absorption coefficient by using the values found for each microphone pair in the optimal frequency range for that microphone pair (see 5.4.2).

The road surface sound absorption coefficient in one-third-octave bands is computed by linear averaging the narrow-band absorption data over the one-third-octave-band frequency ranges in the required frequency range, allowing negative values that might result from the FFT processing. Then correct for the reference level with the procedure specified in Annex A. Negative values in the resulting one-third-octave bands shall be replaced by zero-values.

## 7 Positioning of the equipment

### 7.1 Location of the measurement positions

#### 7.1.1 Test surfaces such as those meeting ISO 10844 requirements

Refer to ISO 10844 for the positions.

#### 7.1.2 Regular roads

The measurement positions shall be regularly spaced over the surface area of interest, with an emphasis on the wheel tracks. The spacing can be defined as required by the specific objective. As a guideline, a measurement each 10 m gives results with relevance to observation positions at 7,5 m from the centre of the lane.

### 7.2 Condition of the road surface

The road surface shall be smooth, flat and free of debris. Measurements shall not be carried out unless the road surface is dry.

### 7.3 Temperature

The ambient air temperature shall be between 5 °C and 30 °C during the measurement. The road surface temperature shall be between 5 °C and 45 °C during the measurement.

Measurements shall not take place in direct solar radiation or in the vicinity of strong heat sources.

For areas where the above requirements are hard to obtain, testing at night is suggested.

## 8 Measurement and analysis procedure

The measurement shall be carried out as follows:

- a) check the road surface and meteorological conditions to ensure compliance with the specifications in Clause 7 — if these conditions are not met, the measurement cannot be carried out;
- b) switch on the system for at least 15 min;
- c) perform the microphone calibration procedure (6.2);
- d) perform the reference measurement with a totally reflective surface (6.3);



- e) place the measuring equipment on site as specified in 7.1, apply the sealant carefully in order to suppress measuring errors due to leakage, and check the correctness of the sealing visually or audibly;
- f) perform the measurement: if online monitoring of the result is possible, proceed with averaging until a stable result is obtained — if this is not possible, averaging over 50 sweeps or bursts is recommended;
- g) refer to ISO 10534-2 for procedures for measurement and calculation of both the sound pressure reflection factor and the sound absorption coefficient from the transfer function and tube geometry;
- h) then compute the road surface sound absorption coefficient in one-third-octave bands (6.6);
- i) repeat the measurements on at least four required positions and calculate the mean value and the standard deviation in each one-third-octave band;
- j) compile the test report (see Clause 10 and Annex D).

## 9 Measurement uncertainty

**9.1** The measurement procedure specified in this part of ISO 13472 is affected by several influencing factors that lead to variation in the results observed for the same subject. The source and nature of these perturbations are not completely known. The measurement uncertainty is determined in accordance with ISO/IEC Guide 98-3.

In accordance with ISO/IEC Guide 98-3, each significant source of error shall be identified and corrected for. The following sources of error have been identified and shall be processed in accordance with the procedure described in ISO/IEC Guide 98-3. See Annex B for an example of a quantitative analysis.

**9.2** The error related to deducing the sound absorption coefficient from the measured transfer function between the two microphones in the impedance tube in accordance with the procedure given in ISO 10534-2. This source includes errors due to uncertainty in the distance between the acoustic centres of the microphones, statistical error in the determination of the transfer function with stochastic signals and other sources directly related to the ISO 10534-2 procedure. Also the effect of deviating and varying meteorological conditions during the testing on the determination of the absorption coefficient has to be taken into account.

**9.3** The error due to internal losses of acoustic energy in the tube. Though not of relevance if measuring absorbing cores, it can cause significant errors when measuring nearly reflecting road surfaces. This error is partly corrected for by the mandatory reference measurement on a reflective plate.

**9.4** Carefully check for the effect of possible leakage in the tube/road interface, which can cause effects of up to 0,2 and which manifests itself mainly in the lower frequency ranges. Since this effect is in positive direction only, it does not jeopardize determining maximum requirements as stated in ISO 10844, but can affect the assessment of semi-dense surfaces significantly.

**9.5** The statistical representativity of the chosen points. This error is not an error in the determination of the absorption coefficient at a certain position; it presents a source of error in the determination of the acoustic absorption of a road section. This error can be minimized by repeating the number of measurements until a acceptable spread in the results is obtained.

**9.6** The general expression for the calculation of the corrected absorption coefficient,  $\alpha(f)$ , is:

$$\alpha(f) = \alpha_m(f) - \alpha_{\text{system}}(f) + \delta_1 + \delta_2 + \delta_3 + \delta_4 \quad (1)$$

where

$\alpha_m(f)$  is the measured absorption;

$\alpha_{\text{system}}(f)$  is the internal damping measured with the reference test object;

- $\delta_1$  is an input quantity to allow for any uncertainty in the ISO 10534-2 procedure;
- $\delta_2$  is an input quantity to allow for any uncertainty in the ISO 10534-2 procedure due to varying external conditions;
- $\delta_3$  is an input quantity to allow for any uncertainty in the reference procedure;
- $\delta_4$  is an input quantity to allow for any uncertainty due to unintended pressure loss.

The value of these input quantities shall be evaluated by the procedure given in ISO/IEC Guide 98-3. That can be based on existing statistical data, analysis of tolerances stated in this part of ISO 13472 and engineering judgement. The information needed from which to derive the overall uncertainty is given in Table 1.

**Table 1 — Uncertainty budget for the determination of the absorption coefficient**

Quantity	Estimate	Probability distribution	Standard uncertainty $u_i$	Sensitivity coefficient $c_i$	Uncertainty contribution $c_i u_i$
$\delta_1$	0	normal		1	
$\delta_2$	0	normal		1	
$\delta_3$	0	normal		1	
$\delta_4$	0	normal		1	
Combined standard uncertainty $[u(\alpha)]$					

The combined standard uncertainty is calculated using Equation (2):

$$u(\alpha) = \sqrt{\sum_{i=1}^4 (c_i u_i)^2} \tag{2}$$

The expanded uncertainty,  $U$ , is determined by multiplying the combined standard uncertainty,  $u(\alpha)$ , by the appropriate coverage factor for the chosen coverage probability as described in ISO/IEC Guide 98-3.

Annex B gives a detailed listing of the standard uncertainties and sensitivity coefficients of each source.

Using these values for a typical test track surface that complies with ISO 10844, the uncertainty budget results in an overall standard uncertainty in the absorption coefficient of 0,015 in each one-third-octave band. This implies the uncertainty values given in Table 2.

**Table 2 — Expanded uncertainty in the absorption coefficient in a one-third-octave band and the probability coverage situation for a typical ISO 10844 test track surface**

Probability coverage	Expanded uncertainty
80 %	0,022
95 %	0,029

## 10 Test report

The test report shall contain at least the following information:

- a) reference to this part of ISO 13472 (ISO 13472-2:2010);
- b) name and address of the testing organization;
- c) date and place of the test;
- d) description of the test site: drawing or pictures showing the road surface under test, measurement set-up;
- e) description of the road surface under test: age, measurement conditions, composition (thickness, material specification, etc.);
- f) road surface conditions with regard to dryness and temperature;
- g) meteorological conditions prevailing during the test (atmospheric pressure, air and road surface temperatures);
- h) equipment used for measurement and analysis, including name, type, serial number and manufacturer;
- i) test result in terms of mean value over the positions and the standard deviation;
- j) signature of the person responsible for the measurements;
- k) expanded uncertainty for a coverage probability of 80 % and of 95 % together with the respective coverage factor.

The test results shall be given in the form of a graph and a table, showing the values of the sound absorption coefficient in one-third-octave frequency bands from 250 Hz to 1 600 Hz. In addition, the test results may also be presented in narrowband spectra between 220 Hz and 1 800 Hz.

Optionally, the sound pressure reflection factor of the surface in narrow frequency bands may be included.

The values of the sound absorption coefficient shall be rounded off to two decimal places.

An example of a test report is given in Annex D.

## Annex A (normative)

### Correction on base of reference measurement

The system determines all loss of energy in the path between microphones and test object as absorption. If surfaces are reflective, the contribution of internal losses due to thermal and viscous energy loss may influence the total result significantly and thus shall be corrected for. This is done by applying the system to a 100 % reflective test object (such as a steel plate) and using the resulting reading as a correction value for the other measurements.

Since the measured values are low (below 0,15) and in a well-built system the internal losses are low (below 0,03), the correction can be done by subtracting the reference data from the measurements to arrive at the corrected absorption,  $\alpha(f)$ :

$$\alpha(f) \approx \alpha_m(f) - \alpha_{\text{system}}(f)$$

where

$\alpha_m(f)$  is the measured absorption;

$\alpha_{\text{system}}(f)$  is the internal damping measured with the reference test object.

Since factors influencing this parasitic absorption vary with external conditions, this reference measurement shall be made directly before or after the measurement series.

## Annex B (informative)

### Measurement uncertainty

#### B.1 General

The uncertainty in the measurement result comprises two sources:

- a) the uncertainty in the procedure of establishing absorption based on the ISO 10534-2 procedure;
- b) the uncertainty due to the application of the ISO 10534-2 procedure under varying external conditions, due to effects on inadequate compensation for internal losses, effects of varying meteorological conditions when operating *in situ* and effects of unintended pressure loss in the interface between road and apparatus.

In accordance with ISO/IEC Guide 98-3, these effects are evaluated on the basis of their contribution to the combined standard uncertainty and then a coverage probability is defined, resulting in a coverage factor,  $k$ , by which the combined standard uncertainty is multiplied, yielding the expanded uncertainty.

#### B.2 Expression for the calculation of the absorption coefficient

The general expression for the determination of the corrected sound absorption coefficient,  $\alpha(f)$ , is:

$$\alpha(f) = \alpha_m(f) - \alpha_{\text{system}}(f) + \delta_1 + \delta_2 + \delta_3 + \delta_4 \quad (\text{B.1})$$

where

- |                             |  |
|-----------------------------|--|
| $\alpha_m(f)$               | is the measured absorption;  |
| $\alpha_{\text{system}}(f)$ | is the internal damping measured with the reference test object;   |
| $\delta_1$                  | is an input quantity to allow for any uncertainty in the ISO 10534-2 procedure;                                |
| $\delta_2$                  | is an input quantity to allow for any uncertainty in ISO 10534-2 procedure due to varying external conditions; |
| $\delta_3$                  | is an input quantity to allow for any uncertainty in the reference procedure;                                  |
| $\delta_4$                  | is an input quantity to allow for any uncertainty due to unintended pressure loss.                             |

In Clause B.3, an example is given of a typical road surface found on test tracks and meeting the requirements of ISO 10844.

### B.3 Sources of uncertainty

**B.3.1**  $\delta_1$ : ISO 10534-2 does not specify an uncertainty of the measurement method but gives an indication that the expected standard uncertainty is about 0,01. This is corroborated by repeated application of the procedure of ISO 10534-2 that results in a standard deviation in one-third-octave-band measurement results of 0,01. Since the procedure is applied to low absorption samples and a correction is made for the energy loss in the tube, by measuring on a 100 % reflective surface, the uncertainty introduced by the procedure is very small and is estimated to be about 0,01 standard uncertainty with a normal distribution.

**B.3.2**  $\delta_2$ : Repeated application of the procedure of ISO 10534-2 outside the laboratory results in a standard deviation in one-third-octave-band measurements of 0,011 which, when taking into account the expected spread due to the ISO 10534-2 procedure, leads to an uncertainty due to varying external conditions of about 0,005 with a normal distribution.

**B.3.3**  $\delta_3$ : The reference measurement procedure is subject to similar uncertainties, but since it is done with the same system, they are of slightly smaller magnitude. Experimental evidence indicates an uncertainty contribution of about 0,008 with a normal distribution.

**B.3.4**  $\delta_4$ : The effect of the sealing procedure on the accuracy in the end result is strongly non-linear. For results below 0,10 in one-third-octave bands, the effect is small (far below 0,01). If results are above 0,2, a clear low frequency increase in absorption was also observed which can be explained by air leakage. A coefficient of 0,15 is estimated to be the maximum reliable result. Up to a measured absorption coefficient of 0,1, the leakage effect is estimated to be about 0,005 with a skewed distribution in the direction of increase of results.

**B.3.5** One of the main sources of uncertainty, namely energy loss in the system, is minimized by the specified reference measurement procedure. Each of the  $\delta$  input quantities is considered to have an estimate of zero, i.e. no correction is applied to the measured sound absorption coefficient. However, each of these quantities is associated with an uncertainty as explained below.

NOTE The input quantities in Equation (B.1) to allow for uncertainties are those thought to be applicable in accordance with the state of knowledge at the time of publication of this part of ISO 13472, but further research could reveal that there are others.

**Table B.1 — Estimated values for contributions to the uncertainty budget if a road surface meets the requirements of ISO 10844**

Quantity	Estimate	Probability distribution	Standard uncertainty $u_i$	Sensitivity coefficient $c_i$	Uncertainty contribution $c_i u_i$
$\delta_1$	0	normal	0,01	1	0,01
$\delta_2$	0	normal	0,005	1	0,005
$\delta_3$	0	normal	0,008	1	0,008
$\delta_4$	0	normal	0,005	1	0,005
Combined standard uncertainty $[u(\alpha)]$					0,015
When lacking specific information, these figures can be used as default values.					

The combined standard uncertainty is calculated by Equation (B.2):

$$u(\alpha) = \sqrt{\sum_{i=1}^4 (c_i u_i)^2} \quad (\text{B.2})$$

#### B.4 Expanded uncertainty of measurement

The expanded uncertainty,  $U$ , is found by multiplying the combined standard uncertainty,  $u(\alpha)$ , by the appropriate coverage factor for the chosen coverage probability as described in ISO/IEC Guide 98-3.

The combined standard uncertainty in the assessment of the absorption coefficient in this example is 0,015. This results in an expanded uncertainty of 0,022 with 80 % coverage probability and 0,029 with 95 % coverage probability.

## Annex C (informative)

### Sketch of *in-situ* test fixture

The *in-situ* test fixture should have a leakage-free connection with the test tube and enable airtight fitting with the road surface by means of a sealing material.

The first requirement is taken care of by carefully machining the connection and application of a sealing device such as a rubber O-ring.

Airtight connection to the test surface is effected by machining a small groove, about 2 mm wide and deep, at about 1 mm to 2 mm from the inner wall of the fixture.

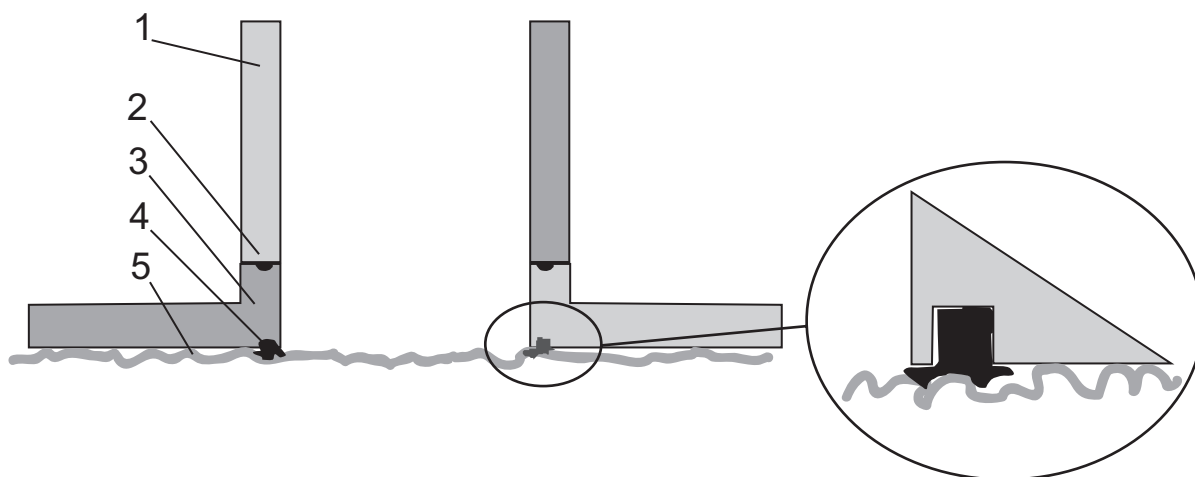

#### Key

- 1 wall of impedance tube
- 2 O-ring sealant between impedance tube and *in-situ* test fixture
- 3 *in-situ* test fixture
- 4 deformable sealing bead between *in-situ* test fixture and road surface
- 5 road surface

**Figure C.1 — Sketch of *in-situ* test fixture**

Broadening the fixture ring structure to a total diameter of about 0,2 m to 0,4 m improves the stability of the total system during *in-situ* measurements.





**Figure C.2 — Picture of the underside of the *in-situ* test fixture with a bead of sealing material applied**

## Annex D (informative)

### Example of a test report

#### ACOUSTIC TEST AS SPECIFIED IN ISO 13472-2

**Testing organization (name, address):** .....

**Date of the test:** .....

**Place of the test:** .....

**Description of the test site and measurement locations:** .....

.....

.....

#### **Description of the road surface under test:**

Age: ..... years.

Road surface conditions: Surface layer in good condition.

Composition: Dense asphalt concrete 0/8 mm in accordance with ISO 10844 recommendation.

Road surface dryness: Apparently dry; suspected slight water infiltration from adjacent areas.

Road surface temperature: 15 °C.

#### **Meteorological conditions prevailing during the test:**

Wind speed and direction: 4 m/s from S-E.

Ambient air temperature: 14 °C.

Atmospheric pressure: 101,5 kPa.

#### **Equipment used:**

Impedance tube system: ..... with *in-situ* test fixture .....

Microphones: ..... with power supply.

..... board equipped with ..... software for dual channel complex FFT analysis.

Portable computer .....

**Table — Results of the measurement in one-third-octave bands**

Frequency, Hz	250	315	400	500	630	800	1 000	1 250	1 600
Mean absorption coefficient	0,06	0,04	0,03	0,04	0,03	0,04	0,04	0,04	0,05
Standard deviation	0,01	0,02	0,01	0,015	0,02	0,01	0,01	0,018	0,02

Measurement uncertainty: expanded uncertainty with 80 % probability coverage: 0,022 in each one-third-octave band and with 95% probability coverage: 0,029 in each one-third octave band.

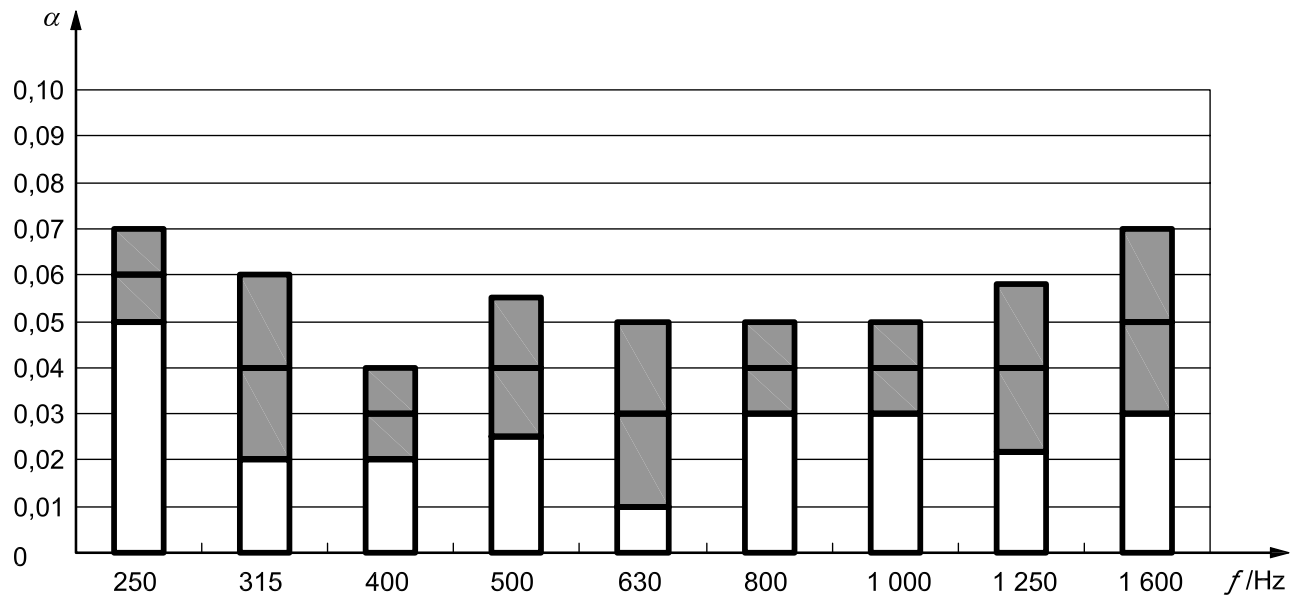

**Key**

- $f$  frequency
- $\alpha$  sound absorption coefficient at normal incidence

**Figure — Absorption coefficient, mean value, and standard deviation**

Date of the report: .....

Signature: .....

## Bibliography

- [1] ISO 354, *Acoustics — Measurement of sound absorption in a reverberation room*
- [2] ISO 362 (all parts), *Measurement of noise emitted by accelerating road vehicles — Engineering method*
- [3] ISO 7188, *Acoustics — Measurement of noise emitted by passenger cars under conditions representative of urban driving*
- [4] ISO 10534-1, *Acoustics — Determination of sound absorption coefficient and impedance in impedance tubes — Part 1: Method using standing wave ratio*
- [5] ISO 13472-1, *Acoustics — Measurement of sound absorption properties of road surfaces in situ — Part 1: Extended surface method*
- [6] IEC 61672 (all parts), *Electroacoustics — Sound level meters*
- [7] ASTM E1050, *Standard test method for impedance and absorption of acoustical materials using a tube, two microphones, and a digital frequency analysis system*



---

---

**ICS 17.140.30; 93.080.20**

Price based on 20 pages



# British Standards Institution (BSI)

BSI is the independent national body responsible for preparing British Standards and other standards-related publications, information and services.

It presents the UK view on standards in Europe and at the international level.

It is incorporated by Royal Charter.

## Revisions

British Standards are updated by amendment or revision. Users of British Standards should make sure that they possess the latest amendments or editions.

It is the constant aim of BSI to improve the quality of our products and services. We would be grateful if anyone finding an inaccuracy or ambiguity while using this British Standard would inform the Secretary of the technical committee responsible, the identity of which can be found on the inside front cover.

**Tel: +44 (0)20 8996 9001 Fax: +44 (0)20 8996 7001**

BSI offers Members an individual updating service called PLUS which ensures that subscribers automatically receive the latest editions of standards.

**Tel: +44 (0)20 8996 7669 Fax: +44 (0)20 8996 7001**

**Email: [plus@bsigroup.com](mailto:plus@bsigroup.com)**

## Buying standards

You may buy PDF and hard copy versions of standards directly using a credit card from the BSI Shop on the website [www.bsigroup.com/shop](http://www.bsigroup.com/shop). In addition all orders for BSI, international and foreign standards publications can be addressed to BSI Customer Services.

**Tel: +44 (0)20 8996 9001 Fax: +44 (0)20 8996 7001**

**Email: [orders@bsigroup.com](mailto:orders@bsigroup.com)**

In response to orders for international standards, it is BSI policy to supply the BSI implementation of those that have been published as British Standards, unless otherwise requested.

## Information on standards

BSI provides a wide range of information on national, European and international standards through its Knowledge Centre.

**Tel: +44 (0)20 8996 7004 Fax: +44 (0)20 8996 7005**

**Email: [knowledgecentre@bsigroup.com](mailto:knowledgecentre@bsigroup.com)**

Various BSI electronic information services are also available which give details on all its products and services.

**Tel: +44 (0)20 8996 7111 Fax: +44 (0)20 8996 7048**

**Email: [info@bsigroup.com](mailto:info@bsigroup.com)**

BSI Subscribing Members are kept up to date with standards developments and receive substantial discounts on the purchase price of standards. For details of these and other benefits contact Membership Administration.

**Tel: +44 (0)20 8996 7002 Fax: +44 (0)20 8996 7001**

**Email: [membership@bsigroup.com](mailto:membership@bsigroup.com)**

Information regarding online access to British Standards via British Standards Online can be found at [www.bsigroup.com/BSOL](http://www.bsigroup.com/BSOL)

Further information about BSI is available on the BSI website at [www.bsigroup.com/standards](http://www.bsigroup.com/standards)

## Copyright

Copyright subsists in all BSI publications. BSI also holds the copyright, in the UK, of the publications of the international standardization bodies. Except as permitted under the Copyright, Designs and Patents Act 1988 no extract may be reproduced, stored in a retrieval system or transmitted in any form or by any means – electronic, photocopying, recording or otherwise – without prior written permission from BSI. This does not preclude the free use, in the course of implementing the standard of necessary details such as symbols, and size, type or grade designations. If these details are to be used for any other purpose than implementation then the prior written permission of BSI must be obtained. Details and advice can be obtained from the Copyright & Licensing Manager.

**Tel: +44 (0)20 8996 7070**

**Email: [copyright@bsigroup.com](mailto:copyright@bsigroup.com)**

### BSI Group Headquarters

389 Chiswick High Road London W4 4AL UK

Tel +44 (0)20 8996 9001

Fax +44 (0)20 8996 7001

[www.bsigroup.com/standards](http://www.bsigroup.com/standards)