

Acoustics — Measurement of sound absorption properties of road surfaces *in situ* —

Part 1: Extended surface method

ICS 17.140.30; 93.080.20

National foreword

This British Standard reproduces verbatim ISO 13472-1:2002 and implements it as the UK national standard.

The UK participation in its preparation was entrusted by Technical Committee EH/1, Acoustics, to Subcommittee EH/1/2, Transport noise, which has the responsibility to:

- aid enquirers to understand the text;
- present to the responsible international/European committee any enquiries on the interpretation, or proposals for change, and keep the UK interests informed;
- monitor related international and European developments and promulgate them in the UK.

A list of organizations represented on this subcommittee can be obtained on request to its secretary.

Cross-references

The British Standards which implement international publications referred to in this document may be found in the *BSI Catalogue* under the section entitled “International Standards Correspondence Index”, or by using the “Search” facility of the *BSI Electronic Catalogue* or of British Standards Online.

This publication does not purport to include all the necessary provisions of a contract. Users are responsible for their correct application.

Compliance with a British Standard does not of itself confer immunity from legal obligations.

This British Standard, having been prepared under the direction of the Health and Environment Sector Policy and Strategy Committee, was published under the authority of the Standards Policy and Strategy Committee on 19 July 2002

Summary of pages

This document comprises a front cover, an inside front cover, the ISO title page, pages ii to vi, pages 1 to 26, an inside back cover and a back cover.

The BSI copyright date displayed in this document indicates when the document was last issued.

Amendments issued since publication

Amd. No.	Date	Comments

© BSI 19 July 2002

ISBN 0 580 39089 6

INTERNATIONAL
STANDARD

ISO
13472-1

First edition
2002-06-15

**Acoustics — Measurement of sound
absorption properties of road surfaces *in
situ* —**

**Part 1:
Extended surface method**

*Acoustique — Mesurage in situ des propriétés d'absorption acoustique des
revêtements de chaussées —*

Partie 1: Méthode de la surface étendue



Reference number
ISO 13472-1:2002(E)

Contents

	Page
1 Scope	1
2 Normative references	1
3 Terms and definitions	1
4 Summary of the method	3
4.1 General principle	3
4.2 Signal separation techniques	4
4.3 Test method	6
5 Test system	7
5.1 Components of the test system	7
5.2 Sound source	7
5.3 Test signal	7
6 Data processing	7
6.1 Calibration	7
6.2 Sampling frequency	7
6.3 Recovery of the overall impulse response	7
6.4 Temporal separation of the signals	8
7 Positioning of the equipment	8
7.1 Maximum sampled area	8
7.2 Positioning of the measuring equipment	8
7.3 Reflecting objects	9
7.4 Background noise	9
7.5 Safety considerations	9
8 Road surface and meteorological conditions	9
8.1 Condition of the road surface	9
8.2 Wind	9
8.3 Temperature	9
9 Measurement procedure	10
10 Measurement uncertainty	10
11 Test report	11
Annexes	
A Radius of the maximum sampled area	12
B Reference measurement and correction procedure.....	13
C Physical principle of the measurement	14
D Measurement using an MLS test signal.....	16
E Example of a test report.....	18
F Sound absorption coefficient at non-normal incidence	21

G Correction of small time shifts in the direct impulse response between the free-field measurement and the reflected measurement	23
Bibliography	26

Foreword

ISO (the International Organization for Standardization) is a worldwide federation of national standards bodies (ISO member bodies). The work of preparing International Standards is normally carried out through ISO technical committees. Each member body interested in a subject for which a technical committee has been established has the right to be represented on that committee. International organizations, governmental and non-governmental, in liaison with ISO, also take part in the work. ISO collaborates closely with the International Electrotechnical Commission (IEC) on all matters of electrotechnical standardization.

International Standards are drafted in accordance with the rules given in the ISO/IEC Directives, Part 3.

Draft International Standards adopted by the technical committees are circulated to the member bodies for voting. Publication as an International Standard requires approval by at least 75 % of the member bodies casting a vote.

Attention is drawn to the possibility that some of the elements of this part of ISO 13472 may be the subject of patent rights. ISO shall not be held responsible for identifying any or all such patent rights.

International Standard ISO 13472-1 was prepared by Technical Committee ISO/TC 43, *Acoustics*, Subcommittee SC 1, *Noise*.

ISO 13472 consists of the following parts, under the general title *Acoustics — Measurement of sound absorption properties of road surfaces* in situ:

— *Part 1: Extended surface method*

Other parts are in preparation.

Annexes A and B form a normative part of this part of ISO 13472. Annexes C, D, E, F and G are for information only.

Introduction

This part of ISO 13472 describes a test method for measuring, *in situ*, the sound absorption coefficient of road surfaces as a function of frequency under normal incidence.

This method provides a means of evaluating the sound absorption characteristics of a road surface without damaging the surface. It is intended to be used during road construction, road maintenance and other traffic noise studies. It may also be used to qualify the absorption characteristics of road surfaces used for vehicle and tyre testing. However, the standard uncertainty is limited to 0,05.

This method in this part of ISO 13472 is based on free-field propagation of the test signal from the source to the road surface and back to the receiver, and covers an area of approximately 3 m² and a frequency range, in one-third-octave bands, from 250 Hz to 4 kHz.

To complement this method, a spot method (will be part 2) is under development. This method is based on the transmission of the test signal from the source to the road surface and back to the receiver inside a tube and covers an area of approximately 0,1 m² and a frequency range, in one-third-octave bands, from 315 Hz to 2 kHz.

Both methods should give the same results in the frequency range from 315 Hz to 2 kHz.

They are both applicable also to acoustic materials other than road surfaces.

The measurement results of this method are comparable with the results of impedance tube methods, performed on bore cores taken from the surface (e.g. ISO 10534-1 and ISO 10534-2).

The measurement results of this method are in general not comparable with the results of the reverberation room method (ISO 354), because the method described in this part of ISO 13472 uses a directional sound field, while the reverberation room method assumes a diffuse sound field.

Acoustics — Measurement of sound absorption properties of road surfaces *in situ* —

Part 1: Extended surface method

1 Scope

This part of ISO 13472 describes a test method for measuring *in situ* the sound absorption coefficient of road surfaces as a function of frequency in the range from 250 Hz to 4 kHz.

Normal incidence is assumed. However, the test method can be applied at oblique incidence although with some limitations (see annex F). The test method is intended for the following applications:

- determination of the sound absorption properties of test tracks according to ISO 10844, with limitations, and other similar standards;
- determination of the sound absorption properties of road surfaces in actual use;
- comparison of sound absorption design specifications of road surfaces with actual performance data of the surface after completion of the construction work.

The complex reflection factor can also be determined by this method.

2 Normative references

The following normative documents contain provisions which, through reference in this text, constitute provisions of this part of ISO 13472. For dated references, subsequent amendments to, or revisions of, any of these publications do not apply. However, parties to agreements based on this part of ISO 13472 are encouraged to investigate the possibility of applying the most recent editions of the normative documents indicated below. For undated references, the latest edition of the normative document referred to applies. Members of ISO and IEC maintain registers of currently valid International Standards.

ISO 10534-1, *Acoustics — Determination of sound absorption coefficient and impedance in impedance tubes — Part 1: Method using standing wave ratio*

ISO 10534-2, *Acoustics — Determination of sound absorption coefficient and impedance in impedance tubes — Part 2: Transfer-function method*

IEC 60651, *Electroacoustics — Sound level meters*

IEC 61260, *Electroacoustics — Octave and fractional-octave-band filters*

GUM:1993, *Guide to the expression of uncertainty in measurement*. BIPM, IEC, IFCC, ISO, IUPAC, IUPAP, OIML

3 Terms and definitions

For the purposes of this part of ISO 13472, the following terms and definitions apply.

3.1

angle of incidence

angle between the normal to the surface under test and the direction of the sound wave impinging on the test surface

3.2

sound power reflection factor

Q_W
fraction of the impinging sound power which is reflected from the surface material of the road (see 3.4)

3.3

sound absorption coefficient

α
ratio of the sound power entering the surface of the test object (without return) to the incident sound power:

$$\alpha = 1 - Q_W$$

3.4

sound pressure reflection factor

Q_p
complex ratio of the pressure amplitude of the reflected wave to the pressure amplitude of the incident wave at the surface of the road

NOTE This quantity is necessary in order to understand the correction procedure described in annex B. The sound power reflection factor is equal to the squared modulus of the sound pressure reflection factor: $Q_W(f) = |Q_p(f)|^2$.

3.5

geometrical spreading factor

attenuation of the magnitude of a sound pressure wave travelling from one point to another due to the spherical spreading

3.6

plane of reference for the road surface

hypothetical plane tangential to the majority of the elements of the surface under test

3.7

maximum sampled area

surface area, contained within the plane of reflection, which must remain free of reflecting objects causing parasitic reflections (see annex A)

3.8

background noise

noise coming from sources other than the test signal

3.9

signal-to-noise ratio

S/N
difference, in decibels, between the level of the nominal useful signal and the level of the background noise at the moment of detection of the useful event

3.10

impulse response

time signal at the output of a system when a Dirac function is applied to the input

NOTE The Dirac function, also called δ function, is the mathematical idealization of a signal infinitely short in time which carries a unit amount of energy.

3.11

transfer function

Fourier transform of the impulse response

4 Summary of the method

4.1 General principle

A sound source driven by a signal generator is positioned above the surface to be tested and a microphone is located between the source and the surface. The measurement method is based on the assessment of the transfer function between the output of the signal generator and the output of the microphone. This transfer function is composed of two factors, one coming from the direct path (from the signal generator through the amplifier and loudspeaker to the microphone) and a second coming from the reflected path (from the signal generator through the amplifier, loudspeaker and surface under test to the microphone) (see Figure 1).

The overall impulse response containing the direct and reflected sound is measured in the time domain. This overall impulse response consists of the impulse response of the direct path and, after some delay due to the longer travelling distance, the impulse response of the reflected path.

With suitable time domain processing (e.g. signal subtraction and temporal separation, see 4.2), these responses can be separated. After a Fourier transform, the transfer functions of the direct path $H_i(f)$ and of the reflected path $H_r(f)$ are obtained. The ratio of the squared modulus of these transfer functions gives the sound power reflection factor $Q_W(f)$ from which the sound absorption coefficient can be calculated (see clause 3), apart from a factor K_r due to geometrical spreading.

Taking into account also this factor K_r due to geometrical spreading, the sound absorption coefficient is computed as:

$$\alpha(f) = 1 - Q_W(f) = 1 - \frac{1}{K_r^2} \left| \frac{H_r(f)}{H_i(f)} \right|^2$$

where

$$K_r = \frac{d_s - d_m}{d_s + d_m}$$

d_s is the distance between the sound source and the reference plane for the surface under test;

d_m is the distance between the microphone and the reference plane for the surface under test.

NOTE The complex reflection factor, necessary for propagation calculations or comparison of measurement results with theoretical calculations can be found as follows:

$$Q_p(f) = \frac{1}{K_r} \cdot \frac{H_r(f)}{H_i(f)} \cdot \exp(i2\pi\Delta\tau)$$

with $\Delta\tau$ the time difference between arrival of the direct and the reflected impulses.

No special requirement is placed upon the signal source as long as it enables determination of the impulse response over the designated frequency interval (see also 5.2).

The method considers the part of the energy that is reflected in a non-specular way as being absorbed. Thus, the sound absorption coefficient may be slightly overestimated.

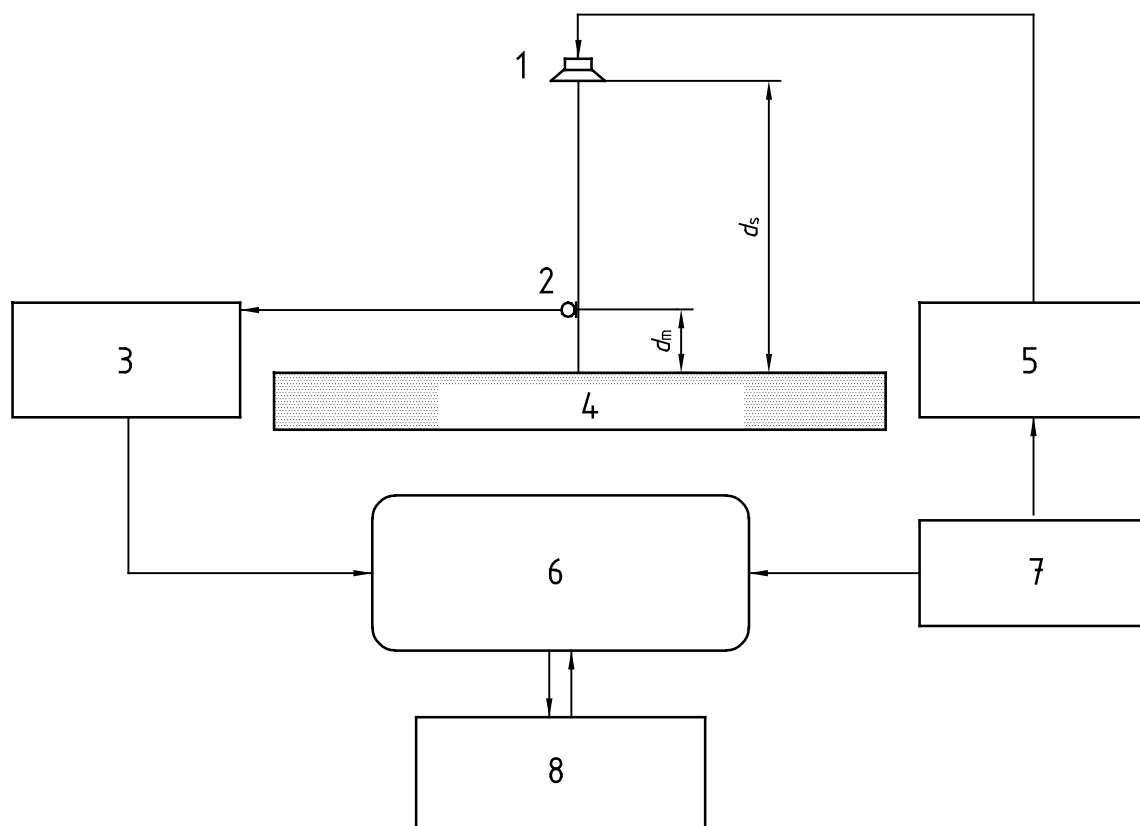

Key

- 1 Sound source
- 2 Microphone
- 3 Microphone amplifier
- 4 Surface under test
- 5 Loudspeaker amplifier
- 6 Impulse response time windows and Fourier transform
- 7 Signal generation
- 8 Analyser or computer

Figure 1 — Sketch of the essential components of the measurement set-up

4.2 Signal separation techniques

This part of ISO 13472 specifies how the sound source and the microphone shall be positioned over the surface under test and how the overall impulse response shall be measured.

The impulse response consists of a direct path component, a reflected path component coming from the surface under test and other parasitic components [see Figure 3 a)]. The separation of those different components can be achieved in two different ways.

- a) Temporal separation: if geometry is arranged such that a sufficient time delay exists between the arrival of the direct and reflected time signals, the relevant components can be extracted from the overall impulse response by application of time windows. Figure 2 shows a simple time separation technique for the case where the geometry is arranged such that the reflected component occurs after the direct one has decayed to zero.
- b) Signal subtraction technique: the impulse response of the direct path is not extracted from the overall impulse response; instead, it is removed from the overall impulse response by subtraction of an identical signal (see Figure 3).

The subtraction technique is preferred over temporal separation because it allows a longer sampling interval (necessary for low-frequency measurements) within a certain geometrical size of the system. Furthermore the microphone can be placed closer to the road surface so as to improve the S/N ratio and decrease the effect of geometrical spreading. Therefore in this part of ISO 13472 the subtraction technique is required.

The distance d_m between the microphone and the plane of reference for the surface under test can be relatively small. For source and microphone distances from the plane of reference for the road surface, this part of ISO 13472 requires the following values: $d_s = 1,25$ m and $d_m = 0,25$ m (see Figure 1). These distances shall be kept constant during the averaging process ($\pm 0,005$ m).

The direct impulse response has to be exactly known in shape, amplitude and time delay. This is obtained by performing a free-field measurement using the same geometrical configuration of the loudspeaker and the microphone. In particular, the distance between them shall be kept strictly constant. This requirement can be met by using a fixed and stable connection between the source and the microphone. If the direct impulse response has been subjected to a small time shift between the free field measurement and the reflection measurement, this shall be corrected for (see annex G).

In order to avoid temperature differences between the free field measurement and the measurement on the surface under test, it is recommended to perform the two measurements within a short time (less than 10 min).

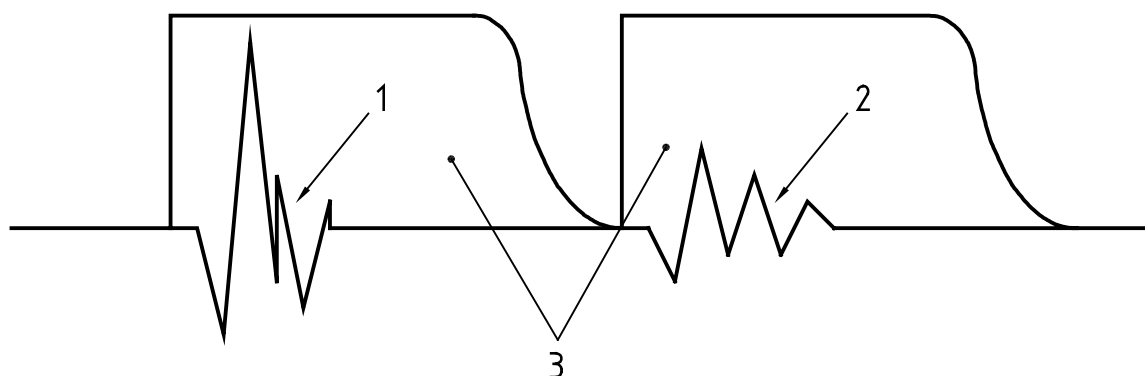

Key

- 1 Direct component
- 2 Reflected component
- 3 Time window ($T_{w,direct} = T_{w,reflected}$)

Figure 2 — Example of separation of the impulse response of the direct and the reflected path using time windows

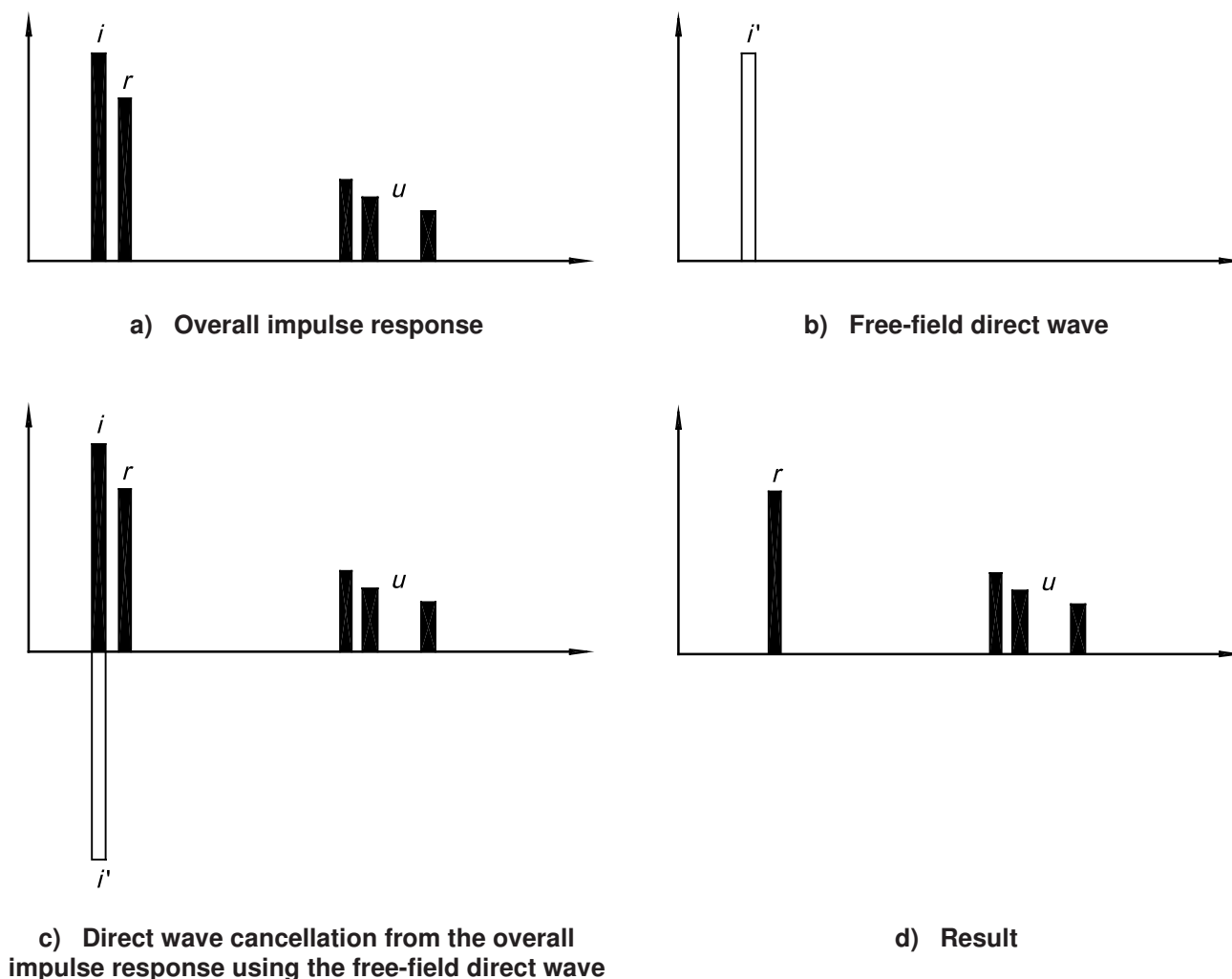

- i is the direct incident wave
- r is the reflected wave
- u is unwanted parasitic reflections
- i' is the free-field direct wave

Figure 3 — Principle of the signal subtraction technique

4.3 Test method

The measurement shall take place in an essentially free field, i.e. a field free from reflections coming from objects other than the surface under test. However, the use of a time window cancels out reflections arriving after a certain time period, and thus originating from locations further away than a certain distance (see clause 7).

In order to minimize the effects of the background noise and meteorological variations, it is recommended that at least 50 impulse responses be acquired and averaged.

Often, very small sound absorption values are measured in the low-frequency range. Accurate values in this range are very difficult to obtain. Small variations in the assessment of the sound pressure levels of both the direct signal and the reflected signal can induce high inaccuracies in the sound absorption values. In order to avoid this problem, and in order to improve the accuracy of the method, a reference measurement on a totally reflective surface shall be performed (see annex B).

5 Test system

5.1 Components of the test system

The test equipment shall comprise an electroacoustic system, consisting of an electronic signal generator, a power amplifier and a loudspeaker, a microphone with amplifier and a signal analyser capable of performing cross-correlation and transformations between the time and the frequency domains.

A sketch of the essential components of the measuring system is shown in Figure 1.

The complete measuring system shall meet the requirements of at least a type 2 instrument in accordance with IEC 60651. For the purposes of this part of ISO 13472, the measurement frequency range is displayed in one-third-octave bands, from 250 Hz to 4 kHz.

5.2 Sound source

The loudspeaker shall

- have either a single or a coaxial cone in a closed cabinet, and
- have a smooth frequency response without sharp irregularities throughout the measurement frequency range, resulting in an impulse response under free-field conditions with a length not greater than 2 ms.

5.3 Test signal

The test signal shall consist of a repeatable short signal with a low peak-to-RMS ratio, typically below 2, and an energy content that covers the one-third-octave bands from 250 Hz up to 4 kHz with an acceptable S/N ratio. Several signals may be used, such as maximum-length sequences (MLS, see annex D) or short frequency sweeps.

6 Data processing

6.1 Calibration

The measurement procedure described in this part of ISO 13472 is based on the power ratio of two transfer functions extracted from the same electroacoustical chain. An absolute calibration of the measurement chain with regard to the sound pressure level is, therefore, unnecessary. However, a reference measurement as described in annex B is required.

6.2 Sampling frequency

The subtraction principle implies knowledge of the exact wave form, especially for checking change of time delays in the measurement chain. The sampling frequency f_s shall therefore have a value greater than 40 kHz.

NOTE Although the signal is already unambiguously defined when the Nyquist criterion is met, higher sampling frequencies facilitate a clear reproduction of the signal. Errors can be detected and corrected more easily, such as corrections needed to account for time shifts due to temperature changes.

6.3 Recovery of the overall impulse response

The overall impulse response is obtained through a cross-correlation between the electronic source signal and the received microphone signal (see annex D).

6.4 Temporal separation of the signals

Before measurements, it shall be ensured that no parasitic signals appear in the temporal windows (see 7.3).

The separation of the direct and the reflected signals is obtained by applying the signal subtraction technique (see 4.2).

The low-frequency limit of the analysis is proportional to the reciprocal of the width of the narrowest temporal window used. A 220 Hz lower limit implies a minimum length of approximately 5 ms.

The temporal window shall be suitably shaped, with a sharp leading edge, a 5 ms flat portion followed by a suitable trailing edge (e.g. a cosine squared or Blackman-Harris), so as to suppress signal oscillations in the frequency domain (see Figure 4).

In every case the shape and the lengths of the selected temporal window shall be reported in the test report.

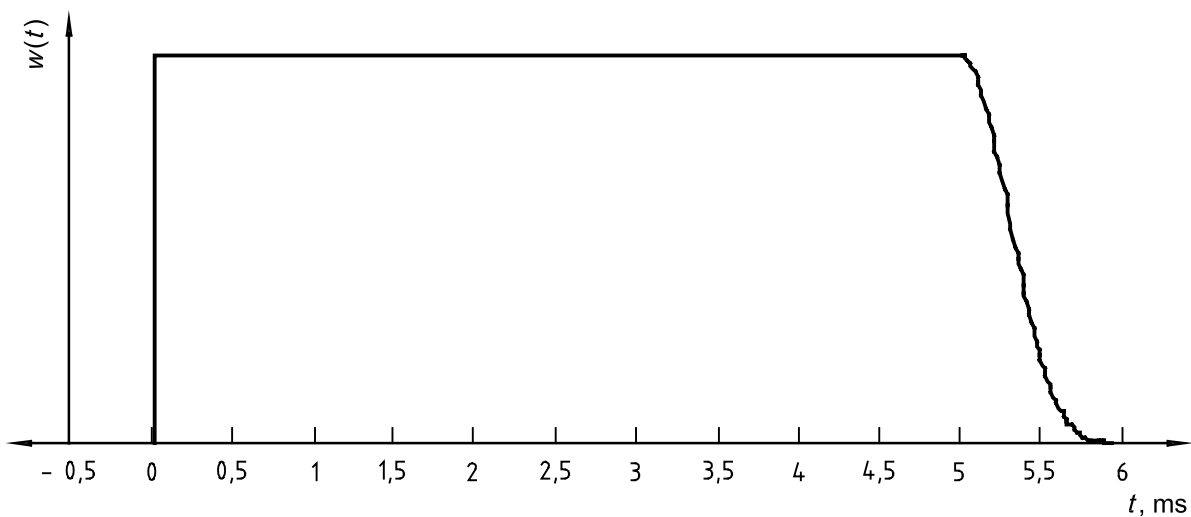

Figure 4 — Example of temporal window

7 Positioning of the equipment

7.1 Maximum sampled area

The size of the maximum sampled area is defined by the distances from the sound source and the microphone to the surface under test, together with the length of the time window. For normal incidence, the maximum sampled area is bounded by a circle with its centre at the point of incidence and radius r given by the relationship in annex A.

The mandatory reference surface shall at least comprise the MSA (see annex B).

7.2 Positioning of the measuring equipment

The measuring equipment shall be placed above the surface under test or above the reference surface according to the arrangement as shown in Figure 1 and the positions given in 4.2.

The sound source shall be located at a height d_s of 1,25 m above the plane of reference for the road surface. The receiver microphone shall be located at a height d_m of 0,25 m above the plane of reference for the road surface. The distances shall be kept constant to within 0,005 m.

The acoustic centre of the sound source and the acoustic centre of the microphone shall lie on a line normal to the plane of reference, and the axis of the microphone shall be parallel to the plane of reference.

This location of the source and the microphone shall be such that the maximum sampled area (see 7.1 and annex A) is totally included in the road surface under test.

7.3 Reflecting objects

Any object other than the road pavement shall be considered a reflecting object which could cause parasitic reflections (e.g. fences, rocks, anti-noise barriers, parked cars). These objects shall remain out of the maximum sampled area at a distance to the microphone greater than d_s .

Care shall be taken that the microphone stand does not influence the measurement.

7.4 Background noise

The signal-to-noise ratio S/N shall be larger than 10 dB within each one-third-octave band between 250 Hz and 4 kHz.

NOTE Coherent detection techniques, such as the MLS cross-correlation, provide high S/N ratios (see annex D).

7.5 Safety considerations

This test method may involve hazardous operations when measurements are performed on roads where there is traffic. This part of ISO 13472 does not purport to address all of the safety problems associated with its use. It is the responsibility of the user of this part of ISO 13472 to establish appropriate safety and health practices and determine the applicability of regulatory limitations prior to use.

8 Road surface and meteorological conditions

8.1 Condition of the road surface

The road surface under test shall be visually homogeneous and free of changes in the material properties.

Measurements shall not be carried out unless the road surface is dry. If the road surface can be expected to have a significant void content, then it should be verified that the pores are dry.

Measurements which for study or research purposes specifically aim at determining the influence of weather or other environmental conditions on sound absorption may be carried out when the road surface is not dry, but the results cannot be used for classification or qualification of the road surface under test.

8.2 Wind

The wind speed at microphone height shall not exceed 5 m/s during the measurements.

8.3 Temperature

The ambient air temperature shall be between 0 °C and 35 °C during the measurements. The road surface temperature shall be between 0 °C and 50 °C during the measurements.

9 Measurement procedure

The measurements shall be carried out as follows.

- a) Check the road surface and meteorological conditions to ensure compliance with the specifications in 8.1 to 8.3. Otherwise, the measurements cannot be carried out.
- b) Place the measuring equipment on site as specified in 7.2. The safety considerations given in 7.5 apply.
- c) Compute the radius of the maximum sampled area as specified in annex A. Check that no reflecting objects are inside the maximum sampled area. Otherwise, the measurements cannot be performed.
- d) Select the sound source and the test signal according to 5.2 and 5.3.
- e) Generate the test signal.
- f) Sample the total signal as received by the microphone with a sampling frequency selected according to 6.2.
- g) The microphone response data shall be repeatedly averaged until a stable impulse response function is obtained (at least 50 averages; see 4.3).
- h) Record the free-field impulse response with the measurement set-up removed from any reflecting surface which could influence the measurement and keeping the same geometrical configuration (see 4.2).
- i) Isolate the impulse response of the reflected path using the signal subtraction technique. Parasitic reflections are cancelled by a suitable temporal window (see 6.4).
- j) Multiply the direct impulse resonance and the reflected impulse resonance with a temporal window and compute the power spectra of the two signals extracted using time windows by means of Fourier transform. If it is necessary to calculate the complex reflection factor, the complex spectra should be used.
- k) Compute the sound power reflection factor (see 4.1 and annex C), taking into account the geometrical spreading factor as specified in 4.1.
- l) Repeat the whole procedure from point a) to point k) on a highly reflective reference surface, and apply the procedure specified in annex B.
- m) Compute the road surface sound absorption coefficient by linear averaging narrow band absorption in one-third-octave bands (see 4.1 and annex B).
- n) If necessary, repeat measurements at different points on the road surface.
- o) Write a measurement report (see clause 11 and also annex E).

10 Measurement uncertainty

The accuracy in the outcome of the measurement is limited due to several factors as follows.

- a) The zeroing out of the direct response will not be perfect, leading to a small but significant error.
- b) The reference surface will not be perfectly reflecting, especially when a portable construction is used.
- c) The measurement chain will not be absolutely stable, leading again to non-perfect zeroing of the direct response.
- d) Determination of the geometrical spreading factor K_r is implicitly based on the reference measurement situation with a reflective surface. In the case of thick absorptive surfaces, the plane of reflection is not unambiguously defined, which will lead to an underestimate of the reflection factor.
- e) Absorptive properties of the road surface can vary, leading to a non-representative measurement result.

In order to improve the accuracy in the case of highly reflective road surfaces, it is recommended to average several measurements on the same location until a stable result is obtained.

On the basis of experiences gained with the method a standard uncertainty of 0,05 over the entire frequency range can be expected under normal conditions. However, testing over the entire range of temperature and wind conditions allowed in this part of ISO 13472 and cases with thick absorptive layers can result in larger variations.

The uncertainty shall be stated in the test report. The uncertainty should be stated as the expanded uncertainty for a coverage probability of 95 %, e.g. $U = 0,1$ ($k = 2$) in accordance with GUM.

This part of ISO 13472 encourages the acquisition of additional environmental conditions, to improve the understanding of the influence of these factors on the measurements. This part of ISO 13472 also encourages the acquisition of additional data in order to improve the understanding of the possible effects of different instrumentation on the measurements.

11 Test report

The test report shall include the following information:

- a) reference to this part of ISO 13472;
- b) name and address of testing organization;
- c) date and place of the test;
- d) description of the test site: drawing or pictures showing the road surface under test, measurement set-up, reflecting objects near the maximum sampled area (if any);
- e) description of the road surface under test: age, measurement conditions, composition [number of layers, thickness(es), material specification, porosity, etc.];
- f) road surface conditions with regard to dryness and temperature;
- g) meteorological conditions prevailing during the test (wind speed and direction, air and road surface temperatures);
- h) test arrangement, indicating on a scale drawing or a sketch with dimensions marked on it the position(s) of the source and the microphone;
- i) equipment used for measurement and analysis, including name, type, serial number and manufacturer;
- j) description of the sound source used for the test (see 5.2);
- k) type and characteristics of the anti-aliasing filter and sample rate of the sampling/analysis device;
- l) shape and lengths of the temporal windows used for the analysis;
- m) test results;
- n) uncertainty of the test results;
- o) signature of the person responsible for the measurements.

The test results shall be given in the form of a graph and a table, showing the values of the sound absorption coefficient in one-third-octave frequency bands from 250 Hz up to 4 kHz. In addition, the test results may also be presented in narrow frequency bands.

The values of the sound absorption coefficient shall be rounded off to two decimal places.

An example of a test report is supplied in annex E.

Annex A (normative)

Radius of the maximum sampled area

The surface area, contained within the plane of reflection which shall remain free of reflecting objects causing parasitic reflections, is called the maximum sampled area. For normal incidence, the maximum sampled area is bounded by a circle with its centre at the point of incidence and radius r , in metres, given by the relationship:

$$r = \frac{1}{d_s + d_m + cT_w} \sqrt{\left(d_s + d_m + \frac{cT_w}{2}\right) \left(d_s + \frac{cT_w}{2}\right) (2d_m + cT_w) cT_w}$$

where

d_s is the distance from the sound source to the reflecting plane (m);

d_m is the distance from the microphone to the reflecting plane (m);

c is the speed of sound in air (m/s);

T_w is the width of the temporal window used to isolate the sound pressure wave reflected by the surface under test (s).

EXAMPLE With the values of d_s , d_m and T_w specified in this part of ISO 13472 and $c = 340$ m/s, the maximum sampled area radius is 1,34 m.

NOTE The radius of the surface area which contributes to the measured values of absorption is a decreasing function of frequency, but is not necessarily equal to the radius of the maximum sampled area previously defined. A calculation of the radii of the Fresnel zones in the plane of the sample will assist the determination of the area of influences across the range of frequencies of interest.

Annex B (normative)

Reference measurement and correction procedure

The reference measurement shall be performed on a highly reflecting surface with at least the same size as the maximum sampled area. The highly reflecting reference surface shall be a plane smooth dense surface without joints. If a portable surface is applied, it shall be clear that no movement of the surface is possible which might lead to resonant absorption of the surface.

The measured sound pressure reflection factor $Q_{p,\text{ref,meas}}(f)$ is considered to be the product of the reflection factor of the reference surface, $Q_{p,\text{ref}}(f)$, and the error function, $e(f)$:

$$Q_{p,\text{ref,meas}}(f) = Q_{p,\text{ref}}(f) e(f)$$

A sample of the reference surface material shall be measured in an impedance tube according to ISO 10534-1 or ISO 10534-2 to confirm that the reference surface may be considered as having an absorption coefficient lower than 0,05 in the measured frequency range.

If the reference surface is assumed to be totally reflective over the whole frequency range:

$$Q_{p,\text{ref}}(f) = 1$$

then the measurement gives directly the error function:

$$Q_{p,\text{ref,meas}}(f) = e(f)$$

A second measurement, this time performed on the road surface under test, gives the reflection factor $Q_{p,\text{road,meas}}(f)$ which, assuming that the error function does not vary during the time period between the two measurements, corresponds to:

$$Q_{p,\text{road,meas}}(f) = Q_{p,\text{road}}(f) e(f) = Q_{p,\text{road}}(f) \cdot Q_{p,\text{ref,meas}}(f)$$

and thus, $Q_{p,\text{road}}(f)$ being the reflection factor of the road surface under test:

$$Q_{p,\text{road}}(f) = \frac{Q_{p,\text{road,meas}}(f)}{Q_{p,\text{ref,meas}}(f)}$$

Recalling that the sound power reflection factor, $Q_{W,\text{road}}(f)$, is equal to the squared modulus of the sound pressure reflection factor $Q_{p,\text{road}}(f)$, the final sound absorption coefficient of the road surface becomes:

$$\alpha_{\text{road}}(f) = 1 - |Q_{p,\text{road}}(f)|^2 = 1 - \left| \frac{Q_{p,\text{road,meas}}(f)}{Q_{p,\text{ref,meas}}(f)} \right|^2 = 1 - \frac{Q_{W,\text{road,meas}}(f)}{Q_{W,\text{road,ref}}(f)}$$

Annex C (informative)

Physical principle of the measurement

The source emits a sound wave that travels past the microphone position to the surface under test where it reflects. The microphone placed between the sound source and the surface under test detects the direct sound pressure wave travelling from the sound source to the surface under test, followed by the sound pressure wave reflected by the surface under test.

The overall microphone response, $h_m(t)$, can be described by:

$$h_m(t) = h_i(t) + K_r h_i(t) * r_p(t - \Delta\tau) + \sum_j K_{r,j} h_i(t) * r_{p,j}(t - \Delta\tau_j) + h_n(t)$$

where

$h_i(t)$ is the impulse response of the direct path;

$r_p(t)$ is the reflection factor of the surface under test;

$h_n(t)$ is the background noise response;

$*$ is the convolution sign;

j denotes the “parasitic” reflections;

K_r is the geometrical spreading factor accounting for the path length difference between the direct and reflected paths (see Figure 1):

$$K_r = \frac{d_s - d_m}{d_s + d_m}$$

where

d_s is the distance between the sound source and the reflecting plane;

d_m is the distance between the microphone and the reflecting plane.

$\Delta\tau$ is the delay time, resulting from the path length difference between the direct and reflected paths, as detected by the microphone:

$$\Delta\tau = \frac{2d_m}{c}$$

where c is the speed of sound in air.

The overall microphone response $h_m(t)$ contains the impulse response of the reflected path coming from the surface under test:

$$h_r(t) = K_r H_i(t) * r_p(t - \Delta\tau)$$

The impulse response of the direct path $h_i(t)$ and impulse response of the reflected path coming from the surface under test $h_r(t)$ can be extracted from the overall microphone response in the time domain by using a suitable

windowing function, provided that the amplitude of $h_i(t)$ decays to an insignificant value with respect to $h_r(t)$ within the delay time $\Delta\tau$.

Alternatively, the impulse response of the direct path can be measured in a free field, keeping the distance of the microphone from the sound source strictly constant; then, the road surface response can be obtained using the subtraction technique as described in 4.2.

Fourier transform of the preceding expression for $h_r(t)$ yields the sound power reflection factor in the frequency domain:

$$|Q_p(f)|^2 = \frac{1}{K_r^2} \left| \frac{H_r(f)}{H_i(f)} \right|^2$$

where

$H_r(f)$ is the transfer function of the reflected path (from the signal generator through the amplifier, loudspeaker and reflection at the surface under test to the microphone);

$H_i(f)$ is the transfer function of the direct path (from the signal generator through the amplifier and loudspeaker to the microphone).

From here, the sound absorption coefficient can be computed:

$$\alpha(f) = 1 - |Q_p(f)|^2 = 1 - \frac{1}{K_r^2} \left| \frac{H_r(f)}{h_i(f)} \right|^2$$

Annex D (informative)

Measurement using an MLS test signal

D.1 The MLS test signal

To obtain an MLS signal as test signal, an electroacoustical sound source (loudspeaker) must be used, fed with an electrically generated maximum-length sequence (MLS), repeated continuously.

A maximum-length sequence (MLS) is a pseudo-random sequence of binary values conveniently generated recursively by a digital N -stage shift register with a feedback loop. N is called the order of the MLS. MLSs are deterministic and periodic. The period of an MLS is:

$$L = 2^N - 1$$

The larger is N , the larger are the number of points of the sampled overall microphone response, and the larger are the required memory and processing power.

D.2 Recovery of the overall impulse response

The pseudo-random MLS, $s(n\Delta t)$, is continuously fed to the sound source; one period of the stationary pseudo-random response picked up by the microphone is sampled. The sampling interval Δt must be the reciprocal of the clock rate of the MLS generator.

In order to recover the overall microphone response, the sampled microphone response, as electrically received by the analysis device

$$h_{m,pre}(n\Delta t) = s(n\Delta t) * h_m(n\Delta t) + h_n(n\Delta t)$$

must be periodically cross-correlated with the input MLS continuously fed to the sound source. This is equivalent to a convolution with the time-reversed MLS:

$$\Phi_{s,m}(n\Delta t) = \frac{1}{L+1} [s(n\Delta t) * h_m(n\Delta t) + h_n(n\Delta t)] * s(-n\Delta t) \approx h_m(n\Delta t)$$

where $\Phi_{s,m}(n\Delta t)$ denotes the circular cross-correlation between the MLS $s(n\Delta t)$ and the data received by the microphone, $h_{m,pre}(n\Delta t)$. Usually, this operation can be performed by the same electronic device used for generating the MLS. It could also be performed by a Fourier transform analyser receiving at its input both the MLS fed to the sound source and the sampled microphone response. A Fast Hadamard Transform (FHT) algorithm can be used.

D.3 Sampling rate and MLS time length

The sampling rate affects the duration of one cycle of the MLS signal emitted by the loudspeaker. In fact, the time length of one cycle of an MLS signal, T_s , depends on the length of the binary sequence, L , and on the time gap between two pulses, Δt , that is the reciprocal of the sampling rate:

$$T_s = L\Delta t = \frac{L}{f_s}$$

The values reported in Table D.1 usually enable good outdoor operations.

Table D.1 — Recommended values of some MLS parameters

MLS order N	MLS Length L	Filter cut-off freq. f_{co} kHz	Sampling rate f_s kHz	MLS signal length T_s s
15	32 767	10	44,1	0,74
15	32 767	10	48	0,68
15	32 767	10	56	0,59
15	32 767	10	75	0,44
16	65 535	10	44,1	1,49
16	65 535	10	48	1,37
16	65 535	10	56	1,17
16	65 535	10	75	0,87

D.4 Improvement of the signal-to-noise ratio

Measurements performed as stated before using an MLS signal should have an excellent background noise immunity, because the background noise picked up by the microphone when cross-correlated with the MLS (see D.2) gives in principle a result of zero.

In practice, the background noise may have a marginal influence, especially when measuring with a signal-to-noise ratio $S/N \leq 0$. In this case, the sampled impulse response can be further averaged by repeating the generation/sampling/cross-correlation cycle M times.

If M cycles of an MLS of length L are averaged, the S/N ratio is improved:

$$\Delta (S/N)_M = 10 \lg [LM]$$

The following formula enables determination of the number of averages M needed to reach a given degree of accuracy $E(L_{S+N} - L_S)$ of the sampled sound pressure level under a given S/N ratio:

$$E(L_{S+N} - L_S) = 10 \lg \left[1 + \frac{1}{M} \cdot \frac{1}{10^{S/N}} \right]$$

where

$E(\cdot)$ is the expected value of its argument;

L_{S+N} is the sound pressure level due to the recovered signal in the presence of the background noise;

L_S is the sound pressure level expected from the signal alone;

M is the number of averages, i.e. the number of MLS cycles.

Annex E (informative)

Example of a test report

ACOUSTIC TEST AS SPECIFIED IN INTERNATIONAL STANDARD ISO 13472-1

Testing organization (name, address): XXXXX.

Date of the test: 26 January 1998.

Place of the test: XXXXX.

Description of the test site:

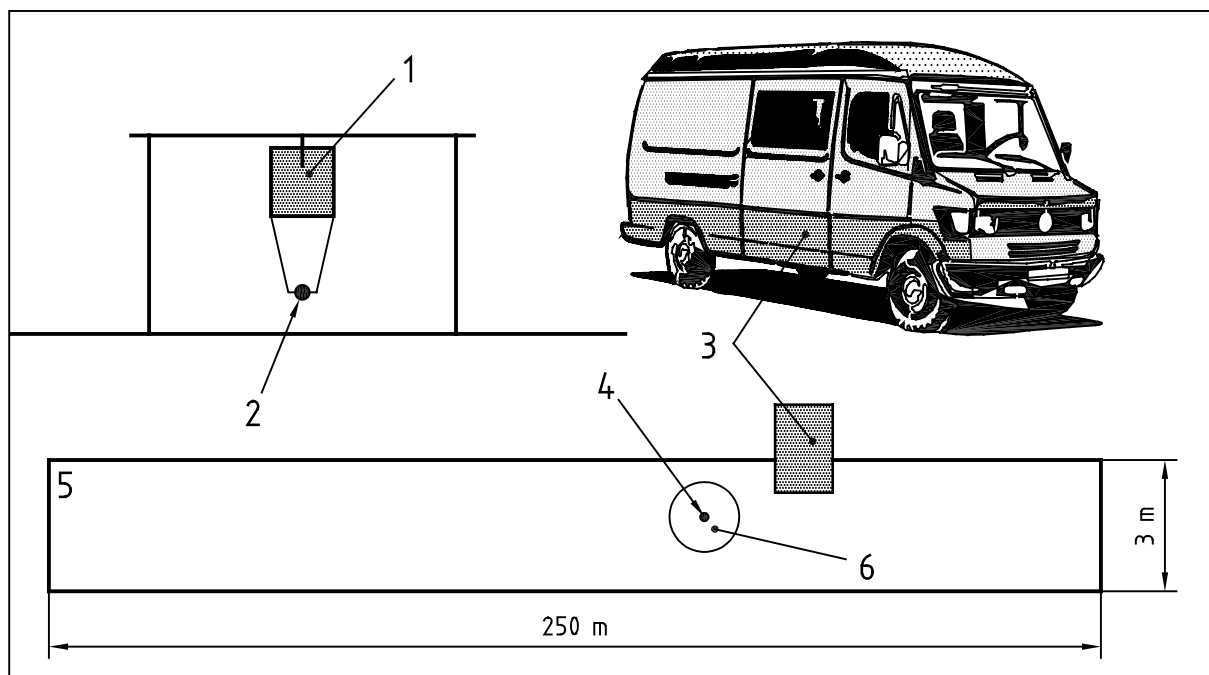

Key

- 1 Source
- 2 Microphone
- 3 Mobile laboratory (van)
- 4 Measurement point
- 5 Porous asphalt track
- 6 Maximum sampled area

Description of the road surface under test:

Age: 8 years.

Measurement conditions: surface layer in good condition.

Composition: porous asphalt: 0/10 mm;
 porosity: 20 %;
 thickness: 0,04 m.

Road surface dryness: apparently dry; suspected slight water infiltration from adjacent areas.

Road surface temperature: 5 °C.

Meteorological conditions prevailing during the test:

Wind speed and direction: 4 m/s from S-E.

Ambient air temperature: 4 °C.

Test arrangement (with dimensions):

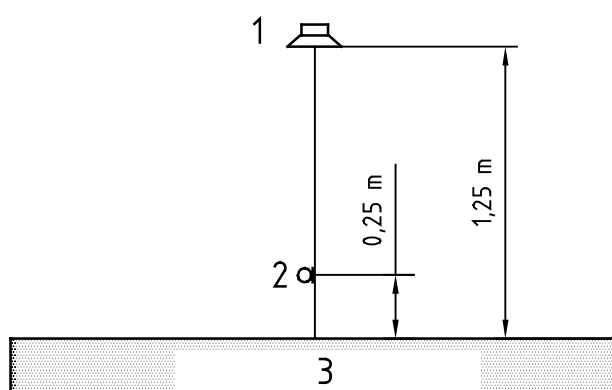

Key

- 1 Loudspeaker
- 2 Microphone
- 3 Surface under test

Equipment used:

Loudspeaker XXXXX in a closed cabinet.

Loudspeaker amplifier XXXXX.

Microphone: XXXXX with power supply.

XXXXX board equipped with XXXXX software for impulse response acquisition.

Software by XXXXX for on-site processing.

Portable computer XXXXX.

Sample rate: 75,5 kHz.

Temporal windows shape and length: Sharp leading edge; 5 ms flat portion; Blackman-Harris trailing edge.

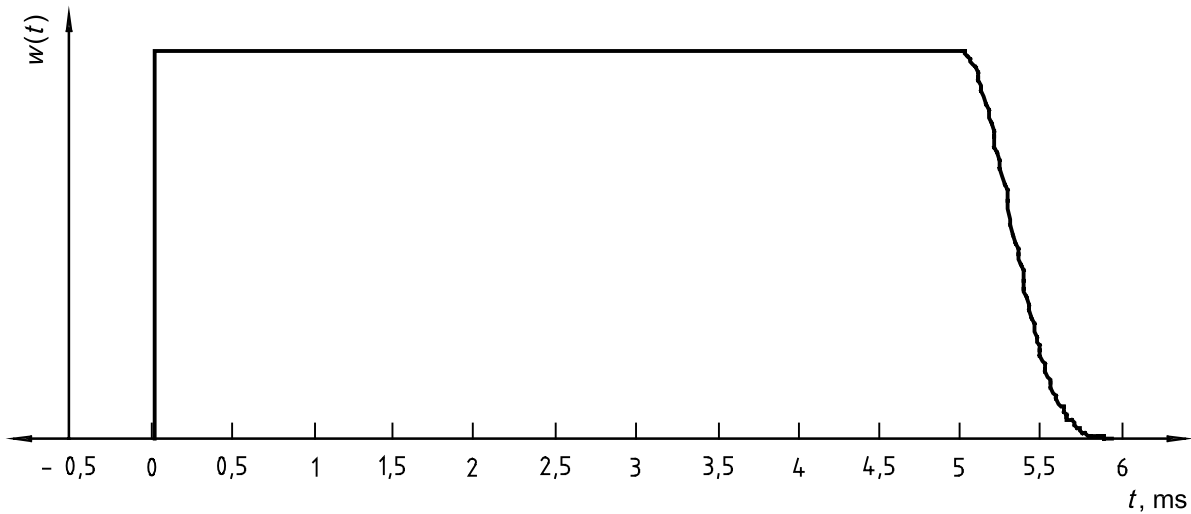

Results of the measurement in one-third-octave bands:

Hz	250	315	400	500	630	800	1 000	1 250	1 600	2 000	2 500	3 150	4 000
α	0,01	0,02	0,01	0,08	0,20	0,39	0,69	0,65	0,34	0,23	0,26	0,55	0,29

Measurement uncertainty (95 % confidence interval): 0,10.

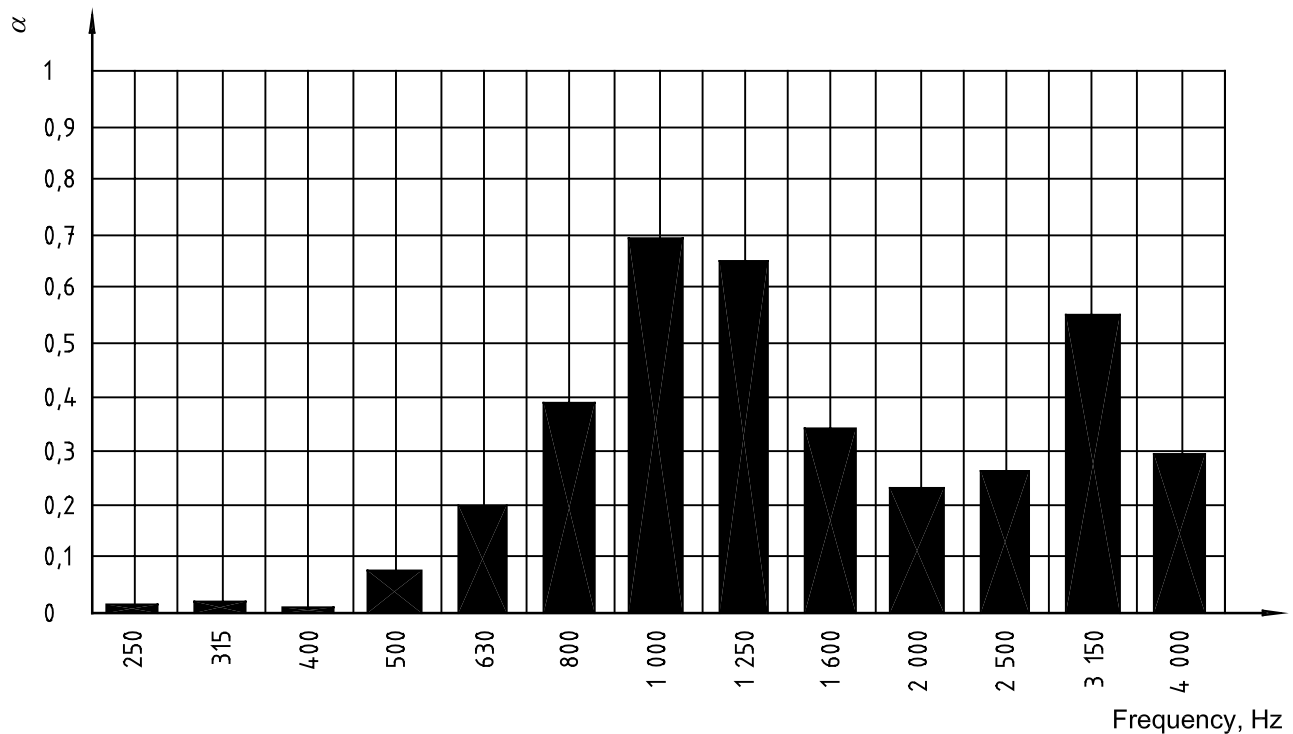

Date of the report: 26 February 1998.

Signature: XXXXX

Annex F (informative)

Sound absorption coefficient at non-normal incidence

Considering a sound source corresponding to the criteria given in 5.2, it is possible to determine the sound absorption coefficient at a non-normal incidence by the same theoretical procedure developed for the normal incidence. The difference concerns the geometrical arrangement of the source and the receiver as shown in Figure F.1. For the sake of simplicity, in this annex the same distance from the microphone to the road surface as for measurements at normal incidence are assumed.

For non-normal incidence, the maximum sampled area is the geometrical figure defined by the intersection between the plane of reference for the road surface and the ellipsoid of revolution, whose foci are the sound source position and the microphone position and whose major axis is given by:

$$a = cT_w + \sqrt{(d_s + d_m)^2 + d_p^2}$$

with the same symbols used in annex A, and d_p is the distance from the sound source to the microphone projected on the plane of reference for the road surface, in metres (see Figure F.1).

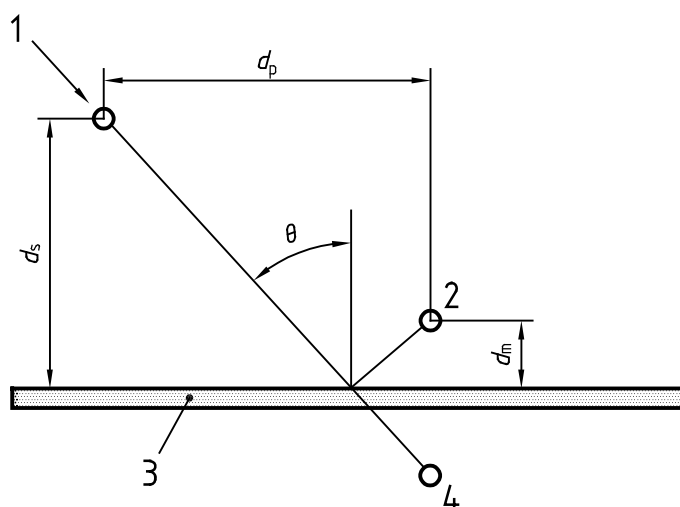

Key

- | | |
|---|---------------------|
| 1 | Sound source (S) |
| 2 | Receiver (R) |
| 3 | Surface under test |
| 4 | Image receiver (R') |

Figure F.1 — Sketch of the measurement set-up for non-normal incidence measurements

Considering the angle of incidence θ , the geometrical spreading factor $K_{r,\theta}$ accounting for the path length difference between the direct and the reflected signal is:

$$K_{r,\theta} = \frac{d(S,R)}{d(S,R')} = \frac{d(S,R)}{d(S,O,R)}$$

where

- S is the source;
- R is the receiver;
- O is the object;
- R' is the image receiver.

By application of geometrical properties, $d(S,R)$ and $d(S,O,R)$ can be given by the following relationships:

$$d(S,R) = \left[\left(\frac{d_s + d_m}{\cot \theta} \right)^2 + (d_s - d_m)^2 \right]^{\frac{1}{2}}$$

$$d(S,O,R) = \left(\frac{d_s + d_m}{\cos \theta} \right)$$

These relationships, introduced in the expression for the geometrical spreading factor $K_{r,\theta}$ give, after some calculations:

$$K_{r,\theta}^2 = 1 - \cos^2 \theta \left[1 - \left(\frac{d_s - d_m}{d_s + d_m} \right)^2 \right]$$

In annex C, the geometrical spreading factor at normal incidence K_r is defined as $\frac{d_s - d_m}{d_s + d_m}$. Thus, $K_{r,\theta}$ can be expressed as a function of K_r and θ :

$$K_{r,\theta}^2 = 1 - \cos^2 \theta (1 - K_r^2)$$

By application of the general formula given in 4.1, the sound absorption coefficient at the incidence angle θ , $\alpha_\theta(f)$, is equal to:

$$\alpha_\theta(f) = 1 - \frac{1}{K_{r,\theta}^2} \left| \frac{H_{r,\theta}(f)}{H_{i,\theta}(f)} \right|^2$$

where

- $H_{r,\theta}(f)$ is the transfer function of the reflected path (from the signal generator through the amplifier, loudspeaker and reflection at the surface under test to the microphone);
- $H_{i,\theta}(f)$ is the transfer function of the direct path (from the signal generator through the amplifier and loudspeaker to the microphone).

To improve accuracy, a measurement on a highly reflective reference surface should be performed using identical geometry. The correction to the measured value described in annex B should then be applied.

Annex G (informative)

Correction of small time shifts in the direct impulse response between the free-field measurement and the reflected measurement

It is recommended that the impulse responses of the free field and of the reflected measurement are compared to check that the size and the position of the direct part has not changed between the two measurements. The direct part can in general be clearly distinguished from the reflected path (see Figure G.1). An offset in the loudspeaker cone, a change in orientation, or temperature differences occurring between the free field and the reflected measurements can cause a time shift that can be corrected for.

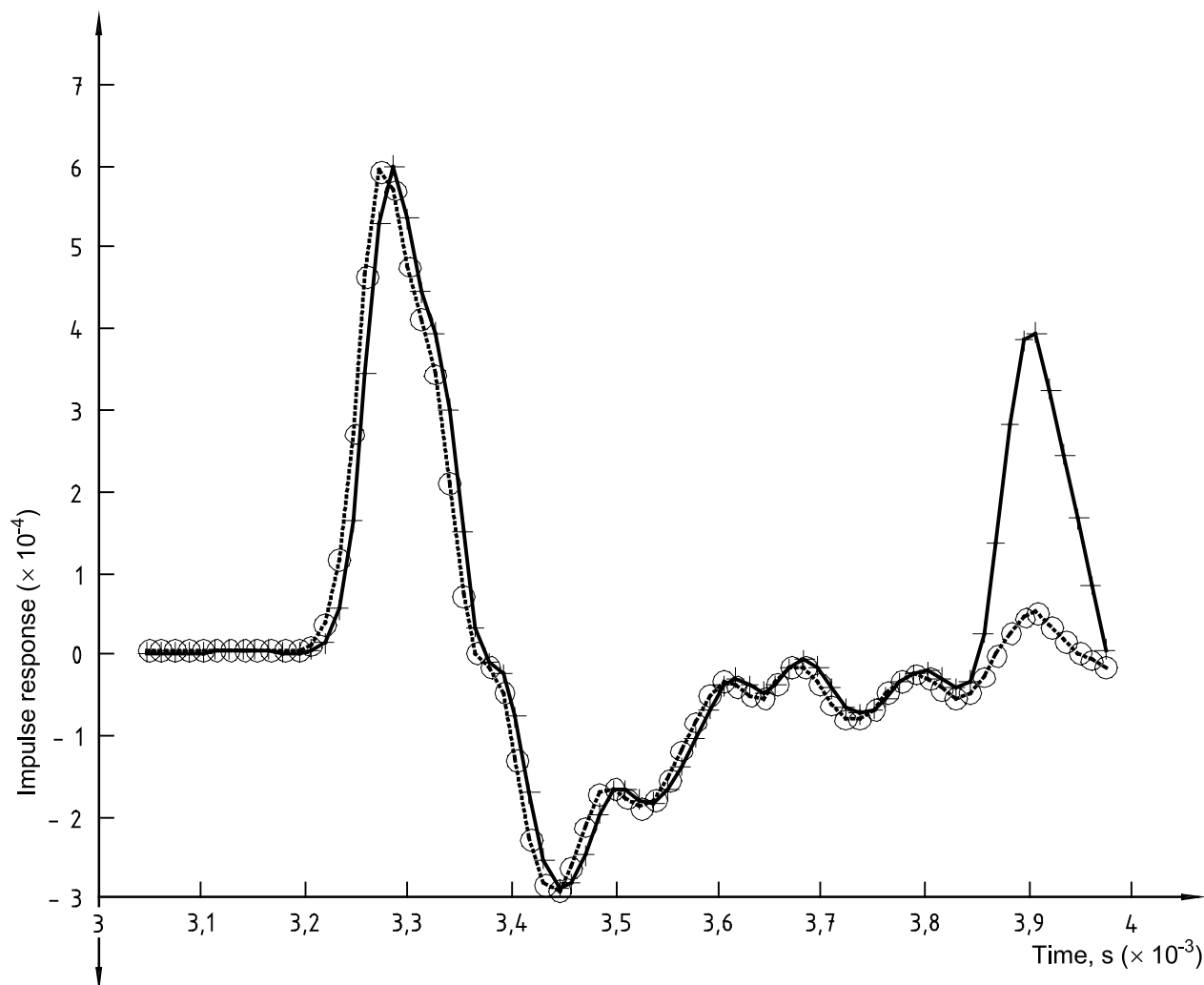
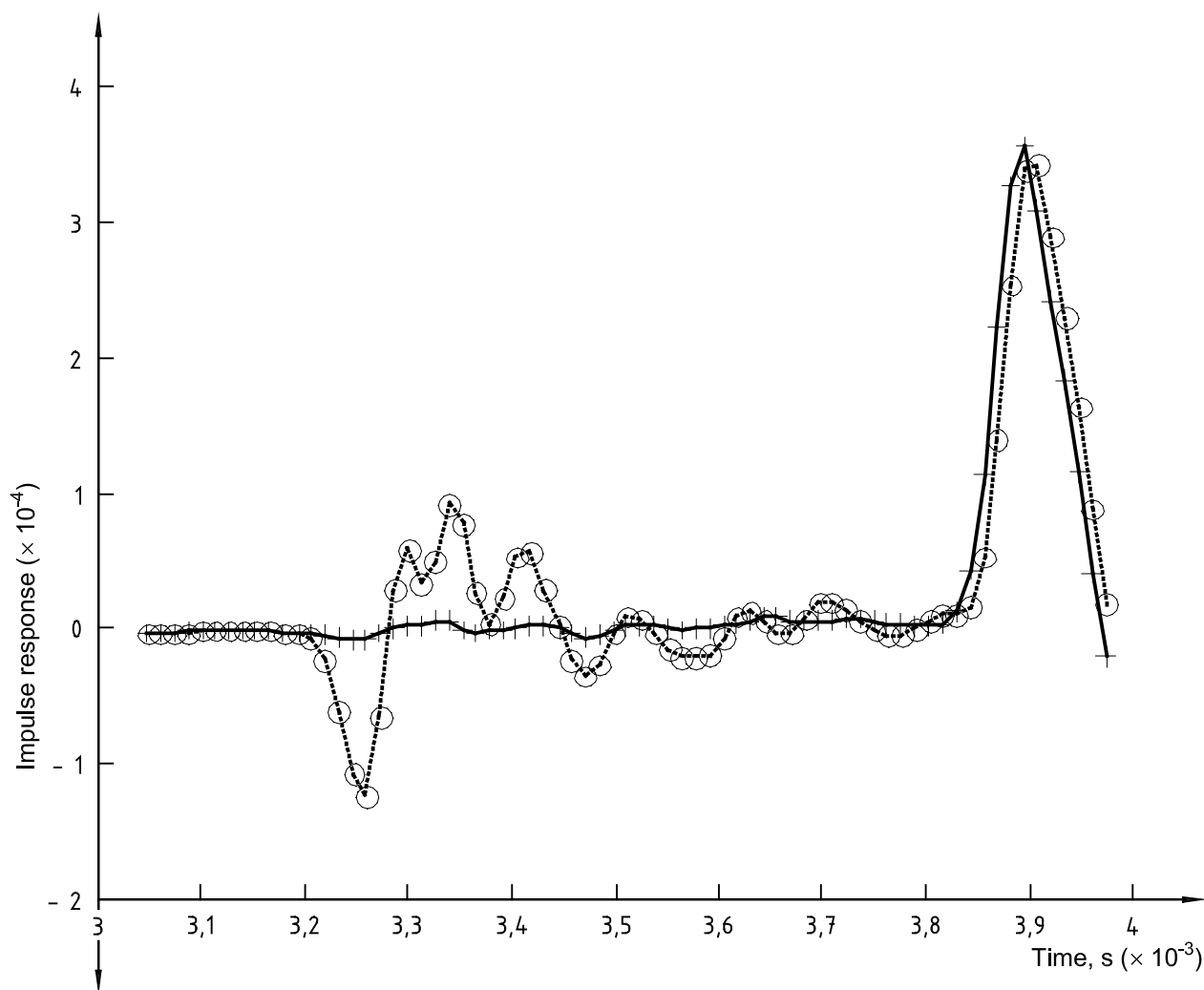

Figure G.1 — Example of a free-field measurement (circles) and of a reflected measurement (crosses) with a slight time shift between the two

It is necessary that before performing the subtraction, the free field-signal is corrected for this shift. Figure G.2 gives an example of the resulting signal with and without correction for time shift.



NOTE In this graph the correction is applied on the reflected signal.

Figure G.2 — Result of subtraction procedure without (circles) and with (crosses) time shift correction

Since in general the time shift will not be equal to a multiple of the sample size, step-wise shifting is inadequate.

The following procedure is recommended.

- a) Determine the time shift $\Delta\tau$. This can be done
 - from the graph of the impulse responses in free-field and in reflection conditions (if necessary zoom in on the edge of the direct component),
 - by cross-correlating both signals and detecting the time shift with maximal correlation, or
 - by detecting the minimal energy in the difference of both signals in an area around the direct component.

- b) Take the Fourier Transform of the free-field signal and change the phase of each coefficient by multiplying it by a frequency-dependent factor $\exp(i2\pi f\Delta\tau)$ with f the frequency of the corresponding Fourier coefficient (although the impulse response is an aperiodic function, most analysers will interpret it as a periodic signal and give Fourier series instead of a continuous function).
- c) From the resulting phase-corrected Fourier transform, the inverse transform is taken to generate the time-shifted direct signal, which then can be used for subtraction.

Bibliography

- [1] ISO 354, *Acoustics — Measurement of sound absorption in a reverberation room*
- [2] ISO 362, *Acoustics — Measurement of noise emitted by accelerating road vehicles — Engineering method*
- [3] ISO 7188, *Acoustics — Measurement of noise emitted by passenger cars under conditions representative of urban driving*
- [4] ISO 10844, *Acoustics — Specification of test tracks for the purpose of measuring noise emitted by road vehicles*
- [5] ISO 11819-1, *Acoustics — Measurement of the influence of road surfaces on traffic noise — Part 1: Statistical Pass-By method*
- [6] ISO 11819-2:—¹⁾, *Acoustics — Measurement of the influence of road surfaces on traffic noise — Part 2: Close-proximity method*
- [7] ISO 13473-1, *Characterization of pavement texture by use of surface profiles — Part 1: Determination of Mean Profile Depth*
- [8] AFNOR S 31-089:1990, *Code d'essai pour la détermination de caractéristiques acoustiques d'écrans installés en champ libre*
- [9] BERENGIER M. *An in-situ method to evaluate the absorption coefficient of road pavements*. Paper presented to ICA '95, Trondheim, 1995
- [10] BLEAKLEY C. and SCAIFE R. New formulas for predicting the accuracy of acoustical measurements made in noisy environments using the averaged m-sequence correlation technique. *J. Acoust. Soc. Am.*, **97** (2), 1995, pp. 1329-1332
- [11] BORISH J. and ANGELL J.B. An efficient algorithm for measuring the impulse response using pseudorandom noise. *J. Audio Engng. Soc.*, **31**, 1983, pp. 478-488
- [12] GARAI M. Measurement of the sound absorption coefficient in situ: the reflection method using periodic pseudorandom sequences of maximum-length. *Appl. Acoust.*, **39**, 1993, pp. 119-139
- [13] GARAI M., BERENGIER M., GUIDORZI P. and L'HERMITE P. Procedure for measuring the sound absorption of road surfaces in situ. *Proc. Euro-Noise '98*, Munich, 1998
- [14] MOMMERTZ E. Angle-dependent in-situ measurements of reflection coefficients using a subtraction technique. *Appl. Acoust.*, **46**, 1995, pp. 251-263
- [15] WILMS U. and HEINZ R. In-situ Messung komplexer Reflexionfaktoren von Wandflächen. *Acustica*, **75**, 1991, pp. 28-39

1) To be published.

BSI — British Standards Institution

BSI is the independent national body responsible for preparing British Standards. It presents the UK view on standards in Europe and at the international level. It is incorporated by Royal Charter.

Revisions

British Standards are updated by amendment or revision. Users of British Standards should make sure that they possess the latest amendments or editions.

It is the constant aim of BSI to improve the quality of our products and services. We would be grateful if anyone finding an inaccuracy or ambiguity while using this British Standard would inform the Secretary of the technical committee responsible, the identity of which can be found on the inside front cover.
Tel: +44 (0)20 8996 9000. Fax: +44 (0)20 8996 7400.

BSI offers members an individual updating service called PLUS which ensures that subscribers automatically receive the latest editions of standards.

Buying standards

Orders for all BSI, international and foreign standards publications should be addressed to Customer Services. Tel: +44 (0)20 8996 9001.
Fax: +44 (0)20 8996 7001. Email: orders@bsi-global.com. Standards are also available from the BSI website at <http://www.bsi-global.com>.

In response to orders for international standards, it is BSI policy to supply the BSI implementation of those that have been published as British Standards, unless otherwise requested.

Information on standards

BSI provides a wide range of information on national, European and international standards through its Library and its Technical Help to Exporters Service. Various BSI electronic information services are also available which give details on all its products and services. Contact the Information Centre.
Tel: +44 (0)20 8996 7111. Fax: +44 (0)20 8996 7048. Email: info@bsi-global.com.

Subscribing members of BSI are kept up to date with standards developments and receive substantial discounts on the purchase price of standards. For details of these and other benefits contact Membership Administration.
Tel: +44 (0)20 8996 7002. Fax: +44 (0)20 8996 7001.
Email: membership@bsi-global.com.

Information regarding online access to British Standards via British Standards Online can be found at <http://www.bsi-global.com/bsonline>.

Further information about BSI is available on the BSI website at <http://www.bsi-global.com>.

Copyright

Copyright subsists in all BSI publications. BSI also holds the copyright, in the UK, of the publications of the international standardization bodies. Except as permitted under the Copyright, Designs and Patents Act 1988 no extract may be reproduced, stored in a retrieval system or transmitted in any form or by any means – electronic, photocopying, recording or otherwise – without prior written permission from BSI.

This does not preclude the free use, in the course of implementing the standard, of necessary details such as symbols, and size, type or grade designations. If these details are to be used for any other purpose than implementation then the prior written permission of BSI must be obtained.

Details and advice can be obtained from the Copyright & Licensing Manager.
Tel: +44 (0)20 8996 7070. Fax: +44 (0)20 8996 7553.
Email: copyright@bsi-global.com.