

Industrial fans — Determination of fan sound power levels under standardized laboratory conditions —

Part 1: General overview

ICS 17.140.20; 23.120

National foreword

This British Standard is the UK implementation of ISO 13347-1:2004+A1:2010, incorporating corrigendum October 2006. It supersedes BS ISO 13347-1:2004, which is withdrawn.

The start and finish of text introduced or altered by amendment is indicated in the text by tags. Tags indicating changes to ISO text carry the number of the amendment. For example, text altered by ISO amendment 1 is indicated in the text by **A1** **A1** tags.

The UK participation in its preparation was entrusted to Technical Committee MCE/17, Industrial fans.

A list of organizations represented on this committee can be obtained on request to its secretary.

This publication does not purport to include all the necessary provisions of a contract. Users are responsible for its correct application.

Compliance with a British Standard cannot confer immunity from legal obligations.

Amendments/corrigenda issued since publication

| Amd. No. | Date | Comments |
|----------------------------|-----------------|--|
| 16791 Corrigendum No. 1 | 31 January 2007 | See national foreword |
| | 30 June 2011 | Implementation of ISO amendment 1:2010 |
| | | |
| | | |

This British Standard was published under the authority of the Standards Policy and Strategy Committee on 25 August 2004

© BSI 2011

ISBN 978 0 580 71837 3

INTERNATIONAL STANDARD

ISO 13347-1

First edition
2004-08-15

Industrial fans — Determination of fan sound power levels under standardized laboratory conditions —

Part 1: General overview

*Ventilateurs industriels — Détermination des niveaux de puissance
acoustique des ventilateurs dans des conditions de laboratoire
normalisées —*

Partie 1: Présentation générale



Reference number
ISO 13347-1:2004(E)

Contents

Page

| | |
|---|----|
| Foreword | iv |
| Introduction | v |
| 1 Scope..... | 1 |
| 2 Normative references | 1 |
| 3 Terms, definitions, symbols and units | 2 |
| 4 Limitations on use | 6 |
| 5 Measurement uncertainty..... | 7 |
| 6 Instrumentation | 8 |
| 7 Test methods..... | 9 |
| 8 Fan installation conditions..... | 10 |
| 9 Fan operating conditions | 12 |
| 10 Information to be recorded | 13 |
| 11 Calculations and evaluations..... | 16 |
| 12 Test report..... | 17 |
| Annex A (normative) Effect of rotational speed changes | 19 |
| Annex B (informative) Change of gas or air conditions | 20 |
| Annex C (normative) Corrections for end reflection | 21 |
| Annex D (informative) Simplified anechoic termination..... | 25 |
| Annex E (normative) Uncertainty analysis | 26 |
| Annex F (normative) Calibration of reference sound source | 31 |
| Annex G (informative) Filter weighted measurements | 33 |
| Bibliography | 34 |

Foreword

ISO (the International Organization for Standardization) is a worldwide federation of national standards bodies (ISO member bodies). The work of preparing International Standards is normally carried out through ISO technical committees. Each member body interested in a subject for which a technical committee has been established has the right to be represented on that committee. International organizations, governmental and non-governmental, in liaison with ISO, also take part in the work. ISO collaborates closely with the International Electrotechnical Commission (IEC) on all matters of electrotechnical standardization.

International Standards are drafted in accordance with the rules given in the ISO/IEC Directives, Part 2.

The main task of technical committees is to prepare International Standards. Draft International Standards adopted by the technical committees are circulated to the member bodies for voting. Publication as an International Standard requires approval by at least 75 % of the member bodies casting a vote.

Attention is drawn to the possibility that some of the elements of this document may be the subject of patent rights. ISO shall not be held responsible for identifying any or all such patent rights.

ISO 13347-1 was prepared by Technical Committee ISO/TC 117, *Industrial fans*.

ISO 13347 consists of the following parts, under the general title *Industrial fans — Determination of fan sound power levels under standardized laboratory conditions*:

- *Part 1: General overview*
- *Part 2: Reverberant room method*
- *Part 3: Enveloping surface methods*
- *Part 4: Sound intensity method*

Introduction

The need for this new International Standard, ISO 13347, has been evident for some time. Whilst a number of national standards exist for the measurement of fan noise, none has received universal acceptance nor may comparisons be readily made.

Forming part of the ISO/TC 117 series of fan standards, this part of ISO 13347 deals with the determination of the fan sound power level appropriate to a particular application. In describing the test and rating procedures, numerous references are made to ISO 5801 as well as to other relevant ISO standards. This general overview should be read in conjunction with the appropriate part of ISO 13347 that specifies, in detail, methods for determining the sound power propagated from a fan in specified installation conditions as a function of frequency.

This part of ISO 13347 primarily deals with the determination of sound power levels of industrial fans used in four types of installations (see Clause 4) for ducted applications.

The test procedures described in this part of ISO 13347 relate to laboratory conditions. The measurement of performance under site conditions is not included. Acoustic system effects can be considerable where the airflow into and out of the fan is not free from swirl, nor fully developed.

This part of ISO 13347 describes methods for determining sound power levels of fans in one-third octave bandwidths and one octave bandwidths.

Data obtained in accordance with this part of ISO 13347 may be used for the following purposes amongst others:

- a) comparison of fans which are similar in size and type;
- b) comparison of fans which are different in size, type, design, speed, etc;
- c) determining whether a fan is suitable for a specified upper limit of sound emission;
- d) scaling of fan noise from one size and speed to another size and speed of the same type of fan;
- e) prediction of sound pressure level in application of the fan;
- f) engineering work to assist in developing machinery and equipment with lower sound emissions.

Industrial fans — Determination of fan sound power levels under standardized laboratory conditions —

Part 1: General overview

1 Scope

This part of ISO 13347 deals with the determination of the acoustic performance of industrial fans. In addition, it may be used to determine the acoustic performance of fans combined with an ancillary device such as a roof cowl or damper or, where the fan is fitted with a silencer, the sound power resulting from the fan and silencer combination.

2 Normative references

The following referenced documents are indispensable for the application of this document. For dated references, only the edition cited applies. For undated references, the latest edition of the referenced document (including any amendments) applies.

ISO 266, *Acoustics — Preferred frequencies*

ISO 1000, *SI units and recommendations for the use of their multiples and of certain other units*

ISO 3741, *Acoustics — Determination of sound power levels of noise sources using sound pressure — Precision methods for reverberation rooms*

ISO 3743-1, *Acoustics — Determination of sound power levels of noise sources — Engineering methods for small, movable sources in reverberant fields — Part 1: Comparison method for hard-walled test rooms*

ISO 3743-2, *Acoustics — Determination of sound power levels of noise sources using sound pressure — Engineering methods for small, movable sources in reverberant fields — Part 2: Methods for special reverberation test rooms*

ISO 3744:1994, *Acoustics — Determination of sound power levels of noise sources using sound pressure — Engineering method in an essentially free field over a reflecting plane*

ISO 3745, *Acoustics — Determination of sound power levels of noise sources using sound pressure — Precision methods for anechoic and semi-anechoic rooms*

ISO 5136:2003, *Acoustics — Determination of sound power radiated into a duct by fans and other air-moving devices — In-duct method*

ISO 5801, *Industrial fans — Performance testing using standardized airways*

ISO 6926:1999, *Acoustics — Requirements for the performance and calibration of reference sound sources for the determination of sound power levels*

ISO 9614-1, *Acoustics — Determination of sound power levels of noise sources using sound intensity — Part 1: Measurement at discrete points*

ISO 10302, *Acoustics — Method for the measurement of airborne noise emitted by small air-moving devices*

ISO 13347-2:2004, *Industrial fans — Determination of fan sound power levels under standardized laboratory conditions — Part 2: Reverberant room method*

ISO 13347-3:2004, *Industrial fans — Determination of fan sound power levels under standardized laboratory conditions — Part 3: Enveloping surface methods*

ISO 13347-4:2004, *Industrial fans — Determination of fan sound power levels under standardized laboratory conditions — Part 4: Sound intensity method*

ISO 13349, *Industrial fans — Vocabulary and definitions of categories*

ISO 13350:1999, *Industrial fans — Performance testing of jet fans*

3 Terms, definitions, symbols and units

3.1 Terms and definitions

For the purposes of this document, the non-acoustical terms and units defined in ISO 5801, ISO 13349 and ISO 1000, apply; the following acoustical definitions apply, they are taken from ISO 3470 to 3747 wherever possible and some have been expanded to fit the specific needs of this document.

3.1.1

inlet sound power level

sound power level of a fan determined at the fan inlet in a specified test installation type, A, B, C or D

3.1.2

outlet sound power level

sound power level of a fan determined at the fan outlet in a specified test installation, type A, B, C or D

3.1.3

casing sound power level

sound power level radiated from a fan casing

NOTE 1 If the fan drive is external to the fan casing, the casing sound power shall include the sound power generated by and radiated from the fan drive

NOTE 2 When cataloguing a range of fans, it is not always possible to include the motor noise, as this will vary according to the power and type of motor selected. Motor noise may then be omitted, provided this fact is clearly stated.

3.1.4

frequency range of interest

frequency range including octave bands with centre frequencies between 63 Hz and 8 000 Hz and one-third octave bands with centre frequencies between 50 Hz and 10 000 Hz

NOTE For special purposes, the frequency range may be extended at either end, provided that the test environment and instrument accuracy are satisfactory for use over the extended frequency range. For fans which radiate sound at predominantly high (or low) frequency, the frequency range of interest may be limited in order to optimise the test facility and procedures.

3.1.5

blade passage frequency

BPF

frequency of fan impeller blades passing a single fixed object

NOTE The blade passage frequency is calculated by the following formula

$$\text{BPF} = \frac{x \times n}{60} \text{ Hz}$$

where

x is the number of blades;

n is the fan speed, expressed in revolutions per minute.

3.1.6

chamber

enclosure used to regulate flow and absorb sound; it may also conform to air test chamber conditions outlined in ISO 5801

3.1.7

ducted fan

fan having a duct connected to either its inlet or outlet, or both

3.1.8

fan inlet area

A_1

surface plane bounded by the upstream extremity of the air-moving device

NOTE The inlet area is, by convention, taken as the gross area in the inlet plane inside the casing.

3.1.9

fan outlet area

A_2

surface plane bounded by the downstream extremity of the air-moving device

NOTE The fan outlet area is, by convention, taken as the gross area in the outlet plane inside the casing.

3.1.10

end reflection

phenomenon which occurs whenever sound is transmitted across an abrupt change in area such as at the end of a duct in a room

NOTE When end reflection occurs, some of the sound is reflected back into the duct and does not escape into the room.

3.1.11

non-ducted fan

fan without a duct connected to either its inlet or outlet

3.1.12

reverberant room

enclosure meeting the requirements of Annex A and/or Annex B of ISO 13347-2:2004

3.1.13

reference point of fan equipment

position that is used to define and locate the measurement surface relative to the fan equipment under test, see Figures 1 to 4 of ISO 13347-3:2004

NOTE 1 Generally, the reference point is the centroid of the centres of all inlets and outlets that contribute to the sound power level being determined.

NOTE 2 For total sound power testing of fan equipment with a single inlet and a single outlet, the reference point is the midpoint of the line that joins the centres of the inlet and the outlet.

NOTE 3 For fan inlet (or outlet) sound power testing of equipment with a single inlet (or single outlet), the reference point is the centre of that inlet (or outlet)

**3.1.14
 standard air**

air with a density of 1,2 kg/m³

NOTE 1 Standard air has a ratio of specific heats of 1,4 and a viscosity of 1,815 E-03 Pa.s.

NOTE 2 Air at 16 °C dry bulb temperature, 50 % relative humidity and 100 kPa barometric pressure has these properties, but this is not part of the definition.

NOTE 3 Air at 20 °C dry bulb temperature, 50 % relative humidity and 101.325 kPa barometric pressure also has these properties but this is not a part of the definition.

3.2 Fan sound power levels

Considering all possible combinations for installation conditions specified in Clause 4, twelve different sound power level (L_W) descriptions are defined in Table 1, for example $L_W(A,in)$.

Table 1 — Sound power levels

| Number | Suffix | Description |
|--------|-------------|---|
| 1 | (A,in) | free-inlet sound power level, type A installation. |
| 2 | (A,out) | free-outlet sound power level; type A installation. |
| 3 | (A,tot) | total sound power level of a fan type A installation (includes the contributions from the inlet, outlet, fan casing and drive). |
| 4 | (B,in) | free-inlet sound power level; type B installation. |
| 5 | (B,in+cas) | free-inlet sound power level plus casing-radiated noise; type B installation. |
| 6 | (B,out) | ducted outlet sound power level; type B installation. |
| 7 | (C,in) | ducted inlet sound power level; type C installation. |
| 8 | (C,out) | free-outlet sound power level; type C installation |
| 9 | (C,out+cas) | free-outlet sound power level plus casing-radiated noise; type C installation |
| 10 | (D,in) | ducted inlet sound power level; type D installation. |
| 11 | (D,out) | ducted outlet sound power level; type D installation. |
| 12 | (D,cas) | casing-radiated sound power level; type D installation. |

NOTE 1 All of these symbols may be used to indicate levels in one-third octave or octave frequency bands as well as overall sound power levels and A-weighted sound power levels, provided that the sound power to which the symbols relate is clearly defined.

Where noise from the drive may contribute to the noise radiated from a casing then this should be clearly stated by the addition of +dr e.g., $L_W(D,cas + dr)$.

NOTE 2 Not all of the above levels need to be measured for a particular fan.

3.3 Other symbols

For consistency and mutual understanding, it is recommended that the symbols and units shown in Table 2 be used in reporting and calculation. Unless otherwise noted, the subscript number refers to the mid-frequency of the octave band or one-third octave band number.

Table 2 — Symbols, units

| Symbol | Term | SI unit |
|-----------------------------|--|-------------------------|
| A_1 | fan inlet area | m ² |
| A_2 | fan outlet area | m ² |
| c | speed of sound | m/s |
| D_r | distance between reference box and rectangular measurement surface | m |
| D_o | characteristic acoustic source dimension | m |
| D_N | nominal diameter of bellmouth/opening in reflecting plane | m |
| D_{\min} | minimum distance between equipment under test and reverberant room measurement surface | m |
| d | duct diameter | m |
| d_e | equivalent diameter (of rectangular duct) | m |
| E_o | duct outlet end correction | dB |
| E_i | duct inlet end correction | dB |
| E_W | adjustment to sound power level for duct end correction(s) | dB |
| f | frequency | Hz |
| h | height of centre of orifice above floor level, or above another reflection plane | m |
| I | sound intensity | W/m ² |
| \bar{I} | surface average sound intensity | W/m ² |
| I_n | sound intensity I at measurement location n | W/m ² |
| I_{ref} | reference intensity, 1 pW/m ² (1×10^{-12} W/m ²) | — |
| l_c | measurement surface characteristic dimension (length) | m |
| $\boxed{\text{AC}_1}$ I_s | measurement surface ratio | — $\boxed{\text{AC}_1}$ |
| K_1 | background-noise correction | dB |
| K_2 | environmental noise correction | dB |
| l | dimensions of the reference box | m |
| L_i | sound intensity level (re. 1 pW/m ²) | dB |
| \bar{L}_i | surface average sound intensity level | dB |
| L_{if} | fan sound intensity level | dB |
| \bar{L}_{if} | surface average fan sound intensity level | dB |
| L_{iq} | RSS sound intensity level | dB |
| \bar{L}_{iq} | surface average RSS sound intensity level | dB |
| L_p | sound pressure level, re 20 μ Pa (2×10^{-5} Pa) | dB |
| L_{pc} | corrected sound pressure level of the fan | dB |
| L_{pb} | recorded sound pressure level of room background as measured over the normal microphone path | dB |
| \bar{L}_{pb} | background sound pressure level | dB |
| L_{pbn} | L_{pb} at measurement location n | dB |
| $L_{W\text{rq}}$ | RSS calibration sound power level | dB |
| L_{pm} | recorded sound pressure level of fan and room background as measured over the normal microphone path | dB |
| L_{pq} | corrected sound pressure level of the RSS | dB |
| L_{pqm} | recorded sound pressure level of the RSS and room background as measured over the normal microphone path | dB |

Table 2 (continued)

| Symbol | Term | SI unit |
|---------------|--|----------------|
| L_W | sound power level, re 1 pW (1×10^{-12} W) | dB |
| L_{Wr} | sound power level of RSS | dB |
| λ | wavelength | m |
| M | Mach number | Dimensionless |
| p | sound pressure | Pa |
| p_{ref} | reference sound pressure, 20 μ Pa (2×10^{-5} Pa) | — |
| p_s | fan static pressure | Pa |
| p_t | fan (total) pressure | Pa |
| r | radius of spherical (hemispherical) measurement surface | m |
| r_d | duct area/Orifice area | Dimensionless |
| s | standard deviation | dB |
| θ | air temperature | K |
| S | measurement surface area | m ² |
| S_H | cross-sectional area of a section through the fan in the measurement surface plane | m ² |
| S_s | portion of measurement surface in contact with discharge flow for fans with outlet orifice | m ² |
| W | sound power | W |
| W_{ref} | reference sound power, 1 pW (1×10^{-12} W) | dB |
| z | measurement surface characteristic dimension (height above reflecting plane) | m |
| δ_{Wn} | convergence index (with n measurement locations) | dB |

4 Limitations on use

For low-power fans (up to 3 kW) that could be run from a domestic power supply (single phase AC at a voltage not exceeding 250 V and a current not exceeding 16 A), reference should be made to IEC 60704-2-7 which covers household and similar fans.

For in-duct tests, the test duct diameter range as specified in ISO 5136 is from 0,15 m to 2 m (for more details see 6.5).

For reverberant room tests, the size of fan is limited to less than 2 % of the room volume.

There are no restrictions on the size of fan which may be tested by enveloping surface and sound intensity methods, provided the test environment meets the specified acoustic requirements. A test procedure is specified in Clause 9 of ISO 13350:1999 for testing jet fans.

The test procedures specified in this part of ISO 13347 are intended principally for tests conducted using standardized test configurations and under specified environments and conditions and may not be appropriate to site test conditions.

The fan installation conditions conform to the four categories of installation types specified in ISO 5801:

- type A: free inlet, free outlet;
- type B: free inlet, ducted outlet;
- type C: ducted inlet, free outlet;
- type D: ducted inlet, ducted outlet.

5 Measurement uncertainty

Measurements made in conformance with this part of ISO 13347 tend to result in standard deviations which are equal to or less than those given in Table 3. These standard deviations take into account the cumulative effects of all causes of measurement uncertainty, such as source location, duct end reflections, duct transitions, instrument calibration, derivation of sound power from sound pressure and sampling. They do not reflect variations in the sound power radiated by the fan itself due, for example, to changes in installation conditions or manufacturing tolerances. For further information refer to Annex C.

Reverberant field tests have, for many years, been carried out without the addition of anechoic terminations on the non-measured side of the fan. This part of ISO 13347 allows for tests to be performed both with and without such terminations, but it must be recognised that the results will be different. It shall be clearly stated, in all documentation, test reports, catalogues, etc., whether or not anechoic terminations were fitted.

Table 3 — Uncertainty in determination of the frequency-band sound power levels

| One-third octave band frequencies Hz | Standard deviation, dB | | | | |
|---|------------------------------------|--|-------------------------------|---|--|
| | In-duct (see also ISO 5136) | Reverberant field (see also ISO 3743-2) | | Enveloping surface methods (see also ISO 3744) | Sound intensity field (see also ISO 9614-1) |
| | | with anechoic terminations | without anechoic terminations | | |
| 50 | 3,5 | | | 5,0 | 3,0 |
| 63 | 3,0 | *5,0 | 6,0 | 5,0 | 3,0 |
| 80 | 2,5 | | | 5,0 | 3,0 |
| 100 | 2,5 | | | 3,0 | 3,0 |
| 125 | 2,0 | 5,0 | 3,0 | 3,0 | 3,0 |
| 160 | 2,0 | | | 3,0 | 3,0 |
| 200 | 2,0 | | | 2,0 | 2,0 |
| 250 | 2,0 | 3,0 | 3,0 | 2,0 | 2,0 |
| 315 | 2,0 | | | 2,0 | 2,0 |
| 400 | 2,0 | | | 1,5 | 2,0 |
| 500 | 2,0 | 2,0 | 3,0 | 1,5 | 2,0 |
| 630 | 2,0 | | | 1,5 | 2,0 |
| 800 | 2,0 | | | 1,5 | 1,5 |
| 1000 | 2,0 | 2,0 | 3,0 | 1,5 | 1,5 |
| 1250 | 2,0 | | | 1,5 | 1,5 |
| 1600 | 2,0 | | | 1,5 | 1,5 |
| 2000 | 2,0 | 2,0 | 3,0 | 1,5 | 1,5 |
| 2500 | 2,0 | | | 1,5 | 1,5 |
| 3150 | 2,0 | | | 1,5 | 1,5 |
| 4000 | 2,0 | 2,0 | 3,0 | 1,5 | 1,5 |
| 5000 | 2,5 | | | 1,5 | 1,5 |
| 6300 | 3,0 | | | 2,5 | 2,5 |
| 8000 | 3,5 | 3,0 | 3,0 | 2,5 | 2,5 |
| 10000 | 4,0 | | | 2,5 | *3,0 |

NOTE 1 For the in-duct method, the measurement uncertainty may be reduced by careful design of the test rig to eliminate transition ducts and by use of more absorptive terminating ducts.

As noted at the beginning of this clause, the uncertainties given in Table 3 do not allow for the variations in sound power levels due to manufacturing tolerances. There are consequent differences between one fan and another of the same nominal design, rotational speed, position on its performance characteristic, etc. In any specifications, which are part of a contract, it is necessary to apply tolerances to sound values. These may be calculated for a normal distribution of data by multiplying the quoted standard deviations by 2 to obtain 95 % confidence limits. A further deviation should also be added to account for manufacturing tolerances, as described in ISO 13348.

NOTE 2 When octave-band data are calculated, the uncertainty of each octave band level will not be greater than the largest uncertainty of the three constituent one-third octave bands.

NOTE 3 Only octave bands are shown for the reverberant method in accordance with ISO 3743.

A1 Figures marked with "*" in Table 3 have only been added to ISO 3740:2000. For general purposes therefore, many existing rigs are designed to operate at a cut-off frequency of 100 Hz thus giving the octave bands of interest as those between 125 Hz and 8 000 Hz.

Many centrifugal fans have significant quantities of noise in the 63 Hz octave band and, for special purposes, it is permissible to extend the measurements to this band, provided the test environment and instrument accuracy are satisfactory over this extended range.

The uncertainty given for these low frequencies can only be achieved by exercising extreme care, and wherever possible, results should be restricted to octave bands of 125 Hz and above.

NOTE 4 Where the reverberant room is in full conformity with ISO 3743-1 (hard-walled test room) then the uncertainty may be reduced.

NOTE 5 According to impedance theory, the sound power in the discharge duct from a fan is a function not only of the outlet duct length and terminating load but also of the inlet duct length and terminating load. In a similar way, the inlet sound power is a function not only of the inlet duct length and terminating load but also of the outlet duct length and terminating load.

NOTE 6 If the fan internal impedance is high, this has the effect of damping the variations in sound power along a duct. The length of the ducts and terminal loadings therefore become somewhat less critical.

NOTE 7 In a real fan installation, therefore, the sound power levels are likely to differ from those obtained from tests without anechoic terminations. The differences will be greatest at very low frequencies. For further information, refer to the relevant references in the bibliography.

NOTE 8 Sound power levels obtained by using the methods described in Table 3 are for a fully developed flow into the fan, without pre-swirl, and straight-line flow out of the fan without swirl. Any disturbance up-stream or down-stream, therefore, will increase the levels in a real installation.

NOTE 9 The figures given in column 4 of Table 3 are taken from AMCA Standard 300-96. They are very much dependent on duct lengths and diameters, especially in the first and second octave bands. **A1**

The standard deviations in Table 3 are equivalent to those obtained from the engineering methods described in ISO 3743, ISO 3744, ISO 5136 and ISO 9614-1 as appropriate. They are those which would result from a set of measurements which were undertaken on a single fan in a large number of different laboratories and include the cumulative effects of all causes of measurement uncertainty.

The repeatability of measurements in any one laboratory may be considerably better than the values in Table 3 would indicate.

6 Instrumentation

6.1 General

Depending on the test method, the instrumentation shall be as specified in this part of ISO 13347, together with ISO 3741, ISO 3743, ISO 3744, ISO 5136, ISO 9614-1 and ISO 13350.

Instrumentation shall be so designed as to determine the mean-square value of the sound pressure in octave and/or one-third octave bands averaged over time and space.

6.1.1 Microphone

A microphone of a standardized sound level meter shall be used. If a sampling tube is used, the dimensions of the microphone shall be compatible with it. The correction C_1 for frequency response shall be supplied by the instrument manufacturer.

6.1.2 Microphone cable

The microphone/cable system shall be such that the sensitivity does not change with temperature in the range encountered in the test. Cable flexing due to either microphone traversing or airflow across the cable should not introduce cable noise which interferes with the measurements.

6.1.3 Sound level meter or other microphone amplifier

The sound level meter or other amplifier used to amplify the microphone signal shall comply with the electrical requirements for sound level meters. The flat response shall be used.

6.2 Frequency analyser

The frequency analyser shall have the capacity of frequency analysing into one-third octave bandwidths in accordance with ISO 266.

6.3 Turbulence screens and windshields

6.3.1 Windshields

A microphone exposed to excessive air velocity will give a falsely high reading. This may be rectified by fitting the microphone with a sampling tube, a nose cone or a foam ball.

If the air velocity of the microphone is greater than 1 m/s, a sampling tube, nose cone or foam ball must be used.

6.3.2 Sampling tube

The turbulence screen or sampling tube is a tubular windshield with a longitudinal slit backed by a porous material and is attached to the microphone. Its purpose is to reduce the response of the microphone to the turbulent fluctuations of air pressure within the test duct.

6.3.3 Wind-generated false noise

The flow of an airstream over a microphone fitted with a sampling tube, nose cone or foam ball will still generate an apparent change in sound pressure level at the microphone, even though it is reduced when compared to an unshielded microphone. This change is not attributable to the fan, but is a function of microphone design. For further information refer to ISO 5136.

6.4 Reference sound source (RSS)

A calibrated RSS shall conform to the requirements of Annex F.

7 Test methods

7.1 General

The test method shall be selected according to the sound power level which is to be determined and the size of the fan.

If a fan has a duct on the inlet and/or outlet side, then the sound power levels on the sides which are ducted should be determined by an in-duct method as detailed in ISO 5136. As an alternative method with a lower order of accuracy, an enveloping surface, sound intensity or reverberant room method may be used with corrections added for the effect of duct end reflection. Where figures are obtained in such an alternative method (e.g. for small duct sizes or for other reasons) then this shall be clearly stated.

If the fan is unducted on the inlet and/or outlet side, then the sound power levels on the sides which are unducted shall be determined by a method where the sound pressures are measured by either an enveloping surface method, a sound intensity method or a reverberation room method.

7.2 Special considerations

For small unducted fans of the type used to cool electronic appliances, the determination of $L_W(A, \text{tot})$ may be undertaken using the method described in ISO 10302.

For ceiling and table fans, the determination of $L_W(A, \text{tot})$ should be undertaken by the method specified in IEC 60704-2-7.

For jet fans, the determination of $L_W(A, \text{tot})$ should be undertaken using the method described in Clause 9 of ISO 13350:1999.

For the determination of $L_W(A, \text{in})$, $L_W(A, \text{out})$, $L_W(A, \text{tot})$, $L_W(B, \text{in} + \text{cas})$, $L_W(C, \text{out})$, $L_W(C, \text{out} + \text{cas})$ and $L_W(D, \text{cas})$, either the method requiring a free field over a reflecting plane specified in ISO 3744 or ISO 3745 may be used, or the method requiring a reverberation room as specified in ISO 13347-2 may be used, provided that certain criteria regarding the uniformity of the sound field within the room are satisfied.

For the determination of $L_W(B, \text{out})$, $L_W(C, \text{in})$, $L_W(D, \text{in})$ and $L_W(D, \text{out})$, the test method should be as described in ISO 5136.

8 Fan installation conditions

8.1 Introduction

The measurement procedures specified in this part of ISO 13347 cover the following fan installations (see Clause 4):

- free inlet/free outlet (type A);
- free inlet/ducted outlet (type B);
- ducted inlet/free outlet (type C);
- ducted inlet/ducted outlet (type D).

In general, the sound powers radiated from the fan inlet into free space and into a duct are different, and each is affected by what is connected to the outlet of the fan characterised by the acoustical load impedance. Similarly, the sound powers radiated from the fan outlet into free space and into a duct are different and depend on the installation condition (acoustical load impedance) on the fan inlet side.

To specify a standardized acoustical load impedance for ducted installations, all ducts less than 1 600 mm in diameter and connected to the test fan have to be terminated anechoically. A duct in which the sound pressure is to be measured for determination of the in-duct sound power according to ISO 5136 is called "test duct". Ducts which are used only to provide the standardized acoustic loading, i.e. in which no sound measurements are to be made, are called "terminating ducts". The maximum permissible pressure reflection coefficients for test ducts and for terminating ducts as specified in ISO 5136 are given in Table 4.

NOTE See also ISO 7235 and ISO 13347-2, for the specification of transmission elements.

It is, of course, not necessary to measure all of the quantities for each test fan, but only the sound power levels required for a particular application.

To determine the sound power radiated from the fan inlet or outlet into a duct (in-duct sound power level), i.e. 6, 7, 10 and 11 in Table 1, the in-duct method in ISO 5136 should be used.

For all other quantities, either the reverberant field-test methods described in 8.2, the enveloping surface methods described in 8.3 or the sound intensity method described in 8.4 shall be applied.

If the cross-sectional area of the fan inlet or outlet is larger than 2 m² (this corresponds to a circular area of 1,6 m in diameter), alternative use of the in-duct method, reverberant field method, enveloping surface and sound intensity method is permitted to determine the in-duct sound power or free-space sound power level. This is based on the assumption that, for such large dimensions, the sound powers radiated into a duct and into free space are equal.

Table 4 — Maximum permissible values for the pressure reflection coefficient of anechoic duct terminations

| One-third octave band centre frequency Hz | Maximum pressure reflection coefficient | |
|--|---|------------------|
| | Test duct | Terminating duct |
| 50 | 0,4 | 0,8 |
| 63 | 0,35 | 0,7 |
| 80 | 0,3 | 0,6 |
| 100 | 0,25 | 0,5 |
| 125 | 0,15 | 0,3 |
| 160 | 0,15 | 0,3 |
| > 160 | 0,15 | 0,2 |

NOTE See Annex D for information concerning the use of simplified anechoic terminations for terminating ducts.

8.2 Reverberant room test method

A test using this method shall be conducted in accordance with ISO 13347-2.

NOTE Where the room complies with the requirements of ISO 3741, then the method specified in that standard may also be used.

8.3 Enveloping surface test method

The enveloping surface test method may be used to determine the open inlet, open outlet or casing breakout sound power. The methods shall be strictly in accordance with ISO 13347-3.

8.4 Sound intensity method

Tests using this method shall be strictly in accordance with ISO 13347-4.

8.5 In-duct test method

The test airways, comprising an intermediate duct, test duct and terminating duct shall be as described in ISO 5136. The test duct diameter range is from 0,15 m to 2 m. This implies that the range of equivalent diameters of fan inlets which can be tested using the in-duct procedure is from 0,104 m to 2,000 m, and the range of equivalent diameters of fan outlets is from 0,104 m to 2,390 m.

For test ducts in the diameter range $0,070 \text{ m} \leq d < 0,15 \text{ m}$, the test method described in Annex H of ISO 5136:2003 shall be used, which allows testing of fans with inlet and outlet equivalent diameters down to 0,0485 m.

For test ducts in the diameter range $2\text{ m} < d \leq 7,1\text{ m}$, the test method described in Annex J of ISO 5136:2003 shall be used, which allows testing of fans with inlet equivalent diameters of up to 7,1 m and outlet equivalent diameters of up to 8,5 m.

In cases where the fan drive is within the fan casing (e.g. electric motor within the airway or belt and pulley within the airway), the in-duct noise will be partly fan generated and partly due to the drive and transmission. No allowance may be made for any contribution of noise from the drive or transmission, and the sound pressure levels measured within the duct shall be taken as the noise of the fan.

8.6 Limitations

These methods shall not be used for site tests unless agreed to by all the parties concerned.

8.7 Small fans

The in-duct, enveloping surface, reverberant room and sound intensity test methods all have disadvantages when measuring the sound power level of very small fans, as are typically used in the computer and business equipment industries as defined in ISO 10302. These disadvantages are also evident in other industries which use small fans. For this reason, a method using a plastic plenum box has been included as an acceptable method and is detailed in ISO 10302.

9 Fan operating conditions

9.1 General

The noise generated by a fan is related to its operating conditions, i.e. its rotational speed, fan pressure and airflow rate. It is important that the aerodynamic duty is known when acoustic measurements are being made. Care is required to ensure that methods of determining or controlling the aerodynamic performance do not affect the noise generated by the fan or interfere with the acoustical measurements.

9.2 Measurement of ambient conditions

The ambient air conditions of temperature, pressure and humidity shall be within the limits specified in the appropriate standards ISO 3743, ISO 3744, ISO 3745, ISO 5136 and ISO 9614-1.

9.3 Fan rotational speed

The fan rotational speed shall be measured and held steady (within 1 % change) during the sound test for any one characteristic point on the fan. The fan rotational speed during the test shall be within 5 % of the specified rotational speed to minimise the change in fan sound power when applying the conversion rules.

When it is not possible to test a fan within these limits, an indirect test at a different speed is permitted providing that the test is reported at the test speed and then scaled to the specified or nominal speed (see Annex A).

The procedures for scaling the sound data from the test speed to the specified speed shall be agreed between the interested parties in advance of the tests being undertaken.

9.4 Determination of fan aerodynamic operating point

The identification of the operating point on the fan aerodynamic characteristic shall preferably be by measurement of the mass flowrate using one of the methods specified in ISO 5801. The flowrate at the operating point may be inferred, indirectly, by a determination of static pressure. The uncertainty of flowrate determination shall not exceed 5 %.

9.5 Control of fan operating condition

A throttling device shall be used to control the operating point on the fan characteristic. In the case of a type B configuration, the throttle should, preferably, be located at the outlet end of the anechoic termination on the downstream side. In the case of a type C configuration, a throttle may be incorporated at the upstream end of the anechoic termination.

The sound level in the test environment, generated by the throttling device and the flow measurement system, shall be at least 10 dB below the measured sound level from the fan under test. The anechoic termination shall be designed with sufficient silencing capacity in all one-third octave bands of interest to secure this criterion.

With a type A configuration, the throttle arrangement needs to be arranged integrally with the test chamber. A similar arrangement may be used for type B, type C and type D configurations.

10 Information to be recorded

10.1 General

Information given in 10.2 to 10.9, when applicable, shall be compiled and recorded for all measurements made in accordance with this part of ISO 13347.

10.2 Fan under test

10.2.1 Description of the fan under test

- a) Manufacturer.
- b) Model.
- c) Nominal size.
- d) Impeller diameter.
- e) Number of blades.
- f) Blade setting (adjustable or variable pitch fans only).
- g) Number of stator vanes (as applicable).
- h) Inlet area and dimensions.
- i) Outlet area and dimensions.

10.2.2 Operating conditions

- a) Fan speed.
- b) Fan airflow rate.
- c) Fan pressure or fan static pressure at actual test conditions.
- d) Air density.

10.2.3 Mounting conditions

- a) Test figure.
- b) Test installation category, e.g. A, B, C or D (see ISO 5801).
- c) Sketch showing laboratory set-up, including location of any equipment and acoustical measurements.

10.3 Acoustic environment

10.3.1 Description of the test environment: if indoors, description of the physical treatment of walls, ceiling and floor; sketch showing the location of the source and room contents; if outdoors, sketch showing the location of the source with respect to the surrounding terrain, including a physical description of the test environment.

10.3.2 Acoustical qualification of the test environment.

10.3.3 Test data

- a) Barometric pressure.
- b) Ambient dry-bulb temperature.
- c) Ambient wet-bulb temperature.
- d) Dry-bulb temperature at the fan inlet.
- e) Static pressure at the fan inlet.
- f) Wind speed and direction relative to the test installation, if outdoors.

10.3.4 Laboratory and instrumentation

- a) Laboratory name.
- b) Laboratory location.
- c) Technician's name.
- d) List of equipment used for the measurements including name, type, serial Nos. and manufacturer with dates of calibration.
- e) Bandwidth of frequency analyser.
- f) Scope of room qualification. Data shall indicate if the test room is qualified for full or one-third octaves, and in the case of pure tone testing, the one-third octaves bands for which the qualification applies.
- g) Frequency response of the instrumentation system.
- h) Method used for calibration of the microphones and other system components; the date and place of calibration shall be given.
- i) Characteristics of windshield (if used).
- j) Reference sound source (type and serial number).

10.3.5 Location of fan in the test environment or the description of the ducts used, including lengths and cross-sectional areas (or diameters) and the description of the anechoic termination(s).

10.3.6 If a test fan has additional noise sources, a description of the source(s) in operation during the measurements (e.g. type of drive, size of motor, etc.).

10.4 Acoustic data appropriate to the method of test

10.4.1 The shape of the measurement surface, the measurement distance, the location and orientation of microphone positions or paths.

10.4.2 The area, S , of the measurement surface.

10.4.3 The corrections (in dB), if any, applied in each one-third octave band for the frequency response of the microphone, frequency response of the filter in the pass band, background noise, etc.

10.4.4 Corrections C_1 , C_2 and $C_{3,4}$ according to ISO 5136.

10.4.5 The background correction K_1 and environmental correction, K_2 , calculated according to the procedures of ISO 3744.

10.4.6 Microphone positions.

10.4.7 The mean sound pressure level, L_p (in dB, reference 20 μ Pa), in each one-third octave frequency band of interest.

10.4.8 The sound power level, L_W (in dB, reference 1 pW) for all frequency bands used.

10.4.9 The sound power level, L_W (in dB, reference 1 pW) for all frequency bands used, corrected from test speed to specified speed in accordance with Annex A.

10.4.10 Remarks on the subjective impression of the noise (audible discrete tones, impulsive character, spectral content, temporal characteristics, etc.).

10.4.11 Remarks on the contributions of drive and transmission noise to the total noise.

10.4.12 The date and time when the measurements were performed.

10.4.13 The names of the test personnel.

10.4.14 Measurements taken relating to the environment.

- a) Background sound pressure level;
- b) Sound pressure level of the reference sound source.
- c) Background corrections for the reference sound source.
- d) Fan sound pressure level.
- e) Background corrections for the fan.
- f) Unweighted fan sound power level.
- g) End correction data if applicable:
 - 1) end correction values;
 - 2) duct length;
 - 3) flush, or non-flush, mounting of the duct;
 - 4) inside diameter of the orifice plate.
- h) Test date.

11 Calculations and evaluations

11.1 Calculation of one-third octave band levels

The one-third octave band sound power levels shall be combined to determine the octave band sound power levels as follows:

$$L_{W63} = 10 \lg \left[10^{\frac{L_{W50}}{10}} + 10^{\frac{L_{W63}}{10}} + 10^{\frac{L_{W80}}{10}} \right]$$

$$L_{W125} = 10 \lg \left[10^{\frac{L_{W100}}{10}} + 10^{\frac{L_{W125}}{10}} + 10^{\frac{L_{W160}}{10}} \right]$$

to

$$L_{W8000} = 10 \lg \left[10^{\frac{L_{W6300}}{10}} + 10^{\frac{L_{W8000}}{10}} + 10^{\frac{L_{W10000}}{10}} \right]$$

11.2 Calculation of overall sound power levels

The overall sound power levels shall be calculated from the one-third octave band levels according to the following expression:

$$L_W = 10 \lg \left[10^{\frac{L_{W50}}{10}} + 10^{\frac{L_{W63}}{10}} + \dots + 10^{\frac{L_{W8000}}{10}} + 10^{\frac{L_{W10000}}{10}} \right]$$

11.3 Calculation of A-weighted sound power level

The overall A-weighted sound power level, dBA, shall be calculated from the one-third octave band levels. For each one-third octave band, the A-weighted sound power level is calculated from the formula:

$$L_{WA \text{ band}} = L_{W \text{ band}} + C$$

where C is the correction taken from ISO 3744, Table 2 to be added to the one-third octave band sound pressure level to derive the A-weighted sound pressure level in that frequency band. The overall A-weighted sound power level is then calculated from the expression:

$$L_{WA} = 10 \lg \left[10^{\frac{L_{WA50}}{10}} + 10^{\frac{L_{WA63}}{10}} + \dots + 10^{\frac{L_{WA8000}}{10}} + 10^{\frac{L_{WA10000}}{10}} \right]$$

11.4 Evaluation

Depending on the basic method used, the tests shall be evaluated:

- determination of (A-weighted) sound power level and, if required, in octave bands or in one-third octave bands, or
- determination of sound power level in octave bands or in one-third octave bands, and on this basis, calculation of the A-weighted sound power level.

12 Test report

The test report shall include the information given in 12.1 to 12.4.

12.1 General

The sound power levels shall be reported, together with a statement that they have been obtained in full conformance with the procedures of this part of ISO 13347.

The report shall state that these sound power levels are given in decibels, reference 1 pW. The reported decibel shall be rounded off to the nearest whole number.

In addition, the report shall contain the following information:

- a) manufacturer's fan designation;
- b) manufacturer's size reference and specified rotational speed;
- c) type of test installation (type A, B, C or D); whether measurements are at inlet or outlet of fan and whether the noise includes contributions from the drive and transmission, e.g. installation type B, free-inlet sound power level plus casing-radiated noise, $L_{W(B,in + Cas)}$;
- d) for enveloping surface methods, the surface over which the sound pressure levels were made, e.g. parallelepiped, hemisphere or sphere;
- e) inlet airflow rate and sound power level at the test condition;
- f) inlet airflow rate and sound power level at the specified speed.

The test report shall give the designation of the method and the details listed in 11.1 to 11.4.

12.2 Description of test site, arrangement of fan, location of measuring points

The sound power level determined shall be designated as described in Table 1.

12.3 Instrumentation used

The test report shall detail the instrumentation used.

12.4 Subjective assessment of the noise character

In particular, any discrete tones which are distinctly audible shall be indicated. The test report should detail the equation used.

12.5 Measured values and test results

According to the method used, some or all of the following shall be reported as appropriate:

- a) sound pressure level (A-weighted and/or in frequency bands) at each measuring point;
- b) background-noise sound pressure level (A-weighted and/or in frequency bands) at each measuring point;
- c) background-noise correction, K_1 (A-weighted and/or in frequency bands);
- d) environmental correction, K_2 (A-weighted and/or in frequency bands), in cases where the enveloping surface method is used; air temperature, in °C, relative humidity, in %, and barometric pressure, in mbar, in cases where the reverberation room method is used;

- e) measurement-surface sound pressure level, L_p (A-weighted and/or in frequency bands), and measurement surface ratio, $\overline{AC_1} L_s, \overline{AC_1}$ in cases where the enveloping surface method is used;
- f) a-weighted sound power level, L_{WA} , and if required, sound power level for each octave band or one-third octave band in the frequency range of interest; uncertainty of measurement for L_{WA} if necessary.

Annex A (normative)

Effect of rotational speed changes

The rules for conversion applicable in this Annex relate to changes of speed only with the purpose of correcting the sound power level determined from measurements at the test speed to fixed or specified speeds, not differing by more than 5 % from the test speed.

The rule for change of rotational speed is for each one-third octave band test point,

$$L_{W_o} - L_{W_t} = 50 \lg \left[\frac{n_o}{n_t} \right]$$

where the subscript, *o*, relates to the specified speed and the subscript, *t*, relates to the test speed.

This formula should not be used for any purpose other than scaling for this speed change.

This formula should not be used to scale A-weighted overall noise levels.

Annex B (informative)

Change of gas or air conditions

The sound power level L_W under the gas or air conditions of the test is given by the following:

$$L_W = \bar{L}_p + 10 \lg \frac{S}{S_0} - 10 \lg \frac{\rho c}{400}$$

where

\bar{L}_p is the average sound pressure level over the measurement surface, including the frequency corrections; depending on the test method used (e.g. background noise correction K_1 and environmental correction K_2 for the enveloping surface method);

S is the area of the measurement surface;

$S_0 = 1 \text{ m}^2$;

c is the speed of sound under the gas or air conditions of the test;

ρ is the air density under the gas or air conditions of the test.

The correction given as $10 \lg \rho c$ over 400 will not exceed 1 dB, provided that the barometric pressure lies between 90 kPa and 110 kPa and the ambient dry bulb temperature t is between 10 °C and 30 °C. This correction should not be made if the density/sound speed term exceeds 3 dB.

Annex C (normative)

Corrections for end reflection

C.1 General

When ducted fan equipment is tested in a room, conditions at the end of the duct can prevent some of the sound energy emitted into the duct from being transmitted into the test room. Because of this, the sound power measured in the room may be smaller than the true sound power of the fan equipment. Duct-end correction adjustment E_W is applied to the raw data in order to obtain true fan sound power levels.

It shall be emphasised that this correction is based on theoretical considerations only. Supporting experimental verification is limited. For many years, however, it has been the custom and practice to use end correction as a means of converting noise levels obtained from reverberant and free field tests to in-duct levels needed for the acoustical design of duct systems. It shall be emphasised that, with the present state of knowledge, this is an approximation only. It takes no account of the acoustical loading on the fan inlet or outlet as described in 8.1. Wherever possible, in-duct sound power levels should be obtained directly from tests conducted in accordance with ISO 5136

Duct-end correction adjustment E_W is determined by using Figure C.1. When inlet parameters are used, inlet correction E_i is determined; when outlet parameters are used, outlet end correction E_o is determined. Adjustments are applied as indicated in the example.

NOTE Transmission elements are also subjected to end corrections. See ISO 13347-2.

C.2 End reflection and duct-end correction

Figure C.1 gives the end reflection correction as a function of duct size parameter $0,5 kd$ for several duct-end conditions.

NOTE Airflow conditions are known to influence end reflection. Airflow is not a parameter in Figure C.1 because the magnitude of the effect is considered to be within the uncertainty of this part of ISO 13347.

C.2.1 Duct termination condition

The end reflection correction varies with the termination condition of a duct. Figure C.1 shows the end correction for two termination conditions: non-flush and flush. The non-flush termination is presumed when a duct terminates well inside the test room. The flush duct-end condition is presumed when a duct terminates flush with a single surface of the room.

NOTE 1 Duct termination near room boundaries (other than the flush wall of a flush termination) can result in an end reflection different from that presumed by Figure C.1. A non-flush duct should terminate well away from all room boundaries; a flush duct should terminate well away from all room boundaries other than that with which the duct is flush.

An inlet bell, outlet diffuser, or a flange at the end of a duct, if present, tends to reduce the amount of end reflection relative to that of a duct without such a termination, and should be avoided. A bell or diffuser may be needed to achieve the desired aerodynamic performance, however, or a flange may be necessary for duct stiffening. When an inlet bell or outlet diffuser is used, the duct size for Figure C.1 shall be that of the duct without the device. The width of a flange should be limited to no more than 10 % of the width of the duct (diameter for a round duct, the smaller of length or width for a rectangular duct).

NOTE 2 The actual end reflection with an inlet bell or outlet diffuser is likely to be smaller than that presumed by Figure C.1.

NOTE 3 The acoustical condition with a wide flange termination (flange width exceeding the wavelength of sound) theoretically approaches that of the flush termination condition.

C.2.2 Orifice condition

Measuring the sound emission from a duct obstructed by an orifice is generally not recommended. When an orifice is unavoidable, the end reflection correction is determined from Figure C.1. The size of the orifice is described by the ratio of duct area to orifice open area. For area ratios other than those shown in Figure C.1, obtain the end reflection correction by interpolating between the curves shown.

NOTE 1 For round ducts and orifices, the area ratio is equal to the square of the diameter ratio.

NOTE 2 The mechanical properties of an orifice plate affect its acoustical properties ^[10].

Figure C.1 assumes that an orifice plate is rigid and heavy. For the purpose of this part of ISO 13347, it is recommended that an orifice plate be steel not less than 10 mm thick, or equivalent, and be securely fastened to the end of the duct using a minimum of eight bolts of adequate size and placement. For ducts over 1 m diameter, consideration should be given to using thicker plate and additional stiffening.

C.3 Limitations

Research on duct-end corrections has shown that the necessary correction becomes less predictable as the duct diameter, frequency, and size of an orifice opening decreases. The values for the end reflection correction adjustment provided by Figure C.1 are considered to have acceptable uncertainty when sound testing is performed within the following limitations:

- a) the test frequencies do not lie below the 63 Hz octave band;
- b) the test duct diameter is not less than 0,3 m;
- c) the ratio of duct area to orifice open area (Figure C.1 parameter r_d) does not exceed 5.

If tests shall be conducted such that the above limits would be exceeded, consideration should be given to using a different test method.

C.4 Example of a determination of a duct-end correction adjustment

Given an open (no orifice) inlet duct, duct diameter, d , of 1,016 m, determine the inlet end correction adjustment for a non-flush termination condition in a test room maintained at 20 °C.

The value for octave band 1 is determined according to Table C.1.

Table C.1 — Duct-end correction for octave band

| Quantity | SI units |
|--|---------------------------------------|
| Speed of sound, c (dry air at 20 °C) | 343 m/s |
| Midband frequency, f | 63 Hz |
| Wavelength, $\lambda = cf$ | $343/63 = 5,44$ m |
| Wavenumber, $k = 2\pi/\lambda$ | $2\pi/5,44 = 1,15$ m ⁻¹ |
| Figure C.1 parameter, $0,5 kd$ | $0,5 \times 1,15 \times 1,016 = 0,58$ |
| Figure C.1 result, E_i | 6,1 dB |

Values for other octave bands are determined similarly, with the results given in Table C.2.

Table C.2 — Duct-end correction for octave bands from 63 Hz to 8 000 Hz

| | Octave band mid-frequency Hz | | | | | | | |
|---------------------------------|--|-----|------|-----|------|------|------|------|
| | 63 | 125 | 250 | 500 | 1000 | 2000 | 4000 | 8000 |
| Parameter, $0,5 kd$ | 0,59 | 1,2 | 2,3 | 4,7 | 9,3 | 19 | 37 | 74 |
| Duct-end correction, E_i (dB) | 6,1 | 2,5 | 0,77 | 0 | 0 | 0 | 0 | 0 |
| NOTE | The above is a typical determination that is valid only for the duct parameters given in this example. | | | | | | | |

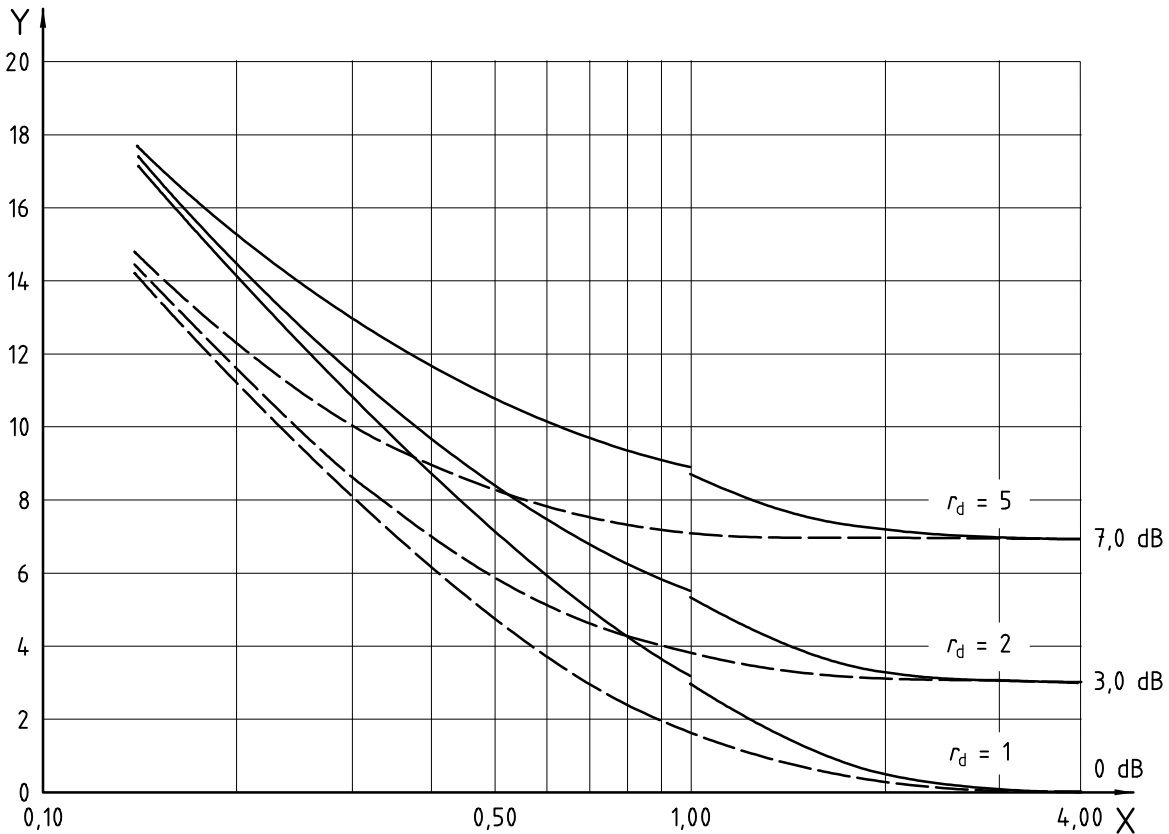

Key

X Parameter, $0,5 kd$

Y End reflection correction, E (dB)

- End correction for open ducts in infinite space (non-flush)
- - - - - End correction for open ducts terminated in a wall (flush)

NOTE 1 For rectangular ducts, use the equivalent diameter, d_e :

$$d_e = \sqrt{4ab/\pi}$$

where a and b are the sides of the rectangular ducts.

NOTE 2 Ratio of duct area/orifice area, r_d :

$$r_d = \left(\frac{d}{d_o} \right)^2$$

where d_o is the diameter of the orifice.

Use $r_d = 1$ if there is no orifice over the opening.

NOTE 3 Wave number, k :

$$k = \frac{2\pi}{\lambda}$$

NOTE 4 Lower limit value for $0,5 kd$ is 0,14. If $0,5 kd$ is less than 0,14, do not report sound power data.

NOTE 5 d and λ should be in consistent units.

Figure C.1 — End reflection correction

Annex D (informative)

Simplified anechoic termination

As seen in 8.1, it is essential to have an anechoic termination at the end of each duct, even on terminating ducts in which no sound measurements are made. Table 4 specifies the maximum permissible values for the pressure reflection coefficient of the anechoic terminations of the test duct and terminating duct.

To fulfil the maximum pressure reflection coefficient requirements, the termination of the test ducts should be fully anechoic. Guidelines for the design of such a termination are presented in Annex E of ISO 5136:2003. For terminating ducts, the requirements are less severe. Test have shown that the following duct end configurations, depending on the duct diameter d , could fulfil the maximum reflection coefficient values of Table 4 for terminating ducts:

- $d \geq 1\,600$ mm: open duct end;
- $800 \leq d < 1\,600$ mm: one cylindrical ducted silencer of $2d$ length (Figure D.1);
- $400 \leq d < 800$ mm two cylindrical ducted silencers in series of $2d$ length (Figure D.2);
- $d < 400$ mm: full anechoic termination (see Annex E of ISO 5136:2003).

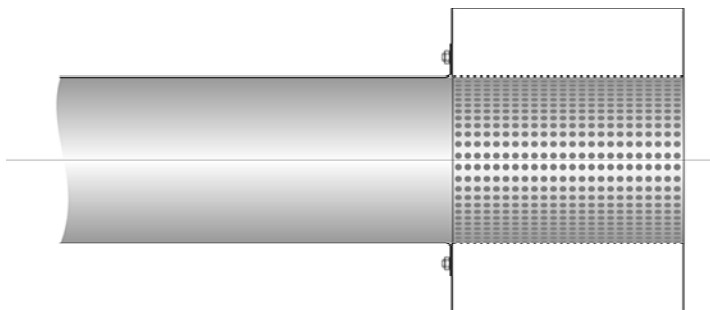

Figure D.1 — Ducted silencer (sectional view)

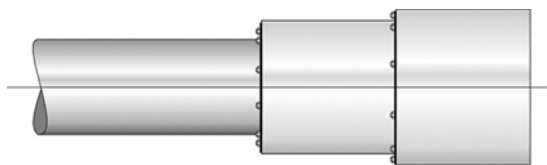

Figure D.2 — Ducted silencers in series

Annex E (normative)

Uncertainty analysis

E.1 General

The analysis of the uncertainty associated with measurements performed with this part of ISO 13347 provides identification of certain critical points of the proposed method, so as to recognise the limitations of the results. Furthermore, it provides an approximation, in real values, of the imprecision in the recorded results.

E.2 Definitions

Precision error is an error which causes readings to take random values on either side of some mean value.

Systematic error is an error that persists and cannot be considered as due entirely to chance.

Uncertainty is an estimated value for the error, i.e., what we think an error would be if we could and did measure it by calibration. Although uncertainty may be the result of both precision and systematic errors, only precision errors can be treated by statistical methods.

The uncertainty in the researched value is described by specifying the measured value followed by the uncertainty interval at the desired confidence level:

$$W = m \pm w, \text{ at } P \text{ confidence level}$$

where

m is the measured value;

w is the uncertainty;

P confidence level, expressed in %.

E.3 Uncertainties

The uncertainties associated with measurements of power levels performed in accordance with the standard are room response (E.4), fan operating points (E.5), instrument error (E.6) and RSS (E.7). Uncertainties associated with duct-end corrections involve the accuracy of estimating the losses from orifice plates (E.8). Other areas of interest involve the use of full or one-third octave bands (E.9) and the problems associated with testing and rating in the 63 Hz band (E.10).

E.4 Room response

A reverberant room is an appropriate place for measuring the acoustical power of a source emitting steady sound power, such as a fan. However, the room shall be diffuse enough to produce a reverberant field.

When a sound source is operated inside a reverberant room, the sound waves are reflected by the walls, and are propagated in all directions. If the paths of all the waves could be seen, we would notice a number of repetitions (for example: the path followed by a wave reflected between two parallel walls). These particular paths are called *normal modes*. The greater the number of normal modes, the better the sound dispersion inside the room. The modes shall be sufficiently numerous in any measurement band so that the microphone

traverse will serve to average the sound pressure. The number of normal modes in a given space increases with frequency. Hence, it is usually more precise to measure higher frequencies. When the number of modes are few, it helps to measure the sound in many locations and average the results. Two important sources of error may affect the measurements taken in a reverberant room:

- a) the error introduced by measuring the sound field at a limited number of points, and
- b) variations of sound power with the source location.

Many sources radiate sound which is not entirely broadband, but contains significant discrete-frequency components called, in common usage, *pure tones*. Some fans generate a pure tone at the blade frequency, and sometimes at harmonic frequencies.

In a reverberant room, these pure tones tend to excite certain modes, which will dominate all the others. This will noticeably increase the variability of the pressure field, due to an insufficient dispersion of the sound field. Consequently, the precision of the results is reduced due to the inaccuracy of the sound pressure averaging.

E.4.1 Broad-band measurement in a reverberant room

Broad-band sound is uniformly distributed in frequency, with relatively steady levels and with no prominent discrete-frequency or narrow-band components. Measurements of broad-band sound may be taken in a room qualified according to Annex A of ISO 13347-2:2004.

E.4.2 Pure tone measurement in a reverberant room

When a discrete-frequency component is present in the spectrum of a source, the spatial variations in the sound pressure level usually exhibit maxima separated by minima having an average spacing of approximately $0,8\lambda$, where λ is the wavelength corresponding to the discrete frequency of interest.

The presence of a significant discrete-frequency component in the noise produced by a source can often be detected by a simple listening test. If such a component is audible, or detectable by narrow-band analysis, the qualification procedure described in Annex B of ISO 13347-2:2004 is recommended.

If the room is not qualified for pure tone measurement, the measurement uncertainty will most probably be higher in the bands containing the blade passage frequency and its harmonics than if measured in a qualified room. Typical uncertainties may have a magnitude of ± 8 dB.

Discrete-frequency components may be present in the spectrum, even when these components are not audible. A conclusion that no discrete-frequency components are present can only be reached by performing the test described in E.4.3.

E.4.3 Test for discrete-frequency components

The following procedure can be used to estimate the (spatial) standard deviation of the sound pressure levels produced by the fan under test in the room.

Select an array of six fixed microphones (or a single microphone at six positions) spaced at least $\lambda/2$ apart, where λ is the wavelength of the sound corresponding to the lowest band mid-frequency of interest, and meeting all of the requirements for microphone positions in Annex A of ISO 13347-2:2004. Locate the source at a single position in the test room in accordance with Annex A of ISO 13347-2.

AC1 Obtain the time-averaged sound pressure level, L_{pj} , at each microphone position according to the techniques described in Annex A.

For each one-third octave band within the frequency range of interest, calculate the standard deviation, s , from the following equation:

$$s = \left[\frac{1}{n_m - 1} \sum_{j=1}^{n_m} (L_{pj} - \overline{L_{pj}})^2 \right]^{1/2} \quad \text{AC1}$$

AC1 where

L_{pcj} is the sound pressure level, corrected for the background noise level in accordance with the procedures of 6.2.1, for the microphone position, expressed in decibels;

$\overline{L_{pj}}$ is the arithmetic mean of (L_{pcj}) values, averaged over all microphone positions, expressed in decibels;

n_m is the number of microphone positions (= 6). AC1

The magnitude of s depends upon the properties of the sound field in the test room. These properties are influenced by the characteristics of the room, as well as the characteristics of the noise source (i.e., directivity and spectrum of the emitted sound). In theory a standard deviation of 5,57 dB corresponds to a spectral component of zero bandwidth, i.e. a discrete tone.

Table E.1 — Characterisation of the presence of discrete-frequency or narrow-band components, based upon the spatial variation of the sound field

| Standard deviation, s dB | Characterisation |
|-------------------------------|---|
| $s < 1,5$ | Assume broad-band source. Use procedures of Annex A of ISO 13347-2:2004. |
| $1,5 < s < 3$ | Assume that a narrow-band of noise is present. Recommend use of the qualification procedure in Annex B of ISO 13347-2:2004. |
| $s > 3$ | Assume that a discrete tone is present. Test room shall qualify in accordance with Annex B of ISO 13347-2:2004. |

E.5 Fan operating points

Whenever the sound power level of a fan is measured, each measurement shall relate to one point of operation of the fan. Uncertainty in identifying this point thus affects the global uncertainty of the results. It is therefore recommended that the procedures of ISO 5801 or other recognised fan performance test standard be used as a guideline in identifying the operating points. The sound level sensitivity to change in the point of operation is a function of the product characteristics and this will dictate how accurately the point of operation measurement should be made. Fans that have a large sound power level change as flow is changed, at a given speed, are of more concern than fans that show a small sound power level change for the same flow change.

E.6 Instrument error

The frequency response of the instrumentation system shall be flat over the frequency range of interest, to within the tolerances given in Table E.2.

Table E.2 — Tolerances for the Instrumentation System

| Frequency Hz | Tolerance dB |
|-----------------|-----------------|
| 50 to 80 | ± 2,0 |
| 100 to 400 | ± 1,0 |
| 5 000 to 8 000 | ± 1,5 |
| 10 000 | ± 2 |

E.7 Reference sound source (RSS)

The sound power produced by the reference sound source shall be determined in octave and one-third octave bands within the tolerances specified in Table E.3.

Table E.3 — Calibration for sound reference source

| One-third octave band mid-frequency Hz | Tolerance dB |
|--|-----------------|
| 50 to 80 | ± 2,0 |
| 100 to 160 | ± 1,0 |
| 200 to 4000 | ± 0,5 |
| 5000 to 10000 | ± 1,0 |

E.8 Duct-end corrections

The curves shown on Figure C.1, which indicate the losses present at the duct end, were developed from an analysis of the results of research conducted [5]. This same research also addresses the limits of duct size and orifice size.

Table E.4 gives the uncertainties for the end reflection correction E , for various $0,5 kd$ and r_d values. This table was developed from the results of research [5] and the available theory. It is believed that end reflections are, in general, poorly understood. This part of ISO 13347 stresses that the test set-ups should simulate the intended installations as accurately as possible, reducing (if not entirely eliminating) the need for applying end-reflection correction values.

Table E.4 — Uncertainties in end reflection correction E

| Duct configuration | r_d | Uncertainty in E dB | | |
|--------------------|--------|--------------------------|-----------|-------|
| | | Range of $0,5 kd$ | | |
| | | < 0,25 | 0,25 to 1 | > 1 |
| Flush | 1 | ± 3 | ± 2 | ± 0,5 |
| Free Space | 1 | ± 3 | ± 2 | ± 0,5 |
| | 1 to 2 | ± 3 | ± 2 | ± 0,5 |
| | 2 to 5 | ± 4 | ± 3 | ± 1 |

E.9 Octave band VS one-third octave band

According to this part of ISO 13347, the frequency analysis of sound may be performed either in full octave bands or in one-third octave bands. Qualification of a reverberant room for pure tones can only be effected in the one-third octave band. Full octave band analysis takes less time since fewer numerical values are treated; however, this analysis supplies little information on the shape of a sound spectrum. Furthermore, full octave band analysis does not allow isolation of pure tones in a spectrum; the poor resolution of an octave band gives little information about a steeply sloping spectrum. The pure tone value produced by a fan may be reduced by 1 to 2 dB without changing the octave band reading.

For certain test duct conditions, this part of ISO 13347 uses an end-reflection correction factor which is frequency dependent. Because of this dependence, analysis in full octave band instead of one-third octave band may cause an error of up to ± 2 dB.

EXAMPLE Test conditions:

- fan with 508 mm (20 in) diameter outlet duct;
- no orifice plate;
- low airflow.

There is a significant difference between the two methods of evaluating the octave band values. This difference is a function of two things:

- a) the shape of the one-third octave band spectrum;
- b) the slope of the end reflection attenuation curve at the point where the reflection correction factor is evaluated.

The error made in using the octave band analysis can overestimate or underestimate the real values; therefore, the use of one-third octave band analysis is recommended. Refer to Figure C.1.

If full octave band analysis is performed, a precaution would be to adjust the fan speed to cause the blade passage frequency to fall in the central one-third octave band of any octave band as shown in Tables E.5 and E.6. Care should also be taken to keep the blade passage frequency from falling on the border between bands, thus avoiding the problems associated with filter-skirt characteristics.

Table E.5 — Octave band analysis

| One-third octave mid-frequency Hz | L_p Measured | L_p Combined | E | $(L_p + E)$ dB |
|--------------------------------------|-------------------|-------------------|------|-------------------|
| 50 | 80 | | | |
| 63 | 65 | 80,2 | 10,2 | 90,4 |
| 80 | 64 | | | |

Table E.6 — One-third octave band analysis

| One-third octave mid-frequency Hz | L_p | E | $(L_p + E)$ dB | $(L_p + E)$ Combined dB |
|--------------------------------------|-------|------|-------------------|-------------------------------|
| 50 | 80 | 12,1 | 92,1 | |
| 63 | 65 | 10,2 | 75,2 | 92,2 |
| 80 | 64 | 8,3 | 72,3 | |

Annex F (normative)

Calibration of reference sound source

F.1 General

Calibration of a reference sound source (RSS) in conformance with the requirements of ISO 6926 requires a hemi-anechoic room qualified for measurements over the entire frequency range of interest. Laboratories that otherwise would be able to perform the required calibration, but that are not qualified for measurements in the first octave band, may use the alternative procedure of this annex. This alternative procedure is based on sound intensity measurements according to ISO 9614-1.

F.2 Equipment and facilities

Equipment and facilities shall be as required for RSS calibration in conformance with ISO 6926, with the exception that the hemi-anechoic chamber need not be qualified below the 125 Hz octave band (100 Hz one-third octave band). Sound intensity measuring equipment shall comply with the requirements of ISO 9614-1.

Additional reference sound sources may be sound power level calibrated by comparing the sound level of the source to another reference sound source that was calibrated in accordance with F.1 to F.5. The measurement procedure shall be in accordance with ISO 3741.

F.3 Qualification

The RSS calibration procedure of ISO 6926 shall be carried out over the 50 to 10 000 Hz one-third octave band frequency range and 63 to 8 000 Hz octave band range. If the calibration is in conformance with ISO 6926 in all respects, except for the qualification of the test facility below the 100 Hz one-third octave band, the alternative calibration procedure below may be used. If the calibration is not in complete conformance with ISO 6926 for any other reason, the alternative calibration procedure is not applicable.

F.4 Procedure

The requirements of ISO 6926 are duplicated in the lowest 3 octave (9 one-third octave) bands, with the substitution of sound intensity level measurements made in compliance with ISO 9614-1 for the sound pressure level measurements required by ISO 6926. For all measurements, sound intensity shall be measured in the outward radial direction. The sound power levels determined from these measurements shall be compared with those determined from the corresponding sound pressure level measurements. If, in all frequency bands, the determined sound power levels differ by no more than the tolerance of Table F.1, the calibrated sound power levels for the RSS are reported as specified in F.5. The directivity index is not calculated from the intensity measurements.

Table F.1 — Tolerance for sound power level difference

| Octave band Hz | One-third octave band Hz | Tolerance dB |
|-------------------|-----------------------------|-----------------|
| 63 | 50 to 80 | ± 4 |
| 125 to 250 | 100 to 315 | ± 1,0 |

F.5 RSS sound power levels

The reported RSS sound power level and directivity index shall be those determined by the ISO 6926 procedure for the 100 to 10 000 Hz one-third octave and 125 to 8 000 Hz octave bands. For the 50 to 80 Hz one-third octave bands and 63 Hz octave band, the reported RSS sound power level shall be that determined from the intensity measurements, and the directivity index is not reported. The calibration report shall be marked to indicate the levels determined from intensity measurements, and shall indicate whether the calibration was performed in full compliance with this Annex.

Annex G (informative)

Filter weighted measurements

In certain sound measurement situations, the presence of high amplitude sound at low frequency (below 45 Hz) can reduce the effective dynamic range of the analyser in the measurement frequency range of interest for this part of ISO 13347 (45 Hz to 11,2 kHz). While use of an analyser with a large dynamic measurement range can possibly solve the problem, it may sometimes be necessary to use another approach.

Sound pressure level readings may be made with the sound level meter or signal amplifier set for a well defined filter weighting effect, in order to improve the dynamic range and measurement quality, provided that any effect in the frequency range 45 Hz to 11 200 Hz is compensated and the equipment satisfies all the requirements of Clause 4. The filter weighting response shall be less than 3 dB at all frequencies between 45 Hz and 11,2 kHz. The weighting filter shall be the same for all measurements (background, RSS and fan). The filter weighting values shall be added to the sound pressure level measurement spectrums to maintain calibration.

Bibliography

- [1] HARRIS, C.M., Ed., *Handbook of Noise Control*, 2nd Ed., MCGRAW-HILL, New York, 1979, Ch. 1, p. 2
- [2] WOLHER, H. *Zweitormersungen an einen radialventilator modell*. Frankfurt: Forschungsvereinigung für Luft and Trocknungstechnik. 1970, 7(19)
- [3] CREMER, L. *The treatment of fans as black boxes*. Second Annual Fairy lecture. J. Sound & Vibration., 1071, 16(1), pp. 1-15
- [4] GUEDEL, A. *Design of terminating ducts for fan noise testing*, Proceeding of Internoise 2000, August 2000
- [5] BAADE, P. *Effects of acoustic loading on axial flow fan noise generation*. Noise Control Engineering, January-February 1977, 8(1), pp. 5-15
- [6] BOLTON, A. N. & Margetts, Miao, E.J. *The influence of impedance on fan sound power*. National Engineering Laboratory, Dept of Trade & Industry UK publication, C124/84
- [7] PARKER, S. P., Ed., *Dictionary of Scientific and Engineering Terms*, 4th Ed., MCGRAW-HILL, New York, 1989
- [8] SEPMEYER, L. W., *Computed Frequency and Angular Distribution of the Normal Modes of Vibration in Rectangular Rooms*, *Acoustical Society of America*, Vol. 37-No 3, March 1965
- [9] AMCA #1901-85-AI, *List of References on Room Calibration, Air Movement and Control Association, Inc.*, Arlington Heights, IL, 1985
- [10] CROCKER, M. J., w/PANDE, L. and SANDBAKKEN, M., *Investigation of End, Reflection Coefficient Accuracy Problems with AMCA Standard 300-67*, HL 81-16, Purdue University, IN, 1981
- [11] Noise Control Engineering, Vol. 7, No. 2, *Noise Measurement Facilities*, and ANSI S 1.21-1972, *Methods for the Determination of Sound*
- [12] LEVINE, H. SCHWINGER J. *On the radiation of sound from an unflanged circular pipe*, Physical Review Vol. 73 No. 4, Feb. 1948
- [13] FARZAMI, R. and GUEDEL, A., *Influence of Straighteners on In-duct Fan Sound Power Measurements International Fan Noise Symposium*, Senlis 1-3 September 1992
- [14] NEISE, W. *Sound Power Measurement Procedures for Fans. Proceedings of International Conference on Noise & Vibration*. St. Petersburg, Russia. May 31 - June 3, 1993
- [15] GUEDEL, A. *Acoustique des ventilateurs*, ed. PYC Livres, CETIAT 1999
- [16] ISO 2204:1979, *Acoustics — Guide to International Standards on the measurement of airborne noise and evaluation of its effects on human beings*
- [17] ISO 3740, *Acoustics — Determination of sound power levels of noise sources — Guidelines for the use of basic standards*
- [18] ISO 7235:2003, *Acoustics — Laboratory measurement procedures for ducted silencers and air-terminal units — Insertion loss, flow noise and total pressure loss*
- [19] ISO 13348, *Industrial fans — Tolerances, methods of conversion and technical data presentation* (in preparation)
- [20] IEC 60704-2-7:1997, *Household and similar electrical appliances — Test code for the determination of airborne acoustical noise — Part 2: Particular requirements for fans*

BS ISO
13347-1:2004
+A1:2010
BS
848-2.1:2004

BSI - British Standards Institution

BSI is the independent national body responsible for preparing British Standards. It presents the UK view on standards in Europe and at the international level. It is incorporated by Royal Charter.

Revisions

British Standards are updated by amendment or revision. Users of British Standards should make sure that they possess the latest amendments or editions.

It is the constant aim of BSI to improve the quality of our products and services. We would be grateful if anyone finding an inaccuracy or ambiguity while using this British Standard would inform the Secretary of the technical committee responsible, the identity of which can be found on the inside front cover. Tel: +44 (0)20 8996 9000. Fax: +44 (0)20 8996 7400.

BSI offers members an individual updating service called PLUS which ensures that subscribers automatically receive the latest editions of standards.

Buying standards

Orders for all BSI, international and foreign standards publications should be addressed to Customer Services. Tel: +44 (0)20 8996 9001. Fax: +44 (0)20 8996 7001 Email: orders@bsigroup.com You may also buy directly using a debit/credit card from the BSI Shop on the Website <http://www.bsigroup.com/shop>

In response to orders for international standards, it is BSI policy to supply the BSI implementation of those that have been published as British Standards, unless otherwise requested.

Information on standards

BSI provides a wide range of information on national, European and international standards through its Library and its Technical Help to Exporters Service. Various BSI electronic information services are also available which give details on all its products and services. Contact Information Centre. Tel: +44 (0)20 8996 7111 Fax: +44 (0)20 8996 7048 Email: info@bsigroup.com

Subscribing members of BSI are kept up to date with standards developments and receive substantial discounts on the purchase price of standards. For details of these and other benefits contact Membership Administration. Tel: +44 (0)20 8996 7002 Fax: +44 (0)20 8996 7001 Email: membership@bsigroup.com

Information regarding online access to British Standards via British Standards Online can be found at <http://www.bsigroup.com/BSOL>

Further information about BSI is available on the BSI website at <http://www.bsigroup.com>

Copyright

Copyright subsists in all BSI publications. BSI also holds the copyright, in the UK, of the publications of the international standardization bodies. Except as permitted under the Copyright, Designs and Patents Act 1988 no extract may be reproduced, stored in a retrieval system or transmitted in any form or by any means – electronic, photocopying, recording or otherwise – without prior written permission from BSI.

This does not preclude the free use, in the course of implementing the standard, of necessary details such as symbols, and size, type or grade designations. If these details are to be used for any other purpose than implementation then the prior written permission of BSI must be obtained.

Details and advice can be obtained from the Copyright and Licensing Manager. Tel: +44 (0)20 8996 7070 Email: copyright@bsigroup.com

BSI Group
Headquarters 389
Chiswick High Road,
London, W4 4AL, UK
Tel +44 (0)20 8996 9001
Fax +44 (0)20 8996 7001
[www.bsigroup.com/
standards](http://www.bsigroup.com/standards)