

Determination of particle size distribution by centrifugal liquid sedimentation methods —

Part 2: Photocentrifuge method

ICS 19.120

National foreword

This British Standard is the UK implementation of ISO 13318-2:2007. It supersedes BS ISO 13318-2:2001 which is withdrawn.

The UK participation in its preparation was entrusted to Technical Committee LBI/37, Sieves, screens and particle sizing.

A list of organizations represented on this committee can be obtained on request to its secretary.

This publication does not purport to include all the necessary provisions of a contract. Users are responsible for its correct application.

Compliance with a British Standard cannot confer immunity from legal obligations.

This British Standard was published under the authority of the Standards Policy and Strategy Committee on 31 October 2007

© BSI 2007

ISBN 978 0 580 59625 4

Amendments issued since publication

Amd. No.	Date	Comments

INTERNATIONAL
STANDARD

ISO
13318-2

Second edition
2007-09-15

**Determination of particle size distribution
by centrifugal liquid sedimentation
methods —**

**Part 2:
Photocentrifuge method**

*Détermination de la distribution granulométrique par les méthodes de
sédimentation centrifuge dans un liquide —*

Partie 2: Méthode photocentrifuge



Reference number
ISO 13318-2:2007(E)

Contents

Page

Foreword.....	iv
Introduction	v
1 Scope	1
2 Normative references	1
3 Terms, definitions and symbols	1
4 Principle	2
5 Apparatus	2
6 Sampling	6
7 Preparation	6
7.1 Sample preparation	6
7.2 Temperature	6
7.3 Dispersion	6
8 Procedure	6
8.1 Line-start methods.....	6
8.2 Homogeneous technique	7
9 Tests in duplicate and validation	8
9.1 Tests in duplicate.....	8
9.2 Validation.....	8
10 Calculation of results	8
10.1 General.....	8
10.2 Calculation of particle size	8
10.3 Calculation of cumulative mass percentage.....	8
11 Reporting of results.....	9
Annex A (informative) Worked example.....	11
Annex B (informative) Extinction curve, example for titanium dioxide	15
Annex C (informative) Effect of radial dilution	16
Bibliography	17

Foreword

ISO (the International Organization for Standardization) is a worldwide federation of national standards bodies (ISO member bodies). The work of preparing International Standards is normally carried out through ISO technical committees. Each member body interested in a subject for which a technical committee has been established has the right to be represented on that committee. International organizations, governmental and non-governmental, in liaison with ISO, also take part in the work. ISO collaborates closely with the International Electrotechnical Commission (IEC) on all matters of electrotechnical standardization.

International Standards are drafted in accordance with the rules given in the ISO/IEC Directives, Part 2.

The main task of technical committees is to prepare International Standards. Draft International Standards adopted by the technical committees are circulated to the member bodies for voting. Publication as an International Standard requires approval by at least 75 % of the member bodies casting a vote.

Attention is drawn to the possibility that some of the elements of this document may be the subject of patent rights. ISO shall not be held responsible for identifying any or all such patent rights.

ISO 13318-2 was prepared by Technical Committee ISO/TC 24, *Sieves, sieving and other sizing methods*, Subcommittee SC 4, *Sizing by methods other than sieving*.

This second edition cancels and replaces ISO 13318-2:2001, of which it constitutes a minor revision, due to the extension of Clause 4 and 5.2, and the addition of Figure 3 and the Bibliography.

ISO 13318 consists of the following parts, under the general title *Determination of particle size distribution by centrifugal liquid sedimentation methods*:

- *Part 1: General principles and guidelines*
- *Part 2: Photocentrifuge method*
- *Part 3: Centrifugal X-ray method*

Introduction

The sample suspension in a photocentrifuge may be contained in a cuvette or a disc. Sample concentration is determined by changes in a light signal monitored at a known radius. The cuvette photocentrifuge can only be run in the homogeneous mode whereas the disc photocentrifuge may be run in either the homogeneous or the line-start mode. Some systems permit the coarse end of the distribution to be measured in a gravitational mode and the fine end in the centrifugal mode. The use of light to determine particle size distribution requires a calibration factor to be applied as the particle size approaches the wavelength of the light, due to the inapplicability of the laws of geometric optics.

Determination of particle size distribution by centrifugal liquid sedimentation methods —

Part 2: Photocentrifuge method

WARNING — This part of ISO 13318 may involve hazardous materials, operations and equipment. This part of ISO 13318 does not purport to address all of the safety problems associated with its use. It is the responsibility of the user of this part of ISO 13318 to establish appropriate safety and health practices and determine the applicability of the regulatory limitations prior to its use.

1 Scope

This part of ISO 13318 covers methods for determining the particle size distribution of particulate materials by means of centrifugal sedimentation in a liquid. Solids concentrations are determined by the transmission of a light beam. The resulting signal enables conversion to a particle size distribution.

The method of determining the particle size distribution described in this part of ISO 13318 is applicable to powders that can be dispersed in liquids, powders that are present in slurry form and some emulsions. Typical particle size range for analysis is from about 0,1 μm to 5 μm . The method is applicable to powders in which all particles have the same density and comparable shapes and do not undergo chemical or physical change in the suspension liquid. It is usually necessary that the particles have a density higher than that of the liquid.

2 Normative references

The following referenced documents are indispensable for the application of this document. For dated references, only the edition cited applies. For undated references, the latest edition of the referenced document (including any amendments) applies.

ISO 13318-1, *Determination of particle size distribution by centrifugal liquid sedimentation methods — Part 1: General principles and guidelines*

ISO 14887, *Sample preparation — Dispersing procedures for powders in liquids*

3 Terms, definitions and symbols

For the purposes of this document, the terms, definitions and symbols given in ISO 13318-1, and the following symbols, apply.

D	optical density
E_i	extinction coefficient for a particle of diameter x_i
$F(\text{surface})$	frequency undersize by surface
G	constant dependent upon the geometry of the system, the dimensions of the light beam and on the shape of the particles

l	transmission of the emergent light beam, at the time t , after the start of sedimentation
l_0	transmission of the emergent light beam when no particles are present
M	distance from rotation axis to measurement zone (mm)
n_i	number of particles of diameter x_i in the beam
R	distance from rotation axis to centrifuge wall, inner disc radius (mm)
S	distance from rotation axis to liquid/air interface of sample (mm)
x_0	diameter of the smallest particle in the light beam (μm)
x_{St}	diameter of the largest particle in the light beam, i.e. the Stokes diameter (μm)

4 Principle

A stable, finely collimated beam of light passes through a spinning disc or cuvette and sedimenting sample and is detected at a known radius. Light rays, typically from either a white light source (e.g. incandescent bulb) or a monochromatic coherent source (e.g. laser), pass through the suspension and are detected by a photodiode or photomultiplier. The disc photocentrifuge can be operated in the line-start or homogeneous mode whereas the cuvette photocentrifuge can be operated only in the homogeneous mode. The signal of the light beam is monitored over the analysis time. The mass percentage of sample present in the beam is determined by calculating the ratio of the light transmission signal, by use of a clear dispersing liquid, to the light transmission signal with the sample present.

In the line-start mode the disc initially contains clear fill liquid to give maximum light transmission. Then the sample is injected as a thin layer on top of the spinning fill liquid and begins to settle outward radially. When the largest particles present reach the light beam the light transmission decreases, returning to the original transmission value when the smallest particle present passes through the beam. A buffer layer is usually injected over the fill liquid to prevent suspension breaking through the interface in a phenomenon known as “streaming”.

In an alternative configuration, the determination of the particle size distribution by centrifugal liquid sedimentation method can also be accomplished using a photocentrifuge containing a line light source and a line sensor detector system aligned with the sample cell. In this configuration, light intensity/extinction alterations during centrifugation are measured simultaneously over the whole sedimentation zone as a function of both time and of position. From these data, the particle size distribution may be calculated either from the time course of the extinction at a freely selectable position within the sample [numerical integration, ISO 13318-1:2001, Equation (11) in 4.3.3.3] or from the extinction profile along the sample at a freely selectable time (analytical integration, for details see Reference [1]).

5 Apparatus

5.1 Disc photocentrifuge, with a chamber consisting of a hollow disc with an entry port coaxial with the axis of rotation (see Figure 1). Typically this is mounted vertically, or at a small angle to the vertical, on to the shaft of an electric motor with a digitally variable speed typically between $500 \text{ r}\cdot\text{min}^{-1}$ and $15\,000 \text{ r}\cdot\text{min}^{-1}$. A white light source and detector assembly measures transmittance through the suspension as a function of time. The instrument can be used in either a line-start or homogeneous mode. Extinction coefficient corrections need to be applied for the breakdown in the laws of geometric optics for both line-start and homogeneous modes. Additionally, a correction is required for radial dilution effects when the homogeneous mode is used. Software is provided with commercial equipment to convert the data directly into size distributions in the form of tables or graphs of cumulative mass percentage versus particle size.

5.2 Cuvette photo-centrifuge, in which the disc is replaced with a rectangular cell containing a homogeneous suspension (see Figure 2). Corrections need to be made for both radial dilution and light scattering effects as described in ISO 13318-1. Cuvette photo-centrifuges can typically be run in both the gravitational and centrifugal modes. Additionally, some systems may offer a gradient mode permitting the centrifuge to accelerate throughout the analysis in order to reduce the measurement time.

When determining particle size distribution using an apparatus containing a line light source and a line sensor detection system, transmittance is measured along the entire sedimentation zone simultaneously (see Figure 3).

5.3 Ancillary apparatus, consisting of:

- dispersing vessel, e.g. glass beaker or bottle, of appropriate dimensions;
- flexible spatula;
- ultrasonic bath or probe, a bottle shaker or high speed mechanical stirrer capable of rotating at $500 \text{ r}\cdot\text{min}^{-1}$ to $1\,000 \text{ r}\cdot\text{min}^{-1}$.

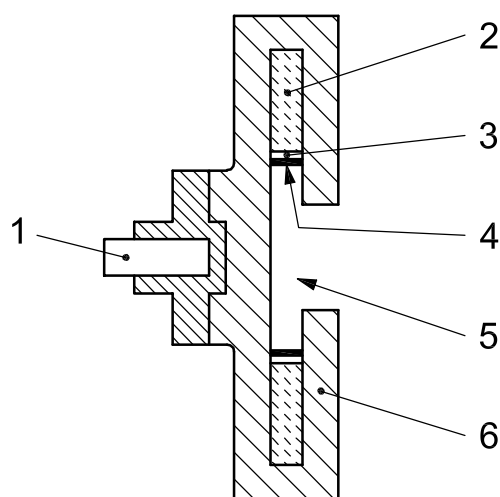

Key

- 1 motor shaft
- 2 spin fluid
- 3 buffer layer
- 4 suspension
- 5 entry port
- 6 polymethylmethacrylate disc

Figure 1 — Side view of the disc of a disc photo-centrifuge

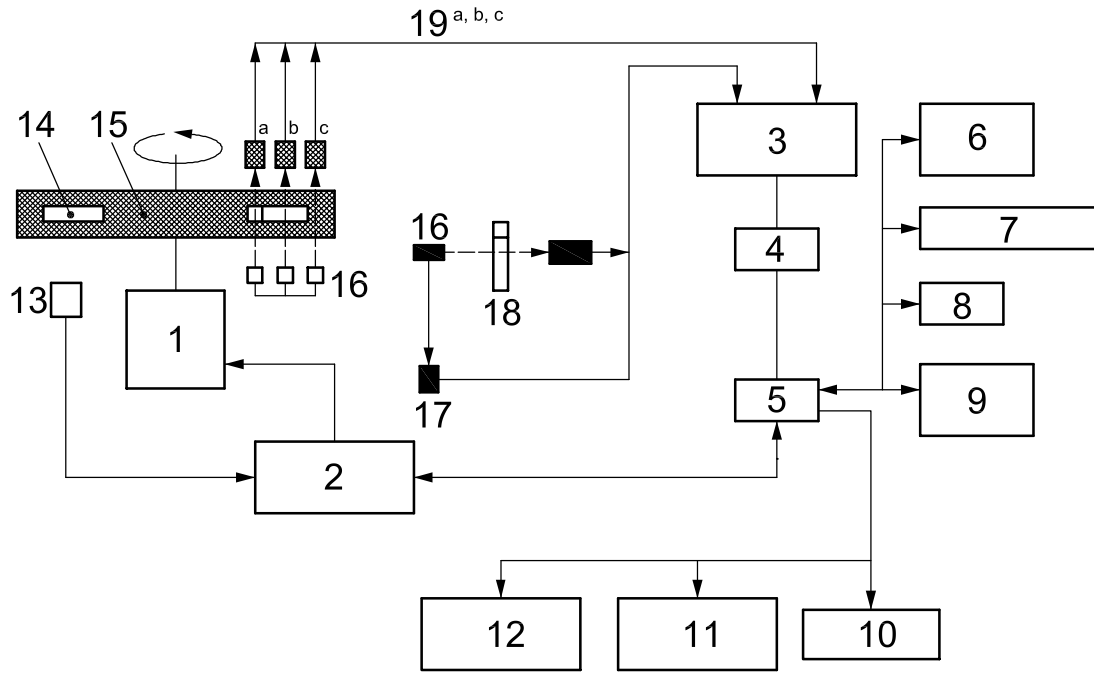

Key

- 1 motor
 - 2 motor control
 - 3 signal process
 - 4 analogue to digital converter (ADC)
 - 5 central processing unit (CPU)
 - 6 date time
 - 7 analysis parameters
 - 8 revolutions per minute (RPM)
 - 9 keyboard
 - 10 printer
 - 11 analog interface
 - 12 computer interface
 - 13 photosensor revolutions per minute (RPM)
 - 14 centrifugal cell
 - 15 rotating disc
 - 16 light-emitting diode (LED)
 - 17 photocell (reference)
 - 18 photocell (sample)
 - 19 photocells
- a Synchro-signal (reference).
 b Analog signal.
 c Synchro-signal (sample).

Figure 2 — Schematic diagram of a typical cuvette photocentrifuge

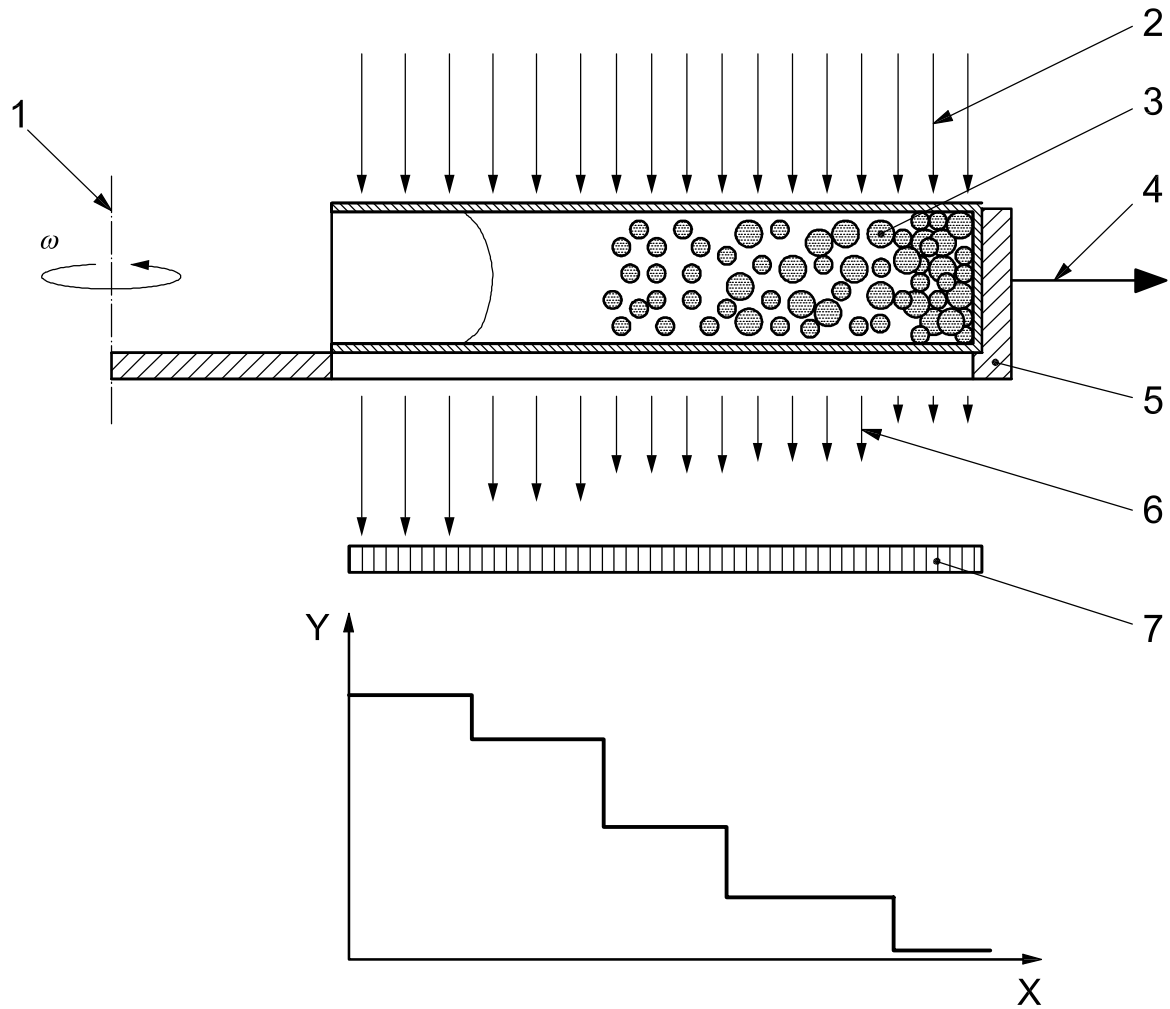
**Key**

- X position for one selected time
- Y intensity
- 1 axis of rotation
- 2 incident parallel light
- 3 sample cell
- 4 centrifugal force
- 5 rotor
- 6 transmitted light
- 7 line detector array

Figure 3 — Schematic diagram of a cuvette photocentrifuge with line light source and line detector array

6 Sampling

For sampling see ISO 13318-1.

7 Preparation

7.1 Sample preparation

An analysis sample shall be prepared as described in ISO 13318-1. The volume and concentration required depends upon the volume of the centrifuge disc (or cuvette), the sensitivity of the optical-electronic system and whether the line-start (disc only) or homogeneous method is to be used. In general, lower concentrations are required than for other sedimentation methods. A mass per volume concentration typically less than 0,25 % and providing an attenuation preferably in the 20 % to 30 % range compared to the spin fluid without sample is required.

7.2 Temperature

The temperature of the spin fluid (line-start method) or suspension (homogeneous method) shall be determined and recorded before and after analysis in accordance with ISO 13318-1. The liquid viscosity and liquid density shall be recorded for the spin fluid or suspension at the temperature of the analysis. The temperature shall be maintained in accordance with ISO 13318-1.

7.3 Dispersion

For dispersion see ISO 13318-1 and ISO 14887.

8 Procedure

8.1 Line-start methods

8.1.1 General

The line-start method is one in which a layer of sample suspension is deposited on a spinning fill liquid, i.e. all particles are considered to have started to sediment from the same initial radius. However, the sample suspension has a tendency to penetrate the surface of the spin liquid as globules of suspension which then "stream" rapidly through the spin liquid. The streaming effect is due to an uneven outward diffusion of the sample suspension. On injection of the sample suspension the particles can become concentrated by surface tension effects at the interface. This leads to a region of high density above one of lower density and causes a bulk transfer of concentrated suspension into the spin fluid. Streaming is particularly prone to happen if the sample suspension is injected directly on to the spin fluid (two-layer method); consequently the two-layer method is in general replaced by the three-layer method (see 8.1.2) due to its applicability to a wider range of sample types. The following methods all attempt to cushion the hydrodynamic shock experienced by the particles as they enter the spin fluid and thus obtain a smooth transition and laminar flow.

Hydrodynamically stable sedimentation can generally be achieved by using the three-layer method, the buffered line or the external gradient method.

8.1.2 Three-layer method

Partially fill the centrifuge disc with a known volume of clear liquid (the spin fluid, typically approximately 15 ml) and allow the disc to attain the required running speed. Set up the light source at the required sampling radius (M). A steady baseline represents maximum transmission (I_0). Introduce into the disc a small volume of buffer liquid, typically 0,5 ml or 1 ml, that is of lower density than the spin fluid and determine the vortex radius (S). This can be done from a knowledge of the dimensions of the disc and the total volume of liquid introduced. Introduce the required volume of suspension (typically 0,25 ml of a 0,25 % mass per volume concentration) into the disc and activate the timer. The expectation is that any rapid turbulence caused by the injection of the sample suspension is restrained to the intermediate (buffer) layer and be used to effect good sample mixing. The spin fluid might typically consist of 15 ml of a 10 % aqueous glycerol (volume fraction) on which is floated 0,5 ml of water as the buffer layer followed by 0,25 ml of sample suspension. If streaming persists it may frequently be eliminated by using much smaller volumes of buffer liquid and sample suspension, e.g. 0,1 ml.

In order for a line-start to be valid, the band of suspension has to be thin relative to the distance from the injection radius (S) to the radius of the measurement zone (M). It is recommended that the thickness of the suspension layer be greater than 5 % of ($M - S$).

As the particles are centrifuged outwards, they attenuate the light beam and the changes in transmission are recorded. Run the experiment until the spin fluid is once again clear and the trace has returned to the baseline. For samples containing a large number of fine particles, it may take a considerable time for the trace to return to the baseline. In these circumstances it may be expedient to terminate the run at an earlier time, e.g. when the signal has fallen to 10 % of the maximum deflection. A second run may then be made at a higher centrifuge speed to cover the fine end of the size range.

8.1.3 Buffered line-start method

This is a variation of the three-layer method. Interpose a thin layer of the suspension medium liquid, rather than a different buffer layer medium, between the spin liquid and the suspension layer. After the addition of the buffer layer, apply transient deceleration to the disc so that the buffer is mixed with the outermost layer of the spin liquid. Inject the suspension sample on to the surface of the mixed layer once the disc has regained synchronous speed. Proceed as in 8.1.2.

8.1.4 External gradient method

Inject 0,2 ml of methanol into a dry, non-rotating disc. Without delay, bring the disc to the required speed and inject 15 ml of distilled or de-ionized water into the spinning disc. Immediately inject 0,1 ml or less dodecane into the disc to minimize evaporative cooling. Wait 5 min to enable the liquids and disc to approach thermal equilibrium and to permit the less dense methanol to rise through the water. Although methanol and water are miscible in all proportions, under the constant centrifugal force the less dense methanol will rise towards the meniscus to produce the required gradient. Inject 0,2 ml of sample, of concentration about 0,1 % by volume, and start the analysis. Record the analysis temperature at the end of the run.

8.2 Homogeneous technique

Fill the centrifuge disc with pure suspending liquid, spin to the required speed and record the I_0 value. Empty the disc. Spin the disc to the required speed and pour in (or inject using a hypodermic syringe) the sample suspension through the entry port as quickly as possible. When the sample addition is complete, activate the timer without delay.

The principle for the cuvette photocentrifuge is outlined in Figure 2. Light from a high intensity source is typically focused in two directions, one through a gravitational sample port and one through the measurement plane of the centrifuge. The collimated beams are filtered with narrow band pass filters. In the centrifugal mode two cells are used. Record the signal difference between the reference cell, containing clean suspension liquid, and the suspension cell once for each revolution. Fill and insert the reference cell with clean liquid followed by the suspension cell filled with well-dispersed suspension. Switch the centrifuge on; typically this will initiate the timer to record the data.

9 Tests in duplicate and validation

9.1 Tests in duplicate

For tests in duplicate see ISO 13318-1.

9.2 Validation

For validation see ISO 13318-1. However, use reference materials with caution. Note that, where it is intended to apply an extinction coefficient correction, this is a function of the sample material as well as the particle size, and that the BCR and NIST reference materials are not all of the same chemical composition.

10 Calculation of results

10.1 General

The photocentrifuge measures the optical density of a suspension as a function of time from the start of the analysis. For the homogeneous mode, the mass percent undersize is obtained (if geometric optics apply) by normalizing the optical density, after correcting for radial dilution effects (see ISO 13318-1).

10.2 Calculation of particle size

Stokes diameters shall be calculated in accordance with ISO 13318-1.

10.3 Calculation of cumulative mass percentage

10.3.1 General

The light obscured by particles suspended in the path of a parallel beam of light is related to the concentration by the equation:

$$\ln\left(\frac{I_0}{I}\right) = G \sum_{i=0}^{St} n_i x_i^2 E_i \quad (1)$$

E_i is defined as the ratio of light obscured by a particle of diameter, x_i to the light which would be obscured if the laws of geometric optics were valid for the system under consideration. If, for a given system using monochromatic light, the ratio of particle diameter to the incident wavelength, λ , is greater than about 100, the value of E_i is essentially constant. However, for smaller ratios, E_i becomes a complex function of x_i/λ , (the relative refractive index of the particle with respect to that of the suspension medium), the shape of the particle and the geometry of the measuring device. Although fluctuations in E_i can be minimized by using a white light source in conjunction with a wide-angle acceptance detection receiver, the method is not absolute for particles whose diameter approximates to the wavelength of the incident light. Unless, therefore, the values of E_i corresponding to different diameters have either been calculated or measured experimentally for the system under test, results obtained by the method can only be regarded as having an unknown accuracy. The relationship between the time of sedimentation and the attenuation of the light beam is a characteristic of the sedimenting suspension and can be used for comparative investigations or quality control purposes.

10.3.2 Line-start technique (mass %)

For the line-start technique it is assumed that the particles present in the measurement zone at time t are of diameter x_{St} since the particles start from the same radius. The beam of light has a finite width and particles in the beam will constitute a size range proportional to x_{St} . The optical density, $D_t = -\lg(I_t/I_0)$, at time t is therefore proportional to $n_t x_{St}^3$ (for geometric optics, where E_i does not vary with x) since the range of summation of Equation (1) is proportional to $x_{St} t$.

A table is constructed showing variations of optical density with x_{St} at convenient time intervals. It is not necessary for the transmission data to be in absolute units and logarithms to base 10 can be used since the results are eventually to be expressed as mass percentages. Values of $\lg(I_0/I)$ are then plotted against x_{St} . If it is assumed that E_i and the particle shape coefficient G are constant, then this graph represents the mass frequency curve which can be integrated by areas to give the cumulative percentage by mass undersize data (see ISO 13318-1).

10.3.3 Homogeneous technique (mass %)

The photocentrifuge measures the optical density of a suspension against time from the start of analysis. For the homogeneous mode, normalizing the ordinate (optical density), after correcting for the radial dilution effect, and converting the abscissa to Stokes diameter generates a curve of optical density against Stokes diameter. Data in this form may be suitable for comparison purposes; otherwise corrections (e.g. Mie) may be used to correct for the breakdown in the laws of geometric optics with particle size. The measured surface concentration (nx^2) is determined using Equation (1). Correction is made for radial dilution (see ISO 13318-1) to give the frequency undersize by surface. The frequency undersize by mass is obtained by summing the product of frequency undersize by surface, $F(\text{surface})$, and x_{St} , and equating the total to 100 %.

11 Reporting of results

The report shall conform with the requirements set out in ISO 13318-1. Results shall be presented as Stokes diameter versus cumulative distribution by mass reported to the nearest 0,1 %. In the case of a plot, the diameters shall be placed on the abscissa and the cumulative mass percentage on the ordinate.

The test report shall contain the following information:

- a) reference to this part of ISO 13318, i.e. ISO 13318-2;
- b) name of the testing establishment;
- c) date of the test;
- d) unique report identification;
- e) operator's identity;
- f) instrument type used;
- g) mode of operation (e.g. line-start, homogeneous);
- h) sample identification;
- i) sample material;
- j) sample density (and mass, if applicable);
- k) suspending liquid, its temperature, its density, its viscosity and, where applicable, its volume;
- l) Mie correction applied or not applied;
- m) sample volume and concentration injected;
- n) dispersing agent and concentration of agent used;
- o) method of dispersion of the suspension, including dispersion time;

BS ISO 13318-2:2007

- p) buffer layer, and where applicable, the type and volume;
- q) centrifuge speed;
- r) light source;
- s) any other operation not specified in this part of ISO 13318 and which could have an influence on the results.

The following instrument characteristics, typically determined by the manufacturer and preprogrammed into the equipment software, may be optionally reported if available:

- measurement radius (M);
- inner disc radius (R);
- inner disc thickness (used to calculate vortex radius, S).

Annex A (informative)

Worked example

Worked example for a photocentrifuge analysis in line-start mode:

Reference to the International Standard	ISO 13318-2
Name of the testing establishment	MAL
Date of the test	2000-09-23
Unique report identification	Carbon 123
Operator's identity	JM
Instrument type used	Model P123
Operation mode	Line-start
Sample identification	C-B No.1
Sample material	Carbon black
Sample density	1 860 kg·m ⁻³
Spin liquid	Water
Temperature (spin fluid)	293,15 K
Liquid density	1 065 kg·m ⁻³
Liquid viscosity	2,10 mPa·s
Spin liquid volume	10 ml
Mie correction	Not applied in Table A.1. Applied in Figure A.2
Sample volume and concentration	0,2 ml, 0,25 % (mass per volume basis)
Dispersing agent	0,05 % (mass per volume) aqueous sodium polymetaphosphate solution
Dispersion method	1 min ultrasonic probe (75 W) in water-cooled jacketed container
Buffer layer	20/80 (volume per volume) glycerol/dispersing agent
Buffer layer volume	1 ml
Centrifuge speed	8 000 r·min ⁻¹
Measurement radius (<i>M</i>)	4,815 cm

BS ISO 13318-2:2007

Inner disc radius (<i>R</i>)	5,073 cm
Inner disc thickness	0,623 4 cm
Light source	LED 560 nm

Remarks:

$$\text{Vortex radius, } S = \sqrt{\frac{\pi(5,073)^2(0,623\ 4) - 10}{\pi 0,623\ 4}} = 4,542\ \text{cm}$$

Column 1 of Table A.1 gives the elapsed time from the start of the run and column 2 gives the measured optical density. These data are presented graphically in Figure A.1.

Table A.1 — Conversion of measured light into mass percentage undersize without Mie correction for a photocentrifuge operating in a line-start mode

Time min	Optical density $\lg(I_0/I)$	Stokes diameter x_{St} (μm)	Mass percentage undersize
33	0,000	0,089	0,0
32	0,000	0,091	0,0
31	0,001	0,092	0,0
30	0,002	0,094	0,0
29	0,003	0,095	0,0
28	0,004	0,097	0,0
27	0,006	0,099	0,0
26	0,007	0,101	0,0
25	0,008	0,103	0,0
24	0,011	0,105	0,1
23	0,012	0,107	0,1
22	0,015	0,110	0,1
21	0,019	0,112	0,2
20	0,022	0,115	0,2
19	0,025	0,118	0,3
18	0,029	0,121	0,3
17	0,032	0,125	0,4
16	0,037	0,128	0,6
15	0,045	0,133	0,7
14	0,054	0,137	0,9
13	0,062	0,142	1,2
12	0,073	0,148	1,6
11	0,087	0,155	2,0
10	0,103	0,162	2,7
9	0,123	0,171	3,6
8	0,146	0,182	5,0
7	0,174	0,194	6,9
6	0,210	0,210	9,8
5	0,249	0,230	14,5
4	0,287	0,257	22,1
3	0,320	0,296	35,5
2	0,279	0,363	59,4
1	0,166	0,513	83,2
0,5	0,083	0,726	100,0
0,25	0,039	1,027	100,0
0	0,000		

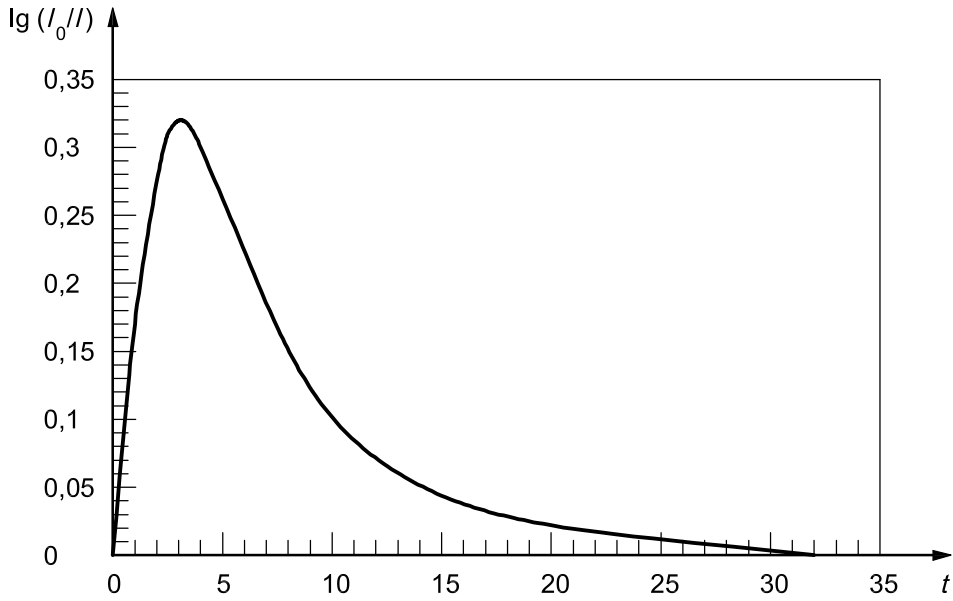
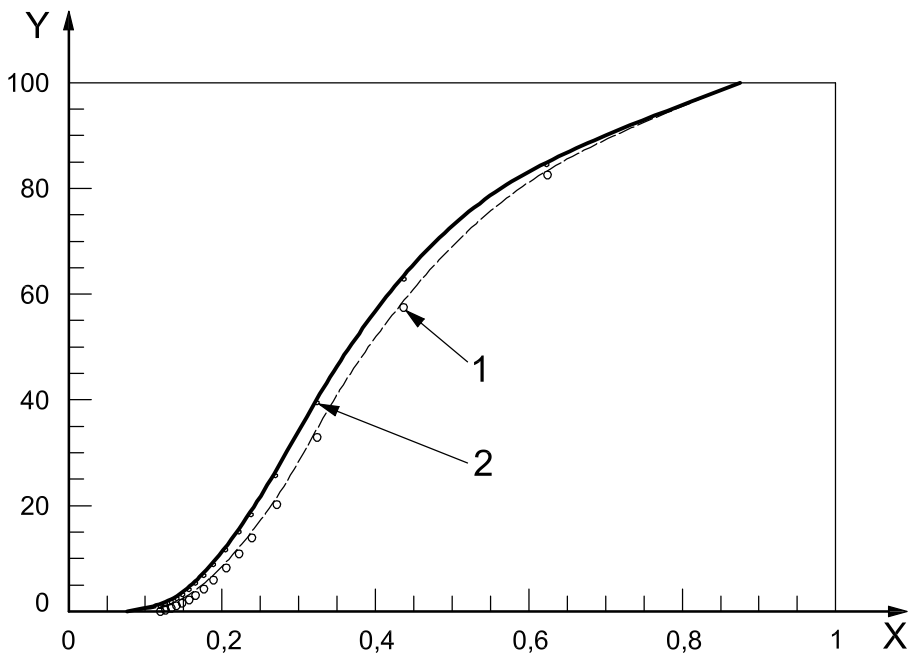

Figure A.1 — Raw data curve of changing optical density with time for a line-start disc photocentrifuge



- Key**
- X particle size, μm
 - Y mass percentage undersize
 - 1 uncorrected
 - 2 corrected

Figure A.2 — Cumulative mass percentage undersize by disc photocentrifuge in line-start mode showing effect of data corrected and uncorrected by Mie theory for light scatter

Annex B (informative)

Extinction curve, example for titanium dioxide

The raw data generated by a photocentrifuge is of light transmission versus time. These data are converted to a size distribution using instrument software. The software is typically based on equations presented in this part of ISO 13318. If no correction for light scatter is applied to the raw data then the generated size distribution is inaccurate but the resulting size distribution data may be used for comparing samples of the same material type. Correction curves may be based on theory (e.g. Mie theory) or by calibration. A typical curve for a white light source, Figure B.1, indicates that a 0,26 μm titanium dioxide particle cuts off six times as much light as a 0,13 μm particle thus, if these particles were present in equal amounts, neglecting the extinction correction would indicate that there were six times as many large particles as small ones.

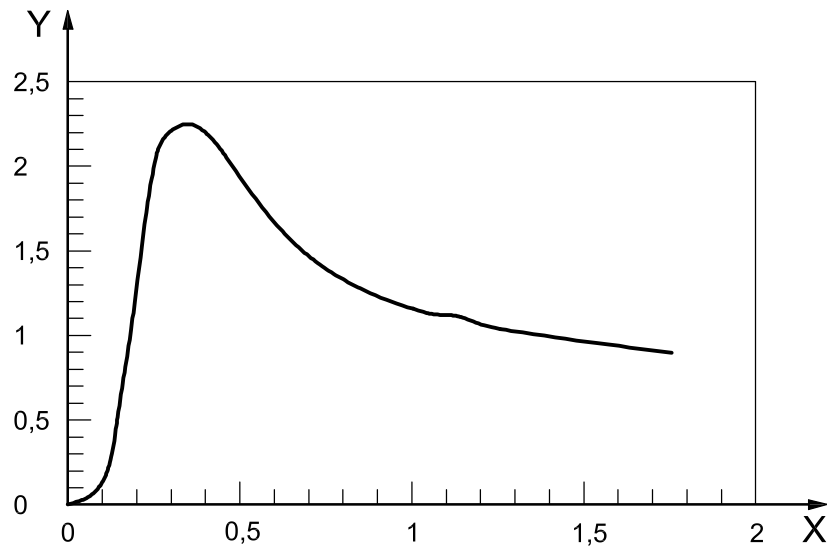

Key

- X particle size, micrometre
- Y extinction coefficient

Figure B.1 — Extinction curve for titanium dioxide using a white light source

Annex C
(informative)

Effect of radial dilution

Effect of radial dilution, demonstrated on a photo-centrifuge operating in the homogeneous mode (uncorrected for light scattering). See ISO 13318-1.

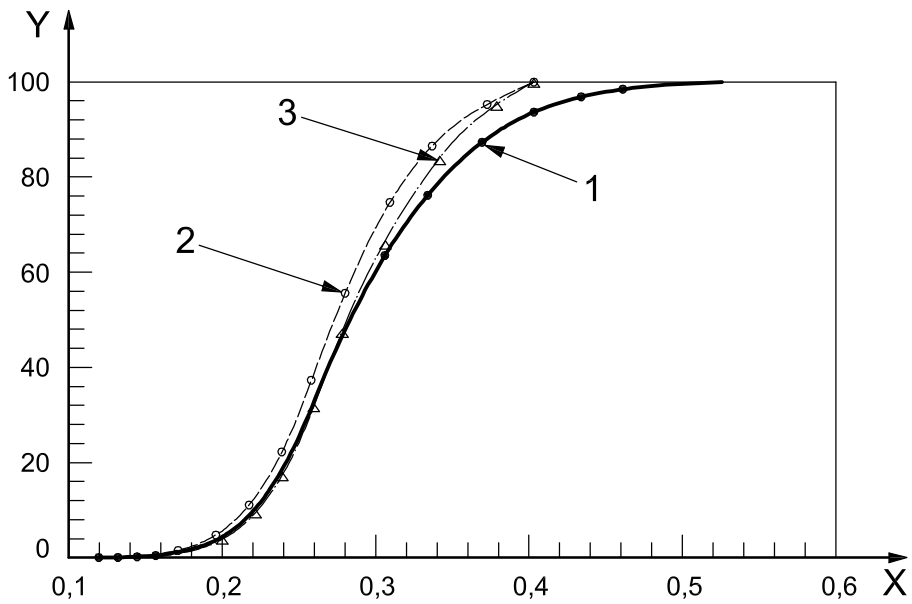

Key

X particle size, μm
Y percentage undersize

- 1 concentration
- 2 surface
- 3 mass

Figure C.1 — Effect of radial dilution on the measured concentration in a photo-centrifuge operating in the homogeneous mode (uncorrected for light scattering)

Bibliography

- [1] DETLOFF, T., SOBISCH, T. and LERCHE, D., Particle size distribution by space or time dependent extinction profiles obtained by analytical centrifugation. *Part. Part. Syst. Charact.* 2006, **23**(2), pp. 184-7

BSI — British Standards Institution

BSI is the independent national body responsible for preparing British Standards. It presents the UK view on standards in Europe and at the international level. It is incorporated by Royal Charter.

Revisions

British Standards are updated by amendment or revision. Users of British Standards should make sure that they possess the latest amendments or editions.

It is the constant aim of BSI to improve the quality of our products and services. We would be grateful if anyone finding an inaccuracy or ambiguity while using this British Standard would inform the Secretary of the technical committee responsible, the identity of which can be found on the inside front cover.
Tel: +44 (0)20 8996 9000. Fax: +44 (0)20 8996 7400.

BSI offers members an individual updating service called PLUS which ensures that subscribers automatically receive the latest editions of standards.

Buying standards

Orders for all BSI, international and foreign standards publications should be addressed to Customer Services. Tel: +44 (0)20 8996 9001.
Fax: +44 (0)20 8996 7001. Email: orders@bsi-global.com. Standards are also available from the BSI website at <http://www.bsi-global.com>.

In response to orders for international standards, it is BSI policy to supply the BSI implementation of those that have been published as British Standards, unless otherwise requested.

Information on standards

BSI provides a wide range of information on national, European and international standards through its Library and its Technical Help to Exporters Service. Various BSI electronic information services are also available which give details on all its products and services. Contact the Information Centre.
Tel: +44 (0)20 8996 7111. Fax: +44 (0)20 8996 7048. Email: info@bsi-global.com.

Subscribing members of BSI are kept up to date with standards developments and receive substantial discounts on the purchase price of standards. For details of these and other benefits contact Membership Administration.
Tel: +44 (0)20 8996 7002. Fax: +44 (0)20 8996 7001.
Email: membership@bsi-global.com.

Information regarding online access to British Standards via British Standards Online can be found at <http://www.bsi-global.com/bsonline>.

Further information about BSI is available on the BSI website at <http://www.bsi-global.com>.

Copyright

Copyright subsists in all BSI publications. BSI also holds the copyright, in the UK, of the publications of the international standardization bodies. Except as permitted under the Copyright, Designs and Patents Act 1988 no extract may be reproduced, stored in a retrieval system or transmitted in any form or by any means – electronic, photocopying, recording or otherwise – without prior written permission from BSI.

This does not preclude the free use, in the course of implementing the standard, of necessary details such as symbols, and size, type or grade designations. If these details are to be used for any other purpose than implementation then the prior written permission of BSI must be obtained.

Details and advice can be obtained from the Copyright & Licensing Manager.
Tel: +44 (0)20 8996 7070. Fax: +44 (0)20 8996 7553.
Email: copyright@bsi-global.com.