

Sensory analysis — Methods for assessing modifications to the flavour of foodstuffs due to packaging

ICS 67.240

**This document is now
PUBLIC**

National foreword

This British Standard reproduces verbatim ISO 13302:2003 and implements it as the UK national standard.

The UK participation in its preparation was entrusted to Technical Committee AW/12, Sensory analysis, which has the responsibility to:

- aid enquirers to understand the text;
- present to the responsible international/European committee any enquiries on the interpretation, or proposals for change, and keep the UK interests informed;
- monitor related international and European developments and promulgate them in the UK.

A list of organizations represented on this committee can be obtained on request to its secretary.

Cross-references

The British Standards which implement international publications referred to in this document may be found in the *BSI Catalogue* under the section entitled “International Standards Correspondence Index”, or by using the “Search” facility of the *BSI Electronic Catalogue* or of British Standards Online.

This publication does not purport to include all the necessary provisions of a contract. Users are responsible for its correct application.

Compliance with a British Standard does not of itself confer immunity from legal obligations.

Summary of pages

This document comprises a front cover, an inside front cover, the ISO title page, pages ii to v, a blank page, pages 1 to 26, an inside back cover and a back cover.

The BSI copyright notice displayed in this document indicates when the document was last issued.

Amendments issued since publication

Amd. No.	Date	Comments

This British Standard was published under the authority of the Standards Policy and Strategy Committee on 21 August 2003

© BSI 2003

This document is now
POOBLIC

INTERNATIONAL
STANDARD

ISO
13302

First edition
2003-08-01

**Sensory analysis — Methods for
assessing modifications to the flavour
of foodstuffs due to packaging**

*Analyse sensorielle — Méthodes pour évaluer les modifications de la
flaveur des aliments causées par l'emballage*

This document is now
POOBLIC



Reference number
ISO 13302:2003(E)

www.sinofood.com.cn



Contents

Page

Foreword	iv
Introduction	v
1 Scope	1
2 Normative references	1
3 Terms and definitions	2
4 Principle	3
4.1 Assessment of the inherent odour of the packaging material	3
4.2 Assessment of the effect of the packaging material on the flavour of the foodstuff	3
5 Foodstuff samples	3
5.1 General	3
5.2 Preparation of samples	5
6 Samples of packaging materials	5
6.1 General	5
6.2 Preparation of the packaging material samples for assessment of inherent odour	5
6.3 Preparation of the packaging material samples for assessment of the effect on the flavour of the foodstuff	6
7 Sensory tests	7
7.1 General test conditions	7
7.2 Assessors	8
7.3 Assessment of inherent odour of the packaging material	8
7.4 Assessment of the effect of packaging material on the flavour of the foodstuff	9
8 Analysis of the results	10
9 Test report	10
Annex A (informative) Guidelines for industrialists for assessing the product risk linked to the packaging	12
Annex B (informative) List of recommended containers	14
Annex C (informative) Examples of models for foodstuff simulant/temperature	16
Annex D (informative) Example of components originating from packaging suspected of being the cause of alterations in the sensory properties of foodstuffs	18
Annex E (informative) Example of application of the non-parametric Wilcoxon test for the interpretation of the results obtained by scoring test	19
Bibliography	26

This document is now
POUBLIC

Foreword

ISO (the International Organization for Standardization) is a worldwide federation of national standards bodies (ISO member bodies). The work of preparing International Standards is normally carried out through ISO technical committees. Each member body interested in a subject for which a technical committee has been established has the right to be represented on that committee. International organizations, governmental and non-governmental, in liaison with ISO, also take part in the work. ISO collaborates closely with the International Electrotechnical Commission (IEC) on all matters of electrotechnical standardization.

International Standards are drafted in accordance with the rules given in the ISO/IEC Directives, Part 2.

The main task of technical committees is to prepare International Standards. Draft International Standards adopted by the technical committees are circulated to the member bodies for voting. Publication as an International Standard requires approval by at least 75 % of the member bodies casting a vote.

Attention is drawn to the possibility that some of the elements of this document may be the subject of patent rights. ISO shall not be held responsible for identifying any or all such patent rights.

ISO 13302 was prepared by Technical Committee ISO/TC 34, *Food products*, Subcommittee SC 12, *Sensory analysis*.

This document is now
POOBLIC

Introduction

It is necessary to prevent materials intended for the packaging of foodstuffs from being the cause of unwanted alterations in odour or flavour. Likewise, it is necessary to take into account the storage conditions of the foodstuffs once they are packed since this can also be one of the causes of modifications to odour or flavour.

Certain types of foodstuff are particularly susceptible to flavour modifications due to packaging materials (e.g. fatty or powdered products having a large area in contact with the packaging). In particular, the packaging material can contaminate the product by transfer. This transfer can occur by direct contact with the packaging material or, indirectly, by means of the atmosphere created between the packaging and the product. Foreign odours or flavours can also come from the inner or outer layers of the packaging material.

The packaging material can also absorb compounds from foodstuffs and cause modifications of flavours.

Food industries should ensure that the packaging they use is the best possible choice with respect to their products. This is why they must have at their disposal methods which allow them to ascertain that the flavour of the foodstuffs is not significantly modified under certain storage conditions.

Compounds transferred from packaging materials and responsible for undesired effects on the flavour of food products are usually in very low quantities, often below the detection limits of the analytical techniques, or simply the compounds responsible for the changes in flavour have not been identified. Thus, it is necessary to evaluate the sensory properties of packaging materials.

This International Standard describes two complementary tests which are not mutually exclusive:

- assessment of the inherent odour of the packaging material under test (odour test);
- assessment of the change of flavour of a foodstuff after direct or indirect contact with the packaging material under test in actual conditions or in simulated conditions (contact test).

This International Standard was developed by a group composed of sensory analysis experts and experts from the packaging sector and is based on their experience.

This document is now
POOBLIC

www.sinofood.com.cn



Sensory analysis — Methods for assessing modifications to the flavour of foodstuffs due to packaging

1 Scope

This International Standard describes methods for assessing the changes caused by packaging to the sensory attributes of foodstuffs or their simulants.

The methodology can be used as initial selection to assess a suitable packaging material or as subsequent acceptability screening of individual batches/production run (see Annex A).

This International Standard is applicable to all materials usable for packaging foodstuffs (e.g. paper, cardboard, plastic, foils, wood). Moreover, the scope can be extended to any objects intended to come into contact with foodstuffs (e.g. kitchen utensils, coatings, leaflets, or parts of equipment such as seals or piping) with the aim of controlling food compatibility from a sensory point of view according to the legislation in force.

2 Normative references

The following referenced documents are indispensable for the application of this document. For dated references, only the edition cited applies. For undated references, the latest edition of the referenced document (including any amendments) applies.

ISO 483:1988, *Plastics — Small enclosures for conditioning and testing using aqueous solutions to maintain relative humidity at constant value*

ISO 4120, *Sensory analysis — Methodology — Triangle test*

ISO 5492, *Sensory analysis — Vocabulary*

ISO 5495:1983, *Sensory analysis — Methodology — Paired comparison test*

ISO 6564, *Sensory analysis — Methodology — Flavour profile methods*

ISO 8586-1, *Sensory analysis — General guidance for the selection, training and monitoring of assessors — Part 1: Selected assessors*

ISO 8586-2, *Sensory analysis — General guidance for the selection, training and monitoring of assessors — Part 2: Experts*

ISO 8587:1988, *Sensory analysis — Methodology — Ranking*

ISO 8589, *Sensory analysis — General guidance for the design of test rooms*

ISO 11035, *Sensory analysis — Identification and selection of descriptors for establishing a sensory profile by multidimensional approach*

is — Methodology — Duo-trio test

is — Methodology — General guidance for establishing a sensory profile

This document is now
POOBLIC

3 Terms and definitions

For the purposes of this document, the terms and definitions given in ISO 5492 and the following apply.

3.1 packaging
object intended for wrapping or containing, temporarily, a product or series of products during handling, transportation, storage or presentation, with a view to preserving, protecting or facilitating these operations

NOTE This International Standard covers packaging coming into direct contact with foodstuffs.

3.2 new packaging
any packaging in which at least one of the constituent elements (e.g. nature of the material, adhesives, inks, solvents, varnishes) is new or has been modified

3.3 odour
sensory attribute perceptible by the olfactory organ on sniffing certain volatile substances

3.4 flavour
complex set of olfactory, gustatory and trigeminal sensations perceived during the course of the tasting

NOTE The flavour can be influenced by somaesthetic (tactile, thermal, algescic and/or kinesthetic) impressions.

3.5 taint
flavour which is foreign to the foodstuff

3.6 off-flavour
atypical flavour of the foodstuff, often associated with the deterioration of the foodstuff

3.7 reference material
packaging material which does not interfere with the sensory properties of a product

NOTE The reference material could be an approved packaging that already exists which complies with the legislation in force.

3.8 assessor
(sensory) any person taking part in a sensory test

NOTE A naïve assessor is a person who does not meet any particular criterion. An initiated assessor is a person who has already participated in a sensory test.

3.9 selected assessor
(sensory) assessor chosen for his/her ability to perform a sensory test

3.10 expert
(general sense) a person who, through knowledge or experience, has competence to give an opinion in the fields about which he/she is consulted

There are two types of expert, the "expert assessor" and the "specialized expert assessor",

This document is now
POOBLIC

3.10.1**expert assessor**

selected assessor with a high degree of sensory sensitivity and trained in the use of sensory analysis methods and who is able to make consistent and repeatable sensory assessments of various products

3.10.2**specialized expert assessor**

expert assessor who has additional experience as a specialist in the product and/or process and/or marketing, and who is able to perform sensory analysis of the product and to evaluate or predict effects of variations relating to raw materials, recipes, processing, storage, ageing, etc.

4 Principle**4.1 Assessment of the inherent odour of the packaging material**

The packaging material under test is stored in a container under controlled conditions.

The odour of the atmosphere developed upon confinement is assessed by means of sensory analysis methods.

4.2 Assessment of the effect of the packaging material on the flavour of the foodstuff

The foodstuff and the packaging material under test, with direct or indirect contact, are stored in a container under controlled conditions.

The flavour changes of the foodstuff are assessed by means of sensory analysis methods.

5 Foodstuff samples**5.1 General**

CAUTION — Hygienic and safety requirements related to the products used shall be followed.

When possible, use the actual foodstuff, method of packing and storage conditions (temperatures, contact time, etc.) for the tests. This is highly recommended for tests performed at the development level.

For repeated tests with a panel, use, if possible, the same foodstuff references (same product and same trade name). In the other cases, use a similar foodstuff which approximates the real product.

It is sometimes necessary to decrease the leading time or to use a model foodstuff when actual foodstuffs are not known and/or actual storage conditions are not achievable.

To date, the sole validated model concerns offset printed paper/cardboard used for chocolate products:

- grated milk chocolate
- relative humidity, 75 %,
- temperature, 23 °C ± 2 °C,
- duration, 48 h (adapted from the Robinson test ^[14]).

The set up is shown in Figure 1. The interpretation of this model is limited because it does not take into account the effect of the foodstuff mass to the packaging surface.

dated models are given in Annex C.

This document is now
PUBLIC

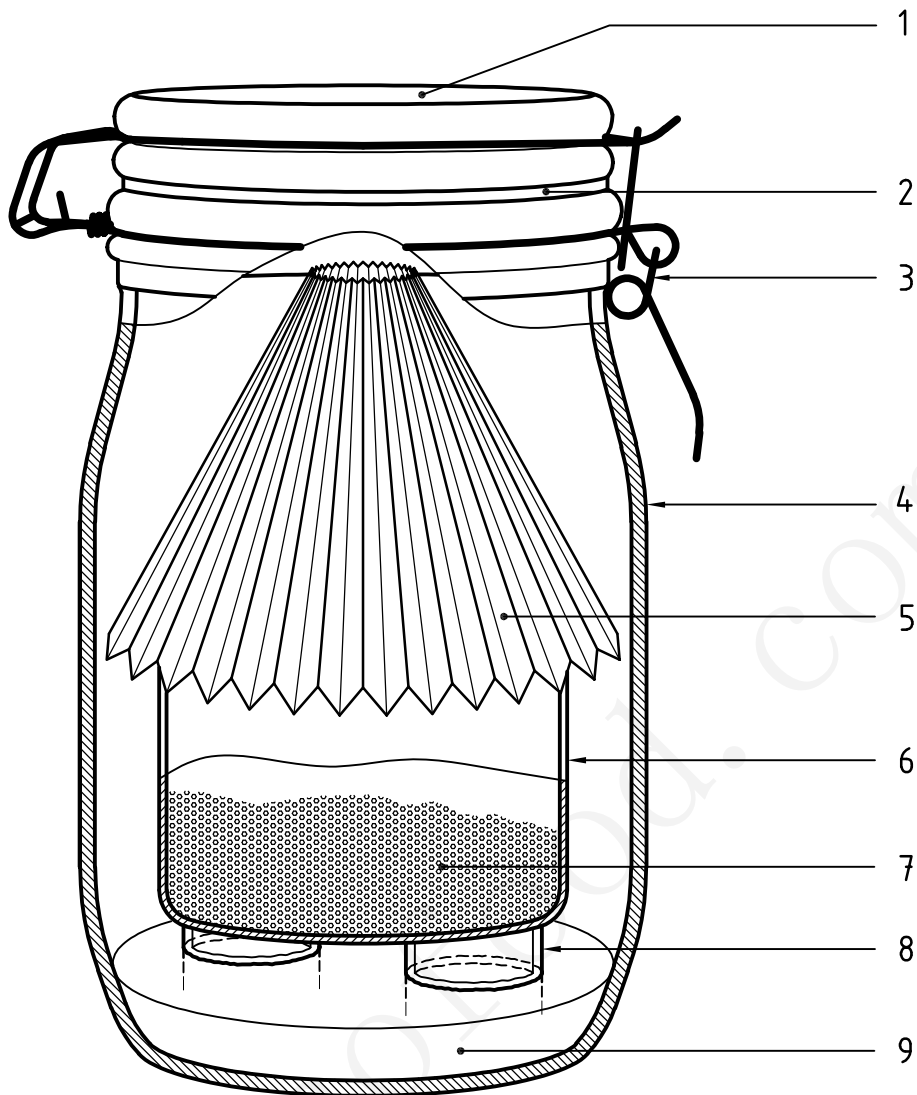

Key

- | | |
|--|--|
| 1 glass lid | 6 glass crystallizing dish (diameter 8 cm) |
| 2 polytetrafluoroethylene [Teflon® ¹⁾] | 7 grated milk chocolate (25 g) |
| 3 metal clip | 8 glass rings |
| 4 glass jar (1 000 ml) | 9 saturated NaCl solution (60 ml) |
| 5 packaging material under test (6 dm ²) | |

Figure 1 — Set-up for testing paper/cardboard

the product available commercially. This information is given for the convenience of users and does not constitute an endorsement by ISO of this product. Equivalent products may be used to obtain the same results.



5.2 Preparation of samples

Provide the amount of sample material needed for each assessor.

The quantity varies according to the foodstuff concerned and is, in general,

- 4 g to 30 g for solid foodstuffs, and
- 15 ml to 50 ml for liquid foodstuffs.

Adapt the number of containers to the panel size (see 6.3).

6 Samples of packaging materials

6.1 General

Prior to conducting the tests, preserve the packaging materials under cold conditions (at approximately 5 °C) and wrapped in an uncoated sheet of aluminium foil or in an airtight glass container.

For sheet or film type materials, sample representative material specimens and eliminate the outer layers (e.g. initial turns of a roll, first and last sheets of a pile).

6.2 Preparation of the packaging material samples for assessment of inherent odour

6.2.1 Test conditions

Use actual conditions if they are known.

If they are not known, proceed as follows.

- a) For flexible, single-layered materials, the material surface area/container volume ratio recommended is 6 dm²/l. In the case of printed material, care should be taken to maintain about the same ratio between the printed and unprinted surfaces in the section to be tested.
- b) With laminated or multilayered materials with essential differences between the surfaces being separated by a practically impermeable inner layer, especially in the case of printed samples, the test should be carried out on one side, namely, on the side designed for contact with the packaged food product. Produce shape tetrahedrons or bags to test their interior (e.g. 6 dm²). Bags may be either sealed (with respect to sealing conditions recommended by industrialists) or closed with adhesives which will not impart odour to the interior.
- c) Rigid materials may be cut into pieces provided that no modification to the structure of the material occurs.

It is important always to follow the same procedure once it has been selected.

6.2.2 Method

Where possible, for each sample, provide one container for each of the assessors taking part in the test (see Annex B for recommended containers).

Insert into each container the appropriate surface area of packaging material.

If there is a visual difference, make sure that the material placed in the container is not visible from the outside (e.g. cover the container with aluminium foil).

Store in a dark place for 24 h at 23 °C ± 2 °C or, if a rough evaluation is needed, 1 h at

This document is now
POOBLIC

6.2.3 Reference sample

If a reference sample is needed, use the reference material by treating it in the same way as the test material. The reference packaging material used in this case is a material that does not interfere with the sensory properties of the foodstuff (3.7).

If no reference packaging material exists or optimum quality conditions are desired, it is possible to prepare the reference sample without the packaging, by simply using the same container type without any packaging material.

6.3 Preparation of the packaging material samples for assessment of the effect on the flavour of the foodstuff

6.3.1 Simulation tests with direct contact

Whenever possible, use actual conditions. If actual conditions are not known or not achievable, use simulation tests as described below. See Annex C for use of simulants.

a) Liquid foodstuffs

See Table 1 for the recommended conditions of contact as a function of the different materials to be tested. Applicable conditions for each type of material are represented by a grey area.

The surface area of material in contact/volume of test foodstuff ratio, except for special conditions (e.g. migration cell 2 dm² per 200 ml), shall be 6 dm² per litre of substance.

b) Solid foodstuffs

For materials in sheet or film form, make a sandwich with 2 dm² of packaging material in contact with a 1 cm layer of the test foodstuff (cut strips from the film and interlace with the foodstuff). Provide a sufficient quantity of the product for the assessors.

For fillable objects, fill up to the normal capacity and cover the objects over with a glass Petri dish cover.

Table 1 — Recommended conditions of contact

Material	Immersion	Cell ^a	Bag	Filling
Unprinted single-layer materials	$t^b > 0,5 \text{ mm}$, 3 dm ² /l $t < 0,5 \text{ mm}$, 6 dm ² /l ^c			
Printed single-layer or multilayer materials				
Fillable objects				6 dm ² /l ^c
Plugs and closing systems				
^a Migration cell type (one single side in contact). ^b t is the thickness. ^c See reference [17] for details.				

6.3.2 Simulation tests with indirect contact

Depending on the contact temperature, choose an appropriate solution of salts according to the provisions of ISO 483 that allows a constant relative humidity at a given temperature equal to the actual relative humidity. If the actual relative humidity is not known, use a saturated aqueous solution of sodium chloride (NaCl) that allows a relative humidity of 75 % (see Table 3 of ISO 483:1988). Pour the salt solution into the 1 000 ml container (glass jar or desiccators) into which the Raschig rings are laid out (see Annex B).

Introduce a Petri dish containing 15 g of test foodstuff in the container and place it on the Raschig rings.

Arrange the material (3 dm² or 6 dm²) around the Petri dish.

Adapt the number of containers to the panel size.

6.3.3 Reference samples

If a reference sample is needed, prepare it in the same way as the test sample and keep under the same conditions. The reference packaging material used in this case is a material that does not interfere with the sensory properties of the foodstuff (3.7).

If no reference packaging material exists or optimum quality conditions are desired, it is possible to prepare the reference sample without the packaging for tests with indirect contact or by using glass packaging for tests with direct contact (see Annex B).

7 Sensory tests

7.1 General test conditions

It is recommended that the tests be conducted in a room which complies with ISO 8589. At a minimum, odour-free rooms are required for preparing the food and packaging samples and for performing the tests.

The containers for the foodstuffs and the packaging materials shall not have any influence on the test results and shall be totally odourless. A list of recommended containers is given in Annex B.

The equipment used (e.g. cleaning products, adhesive tape, pens) shall not transmit any odour.

In order to prevent the assessors from visually recognizing the materials, it is possible to conduct the test in dim light or under modified lighting conditions.

Preferably give the samples random three-figure code numbers.

For the order of presentation of the samples for differentiation tests, refer to the corresponding International Standards.

For the order of presentation for scoring on a scale tests, give to a randomly chosen half of the group the samples in the order "test sample" then "reference sample", and to the other half of the group in the order "reference sample" then "test sample".

For situations where several different tests are performed during the same session, the order of presentation of the samples shall, as for all sensory tests, be different from one assessor to another. The ideal is that, for the whole group, there is a balance for the position (each product being presented the same number of times to each possible position) and for the sequence of two consecutive products (each product being preceded the same number of times by each of the other samples) (see [10]).

7.2 Assessors

7.2.1 Qualification of the assessors

The conditions under which the assessors shall be recruited and selected are given in ISO 8586-1 and ISO 8586-2.

Since the defects due to the packaging are generally ones which can be perceived by the olfactive organ, ensure in particular that the candidates are not suffering from allergies or from illnesses which affect the sense of smell (e.g. hay fever, sinusitis, chronic bronchitis).

As specific anosmia could exist, it may prove to be worthwhile to assess the sensitivity of the candidates to the compounds transmitted by the type of packaging being studied and already known as being responsible for sensory defects (see Annex D), and to eliminate assessors who have low sensitivity.

Use the selection and training methods that are specific to the types of tests which the assessor will carry out, namely a differentiation test, scoring on a scale test or descriptive test.

In both cases, it is advisable to ascertain

- the availability of the assessors,
- their interest and motivation, and
- their capacity to concentrate.

If the assessors are to carry out descriptive tests (sensory profiles), it is advisable to check their ability to describe what they perceive (see ISO 6564).

The members of the panel shall be accustomed to assess the foodstuffs being tested, in order to be able to detect flavour modifications.

7.2.2 Number of assessors

To define the number of assessors, refer to ISO 4120 or ISO 5495 for difference tests, to ISO 13299 for qualitative or quantitative description, or to the tables given in reference [9].

The number of assessors shall be chosen as a function of the type and purpose of the test. It is necessary to be aware of the fact that the lower the number of assessors, the higher the beta risk. Thus, it can be concluded that there is no difference where in fact there is one. The danger of accepting an inappropriate packaging is therefore greater. More assessors are required, to this end, when assessing whether the packaging causes a taint.

7.3 Assessment of inherent odour of the packaging material

7.3.1 Sensory test

To determine whether or not the assessors can detect a difference of odour between the “test” sample and the “reference” sample, several tests are described below. It is recommended to adopt one of them and then to use it for all cases where it is necessary to answer the same type of question.

- a) **Paired comparison test** on the overall intensity of odour in accordance with the procedure described in ISO 5495. In this case, the assessors are asked the question “*Which sample has the stronger odour?*”

th the procedure described in ISO 4120.

reference (the reference being the reference sample). If the packaging has received by the assessors, they may be asked to describe it.

- d) **Ranking test** when more than two samples are being compared according to the method given in ISO 8587, if the attribute is known.
- e) **Scoring tests** if it is wished to determine the difference of intensity of odours. The intensity of the odour of the sample(s) is scored on a response scale (e.g. 5-point scale defined as follows: 0 no perceptible odour; 1 just perceptible odour; 2 moderate odour; 3 strong odour; 4 very strong odour. The example given in Annex E has a 7-point scale (0 no taint; 6 pronounced taint). The target is defined by the confidence level expected. One of the samples may be a hidden reference: in this case, the values obtained for the “test” sample will be compared to those obtained for the “hidden reference” to permit statistical analysis of the results. If the assessors detect a different odour, they may be asked to describe it.

It is recommended that scoring tests be used with trained panels.

For the quantified description of perceived odours, carry out a sensory profile which is used to determine accurately the characteristics of the odour of the packaging. This can provide details on the origin of these odours (ink, adhesive, etc.). Refer to ISO 6564, ISO 11035 and ISO 13299.

7.3.2 Procedure

After the storage phase, test the odour of the atmosphere developed upon confinement with the packaging material or in the packaging material.

Assess the odour of the samples immediately after opening the jars, bottles or bags.

For carrying out the odour test, each assessor proceeds in the following manner:

- with jars or bottles: smell immediately after removing the emery-ground cover and replace it immediately;
- with bags: cut off one of the corners of the bag, then immediately smell the area just above this opening while pressing the bag.

7.4 Assessment of the effect of packaging material on the flavour of the foodstuff

7.4.1 Sensory test

Different methods may be used to determine the modification of flavour in products, including those due to interaction between the product and packaging or the scalping effect. It is recommended to adopt one of them and then to use it for all cases where it is necessary to answer the same type of question.

- a) **Paired comparison test** on the overall intensity of taint in accordance with the procedure described in ISO 5495. In this case, the assessors are asked the question “Which sample is tainted?”
- b) **Triangle test** in accordance with the procedure described in ISO 4120.
- c) **Duo trio test with constant reference** (the reference being the reference sample) according to the method described in ISO 10399.
- d) **Ranking test** when more than two samples are being compared, according to the method given in ISO 8587, if the taint is known.
- e) **Scoring tests** if it is wished to determine the difference of intensity of taints. The intensity of the taint of the sample(s) is scored on response scales similar to those described in 7.3.1. One of the samples can be a hidden reference. In this case, the values obtained for the “test” sample will be compared to those obtained for the “hidden reference” to permit statistical analysis of the results. If the assessors detect a difference, they may be asked to describe it.

Scoring tests be used with trained panels.

This document is now
PUBLIC

For the quantified description of perceived taints, carry out a sensory profile so as to be able to determine accurately the influence of the packaging on the sensory attributes of the packaged products. Refer to ISO 6564, ISO 11035 and ISO 13299.

7.4.2 Procedure

Make up a "test" batch and a "reference" batch by collecting samples of foodstuffs originating from the various contact vessels at the end of the chosen contact period.

Divide up the liquid test foodstuff samples into glass tumblers.

Divide up the solid test foodstuff samples into Petri dishes or white ceramic plates.

Ensure the homogeneity of the test sample by, for example, mixing grated or crushed food to obtain a representative sample.

During the distribution to the assessors, ensure that the foodstuff samples are placed in covered containers in order to prevent odours from dispersing into the atmosphere.

8 Analysis of the results

For the paired comparison test, analyse the results according to Table 2 of ISO 5495:1983.

For the triangle test, analyse the results according to ISO 4120.

For the ranking test, analyse the results according to Tables 3 and 4 of ISO 8587:1988.

For the scoring test, a non-parametric Wilcoxon rank signed test may be used (see example in Annex E). If the scale is linear (scale used with trained panels), it is possible to handle data by a Student test.

Understanding the nature of the odour or flavour and its influence on the foodstuff is linked to the experience of the company and to the results obtained during the test to determine the effect of the material on the flavour of the foodstuff. Correlations between the odour intensity, the type of the odour, and the influence on the sensory attributes of the products are useful when making a decision on the acceptance of packaging. See Annex A for guidelines.

9 Test report

The test report shall give the following information:

- name of body which conducted the tests;
- reference to this International Standard;
- identification of the material sample of the packaging to be tested;
- identification of the reference material of the packaging;
- foodstuff intended to enter into contact with the material (if known)
- foodstuff used for the test;

: sample(s);

- for contact tests: conditions of contact between the material and the test foodstuff and, in particular, the nature of the contact (direct or indirect), practical details of the contact, duration, temperature and relative humidity during the contact phase;
- type of sensory test carried out;
- number and qualification of assessors;
- test results;
- recommendations relating to the acceptance of the batch or of the new packaging, if required.

www.sinofood.com.cn

py: Uni of Science & Technology User, University of Science & Tech, Sat Sep 17 03:31:01 BST 2005, Uncontrolled Copy, (c) BSI



Annex A (informative)

Guidelines for industrialists for assessing the product risk linked to the packaging

A.1 Evaluation of a new packaging in development laboratory

The effect of the packaging material on the flavour of foodstuffs is assessed using new packaging. Tests performed at this level therefore *necessitate contact between the product and the packaging* to determine whether the packaging conforms, from a sensory aspect, to the use that will be made of it.

Assessment of the odour of the packaging is carried out in parallel.

Since the occurrence of taints in the product placed in contact with the packaging can be predicted by the results of the tests on the odour of the packaging, tests performed subsequently during acceptance control could focus simply on the odour of the packaging. If this is not the case, a quick test of the odour during acceptance control will not suffice and contact tests should be carried out. Tests performed at development level will therefore also determine the type of test which could be used subsequently for acceptance control of the packaging. Table A.1 lists these decision rules.

Table A.1 — Decision rules

Results of odour test	Results of contact test	
	No modification of foodstuff flavour	Modification of foodstuff flavour
Odour of packaging material not perceptible	PACKAGING APPROPRIATE <i>Further batches of the assessed material shall be odourless.</i>	PACKAGING NOT APPROPRIATE <i>Correlation odour/flavour modification not possible.</i> <i>Define component responsible for the flavour modification if possible before further development.</i>
Odour of packaging material perceptible	PACKAGING APPROPRIATE <i>Odour intensity upper limit for further batches of the assessed material is defined.</i>	PACKAGING NOT APPROPRIATE <i>Reduce odour level and redo contact tests and odour tests.</i>

A.2 Routine control: Assessment of risk on acceptance of the packaging

Routine controls in production are carried out as a function of the results of the development tests: two cases can be met.

a) Case 1: Flavour modification is linked to the odour of the packaging

Only the odour of the packaging needs to be assessed. The intensity of the odour should be equal to or lower than the reference point defined during the development test.

If the odour intensity is higher than the reference point, a contact test should be initiated again to check acceptable for the product. This odour level is defined as the upper limit if the modified, otherwise the packaging is rejected.

This document is now
POOBLIC

b) Case 2: Flavour modification is not linked to the odour of the packaging

In this case, the packaging exhibits no odour. However, flavour modification occurs (e.g. when polystyrene come into contact with foodstuff, the monomer styrene may be released and may taint the product).

The odour test does not forecast the impact on the finished product. Contact tests should be carried out for each new production run.

www.sinofood.com.cn

This document is now
POOBLIC

Annex B (informative)

List of recommended containers

B.1 Containers for placing the material in contact with the foodstuff

The following are suitable:

- a) **jars or desiccators**, made of opaque glass having a capacity of 1 000 ml, without rubber or sealing grease with emery-ground cover;
- b) **Petri dishes**, made of glass, approximately 150 mm × 30 mm;
- c) **ground necked tubes and bottles**, made of opaque glass, having a capacity of 100 ml, 200 ml, 250 ml, 300 ml, 400 ml or 500 ml;
- d) **Raschig ring**, generally of 2 cm to 3 cm in diameter and of 2 cm to 3 cm in height, or a ring on feet, made of inert material [to isolate the packaging from the dishes in which is placed the foodstuff (for indirect contact)];
- e) **migration cells** (device which allows contact with only one side of the material), made of stainless steel, having a volume of 200 cm³ and a contact surface area of 2 dm² (with inert join) (see Figure B.1).

B.2 Containers for performing sensory tests on the foodstuffs

The following are suitable:

- a) **Petri dishes**, made of glass, approximately 80 mm × 20 mm;
- b) **tumblers**, made of glass, having an approximate capacity of 120 ml, possibly covered with a Petri dish cover.

B.3 Containers for assessing the odour of the packaging material

The following are suitable:

- a) **jars or desiccators**, made of opaque glass, having a capacity of 1 000 ml, without rubber or sealing grease, but with emery ground cover;
- b) **ground necked tubes and bottles**, made of opaque glass, having a capacity of 100 ml, 200 ml, 250 ml, 300 ml, 400 ml or 500 ml.
- c) **bags**, made with an approved odourless material of a consistent surface (from 4 dm² to 6 dm²), preferably with a square shape. Make sure that the closing device (sealing) causes no odour (e.g. use a paper clip).

This document is now
POOBLIC

Dimensions in millimetres

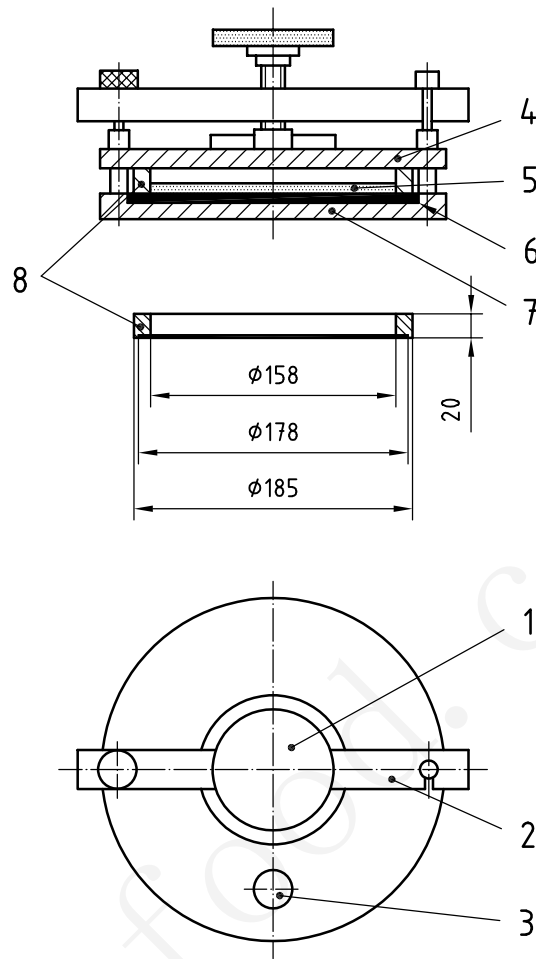

Key

- | | |
|---------------|---------------------------------|
| 1 clamp screw | 5 food product (or simulant) |
| 2 clamp bar | 6 packaging material under test |
| 3 filler plug | 7 base plate |
| 4 lid | 8 sealing ring |

Figure B.1 — Migration cell



Annex C (informative)

Examples of models for foodstuff simulant/temperature

When actual conditions are not known or not achievable, a foodstuff simulant and conventional temperature can be used for contact tests.

Table C.1 lists examples of product/temperature models.

Table C.1 — Examples of product/temperature models

Type of foodstuff	Suggested foodstuff simulant	Chamber contact temperature
Unfermented dairy products, thickened milks	Homogenized whole milk	10 °C ± 2 °C
Dairy products (yoghurts, soft white cheese)	Water + 0,2 g/l lactic acid	10 °C ± 2 °C
Liquid fatty products	Refined vegetable oil	23 °C ± 2 °C
Meats and meat-based processed products (cooked dishes) Cheese and butter	Margarine or butter	10 °C ± 2 °C
Dry biscuits and dry products with low fat content	Crushed rusks	23 °C ± 2 °C
Products containing more than 35 % water (fruits, vegetables, beverages)	Water + citric acid + sugar (to be mixed in the same proportion as in the product to be simulated)	23 °C ± 2 °C
Alcoholic drinks	Ethanol: 60 ml Glycerol: 10 mg Water to make up 1 l	23 °C ± 2 °C
Chocolate, chocolate [by-] products and fatty biscuits Dry fatty products	Grated milk chocolate	23 °C ± 2 °C
Water	Odourless water	23 °C ± 2 °C

For those products which undergo a heat treatment within their packaging, bring the foodstuff up to 80 °C ± 5 °C, if possible within the limits of the type of heating and the temperature rise and fall curves.

For deep-frozen products, store the foodstuff at -10 °C ± 2 °C.

The relative humidity should be representative of the actual or desired conditions (generally between 50 % and 75 %).

The model products used should have as neutral a taste and odour as possible for the range of products under consideration.

, glycerol, citric acid) should be food grade.

This document is now
POOBLIC

The contact times recommended for test purposes, depending on the expected storage times, are as follows:

- short preservation time (less than 1 month): 48 h;
- average preservation time (from 1 to 9 months): 10 days;
- long preservation time (9 months and over): 30 days.

A contact period of 48 h may be used for conducting faster tests as an initial approach.

The contact period should never be less than 48 h.



Annex D (informative)

Example of components originating from packaging suspected of being the cause of alterations in the sensory properties of foodstuffs

The following components are suspect:

- a) acetaldehyde, in poly(ethylene terephthalate) and polyethylene;
- b) styrene or ethyl benzene, in polystyrene;
- c) residual solvents from printing ink and varnish of printed paper and plastics
 - isopropanol,
 - ethyl acetate,
 - methyl ethyl ketone,
 - propyl acetate,
 - 1-methoxyl-2-propanol;
- d) dibutyl adipate (decomposition product of bis(2-ethylene hexyl)adipate or DOA plastifier of poly(vinyl chloride));
- e) volatile nitrosamines in rubber.

See also reference [11].

Annex E (informative)

Example of application of the non-parametric Wilcoxon test for the interpretation of the results obtained by scoring test

Twelve assessors have estimated the odour intensity of a reference material and of a test material on a 7-point discrete scale (0 = no odour, 6 = pronounced odour). The results are given in Table E.1. The difference in intensities (DI) is calculated for each assessor. The absolute values of differences are ranked in ascending order and zero values are discarded.

Table E.1 — Results of scoring test

Assessor	A	B	C	D	E	F	G	H	I	J	K	L
Reference product	0	1	2	1	2	1	2	0	0	1	1	2
Test product	1	3	2	5	4	1	1	3	4	2	1	1
DI reference test	-1	-2	0	-4	-2	0	+1	-3	-4	-1	0	+1
Rank DI	2,5	5,5	—	8,5	5,5	—	2,5	7	8,5	2,5	—	2,5

In the event of equal placings, proceed in the following manner.

Count the number of times the same DI value is obtained, examine in which positions they are located and calculate the average rank as follows.

- There is the absolute value 1 for four assessors (A, G, J and L) which thus occupy the positions 1, 2, 3 and 4. The average rank of 1, 2, 3 and 4 is $(1 + 2 + 3 + 4)/4 = 2,5$. This value is therefore taken for the rank of the assessors A, G, J and L.
- There are two assessors for whom the absolute value of DI is 2. The average rank is thus $(5 + 6)/2 = 5,5$.
- There is one assessor for whom the absolute value of DI is 3. The rank for assessor H is 7.
- There are two assessors for whom the absolute value of DI is 4. The average rank is thus $(8 + 9)/2 = 8,5$.

Calculate

- the sum of the ranks of the negative DI values, W_- , and
- the sum of the ranks of the positive DI values, W_+ :

$$W_- = 2,5 + 5,5 + 8,5 + 5,5 + 7 + 8,5 + 2,5 = 40$$

$$W_+ = 2,5 + 2,5 = 5$$

Calculate the total number of assessors (N) minus the number of zero DI values. In this example N is 9.

Check that

/2

45.

Table E.2 outlines, in the one-tailed test, the probability for a given N , that W_+ is greater than or equal to c .

The one-tailed test should be used when the experimenter knows the difference between the reference sample and the test sample before collecting the data. In this case, if he expects that the test sample to have a less intense odour than the reference sample, he will calculate DI as the odour intensity of the reference minus the odour intensity of the test, and will take W_+ to compare the tabulated values.

If the experimenter does not know whether the difference is positive or negative, the alternative hypothesis H_1 is that "the odour intensity of the reference sample and that of the test sample are different". He should then consider the probability corresponding to $W = \sup(W^-, W_+)$ and multiply by 2.

In the example, the experimenter does not know whether the difference is positive or negative, so the alternative hypothesis is therefore H_1 : the odour intensity of the test sample and the odour intensity of the reference sample are different.

Table E.2 gives for $N = 9$ and $c = 40$, the probability $p = 0,019\ 5$, in the two-tailed test, of concluding that there is a difference between the test and reference samples when in fact there is no difference and the probability is equal to $p = 0,039$.

The test sample is therefore significantly different from the reference sample at the threshold of 5 %. Although the difference is significant, it is possible that it is not very large. However, in the example, the intensity values given by some assessors for the test sample are high. Thus, in this case, it can be concluded that the risk linked to this material is not negligible.

The experimenter will recommend the acceptance or rejection of the test material according to the intensity values obtained, the level of significance fixed and his experience.

It is clear that the final decision is more commercial than statistical.

py: Uni of Science & Technology User, University of Science & Tech, Sat Sep 17 03:31:01 BST 2005, Uncontrolled Copy, (c) BSI



Table E.2 — Critical values of W_{+} for Wilcoxon tests ^a

		N														
		3	4	5	6	7	8	9	10	11	12	13	14	15		
7	0,625 0															
8	0,375 0															
9	0,250 0	0,562 5														
10	0,125 0	0,437 5	0,312 5													
11		0,187 5	0,500 0	0,218 8	0,500 0											
12		0,125 0	0,406 3	0,156 3	0,421 9	0,343 8										
13		0,062 5	0,312 5	0,093 8	0,343 8	0,281 3	0,531 3									
14			0,062 5	0,062 5	0,281 3	0,218 8	0,464 8	0,500 0								
15				0,031 3	0,218 8	0,156 3	0,406 3	0,273 4	0,500 0							
16					0,109 4	0,156 3	0,343 8	0,230 5	0,455 1							
17					0,078 1	0,109 4	0,289 1	0,191 4	0,410 2	0,527 3						
18					0,046 9	0,078 1	0,234 4	0,156 3	0,367 2	0,472 7						
19					0,031 3	0,046 9	0,187 5	0,125 0	0,320 3	0,421 9						
20					0,015 6	0,031 3	0,148 4	0,093 8	0,273 4	0,371 1						
21						0,015 6	0,109 4	0,062 5	0,230 5	0,320 3						
22							0,078 1	0,031 3	0,191 4	0,273 4						
23							0,054 7	0,015 6	0,156 3	0,230 5						
24							0,039 1		0,125 0	0,191 4						
25							0,023 4		0,093 8	0,156 3						
26									0,062 5	0,125 0						



Table E.2 (continued)

		<i>N</i>													
3	4	5	6	7	8	9	10	11	12	13	14	15			
				0,015 6	0,125 0	0,326 2									
				0,007 8	0,097 7	0,285 2	0,500 0								
					0,074 2	0,248 0	0,460 9								
					0,054 7	0,212 9	0,422 9								
					0,039 1	0,179 7	0,384 8								
					0,027 3	0,150 4	0,347 7								
					0,019 5	0,125 0	0,312 5	0,517 1							
					0,011 7	0,101 6	0,278 3	0,482 9							
					0,007 8	0,082 0	0,246 1	0,449 2							
					0,003 9	0,064 5	0,215 8	0,415 5							
						0,048 8	0,187 5	0,382 3							
						0,037 1	0,161 1	0,350 1							
						0,027 3	0,137 7	0,318 8	0,515 1						
						0,019 5	0,116 2	0,288 6	0,484 9						
						0,013 7	0,096 7	0,259 8	0,454 8						
						0,009 8	0,080 1	0,232 4	0,425 0						
						0,005 9	0,065 4	0,206 5	0,395 5						
						0,003 9	0,052 7	0,182 6	0,366 7						
						0,002 0	0,042 0	0,160 2	0,338 6						
							0,032 2	0,139 2	0,311 0	0,500 0					
							0,024 4	0,120 1	0,284 7	0,473 0					
							0,018 6	0,103 0	0,259 3	0,446 3					
							0,013 7	0,087 4	0,234 9	0,419 7					

33
34
35
36
37
38
39
40
41
42
43
44
45
46
47
48
49



Table E.2 (continued)

N														
3	4	5	6	7	8	9	10	11	12	13	14	15		
							0,009 8	0,073 7	0,211 9	0,393 4				
							0,006 8	0,061 5	0,190 2	0,367 7				
							0,004 9	0,050 8	0,169 7	0,342 4				
							0,002 9	0,041 5	0,150 6	0,317 7	0,500 0			
							0,002 0	0,033 7	0,133 1	0,293 9	0,475 8			
							0,001 0	0,026 9	0,116 7	0,270 9	0,451 6			
								0,021 0	0,101 8	0,248 7	0,427 6			
								0,016 1	0,088 1	0,227 4	0,403 9			
								0,012 2	0,075 7	0,207 2	0,380 4			
								0,009 3	0,064 7	0,187 9	0,357 4			
								0,006 8	0,054 9	0,169 8	0,334 9	0,511 0		
								0,004 9	0,046 1	0,152 7	0,312 9	0,489 0		
								0,003 4	0,038 6	0,136 7	0,291 5	0,467 0		
								0,002 4	0,032 0	0,121 9	0,270 8	0,445 2		
								0,001 5	0,026 1	0,108 2	0,250 8	0,423 5		
								0,001 0	0,021 2	0,095 5	0,231 6	0,402 0		
								0,000 5	0,017 1	0,083 9	0,213 1	0,380 8		
									0,013 4	0,073 2	0,195 5	0,359 9		
									0,010 5	0,063 6	0,178 8	0,339 4		
									0,008 1	0,054 9	0,162 9	0,319 3		
									0,006 1	0,047 1	0,147 9	0,299 7		
									0,004 6	0,040 2	0,133 8	0,280 7		

54
55
56
57
58
59
60
61
62
63
64
65
66
67
68
69
70
71



Table E.2 (continued)

		<i>N</i>														
		3	4	5	6	7	8	9	10	11	12	13	14	15		
78											0,003 4	0,034 1	0,120 6	0,262 2		
79											0,002 4	0,028 7	0,108 3	0,244 4		
80											0,001 7	0,023 9	0,096 9	0,227 1		
81											0,001 2	0,019 9	0,086 3	0,210 6		
82											0,000 7	0,016 4	0,076 5	0,194 7		
83											0,000 5	0,013 3	0,067 6	0,179 6		
84											0,000 2	0,010 7	0,059 4	0,165 1		
85											0,008 5	0,008 5	0,052 0	0,151 4		
86											0,006 7	0,006 7	0,045 3	0,138 4		
87											0,005 2	0,005 2	0,039 2	0,126 2		
88											0,004 0	0,004 0	0,033 8	0,114 7		
89											0,003 1	0,003 1	0,029 0	0,103 9		
90											0,002 3	0,002 3	0,024 7	0,093 8		
91											0,001 7	0,001 7	0,020 9	0,084 4		
92											0,001 2	0,001 2	0,017 6	0,075 7		
93											0,000 9	0,000 9	0,014 8	0,067 7		
											0,000 6	0,000 6	0,012 3	0,060 3		
											0,000 4	0,000 4	0,010 1	0,053 5		
											0,000 2	0,000 2	0,008 3	0,047 3		
											0,000 1	0,000 1	0,006 7	0,041 6		
													0,005 4	0,036 5		
													0,004 3	0,031 9		



www.SinoFood.com.cn

Table E.2 (continued)

		<i>N</i>													
		3	4	5	6	7	8	9	10	11	12	13	14	15	
99													0,003 4	0,027 7	
100													0,002 6	0,024 0	
101													0,002 0	0,020 6	
102													0,001 5	0,017 7	
103													0,001 2	0,015 1	
104													0,000 9	0,012 8	
105													0,000 6	0,010 8	
106													0,000 4	0,009 0	
107													0,000 3	0,007 5	
108													0,000 2	0,006 2	
109													0,000 1	0,005 1	
110													0,000 1	0,004 2	
111													0,003 4	0,003 4	
112													0,002 7	0,002 7	
113													0,002 1	0,002 1	
114													0,001 7	0,001 7	
115													0,001 3	0,001 3	
116													0,001 0	0,001 0	
117													0,000 8	0,000 8	
118													0,000 6	0,000 6	
119													0,000 4	0,000 4	
120													0,000 3	0,000 3	
													0,000 2	0,000 2	
													0,000 2	0,000 2	
													0,000 1	0,000 1	
													0,000 1	0,000 1	
													0,000 0	0,000 0	

^a Taken from reference [13]. (Reproduced with the authorization of McGraw Hill, Inc. Copyright given on 1995-07-24.)



Bibliography

- [1] ISO 3972, *Sensory analysis — Methodology — Method of investigating sensitivity of taste*
- [2] ISO 4121, *Sensory analysis — Guidelines for the use of quantitative response scales*
- [3] ISO 5496, *Sensory analysis — Methodology — Initiation and training of assessors in the detection and recognition of odours*
- [4] ISO 6658, *Sensory analysis — Methodology — General guidance*
- [5] ISO 21067, *Packaging — Vocabulary*
- [6] BS 3755, *Methods of test for the assessment of odour from packaging materials used for foodstuffs*
- [7] DIN 10955, *Sensory analysis; testing of container materials and containers of food products*
- [8] EN 1186-1, *Materials and articles in contact with foodstuffs — Plastics — Part 1: Guide to the selection of conditions and test methods for overall migration*
- [9] SCHLICH, P. Risks tables for discrimination tests. *Food Quality and Preference*, **4** (3), 1993, pp. 141-151
- [10] MACFIE, H.J., BRATCHELL, N., GREENHOFF K. and VALLIS, L.V. *Journal of Sensory Studies*, **4** (2), 1989, pp. 129-148
- [11] DGCCRF. Avis du CSHPF relatif aux matériaux au contact des denrées alimentaires — BOCCRF n° 8 du 24.05.96, *Section de l'alimentation et de la nutrition*, Novembre 1995
- [12] SAXBY M.J. (ed.) *Food Taints and Off Flavours*. Blackie Press, 1993, Chapter 7 (ISBN 0751400963)
- [13] SIEGEL, S. and CASTELLAN N.J. Jr. *Nonparametric statistics for the behavioral sciences*. McGraw Hill, 1998 (ISBN 0071003266)
- [14] ROBINSON, L. Méthode d'analyse Feuille 12F/1998, *Transfer of packaging odours to cocoa and chocolate products*. OICC (Office International du Cacao et du Chocolat)
- [15] KATAN L.L. *Migration from food contact migration*. Blackie Press, 1996 (ISBN 0751402370)
- [16] ENV 13130-1, *Materials and articles in contact foodstuffs — Plastics substances subject to limitation — Part 1: Guide to the tests methods for the specific migration of substances from plastic into food and food simulants and the determination of substances in plastics and the selection of conditions of exposure to food simulants*
- [17] European Directive 82/711/CEE, *Basic rules necessary for testing migration of the constituents of plastics materials and articles intended to come into contact with foodstuffs* (Amended by European Directive 93/8/CEE and European Directive 97/48/CEE)

www.sinofood.com.cn



BSI — British Standards Institution

BSI is the independent national body responsible for preparing British Standards. It presents the UK view on standards in Europe and at the international level. It is incorporated by Royal Charter.

Revisions

British Standards are updated by amendment or revision. Users of British Standards should make sure that they possess the latest amendments or editions.

It is the constant aim of BSI to improve the quality of our products and services. We would be grateful if anyone finding an inaccuracy or ambiguity while using this British Standard would inform the Secretary of the technical committee responsible, the identity of which can be found on the inside front cover. Tel: +44 (0)20 8996 9000. Fax: +44 (0)20 8996 7400.

BSI offers members an individual updating service called PLUS which ensures that subscribers automatically receive the latest editions of standards.

Buying standards

Orders for all BSI, international and foreign standards publications should be addressed to Customer Services. Tel: +44 (0)20 8996 9001. Fax: +44 (0)20 8996 7001. Email: orders@bsi-global.com. Standards are also available from the BSI website at <http://www.bsi-global.com>.

In response to orders for international standards, it is BSI policy to supply the BSI implementation of those that have been published as British Standards, unless otherwise requested.

Information on standards

BSI provides a wide range of information on national, European and international standards through its Library and its Technical Help to Exporters Service. Various BSI electronic information services are also available which give details on all its products and services. Contact the Information Centre. Tel: +44 (0)20 8996 7111. Fax: +44 (0)20 8996 7048. Email: info@bsi-global.com.

Subscribing members of BSI are kept up to date with standards developments and receive substantial discounts on the purchase price of standards. For details of these and other benefits contact Membership Administration. Tel: +44 (0)20 8996 7002. Fax: +44 (0)20 8996 7001. Email: membership@bsi-global.com.

Information regarding online access to British Standards via British Standards Online can be found at <http://www.bsi-global.com/bsonline>.

Further information about BSI is available on the BSI website at <http://www.bsi-global.com>.

Copyright

Copyright subsists in all BSI publications. BSI also holds the copyright, in the UK, of the publications of the international standardization bodies. Except as permitted under the Copyright, Designs and Patents Act 1988 no extract may be reproduced, stored in a retrieval system or transmitted in any form or by any means – electronic, photocopying, recording or otherwise – without prior written permission from BSI.

This does not preclude the free use, in the course of implementing the standard, of necessary details such as symbols, and size, type or grade designations. If these details are to be used for any other purpose than implementation then the prior written permission of BSI must be obtained.

Further information and advice can be obtained from the Copyright & Licensing Manager. Tel: +44 (0)20 8996 7070. Fax: +44 (0)20 8996 7553. Email: copyright@bsi-global.com.

This document is now
PUBLIC