



BSI Standards Publication

**Thermoplastics piping systems
for non-pressure underground
drainage and sewerage —
Thermoplastics shafts or risers
for inspection chambers and
manholes — Determination of
ring stiffness**

National foreword

This British Standard is the UK implementation of ISO 13268:2010.

The UK participation in its preparation was entrusted to Technical Committee PRI/88/1, Plastics piping for non-pressure applications.

A list of organizations represented on this committee can be obtained on request to its secretary.

This publication does not purport to include all the necessary provisions of a contract. Users are responsible for its correct application.

© BSI 2010

ISBN 978 0 580 66719 0

ICS 23.040.20; 23.040.45; 91.140.80; 93.030

Compliance with a British Standard cannot confer immunity from legal obligations.

This British Standard was published under the authority of the Standards Policy and Strategy Committee on 31 July 2010

Amendments issued since publication

Date	Text affected
------	---------------

INTERNATIONAL STANDARD

ISO
13268

First edition
2010-06-15

Thermoplastics piping systems for non- pressure underground drainage and sewerage — Thermoplastics shafts or risers for inspection chambers and manholes — Determination of ring stiffness

*Systèmes de canalisations thermoplastiques pour branchements et
collecteurs d'assainissement enterrés sans pression — Éléments de
réhausse thermoplastiques pour chambres d'inspection et de
branchement ou regards — Détermination de la rigidité annulaire*



Reference number
ISO 13268:2010(E)

© ISO 2010

PDF disclaimer

This PDF file may contain embedded typefaces. In accordance with Adobe's licensing policy, this file may be printed or viewed but shall not be edited unless the typefaces which are embedded are licensed to and installed on the computer performing the editing. In downloading this file, parties accept therein the responsibility of not infringing Adobe's licensing policy. The ISO Central Secretariat accepts no liability in this area.

Adobe is a trademark of Adobe Systems Incorporated.

Details of the software products used to create this PDF file can be found in the General Info relative to the file; the PDF-creation parameters were optimized for printing. Every care has been taken to ensure that the file is suitable for use by ISO member bodies. In the unlikely event that a problem relating to it is found, please inform the Central Secretariat at the address given below.



COPYRIGHT PROTECTED DOCUMENT

© ISO 2010

All rights reserved. Unless otherwise specified, no part of this publication may be reproduced or utilized in any form or by any means, electronic or mechanical, including photocopying and microfilm, without permission in writing from either ISO at the address below or ISO's member body in the country of the requester.

ISO copyright office
Case postale 56 • CH-1211 Geneva 20
Tel. + 41 22 749 01 11
Fax + 41 22 749 09 47
E-mail copyright@iso.org
Web www.iso.org

Published in Switzerland

Foreword

ISO (the International Organization for Standardization) is a worldwide federation of national standards bodies (ISO member bodies). The work of preparing International Standards is normally carried out through ISO technical committees. Each member body interested in a subject for which a technical committee has been established has the right to be represented on that committee. International organizations, governmental and non-governmental, in liaison with ISO, also take part in the work. ISO collaborates closely with the International Electrotechnical Commission (IEC) on all matters of electrotechnical standardization.

International Standards are drafted in accordance with the rules given in the ISO/IEC Directives, Part 2.

The main task of technical committees is to prepare International Standards. Draft International Standards adopted by the technical committees are circulated to the member bodies for voting. Publication as an International Standard requires approval by at least 75 % of the member bodies casting a vote.

Attention is drawn to the possibility that some of the elements of this document may be the subject of patent rights. ISO shall not be held responsible for identifying any or all such patent rights.

ISO 13268 was prepared by Technical Committee ISO/TC 138, *Plastics pipes, fittings and valves for the transport of fluids*, Subcommittee SC 1, *Plastics pipes and fittings for soil, waste and drainage (including land drainage)*.

Thermoplastics piping systems for non-pressure underground drainage and sewerage — Thermoplastics shafts or risers for inspection chambers and manholes — Determination of ring stiffness

1 Scope

This International Standard specifies a test method for assessing the initial (short-term) tangential ring stiffness of riser shafts for thermoplastics inspection chambers or manholes.

2 Normative references

The following referenced documents are indispensable for the application of this document. For dated references, only the edition cited applies. For undated references, the latest edition of the referenced document (including any amendments) applies.

ISO 48, *Rubber, vulcanized or thermoplastic — Determination of hardness (hardness between 10 IRHD and 100 IRHD)*

ISO 9969, *Thermoplastics pipes — Determination of ring stiffness*

3 Terms and definitions

For the purposes of this document, the following terms and definitions apply.

3.1

inspection chamber

drainage and sewerage fitting used for the connection of drainage or sewerage installations and for changing the direction of drainage or sewerage runs

NOTE An inspection chamber terminates at ground level, permitting the introduction of cleaning, inspection and test equipment and the removal of debris, but it does not provide access for personnel. The riser shaft connected to these fittings has a minimum outside diameter of 200 mm and a maximum inside diameter of less than 800 mm.

3.2

manhole

drainage and sewerage fitting used for the connection of drainage or sewerage installations and for changing the direction of drainage or sewerage runs

NOTE A manhole terminates at ground level, permitting the introduction of cleaning, inspection and test equipment and the removal of debris, and also providing access for personnel. The minimum inside diameter of a manhole riser shaft is 800 mm.

3.3

structured-wall ancillary fitting

fitting with an optimized structural design with regard to material usage, but which still achieves the relevant performance requirements

NOTE These fittings can be circular or rectangular in design.

**3.4
 regular cross section shaft**

riser shaft either fabricated from plain pipe or from structured wall pipe or fittings with a regular symmetrical design on their external surface

NOTE These products can be manufactured by extrusion, injection moulding, blow moulding or rotational moulding.

**3.5
 irregular cross section shaft**

riser shaft with an irregular asymmetrical design on its external surface, such as those with additional reinforcing rings or structures intended to strengthen the riser in specific areas

NOTE These products can be manufactured by extrusion, injection moulding, blow moulding or rotational moulding.

4 Principle

4.1 General

The ring stiffness of a shaft shall be determined using the ISO 9969 test method when the shaft has a circular and regular cross-section.

Where a shaft has a square or rectangular cross-section, or if the shape is irregular, the ISO 9969 test shall be modified as described in this International Standard to determine the ring stiffness (see Table 1).

Table 1 — Relevant International Standards for determination of ring stiffness

External shaft design	Type of cross-section	Relevant International Standard for determination of ring stiffness
Plain surface	Regular cross-section and circular	ISO 9969
	Irregular cross-section, circular, square or rectangular	This International Standard
Structured wall surface	Regular cross-section and circular	ISO 9969
	Irregular cross-section, circular, square or rectangular	This International Standard

4.2 Principle for shafts with circular and regular cross-section

The ring stiffness shall be determined by measuring the force and the deflection while deflecting the shaft at a constant rate.

A length of shaft supported horizontally shall be compressed vertically between two parallel flat plates moved at a constant speed, which is dependent upon the diameter of the shaft.

A plot of force versus deflection shall be generated. The ring stiffness shall be calculated as a function of the force necessary to produce a deflection of $0,03d_i$ diametrically across the shaft.

4.3 Principle for shafts with circular and irregular cross-section or square or rectangular

The ring stiffness shall be determined by measuring the force and deflection whilst deflecting the shaft at a constant rate or constant load, until sufficient force is applied to obtain a resulting deflection in the range of 2 % to 6 %.

A riser shaft or segment of shaft shall be placed symmetrically between two rigid parallel plates or beams or, alternatively, between one rigid beam and a V-shaped support. A compressive force shall be applied to the shaft or segment using a bearer shaped to the external surface of the test piece.

The ring stiffness shall be calculated as a function of the force required to produce the deflection.

5 Apparatus

5.1 Shaft with circular and regular cross-section

The apparatus shall conform to that described in ISO 9969.

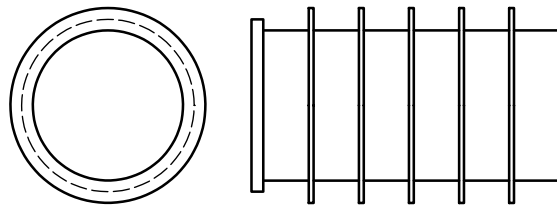

Figure 1 — Shaft with circular and regular cross-section

5.2 Shaft with circular and irregular cross-section or square or rectangular

NOTE Examples for representative test pieces are shown in Figures 2 and 3.

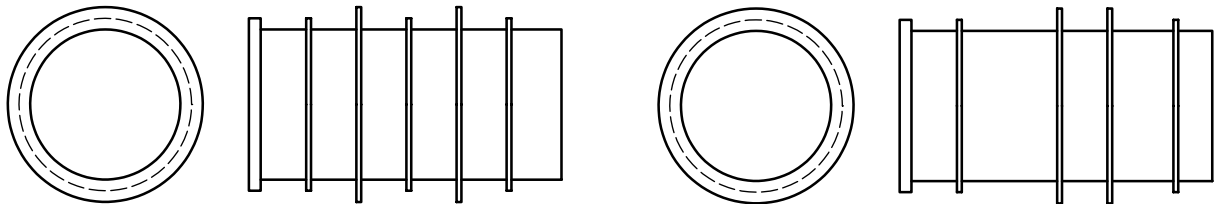

Figure 2 — Shafts with circular and irregular cross-section

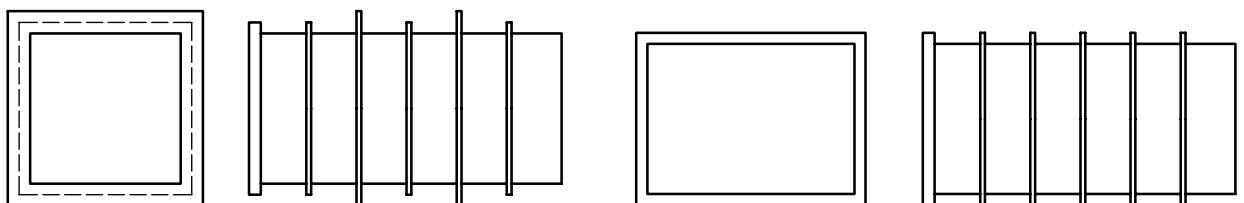

Figure 3 — Square and rectangular shaft

5.2.1 Loading frame, with two rigid parallel plates or beams, between which a compressive force, F , can be applied to the test piece such that the force and the resulting deflection of the test piece in the direction of the force can be measured to an accuracy of $\pm 1\%$.

Where a V-shaped support is used, the included angle shall be 170° or more.

For shafts with square or rectangular cross-sections, the bearers shall have a width, W , not greater than 25 mm.

For circular shafts with irregular cross-section, the maximum width of bearers shall be for:

- $DN/ID \leq 400$: 50 mm;
- $400 < DN/ID \leq 1\,200$: $0,12 \times [DN/ID]$, expressed in millimetres;
- $DN/ID > 1\,200$: 150 mm.

NOTE The above values have been taken from EN 476:1997, 9.2.1^[1].

Where the outside of an irregular shaft has a change in cross-section incorporated within the test piece, the bearers shall be shaped to accommodate this (see Figure 4). Where square or rectangular shafts have a regular rib configuration, this shall not be considered not to be a change in cross-section, and the load, F , imposed shall be applied just to the crests of the ribs.

The centre of loading shall be so arranged that the vertical deflection of the two ends of the test piece differs by not more than 0,5 % of the nominal size of the shaft.

Where the surface of the outside of the shaft does not provide a smooth bearing contact, the bearers shall be surfaced with a strip, not less than 3 mm thick, of elastomeric material of (50 ± 5) IRHD hardness in accordance with ISO 48.

The length of each bearer shall be not less than the length of the test piece.

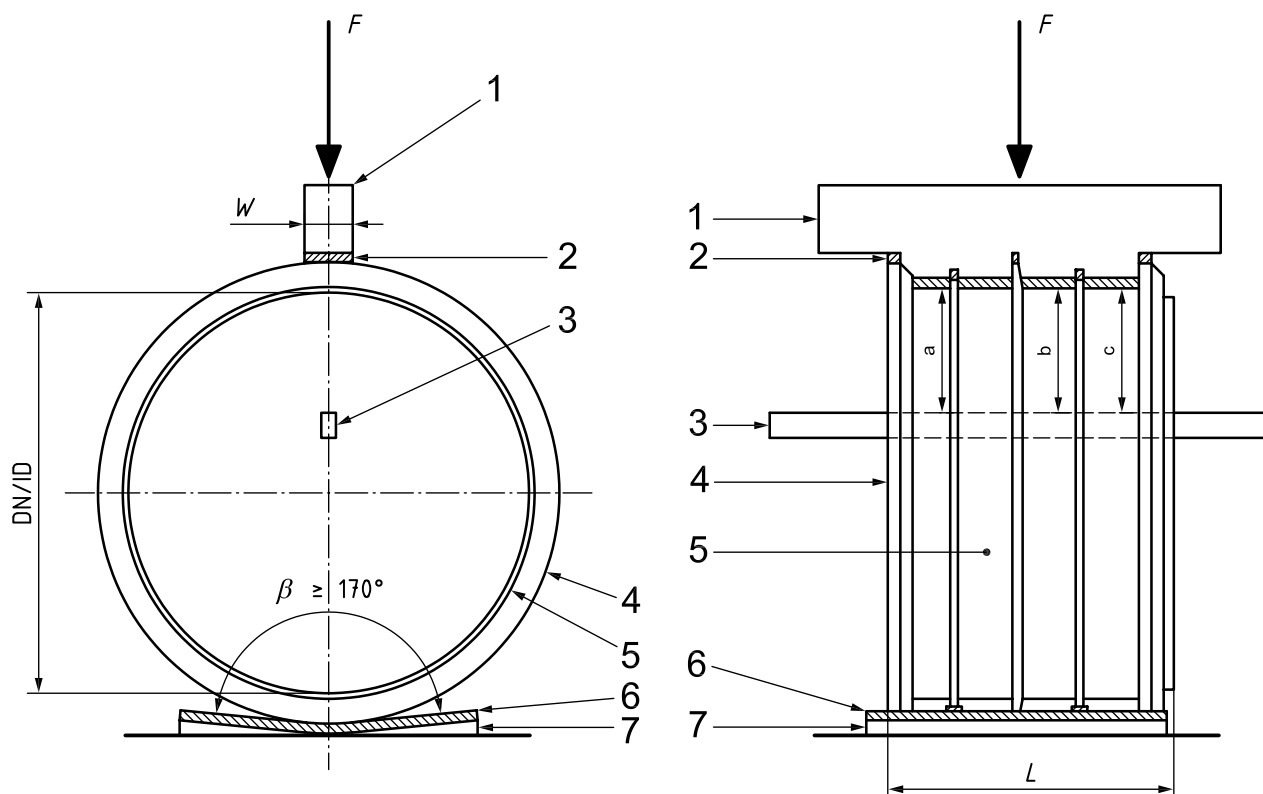

Key

- 1 bearer, accommodated to shape of test piece
- 2 elastomeric strips
- 3 reference beam for measuring
- 4 joint element, assembled, comprising standard sealing system of the manufacturer
- 5 test piece
- 6 elastomeric material
- 7 support

- F load, applied to upper bearer
- L length of test piece
- W width of bearer
- a Measuring point 1.
- b Measuring point 2.
- c Measuring point 3.

Figure 4 — Loading arrangement

5.2.2 Measuring devices, capable of determining the length to an accuracy of $\pm 0,5$ mm and the force and deflection along the length of the test piece to an accuracy of ± 1 % in the direction of the applied force.

6 Test pieces

6.1 Number of test pieces

Three test pieces shall be taken, each consisting of a riser or an appropriate length of riser segment incorporating a joint element, if required.

6.2 Age of test pieces

Test pieces shall be (21 ± 2) days old and conditioned, in air, at ambient temperature for at least 24 h prior to testing.

6.3 Specification of test pieces

6.3.1 Shafts with circular and regular cross-section

When the shaft has a circular and regular cross-section, the test piece shall be in accordance with ISO 9969 and have a minimum length of 300 mm. In the case of a one-piece chamber or manhole, the shaft shall be cut off at a minimum of 300 mm from the top of the main channel. It shall be cut smoothly and perpendicular to the main axis.

6.3.2 Shafts with a square, rectangular or irregular cross-section

When the chamber or manhole consists of a chamber base and a separate shaft, the whole shaft with an additional joint element shall be used as the test piece. The additional joint element shall be connected with the shaft by using the standard sealing or welding system of the manufacturer (see Figure 5).

In the case of a one-piece chamber or manhole, the test piece shall be cut off at a minimum of 300 mm from the top of the main channel. It shall be cut smoothly and perpendicular to the main axis of the chamber or manhole. The length of the piece shall be chosen to obtain maximum symmetry, but shall be not less than 300 mm and not exceed 1 000 mm.

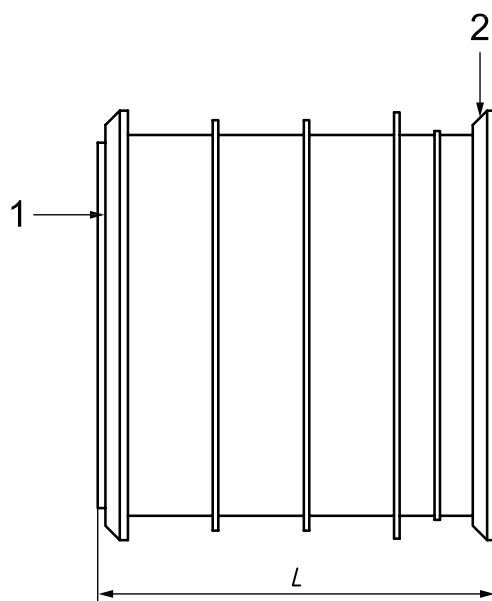

Key

- 1 joint element
- 2 joint element connected with the standard sealing system of the manufacturer

Figure 5 — Shaft with an irregular cross-section connected with a joint element

7 Procedure

7.1 Test temperature

The test shall be conducted at a temperature of $(23 \pm 2) ^\circ\text{C}$.

7.2 Shafts with circular and regular cross-section

The test shall be carried out in accordance with ISO 9969.

7.3 Shafts with a square, rectangular or irregular cross-section

7.3.1 Procedure

7.3.1.1 Assemble the test piece symmetrically in the test apparatus. The line of loading and support for non-circular sections shall be at the centre of the longest side.

7.3.1.2 Determine the datum for deflection at zero load without applied force at three points of measurement. One of the measuring points shall be in the middle of the test piece, the other two points being near either end.

7.3.1.3 Apply sufficient force to obtain a deflection of 2 % to 6 % of the shaft. The rate of loading shall be uniform such that the force required to generate the deflection is applied within a period of 3 min to 6 min. The centre of loading shall be so arranged that the vertical deflection of the test piece at the three points of measurement differs by not more than 0,5 % of the nominal dimension of the shaft (between the loading plates) along the line of deformation. If the test piece incorporates a change in cross-section on the inside of the shaft, the deflection shall be determined on the short side of the smallest cross-section for a square or rectangular section.

NOTE This is comparable to $0,03d_i$ from ISO 9969.

7.3.1.4 Repeat the test on another two test pieces, ensuring that they are deflected in different planes each 120° apart from the first test piece, if circular or 90° , if square or rectangular.

8 Calculation

8.1 Shafts with a circular and regular cross-section

The ring stiffness shall be calculated as described in ISO 9969.

8.2 Shafts with square, rectangular or irregular cross-section

Calculate the ring stiffness, S , in Pascals, from Equation (1):

$$S = \frac{0,0186}{\bar{L}} \times \frac{\bar{F}}{\bar{Y}} \times S_f \quad (1)$$

where

\bar{F} is the arithmetic mean of the three forces, in newtons;

\bar{L} is the arithmetic mean of the three specimen lengths, in metres;

\bar{Y} is the arithmetic mean of the three deflections, in metres;

S_f is the shape factor, the value of which depends upon the shape of the test piece section as follows:

- for circular sections: $S_f = 1,0$;
- for square or rectangular sections:

$$S_f = 0,56 \sqrt{\frac{L^4 + (4L^3 \times l)}{L^3 (L + l)}} \quad (2)$$

where

L is the length, in metres, of the long side;

l is the length, in metres, of the short side.

If the shaft incorporates a change in cross-section on the inside of the shaft, the value of S_f used shall be the mean value of that for the maximum dimension and that for the minimum dimension.

9 Test report

The test report shall include the following information:

- a) reference to this International Standard, i.e. ISO 13268:2010, and the referring standard;
- b) all details necessary for complete identification of the shaft tested, including:
 - 1) name and address of the manufacturer;
 - 2) type of shaft (including the material and method of sealing);
 - 3) dimensions;
 - 4) date of production;
 - 5) age of the shaft at the date of the test;
 - 6) length of the three test pieces;
- c) test temperature;
- d) time taken to apply the load needed to generate the deflection for each test piece;
- e) calculated value of the ring stiffness, S , to three decimal places;
- f) any factor that might have affected the results, such as any incident or any operating detail not specified in this International Standard;
- g) date of the test.

Bibliography

- [1] EN 476:1997, *General requirements for components used in discharge pipes, drains and sewers for gravity systems*

ICS 23.040.20; 23.040.45; 91.140.80; 93.030

Price based on 9 pages

British Standards Institution (BSI)

BSI is the national body responsible for preparing British Standards and other standards-related publications, information and services.

BSI is incorporated by Royal Charter. British Standards and other standardization products are published by BSI Standards Limited.

About us

We bring together business, industry, government, consumers, innovators and others to shape their combined experience and expertise into standards-based solutions.

The knowledge embodied in our standards has been carefully assembled in a dependable format and refined through our open consultation process. Organizations of all sizes and across all sectors choose standards to help them achieve their goals.

Information on standards

We can provide you with the knowledge that your organization needs to succeed. Find out more about British Standards by visiting our website at bsigroup.com/standards or contacting our Customer Services team or Knowledge Centre.

Buying standards

You can buy and download PDF versions of BSI publications, including British and adopted European and international standards, through our website at bsigroup.com/shop, where hard copies can also be purchased.

If you need international and foreign standards from other Standards Development Organizations, hard copies can be ordered from our Customer Services team.

Subscriptions

Our range of subscription services are designed to make using standards easier for you. For further information on our subscription products go to bsigroup.com/subscriptions.

With **British Standards Online (BSOL)** you'll have instant access to over 55,000 British and adopted European and international standards from your desktop. It's available 24/7 and is refreshed daily so you'll always be up to date.

You can keep in touch with standards developments and receive substantial discounts on the purchase price of standards, both in single copy and subscription format, by becoming a **BSI Subscribing Member**.

PLUS is an updating service exclusive to BSI Subscribing Members. You will automatically receive the latest hard copy of your standards when they're revised or replaced.

To find out more about becoming a BSI Subscribing Member and the benefits of membership, please visit bsigroup.com/shop.

With a **Multi-User Network Licence (MUNL)** you are able to host standards publications on your intranet. Licences can cover as few or as many users as you wish. With updates supplied as soon as they're available, you can be sure your documentation is current. For further information, email bsmusales@bsigroup.com.

BSI Group Headquarters

389 Chiswick High Road London W4 4AL UK

Revisions

Our British Standards and other publications are updated by amendment or revision.

We continually improve the quality of our products and services to benefit your business. If you find an inaccuracy or ambiguity within a British Standard or other BSI publication please inform the Knowledge Centre.

Copyright

All the data, software and documentation set out in all British Standards and other BSI publications are the property of and copyrighted by BSI, or some person or entity that owns copyright in the information used (such as the international standardization bodies) and has formally licensed such information to BSI for commercial publication and use. Except as permitted under the Copyright, Designs and Patents Act 1988 no extract may be reproduced, stored in a retrieval system or transmitted in any form or by any means – electronic, photocopying, recording or otherwise – without prior written permission from BSI. Details and advice can be obtained from the Copyright & Licensing Department.

Useful Contacts:

Customer Services

Tel: +44 845 086 9001

Email (orders): orders@bsigroup.com

Email (enquiries): cservices@bsigroup.com

Subscriptions

Tel: +44 845 086 9001

Email: subscriptions@bsigroup.com

Knowledge Centre

Tel: +44 20 8996 7004

Email: knowledgecentre@bsigroup.com

Copyright & Licensing

Tel: +44 20 8996 7070

Email: copyright@bsigroup.com

bsi.

...making excellence a habit.™