

BS ISO 13264:2010



BSI Standards Publication

**Thermoplastics piping systems
for non-pressure underground
drainage and sewerage —
Thermoplastics fittings —
Test method for mechanical
strength or flexibility of
fabricated fittings**

bsi.

...making excellence a habit.™

National foreword

This British Standard is the UK implementation of ISO 13264:2010.

The UK participation in its preparation was entrusted to Technical Committee PRI/88/1, Plastics piping for non-pressure applications.

A list of organizations represented on this committee can be obtained on request to its secretary.

This publication does not purport to include all the necessary provisions of a contract. Users are responsible for its correct application.

© BSI 2010

ISBN 978 0 580 66714 5

ICS 23.040.20; 23.040.45; 91.140.80; 93.030

Compliance with a British Standard cannot confer immunity from legal obligations.

This British Standard was published under the authority of the Standards Policy and Strategy Committee on 31 July 2010

Amendments issued since publication

Date	Text affected
------	---------------

INTERNATIONAL STANDARD

BS ISO 13264:2010

ISO
13264

First edition
2010-06-01

Thermoplastics piping systems for non- pressure underground drainage and sewerage — Thermoplastics fittings — Test method for mechanical strength or flexibility of fabricated fittings

*Systèmes de canalisations thermoplastiques pour branchements et
collecteurs d'assainissement enterrés sans pression — Raccords
thermoplastiques — Méthode d'essai de la résistance mécanique ou de
la flexibilité des raccords façonnés*



Reference number
ISO 13264:2010(E)

© ISO 2010

PDF disclaimer

This PDF file may contain embedded typefaces. In accordance with Adobe's licensing policy, this file may be printed or viewed but shall not be edited unless the typefaces which are embedded are licensed to and installed on the computer performing the editing. In downloading this file, parties accept therein the responsibility of not infringing Adobe's licensing policy. The ISO Central Secretariat accepts no liability in this area.

Adobe is a trademark of Adobe Systems Incorporated.

Details of the software products used to create this PDF file can be found in the General Info relative to the file; the PDF-creation parameters were optimized for printing. Every care has been taken to ensure that the file is suitable for use by ISO member bodies. In the unlikely event that a problem relating to it is found, please inform the Central Secretariat at the address given below.



COPYRIGHT PROTECTED DOCUMENT

© ISO 2010

All rights reserved. Unless otherwise specified, no part of this publication may be reproduced or utilized in any form or by any means, electronic or mechanical, including photocopying and microfilm, without permission in writing from either ISO at the address below or ISO's member body in the country of the requester.

ISO copyright office
Case postale 56 • CH-1211 Geneva 20
Tel. + 41 22 749 01 11
Fax + 41 22 749 09 47
E-mail copyright@iso.org
Web www.iso.org

Published in Switzerland

Foreword

ISO (the International Organization for Standardization) is a worldwide federation of national standards bodies (ISO member bodies). The work of preparing International Standards is normally carried out through ISO technical committees. Each member body interested in a subject for which a technical committee has been established has the right to be represented on that committee. International organizations, governmental and non-governmental, in liaison with ISO, also take part in the work. ISO collaborates closely with the International Electrotechnical Commission (IEC) on all matters of electrotechnical standardization.

International Standards are drafted in accordance with the rules given in the ISO/IEC Directives, Part 2.

The main task of technical committees is to prepare International Standards. Draft International Standards adopted by the technical committees are circulated to the member bodies for voting. Publication as an International Standard requires approval by at least 75 % of the member bodies casting a vote.

Attention is drawn to the possibility that some of the elements of this document may be the subject of patent rights. ISO shall not be held responsible for identifying any or all such patent rights.

ISO 13264 was prepared by Technical Committee ISO/TC 138, *Plastics pipes, fittings and valves for the transport of fluids*, Subcommittee SC 1, *Plastics pipes and fittings for soil, waste and drainage (including land drainage)*.

Thermoplastics piping systems for non-pressure underground drainage and sewerage — Thermoplastics fittings — Test method for mechanical strength or flexibility of fabricated fittings

1 Scope

This International Standard specifies a method for testing the mechanical strength or flexibility of a fabricated thermoplastic fitting intended to be used in non-pressure underground applications.

2 Principle

An assembly of a fabricated fitting and the relevant number of adjacent pipes and anchorages (see Figures 1 and 2) is subjected to a moment at the critical point. The critical point is where structural damage is most likely to start when increasing the moment.

Either a specified moment, M , or a specified displacement, A , becomes the determining factor, whichever is reached first.

It is assumed that the following test parameters are set by the referring standard:

- a) the sampling procedure and the number of test pieces (see 4.2);
- b) the conditioning temperature, if other than $(23 \pm 5) ^\circ\text{C}$ (see Clause 5);
- c) the conditioning time, if other than 21 days (see Clause 5);
- d) if appropriate, the moment ($M = F \times L$) or displacement to be applied (see Clause 6).

3 Apparatus

3.1 Anchorage(s), capable of maintaining the body of the fabricated fitting rigid during the test. The anchorages shall not deform the fitting.

3.2 Equipment for applying a force, that results in a moment in the critical point (see Clause 6).

The direction of the force can be clockwise or anticlockwise provided tensile stresses are applied to the critical point.

3.3 Equipment for determining the length, L , of the arm to the critical point (see Figures 1 and 2).

When the displacement, A , is the determining factor, the arm, L , as shown in Figures 1 and 2, shall be $(1\ 200 \pm 10)$ mm.

3.4 Force and displacement measurement instruments, capable of determining the force applied and the displacement of the end of the arm to which the force is applied, as applicable (see Clause 4 and Table 1).

If a socket is designed to take up an angular deflection, β , the total displacement shall be the sum of the displacement given by the design angle, β , as declared by the manufacturer, plus the specified displacement. In this case, however, a mechanical arrangement, where the arm is fixed to the socket, is preferred.

3.5 Additional means, to ensure the tightness of the joint (see Clause 4), if necessary.

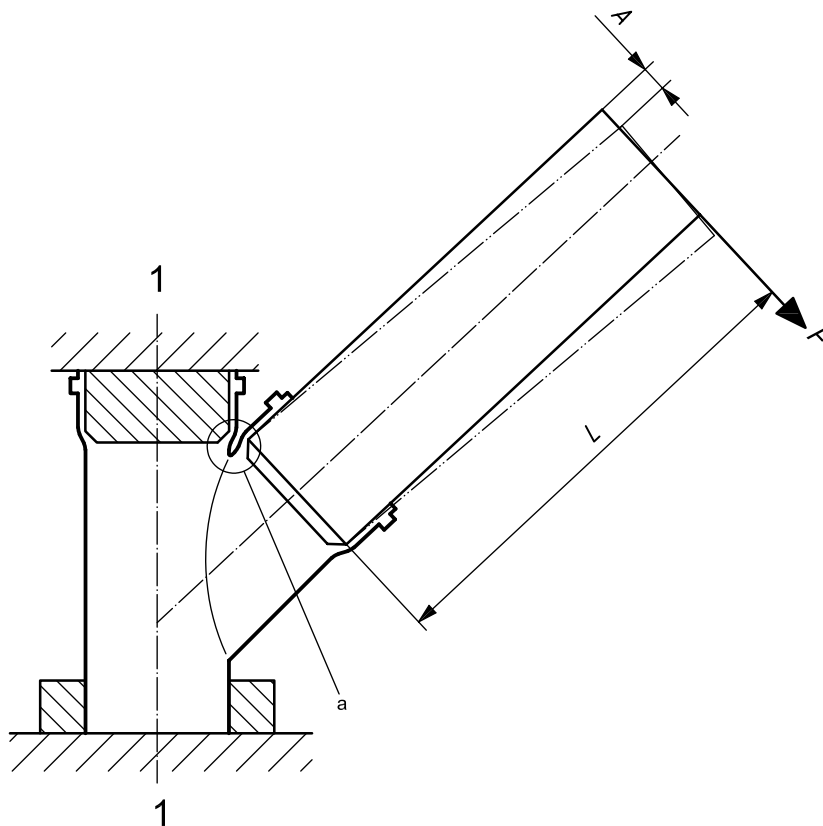

Key

- 1 fixing
- A displacement
- F force applied
- L arm
- a Example of critical point (see Clause 2).

Figure 1 — Typical test assembly for a branch with a socket

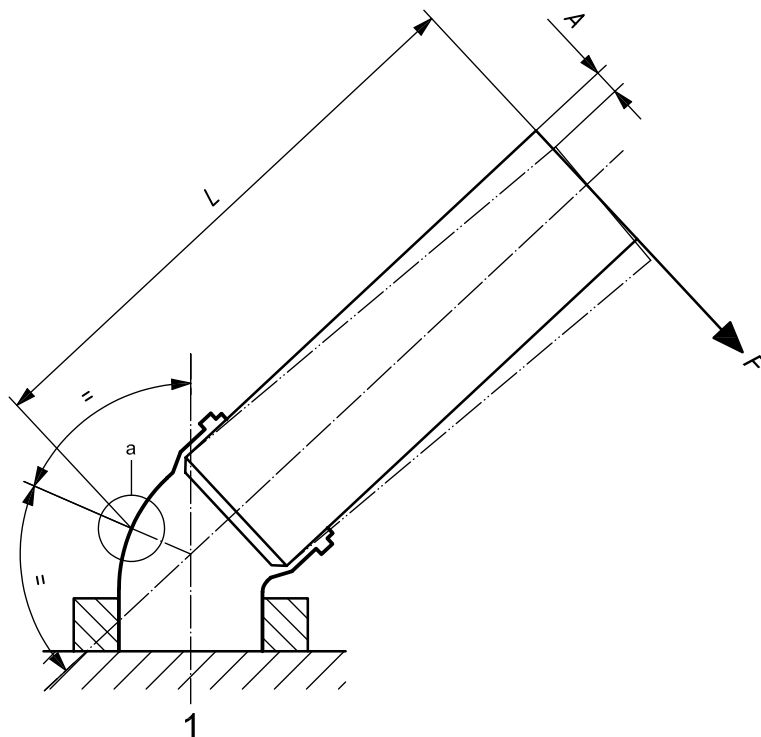

Key

- 1 fixing
- A* displacement
- F* force applied
- L* arm
- a* Example of critical point (see Clause 2).

Figure 2 — Typical test assembly for a bend with a socket

4 Test pieces

4.1 Preparation

The test piece shall comprise an assembly of the fabricated fitting with a pipe of the ring stiffness class for which the fitting is designed and fixings, as appropriate.

In cases where a fitting is designed for both solid-wall and structured-wall pipes, a solid-wall pipe shall be used.

If the limiting factor is the moment, *M*, the pipe may be replaced by a mechanical arrangement that ensures that the required moment is applied.

If the limiting factor is the displacement, *A*, the pipe may be replaced by a mechanical arrangement of longitudinal rigidity not less than that of the specified pipe. In case of dispute, the specified pipe shall be used.

Where a joint between a pipe and a fabricated fitting is made, the manufacturer's instructions shall be followed although additional means may be used to ensure the tightness of the joint during the test.

4.2 Sampling procedure and number of test pieces

The sampling procedure and number of test pieces shall be as specified in the referring standard.

5 Conditioning

Samples shall be stored at a room temperature of (23 ± 5) °C for at least 21 days before testing, unless otherwise specified in the referring standard.

6 Procedure

6.1 Non-mechanical jointed fabricated fittings — Cemented or fused

Carry out the following procedure at (23 ± 5) °C.

Assemble the fitting with the pipe or mechanical arrangement (see 4.1) and fix it as shown in Figure 1 or 2.

If possible, fill the assembly with water or air pressure.

Apply the necessary force in 1 s to 20 s to obtain the specified moment at the critical point or the specified displacement as given in Table 1, unless otherwise specified in the referring standard.

Maintain the force or the displacement applied for 15 min while monitoring for and recording any signs of splitting, cracking, separation and leakage. The inspection may be performed after relaxing the force or displacement and, if necessary, after removing the anchorage, by applying water or air pressure or vacuum.

NOTE The level of air pressure or vacuum is not specified because it is only used to detect leakage.

Record any leakage at the fabricated joint as a failure.

6.2 Mechanical jointed fabricated fittings

Carry out the following procedure at (23 ± 5) °C.

Assemble the fitting with the pipe or mechanical arrangement (see 4.1) and fix it as shown in Figure 1 or 2.

Fill the assembly with water until the level is between 200 mm and 300 mm above the critical point.

Apply the necessary force in 1 s to 20 s to obtain the specified moment at the critical point or the specified displacement as given in Table 1, unless otherwise specified in the referring standard.

Maintain the force or the displacement applied for 15 min while monitoring for and recording any signs of splitting, cracking, separation and leakage.

Record any leakage at the fabricated joint as a failure.

Table 1 — Moment/displacement to be applied

Nominal size DN/OD ^a mm	Minimum moment <i>M</i> kN·m	Minimum displacement <i>L</i> mm
110	0,20	170
125	0,29	170
160	0,61	170
200	1,20	170
250	2,30	170
315	3,10	170
355	3,50	170
400	4,00	170
450	4,50	170
500	5,00	170
630	6,30	170
710	7,10	170
800	8,00	170
900	9,00	170
1 000	10,00	170

^a For fittings of a DN/ID series, conduct the test using the parameters specified for the next larger DN/OD pipe rather than the actual outside diameter of the corresponding pipe.

For DN/ODs up to and including 250 mm, the figures of the minimum moment approximate to Equation (1):

$$M = 0,15 \times [\text{DN}]^3 \times 10^{-6} \text{ kN}\cdot\text{m} \quad (1)$$

For DN/ODs greater than 250 mm, Equation (2) is used:

$$M = 0,010 \times [\text{DN}] \text{ kN}\cdot\text{m} \quad (2)$$

7 Test report

The test report shall include the following information:

- a reference to this International Standard, i.e. ISO 13264:2010, and the referring standard;
- the identity of the product(s) tested, including the stiffness of the pipe used, if applicable;
- the method of jointing, e.g. mechanical, cemented, fused;
- the method used for determining splitting, cracking, separation and leakage;
- the determining factor applicable, i.e. moment or displacement;

- f) a brief description of the test apparatus;
- g) the permitted angular deflection, if any (see 3.4);
- h) the moment or the displacement applied;
- i) details of any signs of splitting, cracking, separation and leakage;
- j) any factor that could have affected the results, such as any incident or any operating detail not specified in this International Standard;
- k) the date of test.

ICS 23.040.20; 23.040.45; 91.140.80; 93.030

Price based on 6 pages

British Standards Institution (BSI)

BSI is the national body responsible for preparing British Standards and other standards-related publications, information and services.

BSI is incorporated by Royal Charter. British Standards and other standardization products are published by BSI Standards Limited.

About us

We bring together business, industry, government, consumers, innovators and others to shape their combined experience and expertise into standards-based solutions.

The knowledge embodied in our standards has been carefully assembled in a dependable format and refined through our open consultation process. Organizations of all sizes and across all sectors choose standards to help them achieve their goals.

Information on standards

We can provide you with the knowledge that your organization needs to succeed. Find out more about British Standards by visiting our website at bsigroup.com/standards or contacting our Customer Services team or Knowledge Centre.

Buying standards

You can buy and download PDF versions of BSI publications, including British and adopted European and international standards, through our website at bsigroup.com/shop, where hard copies can also be purchased.

If you need international and foreign standards from other Standards Development Organizations, hard copies can be ordered from our Customer Services team.

Subscriptions

Our range of subscription services are designed to make using standards easier for you. For further information on our subscription products go to bsigroup.com/subscriptions.

With **British Standards Online (BSOL)** you'll have instant access to over 55,000 British and adopted European and international standards from your desktop. It's available 24/7 and is refreshed daily so you'll always be up to date.

You can keep in touch with standards developments and receive substantial discounts on the purchase price of standards, both in single copy and subscription format, by becoming a **BSI Subscribing Member**.

PLUS is an updating service exclusive to BSI Subscribing Members. You will automatically receive the latest hard copy of your standards when they're revised or replaced.

To find out more about becoming a BSI Subscribing Member and the benefits of membership, please visit bsigroup.com/shop.

With a **Multi-User Network Licence (MUNL)** you are able to host standards publications on your intranet. Licences can cover as few or as many users as you wish. With updates supplied as soon as they're available, you can be sure your documentation is current. For further information, email bsmusales@bsigroup.com.

BSI Group Headquarters

389 Chiswick High Road London W4 4AL UK



Revisions

Our British Standards and other publications are updated by amendment or revision.

We continually improve the quality of our products and services to benefit your business. If you find an inaccuracy or ambiguity within a British Standard or other BSI publication please inform the Knowledge Centre.

Copyright

All the data, software and documentation set out in all British Standards and other BSI publications are the property of and copyrighted by BSI, or some person or entity that owns copyright in the information used (such as the international standardization bodies) and has formally licensed such information to BSI for commercial publication and use. Except as permitted under the Copyright, Designs and Patents Act 1988 no extract may be reproduced, stored in a retrieval system or transmitted in any form or by any means – electronic, photocopying, recording or otherwise – without prior written permission from BSI. Details and advice can be obtained from the Copyright & Licensing Department.

Useful Contacts:

Customer Services

Tel: +44 845 086 9001

Email (orders): orders@bsigroup.com

Email (enquiries): cservices@bsigroup.com

Subscriptions

Tel: +44 845 086 9001

Email: subscriptions@bsigroup.com

Knowledge Centre

Tel: +44 20 8996 7004

Email: knowledgecentre@bsigroup.com

Copyright & Licensing

Tel: +44 20 8996 7070

Email: copyright@bsigroup.com

...making excellence a habit.™