

Test conditions for numerically controlled turning machines and turning centres

Part 6: Accuracy of a finished test piece

ICS 25.040.20

National foreword

This British Standard is the UK implementation of ISO 13041-6:2009. It supersedes BS ISO 13041-6:2005 which is withdrawn.

The UK participation in its preparation was entrusted to Technical Committee MTE/1/2, Machine tools - Accuracy.

A list of organizations represented on this committee can be obtained on request to its secretary.

This publication does not purport to include all the necessary provisions of a contract. Users are responsible for its correct application.

Compliance with a British Standard cannot confer immunity from legal obligations.

This British Standard was published under the authority of the Standards Policy and Strategy Committee on 31 August 2009

© BSI 2009

ISBN 978 0 580 60651 9

Amendments/corrigenda issued since publication

Date	Comments

**Test conditions for numerically controlled
turning machines and turning centres —**

Part 6:
Accuracy of a finished test piece

*Conditions d'essai des tours à commande numérique et des centres de
tournage —*

Partie 6: Exactitude d'une pièce d'essai usinée



PDF disclaimer

This PDF file may contain embedded typefaces. In accordance with Adobe's licensing policy, this file may be printed or viewed but shall not be edited unless the typefaces which are embedded are licensed to and installed on the computer performing the editing. In downloading this file, parties accept therein the responsibility of not infringing Adobe's licensing policy. The ISO Central Secretariat accepts no liability in this area.

Adobe is a trademark of Adobe Systems Incorporated.

Details of the software products used to create this PDF file can be found in the General Info relative to the file; the PDF-creation parameters were optimized for printing. Every care has been taken to ensure that the file is suitable for use by ISO member bodies. In the unlikely event that a problem relating to it is found, please inform the Central Secretariat at the address given below.



COPYRIGHT PROTECTED DOCUMENT

© ISO 2009

All rights reserved. Unless otherwise specified, no part of this publication may be reproduced or utilized in any form or by any means, electronic or mechanical, including photocopying and microfilm, without permission in writing from either ISO at the address below or ISO's member body in the country of the requester.

ISO copyright office
Case postale 56 • CH-1211 Geneva 20
Tel. + 41 22 749 01 11
Fax + 41 22 749 09 47
E-mail copyright@iso.org
Web www.iso.org

Published in Switzerland

Contents

Page

Foreword.....	iv
Introduction	v
1 Scope	1
2 Normative references	1
3 Preliminary remarks	1
3.1 Measuring units	1
3.2 Reference to ISO 230	2
3.3 Test sequence	2
3.4 Tests to be performed	2
3.5 Measuring instruments	2
3.6 Fixing of test pieces	2
3.7 Materials of test pieces, tooling and cutting parameters	2
3.8 Sizes of test pieces.....	2
3.9 Information to be recorded	3
3.10 Machine size categories.....	3
4 Machining tests.....	5
Bibliography	12

Foreword

ISO (the International Organization for Standardization) is a worldwide federation of national standards bodies (ISO member bodies). The work of preparing International Standards is normally carried out through ISO technical committees. Each member body interested in a subject for which a technical committee has been established has the right to be represented on that committee. International organizations, governmental and non-governmental, in liaison with ISO, also take part in the work. ISO collaborates closely with the International Electrotechnical Commission (IEC) on all matters of electrotechnical standardization.

International Standards are drafted in accordance with the rules given in the ISO/IEC Directives, Part 2.

The main task of technical committees is to prepare International Standards. Draft International Standards adopted by the technical committees are circulated to the member bodies for voting. Publication as an International Standard requires approval by at least 75 % of the member bodies casting a vote.

Attention is drawn to the possibility that some of the elements of this document may be the subject of patent rights. ISO shall not be held responsible for identifying any or all such patent rights.

ISO 13041-6 was prepared by Technical Committee ISO/TC 39, *Machine tools*, Subcommittee SC 2, *Test conditions for metal cutting machine tools*.

This second edition cancels and replaces the first edition (ISO 13041-6:2005), which has been technically revised.

ISO 13041 consists of the following parts, under the general title *Test conditions for numerically controlled turning machines and turning centres*:

- *Part 1: Geometric tests for machines with a horizontal workholding spindle*
- *Part 2: Geometric tests for machines with a vertical workholding spindle*
- *Part 3: Geometric tests for machines with inverted vertical workholding spindles*
- *Part 4: Accuracy and repeatability of positioning of linear and rotary axes*
- *Part 5: Accuracy of feeds, speeds and interpolations*
- *Part 6: Accuracy of a finished test piece*
- *Part 7: Evaluation of contouring performance in the coordinate planes*
- *Part 8: Evaluation of thermal distortions*

Introduction

A numerically controlled turning machine is a machine tool in which the principal motion is the rotation of the workpiece against the stationary cutting tool(s) and where cutting energy is brought by the workpiece and not by the tool. This machine is controlled by a numerical control (NC) providing automatic functioning in accordance with ISO 13041-1:2004, 3.3, and can be of single spindle or multi-spindle type.

A turning centre is an NC turning machine equipped with power-driven tool(s) and the capacity to orientate the workholding spindle around its axis. This machine can include additional features, such as automatic tool changing from a magazine.

The objective of the ISO 13041 series is to supply as wide and comprehensive information as possible on geometric, positional, contouring, thermal and machining tests, which can be carried out for comparison, acceptance, maintenance or any other purpose.

The ISO 13041 series specifies, with reference to the relevant parts of ISO 230, tests for turning centres and numerically controlled turning machines with/without tailstocks, standing alone or integrated in flexible manufacturing systems. It also establishes the tolerances or maximum acceptable values for the test results corresponding to general purpose and normal accuracy turning centres and numerically controlled turning machines.

Test conditions for numerically controlled turning machines and turning centres —

Part 6: Accuracy of a finished test piece

1 Scope

This part of ISO 13041 specifies, with reference to ISO 230-1, a series of cutting tests, under finishing conditions, of standard test pieces. It also specifies the characteristics and dimensions of the test pieces themselves.

This part of ISO 13041 is intended to supply minimum requirements for assessing the cutting accuracy of the machine.

2 Normative references

The following referenced documents are indispensable for the application of this document. For dated references, only the edition cited applies. For undated references, the latest edition of the referenced document (including any amendments) applies.

ISO 230-1:1996, *Test code for machine tools — Part 1: Geometric accuracy of machines operating under no-load or finishing conditions*

ISO 1101, *Geometrical Product Specifications (GPS) — Geometrical tolerancing — Tolerances of form, orientation, location and run-out*

ISO 13041-1:2004, *Test conditions for numerically controlled turning machines and turning centres — Part 1: Geometric tests for machines with a horizontal workholding spindle*

ISO 13041-2, *Test conditions for numerically controlled turning machines and turning centres — Part 2: Geometric tests for machines with a vertical workholding spindle*

ISO 13041-3, *Test conditions for numerically controlled turning machines and turning centres — Part 3: Geometric tests for machines with inverted vertical workholding spindles*

3 Preliminary remarks

3.1 Measuring units

In this part of ISO 13041, all linear dimensions, deviations and corresponding tolerances are expressed in millimetres; angular dimensions are expressed in degrees, and angular deviations and the corresponding tolerances are expressed in ratios, but in some cases microradians or arcseconds may be used for clarification purposes. The equivalence of the following expressions should always be kept in mind.

$$0,010/1\ 000 = 10\ \mu\text{rad} \approx 2''$$

3.2 Reference to ISO 230-1

To apply this part of ISO 13041, reference shall be made to ISO 230-1, especially for the installation of the machine before testing, warming up of the machine, description of measuring methods, and evaluation and presentation of the results.

3.3 Test sequence

The sequence in which the tests are presented in this part of ISO 13041 in no way defines the practical order of testing.

3.4 Tests to be performed

When testing a machine, it is not always necessary or possible to carry out all the tests described in this part of ISO 13041. When the tests are required for acceptance purposes, it is up to the user to choose, in agreement with the supplier/manufacture, those tests relating to the components and/or the properties of the machine which are of interest. These tests are to be clearly stated when ordering a machine. Mere reference to this part of ISO 13041 for the acceptance tests, without specifying the tests to be carried out, and without agreement on the relevant expenses, cannot be considered as binding for any contracting party.

When testing machines with moving cross rail, the tolerances given in this part of ISO 13041 apply when the position of the cross rail is fixed at a certain location (preferably in mid-travel of the cross rail or some other predetermined position subject to agreement between the supplier/manufacture and the user).

3.5 Measuring instruments

The measuring instruments indicated in the tests described in Clause 4 are examples only. Other instruments measuring the same qualities and having at least the same accuracy may be used. Linear displacement sensors shall have a resolution of 0,001 mm or better. See ISO 14253-1, ISO/TS 14253-2 and ISO/TR 16015.

3.6 Fixing of test pieces

The test piece shall be conveniently mounted on a proper fixture or chuck, such that maximum stability of tools and fixture is achieved. The mounting surfaces of the fixture and the test piece shall be flat and/or cylindrical. It is recommended that suitable means of fixturing be used to allow for tool breakthrough (if applicable).

NOTE Fixing of the test piece can have a significant impact on the results of the tests. Therefore, parameters associated with fixing the test piece, such as type and number of jaws, and amount of clamping force, are considered carefully.

3.7 Materials of test pieces, tooling and cutting parameters

The test piece material, tooling and the subsequent cutting parameters are subject to agreement between supplier/manufacture and user, and shall be recorded. The test piece material shall be specified with proper material designations.

3.8 Sizes of test pieces

If the test pieces are machined several times, with a consequent reduction of external dimensions, it is recommended that the final test piece, when used for acceptance purposes, comply with the dimensions specified in this part of ISO 13041.

If the test pieces come from previous cutting tests and are re-useable, their characteristic dimensions shall remain within 10 % of those indicated in this part of ISO 13041. When the test pieces are re-used, a shallow cut shall be made to clean up all surfaces before new finishing test cuts are taken.

It is also recommended that type and serial number of the machine, date of test and names and orientation of the axes be marked on the test pieces and that they be delivered with the machine for reference purposes.

In principle, no more than one piece of each type shall be machined for acceptance purposes. In case of special requirements, such as statistical assessment of the machine performance, the machining of more test pieces is to be subject to agreement between the supplier/manufacturer and user.

Preliminary cuts shall be taken in order to make the depth of cut as constant as possible.

3.9 Information to be recorded

For tests made according to the requirements of this part of ISO 13041, the following information shall be compiled as completely as possible and shall be included in the test report:

- a) material and dimensions of the test piece;
- b) material and dimensions of the tool;
- c) cutting speed(s);
- d) feedrate(s) (feed velocity);
- e) depth(s) of cut;
- f) axes used for machining;
- g) test piece fixing conditions;
- h) other cutting parameters, e.g. cutting fluid.

3.10 Machine size categories

For the purposes of the ISO 13041 series, machines are classified into size categories depending on their work spindle orientation (see ISO 13041-1 for horizontal workholding spindle, ISO 13041-2 for vertical workholding spindle, and ISO 13041-3 for inverted vertical workholding spindle).

The categories and size ranges are referenced in the cutting tests of this part of ISO 13041 and are therefore repeated here for the convenience of the user.

ISO 13041-1 NC turning machines and turning centres with horizontal workholding spindle are classified into three size categories, on the basis of the criteria specified in Table 1.

Table 1 — Size range for machines with horizontal workholding spindle

Criteria	Category 1	Category 2	Category 3
Swing diameter over bed	$D \leq 250$	$250 < D \leq 500$	$500 < D \leq 1\ 000$
Nominal bar diameter	$d' \leq 25$	$25 < d' \leq 63$	$63 < d'$
Nominal diameter of chuck	$d \leq 125$	$125 < d \leq 250$	$250 < d$

NOTE 1 The nominal chuck diameter is defined in ISO 3442-1 and ISO 3442-2.

NOTE 2 The choice of criteria is at the manufacturer's discretion.

ISO 13041-2 NC turning machines and turning centres with vertical workholding spindles are classified into four categories, on the basis of the criteria specified in Table 2.

Table 2 — Size ranges for machines with vertical workholding spindle

Criteria	Category 1	Category 2	Category 3	Category 4
Nominal diameter of chuck	$d \leq 500$	$500 < d \leq 1\,000$	$1\,000 < d \leq 5\,000$	$d > 5\,000$
Diameter of workholding spindle/table	$D \leq 500$	$500 < D \leq 1\,000$	$1\,000 < D \leq 5\,000$	$D > 5\,000$

NOTE 3 The nominal chuck diameter is defined in ISO 3442-1 and ISO 3442-2.

ISO 13041-3 NC turning machines and turning centres with inverted vertical workholding spindle are classified into three size categories, on the basis of the criteria specified in Table 3.

Table 3 — Size ranges for machines with inverted vertical workholding spindle

Criteria	Category 1	Category 2	Category 3
Nominal diameter of chuck	$d \leq 250$	$250 < d \leq 400$	$d > 400$
Maximum turning diameter	$D \leq 315$	$315 < D \leq 500$	$D > 500$

NOTE 4 The nominal chuck diameter is defined in ISO 3442-1 and ISO 3442-2.

4 Machining tests

Object Turning a cylindrical test piece: a) circularity; b) consistency of machined diameters.		M1																																																															
Diagram 																																																																	
Key 1 chuck <i>l</i> shall be chosen to suit the measuring instrument. The distance between the chuck face and the first step, ϕD_p , shall be less than <i>L</i> .																																																																	
For machines with horizontal workholding spindle (ISO 13041-1): For bar machines: $L = 2,5 \times d'$ (nominal bar diameter) $D_{p, \min} = 0,3 \times L$; For chucking machines: $L = 0,8 \times d$ (nominal chuck diameter), or $L = 0,66 \times$ maximum turning length (Z stroke), whichever is smaller. $D_{p, \min} = 0,3 \times L$		For machines with vertical workholding spindle (ISO 13041-2) or inverted vertical workholding spindle (ISO 13041-3): $L = 0,8 \times d$ (nominal chuck diameter), or $L = 0,66 \times$ maximum turning length (Z stroke), whichever is smaller. $L_{\max} = 1\ 500$ $D_{p, \min} = 0,3 \times L$ $D_{p, \max} = 1\ 000$																																																															
<table border="1"> <thead> <tr> <th rowspan="3">Tolerance</th> <th colspan="3">Machines with horizontal spindle (ISO 13041-1)</th> <th colspan="4">Machines with vertical spindle (ISO 13041-2)^a</th> <th colspan="3">Machines with inverted vertical spindle (ISO 13041-3)</th> <th rowspan="3">Measured deviation Machine class and category: a) b)</th> </tr> <tr> <th colspan="3">Category</th> <th colspan="4">Category</th> <th colspan="3">Category</th> </tr> <tr> <th>1</th> <th>2</th> <th>3</th> <th>1</th> <th>2</th> <th>3</th> <th>4</th> <th>1</th> <th>2</th> <th>3</th> </tr> </thead> <tbody> <tr> <td>a) Circularity</td> <td>0,005</td> <td>0,005</td> <td>0,005</td> <td>0,005</td> <td>0,005</td> <td>0,01</td> <td>0,015</td> <td>0,005</td> <td>0,005</td> <td>0,005</td> <td></td> </tr> <tr> <td>b) Consistency of diameters</td> <td>0,01</td> <td>0,015</td> <td>0,02</td> <td>0,015</td> <td>0,02</td> <td>0,03</td> <td>0,04</td> <td>0,01</td> <td>0,015</td> <td>0,02</td> <td></td> </tr> </tbody> </table>										Tolerance	Machines with horizontal spindle (ISO 13041-1)			Machines with vertical spindle (ISO 13041-2) ^a				Machines with inverted vertical spindle (ISO 13041-3)			Measured deviation Machine class and category: a) b)	Category			Category				Category			1	2	3	1	2	3	4	1	2	3	a) Circularity	0,005	0,005	0,005	0,005	0,005	0,01	0,015	0,005	0,005	0,005		b) Consistency of diameters	0,01	0,015	0,02	0,015	0,02	0,03	0,04	0,01	0,015	0,02	
Tolerance	Machines with horizontal spindle (ISO 13041-1)			Machines with vertical spindle (ISO 13041-2) ^a				Machines with inverted vertical spindle (ISO 13041-3)			Measured deviation Machine class and category: a) b)																																																						
	Category			Category				Category																																																									
	1	2	3	1	2	3	4	1	2	3																																																							
a) Circularity	0,005	0,005	0,005	0,005	0,005	0,01	0,015	0,005	0,005	0,005																																																							
b) Consistency of diameters	0,01	0,015	0,02	0,015	0,02	0,03	0,04	0,01	0,015	0,02																																																							
^a Tolerances apply only to machines with fixed cross rail. Tolerances for machines with adjustable height cross rails will depend on the method of locating and/or adjusting the cross rail after raising or lowering and should be agreed between the supplier and the user.																																																																	
Measuring instruments For a), roundness measuring machine. For b), micrometer.																																																																	
Observations and references to ISO 230-1:1996, 4.1, 6.6 and 6.8 For b), readings are taken at each band in one plane only, the variation of the readings between adjacent bands shall not exceed 75 % of the tolerance. The machine axes used shall be recorded.																																																																	
NOTE A thick walled tube instead of a solid rod can be used as the cylindrical test blank.																																																																	

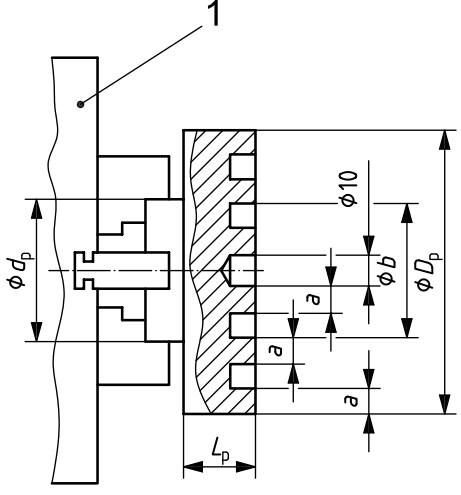
Object Checking the flatness of surfaces perpendicular to the spindle axis.		M2					
Diagram 	<p>Machines with horizontal workholding spindles (ISO 13041-1) and inverted vertical workholding spindles (ISO 13041-3):</p> <p>$D_p = 0,8 \times$ nominal diameter of chuck, or</p> <p>$D_p = 1 \times$ nominal bar diameter</p> <p>$D_{p,max} = 300$</p> <p>For $D_p < 160$, middle ring may be eliminated.</p> <p>For $D_p < 60$ all grooves may be omitted.</p> <p>$L_p = 0,25 \times$ nominal chuck diameter</p> <p>$L_{p,max} = 60$</p> <p>$d_p = 0,5 \times D$ or nominal bar diameter</p> <p>$d_{p,min} = 75$ (for chucking machines)</p> <p>$b = D_p/2 - a$</p>		<p>Machines with vertical workholding spindles (ISO 13041-2):</p> <p>$D_p = 0,8 \times$ nominal diameter of chuck</p> <p>$D_{p,max} = 300$ (Category 1)</p> <p>$= 400$ (Category 2)</p> <p>$= 800$ (Category 3)</p> <p>$= 1\ 500$ (Category 4)</p> <p>$d_p = 0,5 \times D_p$</p> <p>(when part is chucked to prevent part distortion)</p> <p>$L_p = 0,25 \times$ nominal diameter of chuck</p> <p>$L_{p,max} = 300$</p> <p>$b = D_p/2 - a$</p>				
	Key 1 chuck						
Dimension <i>a</i> shall be chosen to suit the measuring instrument.							
NOTE The nominal diameter of chuck is defined in ISO 3442-1 and ISO 3442-2.							
Tolerance	Machines with horizontal spindle (ISO 13041-1) and machines with inverted vertical spindle (ISO 13041-3)		Machines with vertical spindle (ISO 13041-2) ^a				
	Category		Category				
	1	2	3	1	2	3	4
Flatness	0,010	0,015	0,020	0,015	0,02	0,03	0,04
^a Tolerances apply only to machines with fixed cross rail. Tolerances for machines with adjustable height cross rails will depend on the method of locating and/or adjusting the cross rail after raising or lowering and should be agreed between the supplier and the user.				Measured deviation Machine class and category:			
Measuring instruments Linear displacement sensor, surface plate or coordinate measuring machine (CMM).							
Observations and references to ISO 230-1:1996 , 4.1 and 5.321.1 Measurements shall be recorded from at least two diameters. Any deviation shall not result in a convex surface except by special agreement. The machine axes used shall be recorded.							

Object

Checking of positioning and contouring capability of the machine under various kinematic conditions.

M3

This test applies to all NC turning centres described in ISO 13041 with live spindle tooling. Test piece designation (size) to be machined and the axis combination to be used for machining for acceptance purposes shall be agreed between the supplier/manufacturer and the user.

Diagram

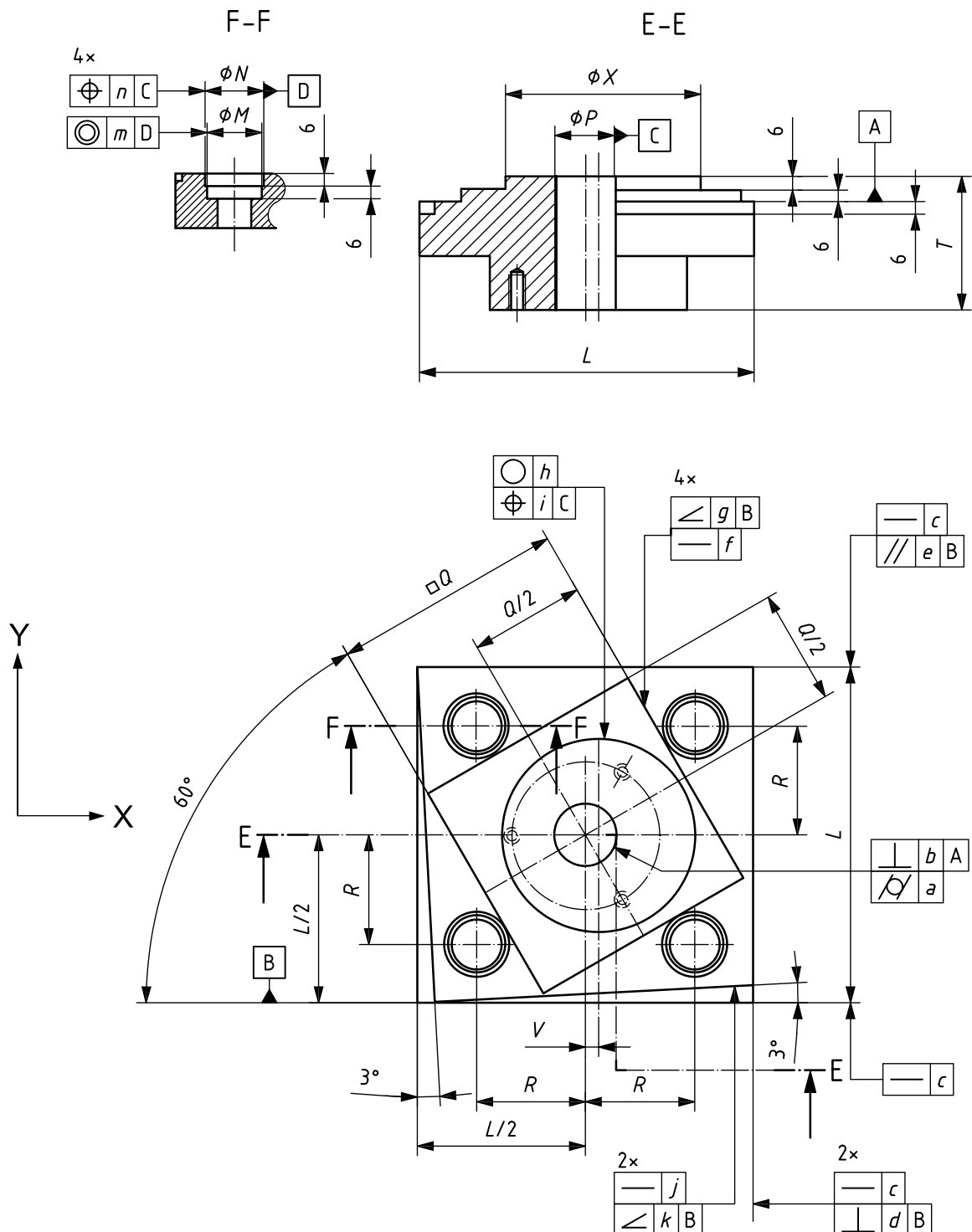

Dimensions L to Z are given in Table 4.

See Figure 1 for details of the pre-machined blank.

Tolerance Tolerances <i>a</i> to <i>m</i> are given in Table 5.	Measured deviations See Table 5
Measuring instruments See Table 5.	
Observations and references to ISO 230-1:1996, 5.211 Each straight side (of the square, diamond and sloping faces) shall be measured at at least 10 points to obtain the straightness, squareness and parallelism deviations. For the circularity (or cylindricity) test, if the measurement is not continuous, check at least 15 points (for cylindricity in each measured plane). For circularity, continuous measurements with no filtering is recommended. All features of the test piece shall be machined using either the C- and X-axes or the X- and Y-axes (using only two axes). If the test piece is machined with an interpolation of the spindle and a linear axis (e.g. X and C), there shall be no intermediate movement of any other linear axes (e.g. Y). If the test piece is machined with two linear axes of sufficient travel (e.g. X and Y), there shall be no intermediate movements of the spindle holding the test piece. Both options require synchronized axes motion at slow speeds, similar to the motions required to machine the 3° sloped faces. For a machine with an optional Y-axis, the axis pair is subject to agreement between the manufacturer and the user and is noted on the test report.	

Table 4 — Test piece M3 and test blank dimensions

Dimension	Test piece designation		
	ISO 13041-6-M3-80	ISO 13041-6-M3-160	ISO 13041-6-M3-320
L^a	80	160	320
$\varnothing M^b$	14	26	43
$\varnothing N^b$	16	28	45
$\varnothing P^c$	16	30	50
Q^d	54	110	220
R	27	52	110
$\varnothing S$	55	110	240
T	50	50	80
U	20	20	40
V	2	5	9
$\varnothing X^e$	50	96	202
Y	42	90	200
Z	M6 × 1; 10 Deep	M8 × 1,25; 12 Deep	M12 × 1,5; 20 Deep

^a An external square with side length “*L*”.

^b Four bored holes $\varnothing M$ and four counterbored holes $\varnothing N$. The holes $\varnothing M$ shall be approached in the positive direction of the positioning axes; the holes $\varnothing N$ shall be approached in the negative direction. The location of these bores are “R-R” from the centre of the test piece.

^c A through-bored hole $\varnothing P$ located in the centre of the test piece.

^d Diamond (square inclined by 60°) with side length “*Q*”, on the upper face of the square. It should only be machined when two linear axes are used (e.g. X and Y). In this case, the circle (diameter *X*) will be 12 mm high on the upper face of the outer square *L*.

^e Circle with $\varnothing X$, 6 mm high on the upper face of the diamond. The centre of the circle $\varnothing X$ shall be dimension “*V*” eccentric to centre bore $\varnothing P$ in the X-axis direction.

On turning centres without an optional Y-axis, this circle shall be machined by rotating the C-axis past the periphery of an end mill whilst feeding the X-axis into the test piece for 180° of C-axis rotation followed by reversing the direction of the X-axis to complete 360° of the C-axis rotation while maintaining the same contouring feedrate. (This X-axis motion will create a circle that is “*V*” eccentric to the C-axis centre of rotation and a lead of approximately 3° to the instantaneous tangent of the circle.)

Sloping faces, on the full length of the two sides of the external square, with an angle of 3° or providing a tangent of 0,05 and 6 mm depth on the top of the external square sides. These faces should only be machined when two linear axes are used (e.g. X and Y).

Table 5 — Test M3 geometric tests

Tolerances	Object	Tolerance Test piece designation			Measuring instrument	Measured deviation
		ISO 13041-6- M3-80	ISO 13041-6- M3-160	ISO 13041-6- M3-320		
<i>a</i> <i>b</i>	CENTRAL HOLE $\varnothing P$					
	Cylindricity	0,010	0,010	0,015	CMM or roundness tester	<i>a</i>
	Squareness between the hole axis and datum A	0,010	0,010	0,015	CMM or roundness tester	<i>b</i>
<i>c</i> <i>d</i> <i>e</i>	SQUARE $L \times L$					
	Straightness of the sides	0,030	0,030	0,045	CMM or straight-edge and linear displacement sensor	<i>c</i>
	Squareness of the adjacent sides to datum B	0,040	0,040	0,060	CMM or square and linear displacement sensor	<i>d</i>
	Parallelism of the opposite side to datum B	0,040	0,040	0,060	CMM or height gauge or linear displacement sensor	<i>e</i>
<i>f</i> <i>g</i>	DIAMOND^a $Q \times Q$					
	Straightness of the sides	0,030	0,030	0,045	CMM or straight-edge and linear displacement sensor	<i>f</i>
	Accuracy of 60° angles to datum B	0,040	0,040	0,060	CMM or sine bar and linear displacement sensor	<i>g</i>
<i>h</i> <i>i</i>	CIRCLE $\varnothing X$					
	Circularity	0,030	0,030	0,040	CMM or roundness measuring instruments	<i>h</i>
	True position of the external circle relative to datum C	0,040	0,040	0,050	CMM	<i>i</i>
<i>j</i> <i>k</i>	SLOPING FACES					
	Straightness of the faces	0,030	0,030	0,045	CMM or straight-edge and linear displacement sensor	<i>j</i>
	Accuracy of the angles to datum B	0,040	0,040	0,060	CMM or sine bar and linear displacement sensor	<i>k</i>
<i>m</i> <i>n</i>	BORED HOLES					
	Concentricity of inner holes "N" to outer holes "M"	0,020	0,020	0,020	CMM or roundness measuring instruments	<i>m</i>
	True position of holes "N" relative to datum C	$\varnothing 0,05$	$\varnothing 0,05$	$\varnothing 0,05$	CMM	<i>n</i>

^a Diamond is only machined when two linear axes are used (e.g. X and Y).

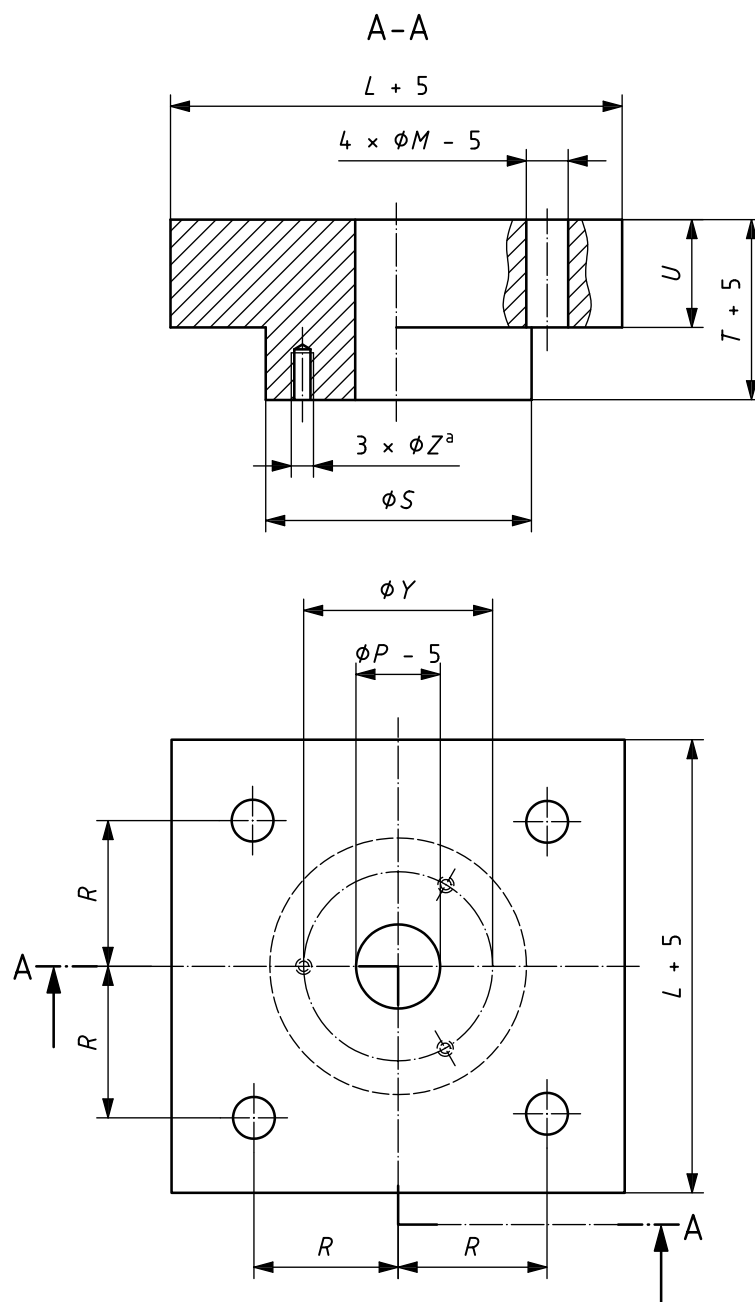

NOTE 1 For dimensions L, M, P, R, S, T, U, Y and Z , see Table 4.

NOTE 2 The tapped holes "Z" are optional and are used for securing the test piece blank to a sub-plate on turning centres having no suitable workholding chuck (i.e. vertical turning centres). In such cases, for proper mounting, the bottom surface of the test piece shall be flat.

^a On Y pitch diameter.

Figure 1 — Test M3 pre-machined blank

Object

M4

Checking the circular deviation of a 100° arc on a test piece (in accordance with ISO 1101).

This test applies to all NC turning machines and turning centres described in ISO 13041. The test piece designation (size) to be machined for acceptance purposes shall be agreed between the supplier and the user.

Diagram

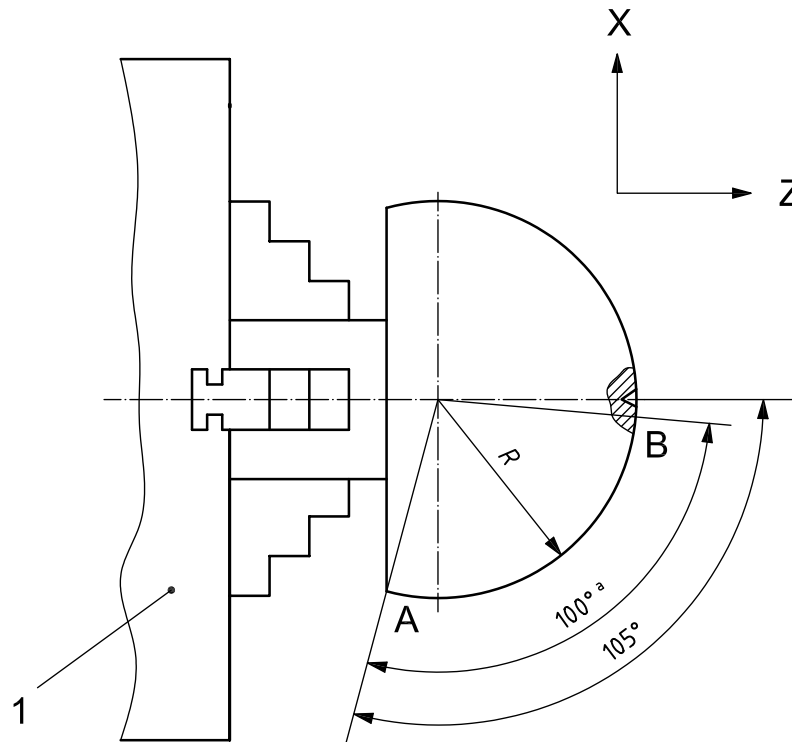

Key

- 1 chuck
- a Measured arc.

Tolerance	Test piece designation: ISO 13041-6-:		
	M4-50	M4-100	M4-150
Nominal radius, <i>R</i>	50	100	150
Circular deviation tolerance	0,025	0,045	0,070

Measured deviation

Test piece machined:
ISO 13041-6-M4-...

Measuring instruments

Coordinate measuring machine; profile projector.

Observations and references to ISO 230-1:1996, 6.61 and 6.622

Circular deviations shall be measured over the 100° measurement range in continuous measuring mode starting at position A and finishing at position B. Positions A and B are shown in the diagram above.

The hemisphere pole shall not be included in the measured arc.

Variations shall be presented in a graphical form.

NOTE 1 Rotation of the measurement plane about the part centre line can yield different results due to possible spindle axis of rotation errors.

Programmed radius, *R*, and measurement method shall be reported.

NOTE 2 The test piece can be re-used. However, the programmed radius should not differ more than ± 10 % from the nominal radius.

Bibliography

- [1] ISO 3442-1, *Machine tools — Dimensions and geometric tests for self-centring chucks with two-piece jaws — Part 1: Manually operated chucks with tongue and groove type jaws*
- [2] ISO 3442-2, *Machine tools — Dimensions and geometric tests for self-centring chucks with two-piece jaws — Part 2: Power-operated chucks with tongue and groove type jaws*
- [3] ISO 14253-1, *General Product Specifications (GPS) — Inspection by measurement of workpieces and measuring equipment — Part 1: Decision rules for proving conformance or non-conformance with specifications*
- [4] ISO/TS 14253-2, *Geometrical Product Specifications (GPS) — Inspection by measurement of workpieces and measuring equipment — Part 2: Guide to the estimation of uncertainty in GPS measurement, in calibration of measuring equipment and in product verification*
- [5] ISO/TR 16015, *Geometrical Product Specifications (GPS) — Systematic errors and contributions to measurement uncertainty of length measurement due to thermal influences*

ICS 25.040.20

Price based on 12 pages

BSI - British Standards Institution

BSI is the independent national body responsible for preparing British Standards. It presents the UK view on standards in Europe and at the international level. It is incorporated by Royal Charter.

Revisions

British Standards are updated by amendment or revision. Users of British Standards should make sure that they possess the latest amendments or editions.

It is the constant aim of BSI to improve the quality of our products and services. We would be grateful if anyone finding an inaccuracy or ambiguity while using this British Standard would inform the Secretary of the technical committee responsible, the identity of which can be found on the inside front cover. Tel: +44 (0)20 8996 9000. Fax: +44 (0)20 8996 7400.

BSI offers members an individual updating service called PLUS which ensures that subscribers automatically receive the latest editions of standards.

Buying standards

Orders for all BSI, international and foreign standards publications should be addressed to Customer Services. Tel: +44 (0)20 8996 9001. Fax: +44 (0)20 8996 7001 Email: orders@bsigroup.com You may also buy directly using a debit/credit card from the BSI Shop on the Website <http://www.bsigroup.com/shop>

In response to orders for international standards, it is BSI policy to supply the BSI implementation of those that have been published as British Standards, unless otherwise requested.

Information on standards

BSI provides a wide range of information on national, European and international standards through its Library and its Technical Help to Exporters Service. Various BSI electronic information services are also available which give details on all its products and services. Contact Information Centre. Tel: +44 (0)20 8996 7111 Fax: +44 (0)20 8996 7048 Email: info@bsigroup.com

Subscribing members of BSI are kept up to date with standards developments and receive substantial discounts on the purchase price of standards. For details of these and other benefits contact Membership Administration. Tel: +44 (0)20 8996 7002 Fax: +44 (0)20 8996 7001 Email: membership@bsigroup.com

Information regarding online access to British Standards via British Standards Online can be found at <http://www.bsigroup.com/BSOL>

Further information about BSI is available on the BSI website at <http://www.bsigroup.com>

Copyright

Copyright subsists in all BSI publications. BSI also holds the copyright, in the UK, of the publications of the international standardization bodies. Except as permitted under the Copyright, Designs and Patents Act 1988 no extract may be reproduced, stored in a retrieval system or transmitted in any form or by any means – electronic, photocopying, recording or otherwise – without prior written permission from BSI.

This does not preclude the free use, in the course of implementing the standard, of necessary details such as symbols, and size, type or grade designations. If these details are to be used for any other purpose than implementation then the prior written permission of BSI must be obtained.

Details and advice can be obtained from the Copyright and Licensing Manager. Tel: +44 (0)20 8996 7070 Email: copyright@bsigroup.com