

# Copper, lead, and zinc sulfide concentrates — Determination of transportable moisture limits — Flow-table method

ICS 73.060.99

## National foreword

This British Standard is the UK implementation of ISO 12742:2007.

The UK participation in its preparation was entrusted to Technical Committee NFE/36, Copper, lead and zinc ores and concentrates.

A list of organizations represented on this committee can be obtained on request to its secretary.

This publication does not purport to include all the necessary provisions of a contract. Users are responsible for its correct application.

**Compliance with a British Standard cannot confer immunity from legal obligations.**

This British Standard was published under the authority of the Standards Policy and Strategy Committee on 31 August 2007

© BSI 2007

ISBN 978 0 580 56423 9

### Amendments issued since publication

Amd. No.	Date	Comments

INTERNATIONAL  
STANDARD

ISO  
12742

Second edition  
2007-07-01

---

---

**Copper, lead, and zinc sulfide  
concentrates — Determination of  
transportable moisture limits —  
Flow-table method**

*Concentrés sulfurés de cuivre, de plomb et de zinc — Détermination  
des limites d'humidité transportable — Méthode de la table  
d'écoulement*



Reference number  
ISO 12742:2007(E)



# Contents

Page

Foreword.....	iv
Introduction .....	v
1 Scope .....	1
2 Normative references .....	1
3 Principle.....	1
4 Apparatus .....	1
5 Sampling and sample preparation .....	2
5.1 General.....	2
5.2 Laboratory sample.....	3
5.3 Sample preparation .....	3
6 Procedure .....	3
6.1 General.....	3
6.2 Preparation of test portions.....	4
6.2.1 General.....	4
6.2.2 Filling the mould .....	4
6.2.3 Tamping pressure.....	4
6.2.4 Tamping procedure .....	5
6.2.5 Removal of the mould .....	5
6.2.6 Dropping the flow table.....	5
6.3 Identification of the flow state .....	5
6.4 Preliminary flow moisture point.....	7
6.4.1 Preparation of test portion.....	7
6.4.2 Determination of preliminary flow moisture point .....	7
6.4.3 Addition of water for preliminary flow moisture point test .....	8
6.5 Main flow moisture point determination .....	8
6.5.1 Preparation of test portions.....	8
6.5.2 Determination of main flow moisture point .....	8
6.5.3 Addition of water for main flow moisture point determination .....	8
6.6 Graphical method .....	8
6.6.1 Preparation of test portions.....	8
6.6.2 Determination of flow moisture point .....	9
6.7 Moisture determination .....	9
7 Expression of results .....	9
7.1 Main flow moisture point .....	9
7.2 Flow moisture point determined by the graphical method .....	9
8 Validation of main flow moisture point .....	10
9 Test report .....	10
Annex A (normative) Description of equipment used to determine TML.....	11
Bibliography .....	18

## Foreword

ISO (the International Organization for Standardization) is a worldwide federation of national standards bodies (ISO member bodies). The work of preparing International Standards is normally carried out through ISO technical committees. Each member body interested in a subject for which a technical committee has been established has the right to be represented on that committee. International organizations, governmental and non-governmental, in liaison with ISO, also take part in the work. ISO collaborates closely with the International Electrotechnical Commission (IEC) on all matters of electrotechnical standardization.

International Standards are drafted in accordance with the rules given in the ISO/IEC Directives, Part 2.

The main task of technical committees is to prepare International Standards. Draft International Standards adopted by the technical committees are circulated to the member bodies for voting. Publication as an International Standard requires approval by at least 75 % of the member bodies casting a vote.

Attention is drawn to the possibility that some of the elements of this document may be the subject of patent rights. ISO shall not be held responsible for identifying any or all such patent rights.

ISO 12742 was prepared by Technical Committee ISO/TC 183, *Copper, lead, zinc and nickel ores and concentrates*.

This second edition cancels and replaces the first edition (ISO 12742:2000), which has been technically revised.

## Introduction

ISO 12742:2000 was published as a guidance document because there had been insufficient test programme participants to allow precision data to be derived. However, it had been agreed that ISO/TC 183/WG 11 be kept in existence, as there was likelihood that a precision test programme could be held at a later time.

Revision of ISO 12742 was commenced in 2005, on the basis that changes to the procedure were necessary, and there were then sufficient participants to allow a test programme to be conducted.

In the final analysis, insufficient participants were identified. However, the International Standard has been revised for a further edition as a guidance document.





# Copper, lead, and zinc sulfide concentrates — Determination of transportable moisture limits — Flow-table method

**WARNING** — This International Standard may involve hazardous materials, operations and equipment. It is the responsibility of the user of this International Standard to establish appropriate health and safety practices and determine the applicability of regulatory limitations prior to use.

## 1 Scope

This International Standard specifies a flow-table method for the determination of the transportable moisture limit (TML) of copper, lead and zinc sulfide concentrates, which may liquefy during transport.

This International Standard is applicable to the determination of the TML of concentrates containing 10 % to 80 % (mass fraction) of lead, or 10 % to 65 % (mass fraction) of zinc, or 10 % to 55 % (mass fraction) of copper. It is applicable to TMLs in the range 3 % to 28 % (mass fraction).

## 2 Normative references

The following referenced documents are indispensable for the application of this document. For dated references, only the edition cited applies. For undated references, the latest edition of the referenced document (including any amendments) applies.

ISO 10251, *Copper, lead, zinc and nickel concentrates — Determination of mass loss of bulk material on drying*

ISO 12743, *Copper, lead, zinc and nickel concentrates — Sampling procedures for determination of metal and moisture content*

## 3 Principle

The moisture content of the sample is adjusted by mixing with water. The mixture is converted to a conical shape using a mould and tamper. The sample is placed on the flow table and the mould is removed. The flow characteristics are determined by repeated dropping of the flow table, while observing the behaviour of the sample. When sufficient water has been added to the sample so that plastic deformation occurs during the dropping of the flow table, the sample is considered to be at its flow moisture point.

The TML is calculated as 90 % of the flow moisture point.

## 4 Apparatus

Copper, lead and zinc concentrates may gain or lose moisture rapidly when exposed to air. The laboratory should be designed so that excessive temperatures, direct sunlight, air currents and humidity variations are avoided.

### 4.1 Flow table and frame, as specified in Annex A.

The flow-table mounting shall be as specified in Figure A.1.

4.2 **Mould**, as specified in Figure A.1.

4.3 **Tamper**.

The required tamping pressure may be achieved by using calibrated, spring-loaded tampers or some other suitable design of tamper that allows a controlled pressure to be applied via a 30 mm diameter tamper head as specified in Figure A.2.

4.4 **Calliper ruler**.

4.5 **Balance**, top loading, having the sensitivity specified in Table 1.

**Table 1 — Sensitivity of balance and precision of weighing**

Mass of sample plus tray g	Precision of balance and weighing g
100	0,01
200	0,02
300	0,03
400	0,04
500	0,05

4.6 **Measuring cylinder**, of capacity 50 ml to 200 ml.

4.7 **Burette**, of capacity 10 ml.

4.8 **Mixing bowl**, hemispherical, of diameter approximately 30 cm.

NOTE It is advisable to use an automatic mechanical mixer having a mixing bowl as described, as this leads to improved precision.

4.9 **Rubber gloves**.

4.10 **Drying trays or pans**, having dimensions that permit the sample to be spread to a thickness of less than 30 mm.

The trays shall be made of corrosion-resistant and heat-resistant material, such as stainless steel, glass or enamel plate.

4.11 **Drying oven**, ventilated, with forced circulation of air or inert gas, regulated at a temperature of 105 °C ± 5 °C.

4.12 **Airtight containers**.

## 5 Sampling and sample preparation

### 5.1 General

TML figures are required to be updated on a periodic basis, usually six monthly, or when there is a known change to the process used to produce the material. The reported figure should be the mean of samples taken during the period.

To ensure that the TML result is representative, increments of the material shall be taken either

- a) while a stockpile is being built up or broken down, or
- b) while loading or discharging a vessel.

These increments are combined to form the sample used to determine TML.

The sample used to determine TML should not be used to determine moisture.

Stationary sampling of stockpiles should never be used for the determination of TML. This method of sampling can only be used to provide an indicative moisture value for use during the planning of shipping schedules.

## 5.2 Laboratory sample

Samples for the determination of TML shall be taken in accordance with ISO 12743. The laboratory sample shall not weigh less than 12 kg. To minimize changes to the flow characteristics of the sample, it shall not be oven dried or ground during its preparation.

## 5.3 Sample preparation

Homogenize the laboratory sample as quickly as possible to prevent losses. Take nine test samples as follows:

- a) Sample 1

Take not less than 1 kg, which is to be used for determining the moisture content of the sample "as received", from the laboratory sample and place on a drying tray or pan.

- b) Sample 2

Take approximately 1,2 kg from the laboratory sample. This sample is to be used for the preliminary TML test. Store this sample in an appropriately labelled airtight container.

- c) Samples 3 to 6

Take four samples of approximately 1,2 kg from the laboratory sample. These samples are to be used for the main TML test. Store these samples in appropriately labelled airtight containers.

- d) Samples 7 to 9

Take three samples of approximately 1,2 kg from the laboratory sample. These samples are to be used for confirmation of TML by the graphical method. Store these samples in appropriately labelled airtight containers.

## 6 Procedure

### 6.1 General

Copper, lead and zinc concentrates may undergo rapid changes in moisture when exposed to air, so all stages of the test should be accomplished in the shortest time period and shall definitely be completed within the day of commencement. Where possible, sample containers should be covered with plastic film or any other suitable airtight cover.

The moisture result from Sample 1 provides information about how far the material under test is from the flow moisture point.

As more accurate results are obtained when the moisture of the test portion is close to the flow moisture point, a preliminary test is carried out (Sample 2). The result of this test is used to adjust the moisture of the final test portion to 1 % to 2 % below (Samples 3 and 4) and above (Samples 5 and 6) the flow moisture point.

To check the main flow moisture point graphically, three more samples (Samples 7 to 9), having moisture values higher than the flow moisture point, are tested. The flow moisture point is the extrapolation to zero of the linear adjustment of the seven test portions. The value obtained this way will be used to validate the main flow moisture point.

## 6.2 Preparation of test portions

### 6.2.1 General

Sample 1 is prepared in accordance with ISO 10251. Proceed to 6.7.

Samples 2 to 9 are prepared in accordance with 6.2.2 to 6.2.6.

### 6.2.2 Filling the mould

Place the mould on the centre of the flow table and fill it in three stages with the test portion as follows:

- a) the first charge, after tamping, shall aim to fill the mould to approximately one-third of its depth;
- b) the second charge, after tamping, shall fill the mould to about two-thirds of its depth;
- c) the third and final charge, after tamping, shall reach to just below the top of the mould (see Figure 1).

The quantity of test portion required to achieve each of these stages will vary from one material to another, but is readily established after experience has been gained on the packing characteristics of the material being tested.

### 6.2.3 Tamping pressure

The aim of tamping is to simulate the amount of compaction prevailing at the bottom of a shipboard cargo for the material being tested. The correct pressure to be applied via the tamper is calculated as follows:

$$p_T = \rho_D \times d_{\max} \times g \quad (1)$$

where

$p_T$  is the tamping pressure, in pascals;

$\rho_D$  is the bulk density, in kilograms per cubic metre;

$d_{\max}$  is the maximum depth of the cargo, in metres;

$g$  is the acceleration due to gravity (= 9,81 m/s<sup>2</sup>).

If, when calculating the tamping pressure, there is no information available concerning the cargo depth, use the maximum likely depth.

Alternatively, the pressure may be estimated from Table 2.

Table 2 — Tamping pressures (kPa) for selected concentrates<sup>a</sup>

Typical concentrate type	Bulk density kg/m <sup>3</sup>	Maximum cargo depth			
		2 m	5 m	10 m	20 m
Copper	2 000	39 [2,8]	98 [6,9]	196 [13,9]	392 [27,7]
Lead	2 100	41 [2,9]	103 [7,3]	206 [14,6]	412 [29,1]
Zinc	1 950	38 [2,7]	96 [6,8]	192 [13,5]	384 [27,1]

<sup>a</sup> Values in square brackets are equivalent kilogram-force (kgf) when applied via a 30 mm diameter tamper head.

#### 6.2.4 Tamping procedure

The number of tamping actions (applying the correct, steady pressure each time) should be about 35 for the bottom layer, 25 for the middle layer and 20 for the top layer. Tamping shall be performed successively over the complete area, including the edges of the sample, to form a uniform surface for each layer (see Figure 1).

#### 6.2.5 Removal of the mould

Tap the mould on its side until it becomes loose, leaving the material in the shape of a truncated cone on the flow table. Clean the surface of the table around the cone. Measure the size of the cone in the three directions marked on the table. The average of these readings will be equivalent to zero displacement.

#### 6.2.6 Dropping the flow table

Immediately after removing the mould, raise and drop the flow table up to 50 times through a height of  $12,5 \text{ mm} \pm 0,13 \text{ mm}$  at a rate of 25 times per minute. While the flow table is going through these cycles, observe the behaviour of the material using the information provided in 6.3 as a guide for determining the flow state.

### 6.3 Identification of the flow state

The impacting action of the flow table causes the grains of the material to rearrange themselves to produce compaction of the mass. As a result, the fixed volume of moisture contained in the material at any given level increases as a percentage of the total volume. A flow state is considered to have been reached when the moisture content and compaction of the material produce such a level of saturation that plastic deformation occurs. At this stage, the moulded sides of the cone may deform, giving a convex or concave profile (see Figure 2). With repeated action of the flow table, the cone continues to slump and to flow outwards. In certain materials, cracks may also develop on the top surface.



Figure 1 — Example of third stage of filling the mould



Figure 2 — Example of the material at the flow point

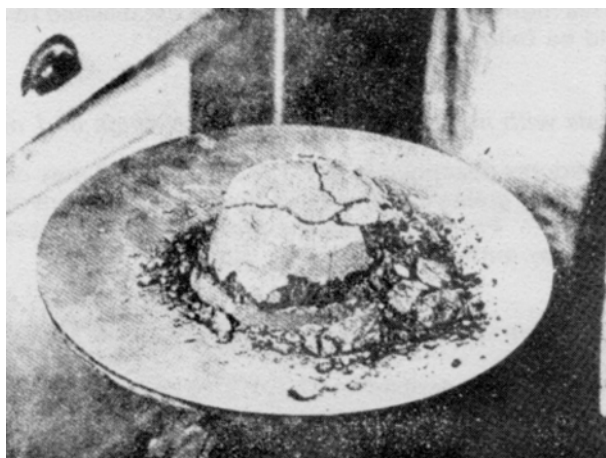
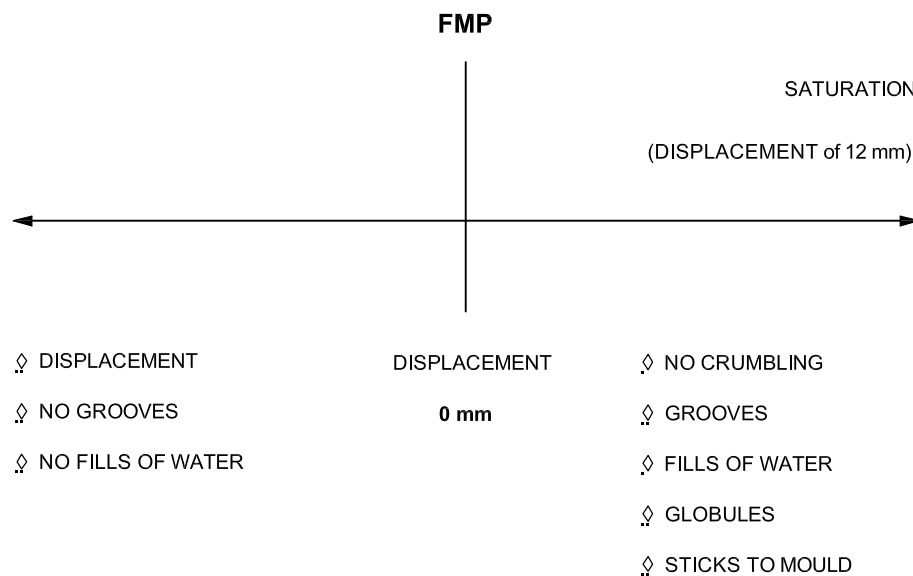

Figure 3 — Example of material crumbling but not at the flow point

Further criteria to use when determining if the flow state has been reached are as follows (see Figure 4).

- a) Cracking with the appearance of free moisture is not an indication of development of a flow state. In most cases, measurement of the deformation is helpful in deciding whether or not plastic flow has occurred. A template that, for example, will indicate an increase in diameter of up to 3 mm in any part of the cone is a useful guide for this purpose.
- b) Measuring the diameter of the cone, at the base or at half height, will always be useful. By addition of water in increments of 0,2 % to 0,3 % by mass and applying 25 drops of the flow table, the first diameter increase will generally be between 1 mm and 5 mm and, after a further increment in water, the base diameter would have expanded to between 5 mm and 10 mm.
- c) When the moisture content is approaching the flow moisture point (FMP), the cone begins to show a tendency to stick to the mould.
- d) When the cone is pushed off the table, it may leave tracks (stripes) of moisture on the table. If such stripes are seen, the moisture content may be above the flow moisture point. Slight deformation of the cone may appear at moisture contents lower than the flow moisture point, but in that case the test portion will leave no moisture tracks when removed.



**Figure 4 — Identification of the flow state**

## 6.4 Preliminary flow moisture point

### 6.4.1 Preparation of test portion

Prepare test portion 2 for the preliminary flow moisture point in accordance with 6.2.2 to 6.2.6.

### 6.4.2 Determination of preliminary flow moisture point

If the material exhibits any of the properties described in 6.3, then the flow moisture point has been reached. After the table has stopped, immediately measure the displacement of the test portion with a calliper ruler in the three directions marked on the table. Split the cone into two halves and place one-half in a pre-weighed drying tray or pan. Discard the other. Immediately weigh the test portion and tray and determine the moisture as described in 6.7.

If the material does not exhibit any of the properties described in 6.3, or simply crumbles and bumps off in fragments with successive drops of the table (see Figure 3), the flow moisture point has not been reached and more water needs to be added to the sample, as described in step 6.4.3.

#### 6.4.3 Addition of water for preliminary flow moisture point test

Once it has been ascertained that the material is not at the flow moisture point, stop the flow table and return test portion 2 to the mixing bowl. Add between 5 ml and 10 ml of water; if necessary, more water may be added. Thoroughly mix this added water into the material, either with rubber-gloved fingers or with an automatic mixer. Fill the mould again and repeat steps 6.4.1 to 6.4.2 until a flow state is reached.

NOTE The addition of water can also be achieved by measuring the mass of water added, rather than the volume of water.

### 6.5 Main flow moisture point determination

#### 6.5.1 Preparation of test portions

a) Samples 3 and 4

Once the preliminary flow moisture point has been determined, the moisture content of Samples 3 and 4 is adjusted by adding a volume of water that does not cause the flow moisture state (see 6.3). Prepare these test portions in accordance with 6.2.2 to 6.2.6.

b) Samples 5 and 6

To Samples 5 and 6, add a volume of water approximately equal to that for Samples 3 and 4, plus a volume of water equivalent to 0,2 % to 0,3 % of the mass of the test sample. Prepare these samples in accordance with 6.2.2 to 6.2.6.

#### 6.5.2 Determination of main flow moisture point

Determine if the desired state of each test portion has been reached according to 6.5.1 and 6.3. If not, go to 6.5.3. When the material exhibits the desired state, and once the whole dropping-table cycle has been completed, measure the displacement of the test portion with a calliper ruler in the three directions marked on the table. Take each half of the cone and place them in two pre-weighed drying trays or pans. Immediately weigh the test portion and tray and determine the moisture as described in 6.7.

If the material doesn't exhibit the properties expected, then more water needs to be added to the samples as described in the step in 6.5.3.

#### 6.5.3 Addition of water for main flow moisture point determination

Stop the flow table and return all the material to the mixing bowl. Add a volume of water equivalent to 0,2 % to 0,3 % of the mass of the test sample. Fill the mould again and repeat steps 6.5.1 to 6.5.2.

NOTE The addition of water can also be achieved by measuring the mass of water added, rather than the volume of water.

### 6.6 Graphical method

#### 6.6.1 Preparation of test portions

To Samples 7 to 9, add a quantity of water greater than the portion added to Samples 5 and 6 to cause a displacement not greater than 12 mm. To attain this, add a volume of water greater than the equivalent of 0,2 % to 0,3 % of the mass of the test sample used in the main flow moisture test. Prepare these test portions according to steps 6.2.2 to 6.2.6.



### 6.6.2 Determination of flow moisture point

After the table has stopped, measure the displacement of the test portion with a calliper ruler, in the three directions marked in the flow table. Take each half of the cone and place them in two pre-weighed drying trays or pans. Immediately weigh the test portion and tray and determine the moisture as described in 6.7.

### 6.7 Moisture determination

Determine the moisture content of all samples in accordance with ISO 10251.

## 7 Expression of results

### 7.1 Main flow moisture point

Calculate the flow moisture point using the following equation:

$$\text{FMP} = \frac{\frac{M_{31} + M_{32}}{2} + \frac{M_{41} + M_{42}}{2} + \frac{M_{51} + M_{52}}{2} + \frac{M_{61} + M_{62}}{2}}{4} \quad (2)$$

where

FMP is the flow moisture point, in percent (mass fraction);

$M_{31}$  is the mass fraction of moisture in the 1<sup>st</sup> half of test portion 3 (1<sup>st</sup> half of the cone), in percent;

$M_{32}$  is the mass fraction of moisture in the 2<sup>nd</sup> half of test portion 3 (2<sup>nd</sup> half of the cone), in percent;

$M_{41}$  is the mass fraction of moisture in the 1<sup>st</sup> half of test portion 4 (1<sup>st</sup> half of the cone), in percent;

$M_{42}$  is the mass fraction of moisture in the 2<sup>nd</sup> half of test portion 4 (2<sup>nd</sup> half of the cone), in percent;

$M_{51}$  is the mass fraction of moisture in the 1<sup>st</sup> half of test portion 5 (1<sup>st</sup> half of the cone), in percent;

$M_{52}$  is the mass fraction of moisture in the 2<sup>nd</sup> half of test portion 5 (2<sup>nd</sup> half of the cone), in percent;

$M_{61}$  is the mass fraction of moisture in the 1<sup>st</sup> half of test portion 6 (1<sup>st</sup> half of the cone), in percent;

$M_{62}$  is the mass fraction of moisture in the 2<sup>nd</sup> half of test portion 6 (2<sup>nd</sup> half of the cone), in percent.

Calculate the transportable moisture limit, to one decimal place, using the following equation:

$$\text{TML} = \text{FMP} \times 0,9 \quad (3)$$

where TML is the transportable moisture limit, in percent (mass fraction).

### 7.2 Flow moisture point determined by the graphical method

Plot displacement against the mean mass fraction of moisture in each test portion showing a measurable displacement. The flow moisture point is the moisture value for a line extrapolated to zero displacement.

## 8 Validation of main flow moisture point

The difference between the flow moisture point of 7.1 and the flow moisture point of 7.2 should not be greater than 0,5 % (mass fraction). If this happens, the value of the main flow moisture point should not be considered and the determination repeated.

## 9 Test report

The test report shall include the following information:

- a) identification of the sample;
- b) a reference to this International Standard, i.e. ISO 12742:2007;
- c) the transportable moisture limit (TML) of the sample, expressed as a percentage of the sample by mass;
- d) the mass fraction of moisture in the test portions, just above and just below the flow moisture point, expressed as a percentage of the sample.
- e) the tamping pressure used or simulated conditions attempted.

## Annex A (normative)

### Description of equipment used to determine TML

#### A.1 Scope

This annex describes the design of equipment suitable for determining the transportable moisture limit (TML) by the flow-table method.

#### A.2 Design requirements for the flow table and frame

The flow-table apparatus shall be constructed in accordance with Figure A.1. The apparatus shall consist of an integrally cast iron frame and a circular rigid table top  $254 \text{ mm} \pm 2,5 \text{ mm}$  in diameter, with a shaft attached perpendicular to the table top by means of a screw thread. The table top, to which the shaft with its integral contact shoulder is attached, shall be mounted on a frame in such a manner that it can be raised and dropped vertically through the specified height with a tolerance in height of  $\pm 0,13 \text{ mm}$  for new tables and  $\pm 0,39 \text{ mm}$  for tables in use, by means of a rotating cam. The table top shall have a fine machined plane surface, free of blowholes and surface defects, and this shall be described as shown in Figure A.1. The table top shall be of cast brass or bronze, having a Rockwell hardness number not less than HRB 25 with an edge thickness of 8 mm, and shall have six integral radial stiffening ribs. The table top and attached shaft shall weigh  $4 \text{ kg} \pm 0,05 \text{ kg}$  and the mass shall be symmetrical around the centre of the shaft.

The cam and vertical shaft shall be of medium-carbon tool steel, hardened as indicated in Figure A.1. The shaft shall be straight and the difference between the diameter of the shaft and the diameter of the bore of the frame shall be not less than 0,05 mm and not more than 0,08 mm for new tables, and shall be maintained at between 0,05 mm and 0,26 mm for tables in use. The end of the shaft shall not fall upon the cam at the end of the drop, but shall make contact with the cam not less than  $120^\circ$  from the point of drop. The face of the cam shall be a smooth spiralled curve of uniformly increasing radius from 13 mm to 32 mm in  $360^\circ$ , and there shall be no appreciable jar as the shaft comes into contact with the cam. The cam shall be so located and the contact faces of the cam and shaft shall be such that the table does not rotate more than one revolution in 25 drops. The surfaces of the frame and of the table which come into contact and the end of the drop shall be maintained smooth, plane, horizontal and parallel with the upper surface of the table, and shall make continuous contact over a full  $360^\circ$ .

The supporting frame of the flow table shall be integrally cast of fine-grain, high-grade cast iron. The frame casting shall have three integral stiffening ribs extending the full height of the frame and located  $120^\circ$  apart. The top of the frame shall be chilled to a depth of approximately 6,4 mm and the face shall be ground and lapped square with the bore to give  $360^\circ$  contact with the shaft shoulder. The underside of the base of the frame shall be ground to secure a complete contact with the steel plate beneath.

The flow table may be driven by a motor, connected to the cam shaft through an enclosed worm gear-speed reducer and flexible coupling. The speed of the cam shaft shall be approximately  $1,666 \text{ s}^{-1}$  (100 rev/min). The motor drive mechanism shall not be fastened or mounted on the table base plate or frame.

The performance of a flow table shall be considered satisfactory if, in calibration tests, the table gives a flow value that does not differ by more than five percentage points from flow values obtained with a suitable calibration material.

### A.3 Design requirements for the flow-table mounting

The flow-table frame shall be tightly bolted to a cast iron or steel plate at least 25 mm thick and 250 mm square. The top surface of this plate shall be machined to a smooth plane surface. The plate shall be anchored to the top of a concrete pedestal by four 13 mm bolts that pass through the plate and are embedded at least 150 mm in the pedestal. The pedestal shall be cast inverted on the base plate. A positive contact between the base plate and the pedestal shall be maintained at all points. No nuts or other such levelling devices shall be used between the plate and the pedestal. Levelling shall be effected by suitable means under the base of the pedestal.

The pedestal shall be 250 mm to 275 mm square at the top and 375 mm to 400 mm square at the bottom, 625 mm to 750 mm in height, and shall be of monolithic construction, cast from concrete weighing at least 2 240 kg/m<sup>3</sup>. A stable gasket cork pad, 13 mm thick and approximately 102 mm square, shall be inserted under each corner of the pedestal. The flow table shall be checked frequently for levelness of the table top, stability of the pedestal, and tightness of the bolts and nuts in the table base and the pedestal plate. A torque of 27 N·m is recommended when tightening those fastenings.

The table top, after the frame has been mounted on the pedestal, shall be level along two diameters at right angles to each other, in both the raised and lowered positions.

### A.4 Flow-table lubrication

The vertical shaft of the table shall be kept clean and shall be lightly lubricated with a light oil (for example, SAE-10). Oil shall not be present between the contact faces of the table top and the supporting frame. Oil on the cam face will lessen wear and promote smoothness of operation. The table should be raised and permitted to drop a dozen or more times just prior to use, if it has not been operated for some time.

### A.5 Design requirements for the mould

The mould for casting the flow specimen shall be of cast bronze or brass, constructed as shown in Figure A.1. The Rockwell hardness number of the metal shall be not less than HRB 25. The diameter of the top opening shall be 69,8 mm ± 0,5 mm for new moulds and 7 mm  $\left( \begin{smallmatrix} +1,3 \\ -0,05 \end{smallmatrix} \right)$  mm for moulds in use. The surfaces of the base and top shall be parallel and at right angles to the vertical axis of the cone. The mould shall have a minimum wall thickness of 5 mm. The outside of the top edge of the mould shall be shaped to provide an integral collar for convenient lifting of the mould. All surfaces shall be machined to a smooth finish. A circular shield approximately 254 mm in diameter, with a centre-opening approximately 102 mm in diameter, made of non-absorbing material not attacked by the test material, shall be used with the flow mould to prevent mortar from spilling onto the table top.

### A.6 Design requirements for the spring-loaded tamper

Figure A.2 shows a suitable spring-loaded tamper design. Any spring-loaded tamper shall allow a controlled pressure to be applied via a 30 mm diameter tamper head.

Dimensions in millimetres

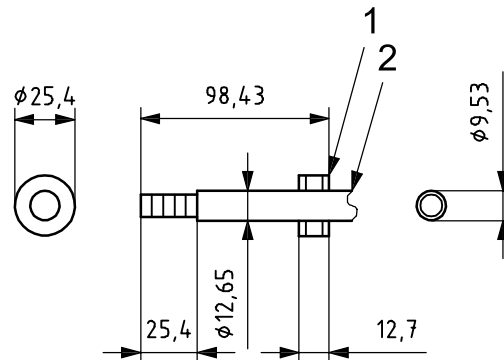
**Key**

- 1 set screw
- 2 to flexible shaft

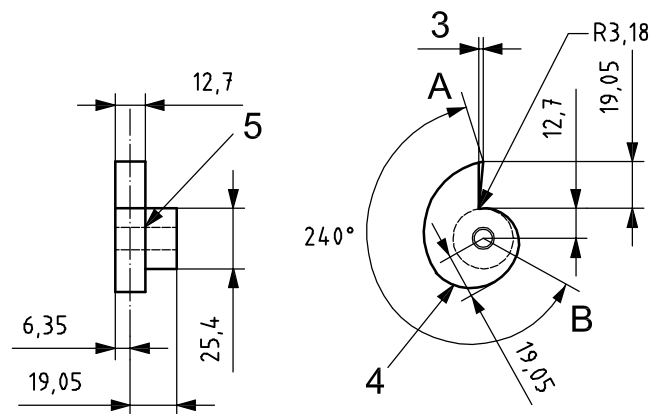
**a) Cam shaft in medium-carbon tool steel****Key**

- 3 undercut 1,59
- 4 working face of cam
- 5 9,53 tap

NOTE The curve from "B" to "A" is a smooth spiral of uniformly increasing radius from 12,7 mm to 31,75 mm in 360°.

**b) Cam in medium-carbon tool steel****Figure A.1 (continued)**

Dimensions in millimetres

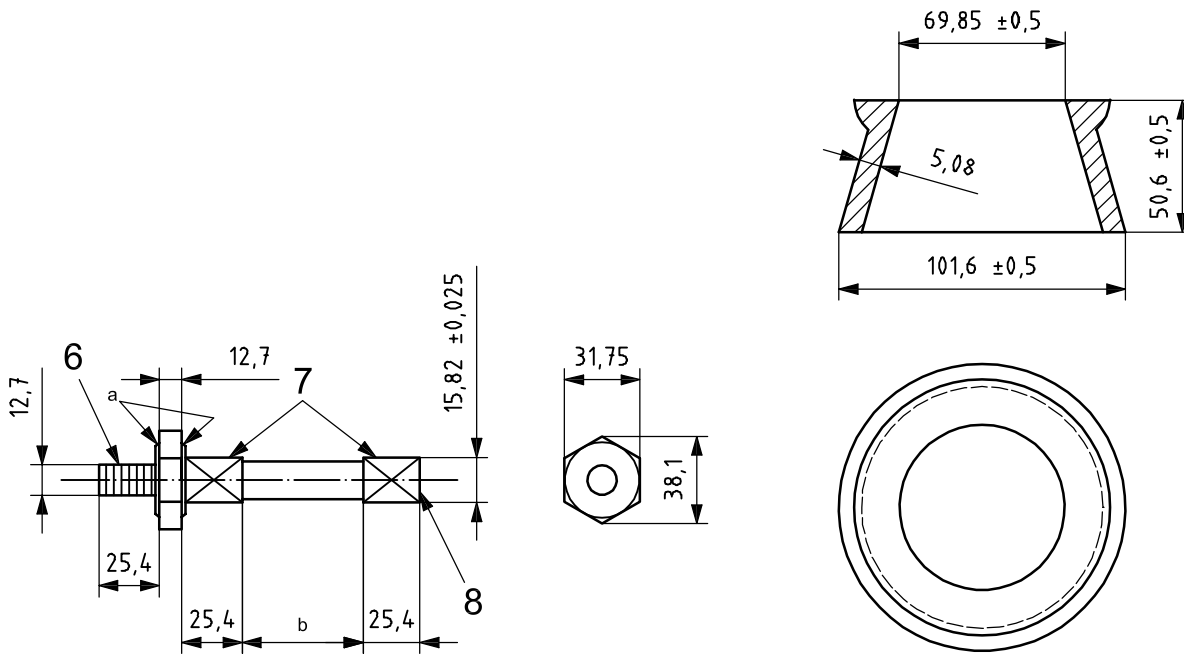

**Key**

- 6 thread 0,5 – 20, UNF-2A
- 7 bearings
- 8 hardened end surface
- a Machine and lap square with shaft to give a 360° contact.
- b Approximately 28,58 adjusted to give a drop of  $12,7 \pm 0,127$ .

**c) Shaft in medium-carbon tool steel**

**d) Mould in bronze at Rockwell HRB 25**

**Figure A.1 (continued)**

Dimensions in millimetres

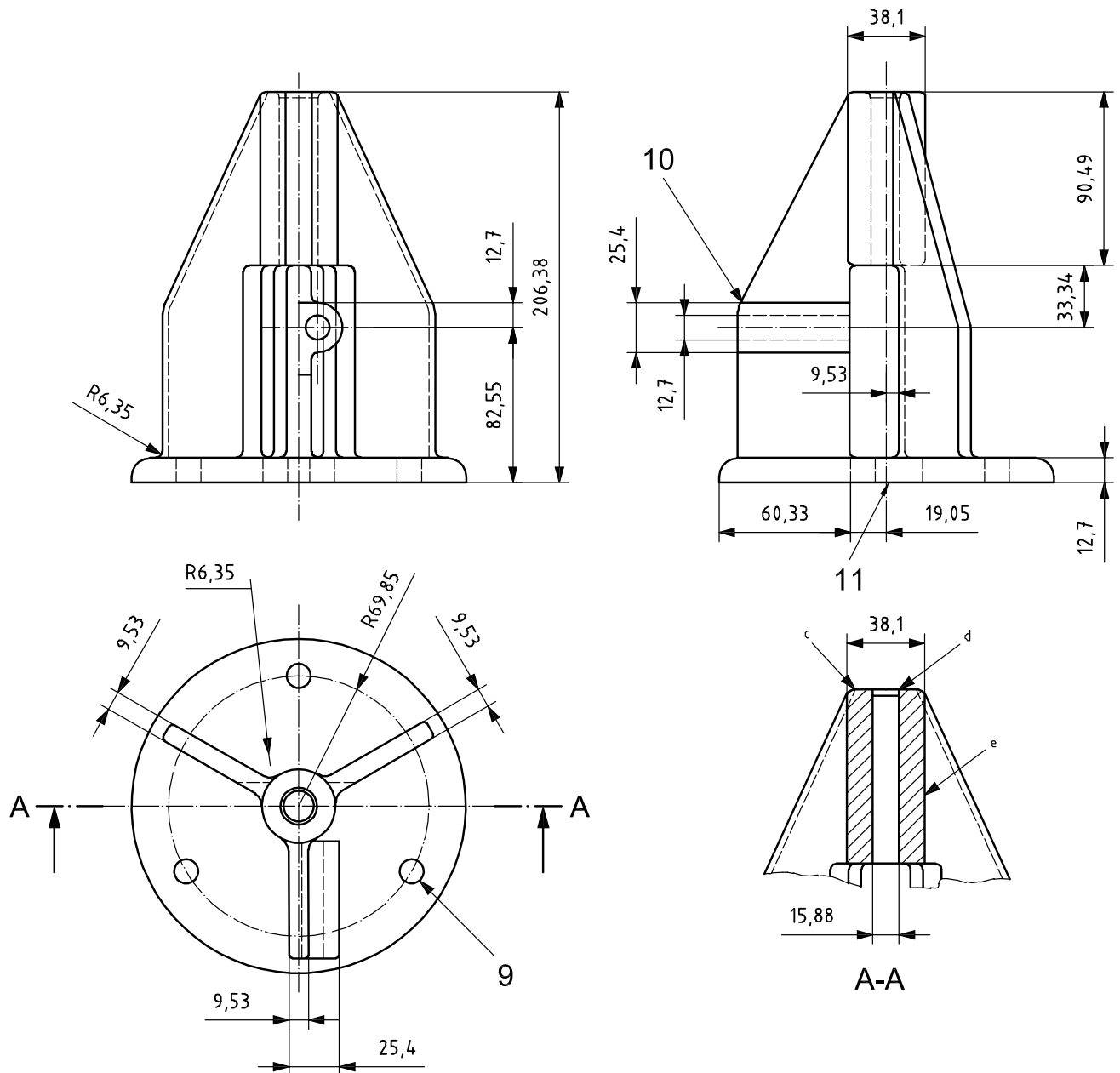
**Key**

- 9 11,11 holes
- 10 spot face
- 11 8,1 hole in base

c Chill to a depth of approximately 6,35 g; grind and lap face square with bore to give a 360° contact with shaft shoulder.

d Bevel to a depth of 1,5 at 45°.

e Bore and ream.

e) Stand in fine-grain, high-grade cast iron

Figure A.1 (continued)

Dimensions in millimetres

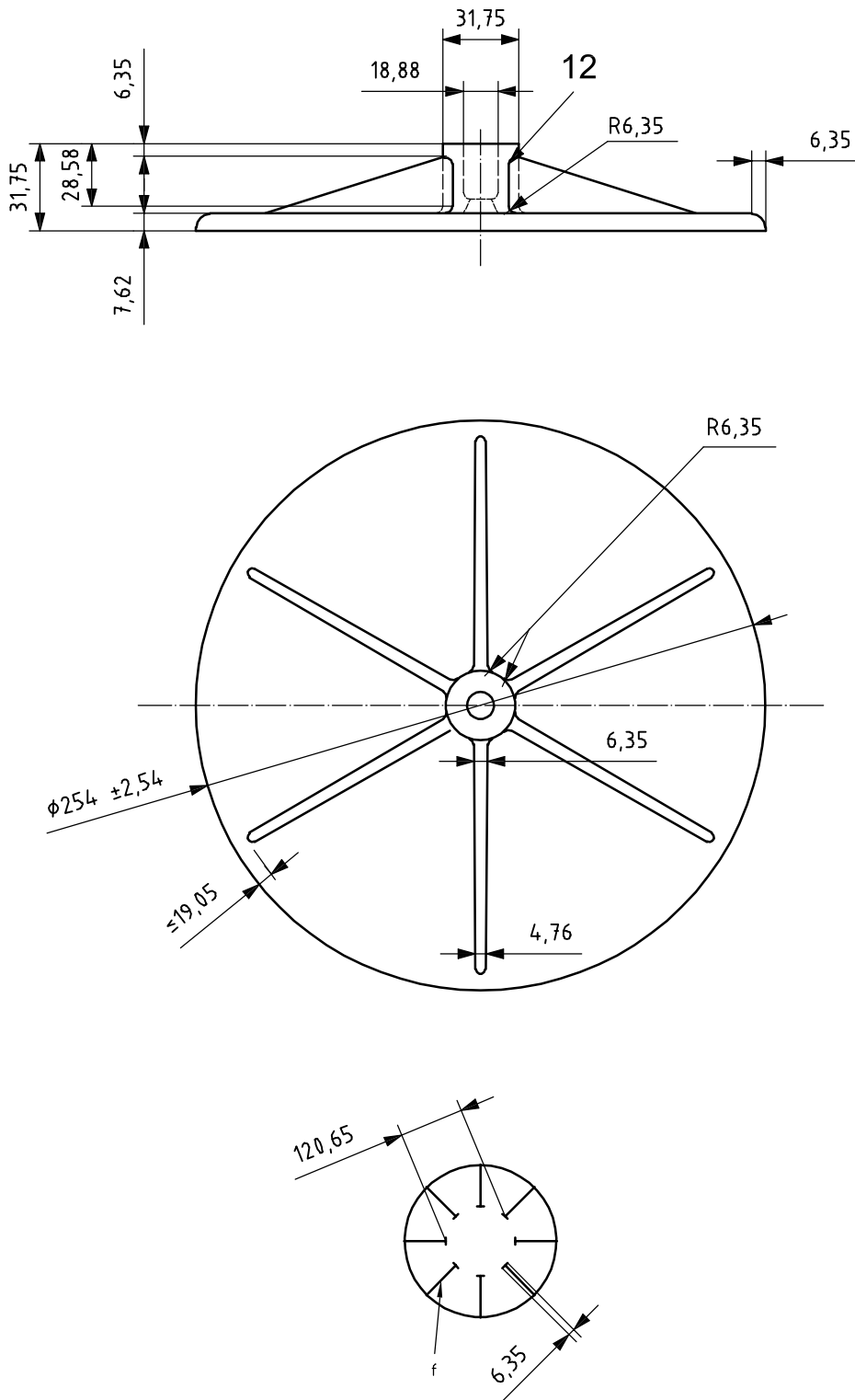

12 thread 0,5 - 20, UNF-2B

f Scribe lines on surface of table with 60° tool to a depth of 0,25.

f) Table in bronze at Rockwell HRB 25 min

Figure A.1 — Flow table and mould apparatus engineering drawings



Dimensions in millimetres

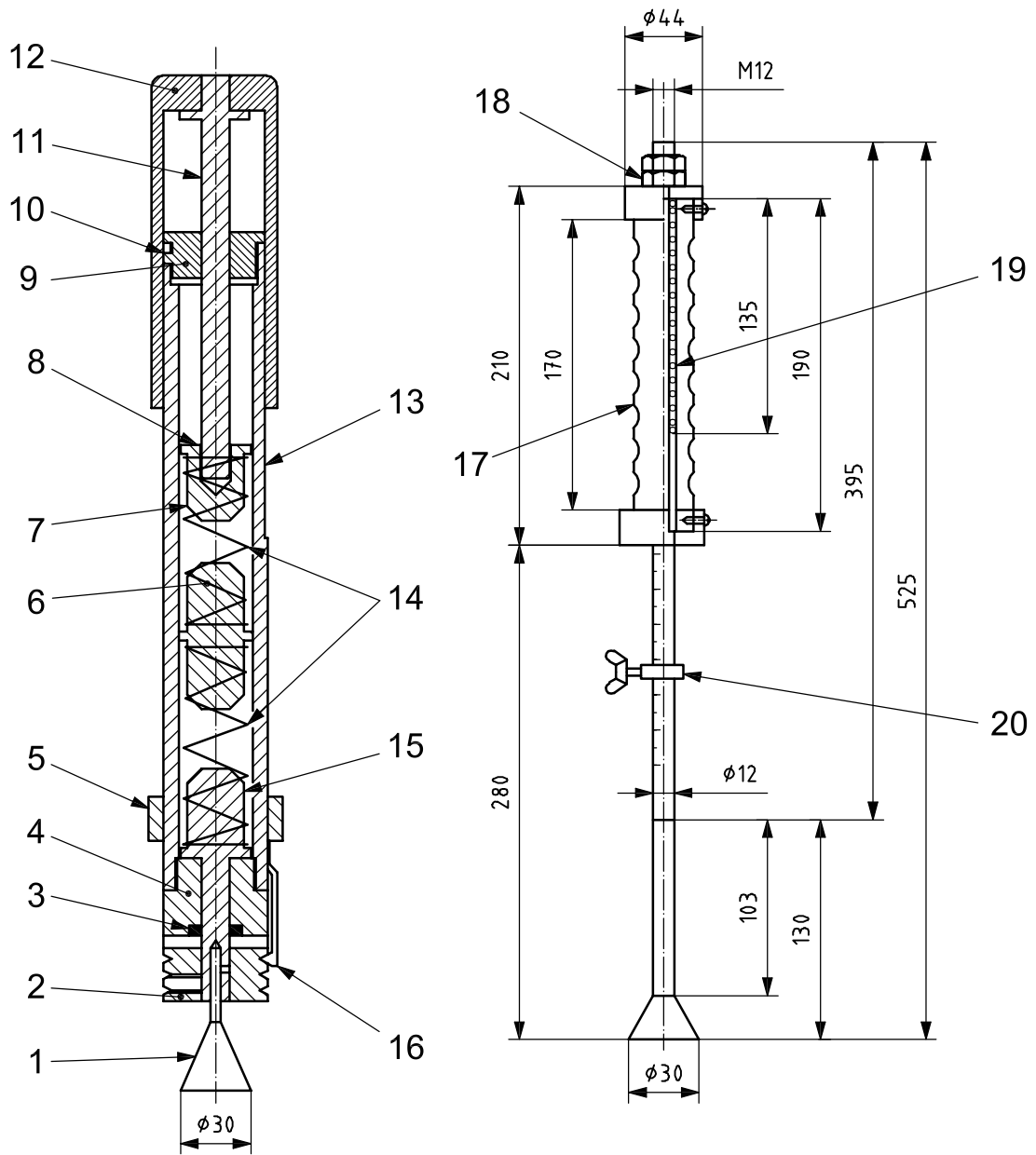

**Key**

- |                     |                                       |                      |                                   |
|---------------------|---------------------------------------|----------------------|-----------------------------------|
| 1 tamper            | 6 spring guide                        | 11 spring compressor | 16 indicator                      |
| 2 indicating collar | 7 screw guide                         | 12 micrometer nut    | 17 wooden handle                  |
| 3 lip seal          | 8 silver solder or grub-screw locking | 13 barrel            | 18 adjusting bolts and nuts       |
| 4 seal plug         | 9 end plug                            | 14 springs           | 19 coll spring                    |
| 5 ring              | 10 M3                                 | 15 bearing shaft     | 20 adjustor for compression valve |

**Figure A.2 — Spring-loaded tamper engineering drawings**

## Bibliography

- [1] International Maritime Organisation (IMO), *Code of Safe Practice for Solid Bulk Cargoes*, 2004
- [2] ASTM C 230-98, *Standard Specification for Flow Table for Use in Tests of Hydraulic Cement*



---

---

# BSI — British Standards Institution

BSI is the independent national body responsible for preparing British Standards. It presents the UK view on standards in Europe and at the international level. It is incorporated by Royal Charter.

## Revisions

British Standards are updated by amendment or revision. Users of British Standards should make sure that they possess the latest amendments or editions.

It is the constant aim of BSI to improve the quality of our products and services. We would be grateful if anyone finding an inaccuracy or ambiguity while using this British Standard would inform the Secretary of the technical committee responsible, the identity of which can be found on the inside front cover.  
Tel: +44 (0)20 8996 9000. Fax: +44 (0)20 8996 7400.

BSI offers members an individual updating service called PLUS which ensures that subscribers automatically receive the latest editions of standards.

## Buying standards

Orders for all BSI, international and foreign standards publications should be addressed to Customer Services. Tel: +44 (0)20 8996 9001.  
Fax: +44 (0)20 8996 7001. Email: [orders@bsi-global.com](mailto:orders@bsi-global.com). Standards are also available from the BSI website at <http://www.bsi-global.com>.

In response to orders for international standards, it is BSI policy to supply the BSI implementation of those that have been published as British Standards, unless otherwise requested.

## Information on standards

BSI provides a wide range of information on national, European and international standards through its Library and its Technical Help to Exporters Service. Various BSI electronic information services are also available which give details on all its products and services. Contact the Information Centre.  
Tel: +44 (0)20 8996 7111. Fax: +44 (0)20 8996 7048. Email: [info@bsi-global.com](mailto:info@bsi-global.com).

Subscribing members of BSI are kept up to date with standards developments and receive substantial discounts on the purchase price of standards. For details of these and other benefits contact Membership Administration.  
Tel: +44 (0)20 8996 7002. Fax: +44 (0)20 8996 7001.  
Email: [membership@bsi-global.com](mailto:membership@bsi-global.com).

Information regarding online access to British Standards via British Standards Online can be found at <http://www.bsi-global.com/bsonline>.

Further information about BSI is available on the BSI website at <http://www.bsi-global.com>.

## Copyright

Copyright subsists in all BSI publications. BSI also holds the copyright, in the UK, of the publications of the international standardization bodies. Except as permitted under the Copyright, Designs and Patents Act 1988 no extract may be reproduced, stored in a retrieval system or transmitted in any form or by any means – electronic, photocopying, recording or otherwise – without prior written permission from BSI.

This does not preclude the free use, in the course of implementing the standard, of necessary details such as symbols, and size, type or grade designations. If these details are to be used for any other purpose than implementation then the prior written permission of BSI must be obtained.

Details and advice can be obtained from the Copyright & Licensing Manager.  
Tel: +44 (0)20 8996 7070. Fax: +44 (0)20 8996 7553.  
Email: [copyright@bsi-global.com](mailto:copyright@bsi-global.com).