

BS ISO 12643-5:2010



BSI Standards Publication

Graphic technology — Safety requirements for graphic technology equipment and systems

Part 5: Stand-alone platen presses

bsi.

...making excellence a habit.™

National foreword

This British Standard is the UK implementation of ISO 12643-5:2010.

The UK participation in its preparation was entrusted to Technical Committee PAI/43, Graphic technology.

A list of organizations represented on this committee can be obtained on request to its secretary.

This publication does not purport to include all the necessary provisions of a contract. Users are responsible for its correct application.

© BSI 2011

ISBN 978 0 580 67873 8

ICS 37.100.10

Compliance with a British Standard cannot confer immunity from legal obligations.

This British Standard was published under the authority of the Standards Policy and Strategy Committee on 28 February 2011.

Amendments issued since publication

Date	Text affected
------	---------------

**Graphic technology — Safety
requirements for graphic technology
equipment and systems —**

**Part 5:
Stand-alone platen presses**

*Technologie graphique — Exigences de sécurité pour les systèmes
et l'équipement de technologie graphique —*

Partie 5: Presses à plateaux autonomes



PDF disclaimer

This PDF file may contain embedded typefaces. In accordance with Adobe's licensing policy, this file may be printed or viewed but shall not be edited unless the typefaces which are embedded are licensed to and installed on the computer performing the editing. In downloading this file, parties accept therein the responsibility of not infringing Adobe's licensing policy. The ISO Central Secretariat accepts no liability in this area.

Adobe is a trademark of Adobe Systems Incorporated.

Details of the software products used to create this PDF file can be found in the General Info relative to the file; the PDF-creation parameters were optimized for printing. Every care has been taken to ensure that the file is suitable for use by ISO member bodies. In the unlikely event that a problem relating to it is found, please inform the Central Secretariat at the address given below.



COPYRIGHT PROTECTED DOCUMENT

© ISO 2010

All rights reserved. Unless otherwise specified, no part of this publication may be reproduced or utilized in any form or by any means, electronic or mechanical, including photocopying and microfilm, without permission in writing from either ISO at the address below or ISO's member body in the country of the requester.

ISO copyright office
Case postale 56 • CH-1211 Geneva 20
Tel. + 41 22 749 01 11
Fax + 41 22 749 09 47
E-mail copyright@iso.org
Web www.iso.org

Published in Switzerland

Contents

Page

Foreword	iv
Introduction.....	v
1 Scope	1
2 Normative references	1
3 Terms and definitions	2
4 Safeguarding of significant hazards	2
4.1 General	2
4.2 Additional safeguarding requirements	2
4.3 Safeguarding side access	3
4.4 Additional requirements for manually fed platen presses	4
4.5 Laser scanners	7
4.6 Platen presses with automatic (timer-controlled) operation	7
4.7 Stopping distance	7
4.8 Main drive braking and clutch/brake mechanism	7
4.9 Gripper chain	7
4.10 Flywheels	7
5 Controls	8
5.1 Pushbuttons.....	8
5.2 Other controls.....	8
6 Automatic stop	8
7 Signals and warning devices	8
7.1 Indicator light for automatic mode	8
7.2 Optional personnel warning light system with audible alarm	8
8 Contents of instructions handbook.....	9
Bibliography.....	10

Foreword

ISO (the International Organization for Standardization) is a worldwide federation of national standards bodies (ISO member bodies). The work of preparing International Standards is normally carried out through ISO technical committees. Each member body interested in a subject for which a technical committee has been established has the right to be represented on that committee. International organizations, governmental and non-governmental, in liaison with ISO, also take part in the work. ISO collaborates closely with the International Electrotechnical Commission (IEC) on all matters of electrotechnical standardization.

International Standards are drafted in accordance with the rules given in the ISO/IEC Directives, Part 2.

The main task of technical committees is to prepare International Standards. Draft International Standards adopted by the technical committees are circulated to the member bodies for voting. Publication as an International Standard requires approval by at least 75 % of the member bodies casting a vote.

Attention is drawn to the possibility that some of the elements of this document may be the subject of patent rights. ISO shall not be held responsible for identifying any or all such patent rights.

ISO 12643-5 was prepared by Technical Committee ISO/TC 130, *Graphic technology*.

It is the intent of ISO/TC 130 that this first edition of ISO 12643-5 become applicable to new equipment manufactured from 2012-01-01.

ISO 12643 consists of the following parts, under the general title *Graphic technology — Safety requirements for graphic technology equipment and systems*:

- *Part 1: General requirements*
- *Part 2: Prepress and press equipment and systems*
- *Part 3: Binding and finishing equipment and systems*
- *Part 4: Converting equipment and systems*
- *Part 5: Stand-alone platen presses*

Introduction

The purpose of this part of ISO 12643 is to reduce the risk of injury to operating personnel working on stand-alone platen presses.

This part of ISO 12643 provides requirements for controls and for guarding residual hazards and hazards created by point of operation of manually fed and automatically fed platen presses. It also provides requirements specific to the use of a flywheel, and specifies safe operating practices and training requirements.

During the development of this part of ISO 12643, existing relevant standards of other countries were taken into consideration. An effort has been made to harmonize the requirements of many countries, recognizing that national standards or laws may dictate national requirements. In cases where it was known that there is a national requirement that differs from this part of ISO 12643, that has been noted.

This part of ISO 12643 was developed to harmonize the following US and European safety standards:

- ANSI B65.5, *Safety standard — Stand-alone platen presses*
- EN 1010-5, *Safety of machinery — Safety requirements for the design and construction of printing and paper converting machines — Part 5: Machines for the production of corrugated board and machines for the conversion of flat and corrugated board*

Graphic technology — Safety requirements for graphic technology equipment and systems —

Part 5: Stand-alone platen presses

1 Scope

This part of ISO 12643 provides safety requirements specific to stand-alone platen presses. It is intended to be used in conjunction with the general requirements given in ISO 12643-1.

This part of ISO 12643 provides additional press design safety requirements for the design and construction of new manually fed or automatic stand-alone platen press systems intended for die-cutting, creasing, embossing, foil stamping and/or the printing of paper, board and other materials processed in a similar manner.

This part of ISO 12643 is not applicable to presses designed to handle metal material other than foil.

2 Normative references

The following referenced documents are indispensable for the application of this document. For dated references, only the edition cited applies. For undated references, the latest edition of the referenced document (including any amendments) applies.

ISO 4414, *Pneumatic fluid power — General rules and safety requirements for systems and their components*

ISO 12643-1, *Graphic technology — Safety requirements for graphic technology equipment and systems — Part 1: General requirements*

ISO 13849-1, *Safety of machinery — Safety-related parts of control systems — Part 1: General principles for design*

ISO 13856-2, *Safety of machinery — Pressure-sensitive protective devices — Part 2: General principles for the design and testing of pressure-sensitive edges and pressure-sensitive bars*

ISO 14120, *Safety of machinery — Guards — General requirements for the design and construction of fixed and movable guards*

IEC 61496-1, *Safety of machinery — Electro-sensitive protective equipment — Part 1: General requirements and tests*

IEC 61496-3, *Safety of machinery — Electro-sensitive protective equipment — Part 3: Particular requirements for Active Opto-electronic Protective Devices responsive to Diffuse Reflection (AOPDDR)*

IEC 62061, *Safety of machinery — Functional safety of safety-related electrical, electronic and programmable electronic control systems*

3 Terms and definitions

For the purposes of this document, the terms and definitions given in ISO 12643-1 and the following apply.

3.1 point of operation

area of the press in which the process (such as die-cutting, embossing, foil stamping, printing, etc.) is being performed

3.2 protective device

safeguard other than a guard

EXAMPLE Examples include, but are not limited to, hold-to-run controls, two-hand controls, ESPDs, etc.

NOTE Adapted from ISO 12100.

3.3 stand-alone platen press

self-contained machine not intended to be used as part of an integrated manufacturing system

3.4 trip bar

protective bar that, when pushed, activates the interlocking safety system of the machine

NOTE A trip bar can be a metal bar or a pressure-sensitive edge.

4 Safeguarding of significant hazards

4.1 General

Safeguarding shall be provided in those areas where it is recognized that operators are exposed to significant hazards. The guarding requirements of ISO 12643-1 apply. Guard construction shall meet the requirements of ISO 14120. All platen presses shall have trip bars (see 4.4) or other protective devices (see 4.5) located where access to a hazard is possible.

4.2 Additional safeguarding requirements

On machines wider than 1,6 m, the impact hazard created by the movable platen while opening shall be guarded by the use of a knee bar (see Figure 1, Item 7). The length of the knee bar shall be equal to or greater than the width of the movable platen. The knee bar shall be constructed such that it will retain its shape to ensure actuation of the trip function throughout its length. With the movable platen in the open position, the clearance between the knee bar and front surface of the movable platen shall be at least 120 mm. See Figure 1.

All trip bars shall be provided with a switch mounted on each end of the trip bar. The signals of the switches allocated to the individual trip device shall be processed separately. The conductor cables connecting the switches shall be physically separated and shall be located outside the electrical cabinet.

Trip functions using mechanical devices (including knee bars) shall satisfy the requirements of ISO 13856-2 and PL_re of ISO 13849-1 or SIL3 of IEC 62061. Trip functions or presence-sensing functions using laser scanners shall satisfy the requirements of PL_rd of ISO 13849-1 or SIL2 of IEC 62061.

The safety system that controls trip devices and their related signal processing, which safeguard routine and regular access to a hazard point on a manually fed device, shall comply with PL_re of ISO 13849-1 or SIL3 of IEC 62061.

4.3 Safeguarding side access

Various means may be used to prevent access from the sides of the press. These means include, but are not limited to, the following measures.

- a) Fixed protective barriers, interlocking guards and/or interlocking tables that prevent access, from any side of the press, to areas of significant hazard not otherwise guarded in accordance with this part of ISO 12643.

If interlocking tables are used, tables shall extend 1 000 mm from the side frame outward and over the length of the press, reaching from the front edge of the open position of the movable platen to at least 250 mm behind the backward edge of the trip device. See Figure 1.

- b) Laser scanners meeting the requirements of 4.5, provided on both sides of the platen, with the scanned area being at a distance of 200 mm minimum and 250 mm maximum (measured from the beginning of the scanned area).

The size and shape of the scanned areas on the sides shall be as shown in Figure 2 a).

Access from the front and rear of the platen press to hazards between the laser scanners and the machine housing shall be prevented by fixed guards [see Figure 2 b)].

Means of preventing access to the hazard zone between the movable platen and the punching plane, other than those defined in a) or b) above, shall provide an equivalent level of protection.

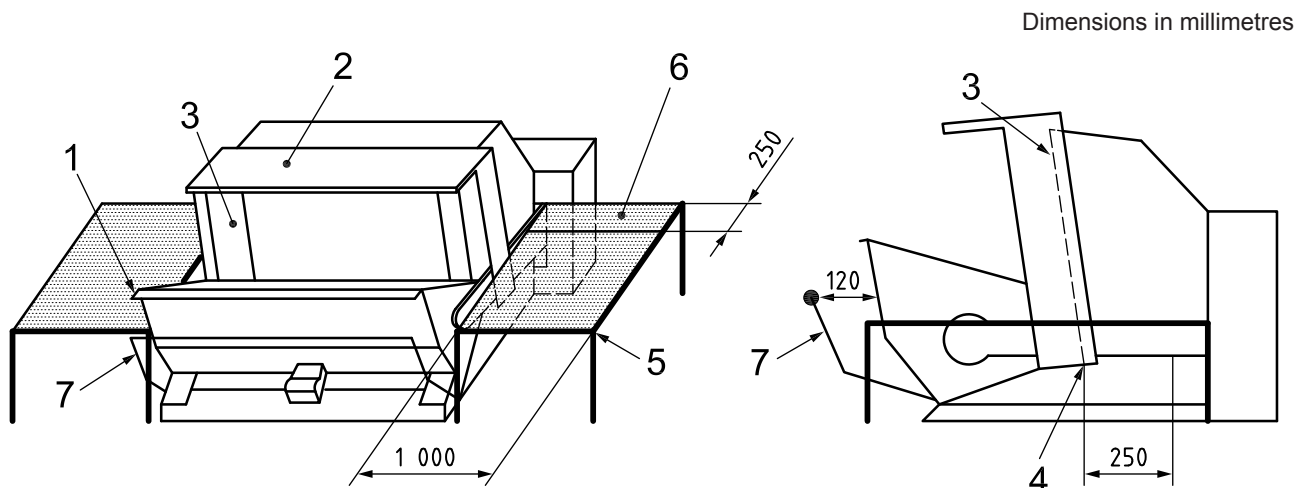

Key

- 1 trip bar on movable platen
- 2 U-shaped trip bar on fixed platen
- 3 punching plane
- 4 backward edge of punching plane
- 5 front edge of interlocking table
- 6 interlocking table
- 7 knee bar

Figure 1 — Interlocking tables

Dimensions in millimetres

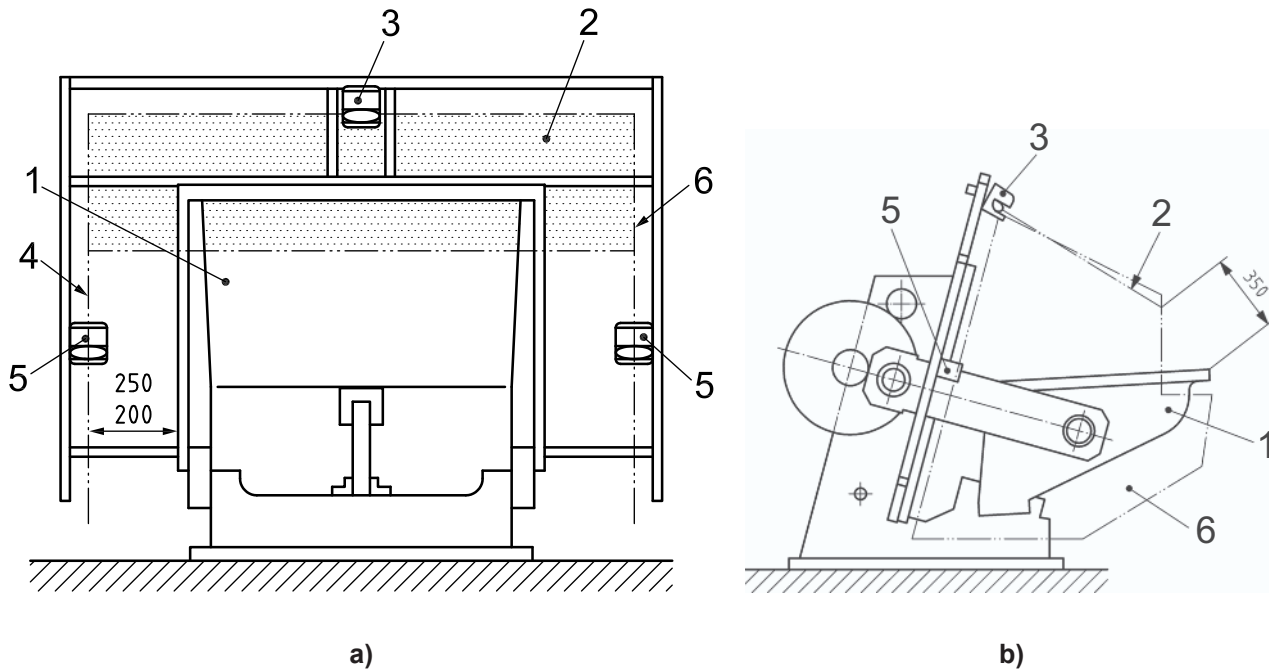

Key

- 1 movable platen
- 2 scanned area on the top
- 3 scanner for the scanned areas on the top
- 4 fixed guard
- 5 scanner for the scanned areas on the sides
- 6 scanned areas on the sides

Figure 2 — Platen press equipped with laser scanner

4.4 Additional requirements for manually fed platen presses

For manually fed machines, one of the following configurations shall be provided.

- a) When the press is less than 1 m wide, an interlocked protective device (U-shaped trip bar) that covers both the sides and the top of the point of operation shall be provided (see Figure 1 and Figure 3). The platen trip bar shall pass under the U-shaped trip bar in its operating position with a maximum clearance of 12 mm (see Figure 4). The minimum distance shall be maintained throughout the range of all operating temperatures.

If the stopping distance specified by the manufacturer is exceeded, the control system shall prevent an additional cycle until the brake/clutch system is adjusted. This requirement shall be met at all speeds of the machine. The stopping distance shall be monitored at the end of each cycle.

NOTE A cycle begins in the stopped position and is completed when the platen returns to the stopped position.

The U-shaped trip bar pivot shall be rated such that a force of 20 N is sufficient for actuation and triggering of the clutch/brake device. The pivot of the U-shaped trip bar shall be below the punching plane (see Figure 5).

For manually fed machines operated in the automatic (timer-controlled) mode, an additional trip bar, usually located on the top edge of the movable platen, shall also be provided. This trip bar, when actuated, shall stop platen motion.

- b) For machines greater than 1 m wide, a presence-sensing device that will detect the presence of a person on the moveable platen. If a person is detected, start-up shall be prevented.
- c) A laser scanner mounted on the top of the fixed platen (see Figure 2) and meeting the requirements of 4.5. The gap between the scanned area and the movable platen in maximum open position shall be not greater than 350 mm.
- d) Three laser scanners, one on each side and one on the top, shall be used to detect entry from the top and sides and shall be integrated with the safety system of the machine. The laser scanners shall meet the requirements of 4.5.

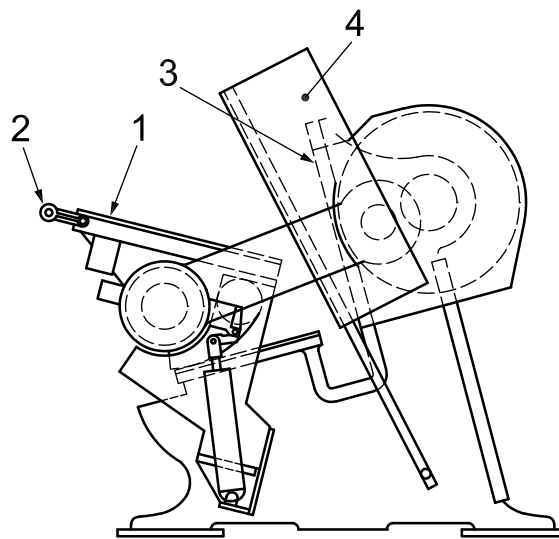

Key

- 1 platen
- 2 platen trip bar
- 3 die mounting surface
- 4 protective device

Figure 3 — Safety protection for point of operation (press open)

Dimensions in millimetres

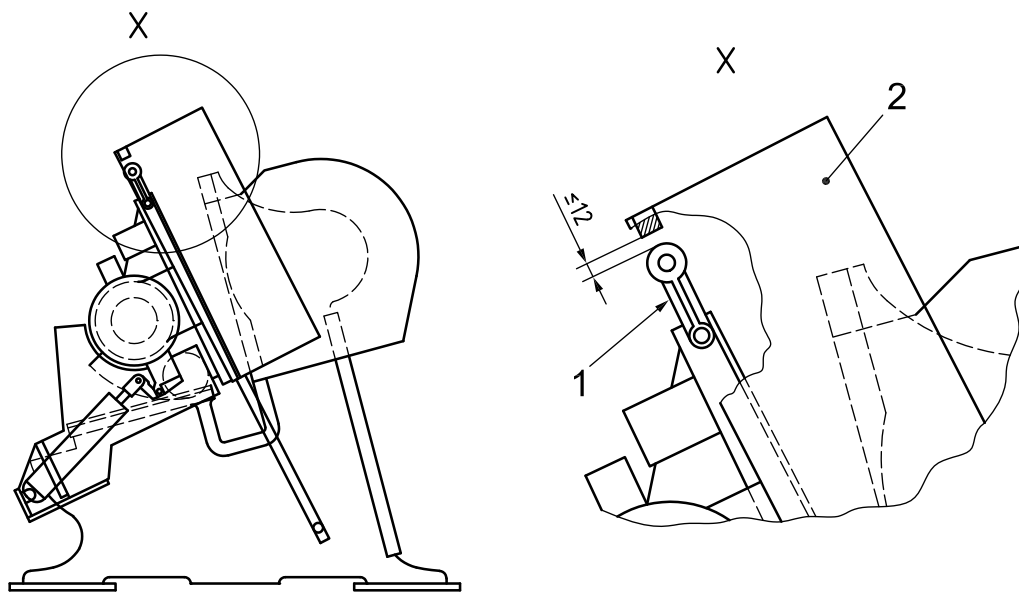

Key

- 1 platen trip bar
- 2 protective device in operating position

Figure 4 — Relationship between safety device and platen trip bar

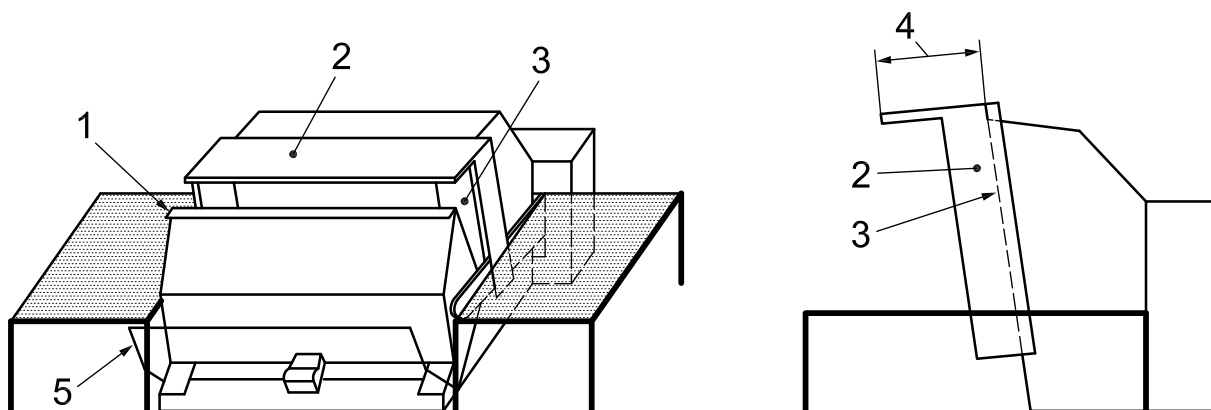

Key

- 1 trip bar on movable platen
- 2 U-shaped trip bar on fixed platen
- 3 punching plane
- 4 horizontal part of trip bar
- 5 knee bar

Figure 5 — Trip bars

4.5 Laser scanners

Laser scanners shall meet the requirements of IEC 61496-1 and IEC 61496-3.

When the press is in motion and the presence of a person is detected by a laser scanner, the machine shall stop with a stopping distance, measured at the top of the platen, not greater than 120 mm. Further movement of the platen shall require a reset and shall not automatically restart.

When the platen press is stopped (at rest) and the presence of a person is detected by a laser scanner, unexpected start-up shall be prevented and the press shall not start automatically.

4.6 Platen presses with automatic (timer-controlled) operation

On platen presses with timer-controlled operation, the open dwell time shall not exceed 10 s. When the platen press is in automatic mode, the warning requirements of 7.1 shall be met.

4.7 Stopping distance

The stopping distance of the platen press shall not exceed 120 mm. This shall be measured between the top edges of the moveable and fixed platens.

On manually fed platen presses, if the stopping time or stopping distance specified by the manufacturer is exceeded, start-up shall be prevented. The stopping distance shall be monitored at the end of each cycle.

4.8 Main drive braking and clutch/brake mechanism

All platen presses shall be equipped with either a fail-safe brake or a fail-safe clutch/brake mechanism which shall stop and prevent press motion when engaged. Hand-fed platen presses shall be equipped with a fail-safe clutch/brake mechanism to disconnect the stored energy in the flywheel from the moving platen and bring the platen to a stop.

On presses with flywheels, this mechanism shall be located on the flywheel shaft.

When using a clutch/brake mechanism, electric power supply failure, or loss of pneumatic or hydraulic pressure, shall activate the brake and disengage the clutch (i.e. fail-safe). The brake shall be of sufficient strength to maintain the platen in the position in which it stopped due to the failure.

If a pneumatic system is used for the combined clutch and brake system (stopping closing movement of the platen), two pneumatic valves shall be provided. The pneumatic system shall meet the requirements of PL_r of ISO 13849-1. The pneumatic system shall comply with the requirements of ISO 4414.

4.9 Gripper chain

When a guard is open, unexpected movement of the gripper chain on automatically fed machines shall be prevented by the use of a mechanical means other than the main press brake.

NOTE An example of this is the use of a gripper chain lock to prevent movement of the gripper chain due to a mechanical failure within the drive system.

4.10 Flywheels

Flywheels shall be enclosed or otherwise guarded in accordance with ISO 12643-1. A flywheel retention device shall be provided to ensure that the flywheel will not come off its shaft unexpectedly.

NOTE A key in a keyway is not considered to be a flywheel retention device.

5 Controls

5.1 Pushbuttons

5.1.1 General

Pushbuttons shall meet the requirements of ISO 12643-1 and 5.1.2.

5.1.2 Emergency stop

On manually fed platen presses, an emergency stop pushbutton shall be provided on the motion control station. The emergency stop control shall meet the requirements of ISO 12643-1.

5.2 Other controls

5.2.1 Control to permit manual movement of machine

A control shall be provided to release the brake and engage the clutch, if necessary, to permit manual movement of the press. This control shall only function when the motion of the main drive motor is inhibited.

5.2.2 Selector switches

Multiple-position selector switches may be used in conjunction with another motion control and shall not be an alternative or substitute for the pushbutton controls defined in ISO 12643-1.

6 Automatic stop

After an automatically initiated stop, the press shall not start automatically. The operator shall go through the normal starting sequence, which may require a reset in some instances, in order to initiate press motion.

NOTE An automatically initiated stop might be the result of the activation of a guard interlock, jam, detection of an obstruction by a scanner, etc.

7 Signals and warning devices

7.1 Indicator light for automatic mode

A flashing red indicator light shall be provided in the operator's view, clearly indicating when the machine is in automatic (dwell) mode.

7.2 Optional personnel warning light system with audible alarm

7.2.1 General

If a personnel warning light system is used, it shall comply with ISO 12643-1, with the exception of the state of the warning devices. The state of the warning devices shall be as shown in Table 1.

NOTE In countries where the use of personnel warning lights is required, national requirements take precedence over this part of ISO 12643.

Table 1 — State of warning devices for audible warning system with personnel warning lights

Warning device	Stop/safe	Ready	Warning period	Permissive period	Machine motion
Green personnel warning lights	On	Off	Off	Off	Off
Red personnel warning lights	Off	On	Flash	Flash	On
Audible alarm	Off	Off	On	Off	Off

7.2.2 Permissive period

The permissive period shall meet the requirements of ISO 12643-1.

8 Contents of instructions handbook

In addition to the requirements of ISO 12643-1 that are appropriate to platen presses, the instruction handbook shall also contain the following:

- a) statement that the safety devices (e.g. trip bars and laser scanners) and brake shall be checked daily for proper operation;
- b) statement that test results of the daily testing of the safety devices should be recorded in a written report;
- c) procedures for safe routine adjustment, cleaning, inspection and maintenance of equipment, including power isolation procedures.

Bibliography

- [1] ANSI B65.5, *Safety standard — Stand-alone platen presses*
- [2] EN 1010-5, *Safety of machinery — Safety requirements for the design and construction of printing and paper converting machines — Part 5: Machines for the production of corrugated board and machines for the conversion of flat and corrugated board*
- [3] ISO 12100, *Safety of machinery — General principles for design — Risk assessment and risk reduction*
- [4] ISO 13857, *Safety of machinery — Safety distances to prevent hazard zones being reached by upper and lower limbs*
- [5] ISO 14121-1, *Safety of machinery — Risk assessment — Part 1: Principles*

ICS 37.100.10

Price based on 10 pages

British Standards Institution (BSI)

BSI is the national body responsible for preparing British Standards and other standards-related publications, information and services.

BSI is incorporated by Royal Charter. British Standards and other standardization products are published by BSI Standards Limited.

About us

We bring together business, industry, government, consumers, innovators and others to shape their combined experience and expertise into standards-based solutions.

The knowledge embodied in our standards has been carefully assembled in a dependable format and refined through our open consultation process. Organizations of all sizes and across all sectors choose standards to help them achieve their goals.

Information on standards

We can provide you with the knowledge that your organization needs to succeed. Find out more about British Standards by visiting our website at bsigroup.com/standards or contacting our Customer Services team or Knowledge Centre.

Buying standards

You can buy and download PDF versions of BSI publications, including British and adopted European and international standards, through our website at bsigroup.com/shop, where hard copies can also be purchased.

If you need international and foreign standards from other Standards Development Organizations, hard copies can be ordered from our Customer Services team.

Subscriptions

Our range of subscription services are designed to make using standards easier for you. For further information on our subscription products go to bsigroup.com/subscriptions.

With **British Standards Online (BSOL)** you'll have instant access to over 55,000 British and adopted European and international standards from your desktop. It's available 24/7 and is refreshed daily so you'll always be up to date.

You can keep in touch with standards developments and receive substantial discounts on the purchase price of standards, both in single copy and subscription format, by becoming a **BSI Subscribing Member**.

PLUS is an updating service exclusive to BSI Subscribing Members. You will automatically receive the latest hard copy of your standards when they're revised or replaced.

To find out more about becoming a BSI Subscribing Member and the benefits of membership, please visit bsigroup.com/shop.

With a **Multi-User Network Licence (MUNL)** you are able to host standards publications on your intranet. Licences can cover as few or as many users as you wish. With updates supplied as soon as they're available, you can be sure your documentation is current. For further information, email bsmusales@bsigroup.com.

BSI Group Headquarters

389 Chiswick High Road London W4 4AL UK

Revisions

Our British Standards and other publications are updated by amendment or revision.

We continually improve the quality of our products and services to benefit your business. If you find an inaccuracy or ambiguity within a British Standard or other BSI publication please inform the Knowledge Centre.

Copyright

All the data, software and documentation set out in all British Standards and other BSI publications are the property of and copyrighted by BSI, or some person or entity that owns copyright in the information used (such as the international standardization bodies) and has formally licensed such information to BSI for commercial publication and use. Except as permitted under the Copyright, Designs and Patents Act 1988 no extract may be reproduced, stored in a retrieval system or transmitted in any form or by any means – electronic, photocopying, recording or otherwise – without prior written permission from BSI. Details and advice can be obtained from the Copyright & Licensing Department.

Useful Contacts:

Customer Services

Tel: +44 845 086 9001

Email (orders): orders@bsigroup.com

Email (enquiries): cservices@bsigroup.com

Subscriptions

Tel: +44 845 086 9001

Email: subscriptions@bsigroup.com

Knowledge Centre

Tel: +44 20 8996 7004

Email: knowledgecentre@bsigroup.com

Copyright & Licensing

Tel: +44 20 8996 7070

Email: copyright@bsigroup.com



...making excellence a habit.™