

BS ISO 12614-2:2014



BSI Standards Publication

Road vehicles — Liquefied natural gas (LNG) fuel system components

Part 2: Performance and general test methods

bsi.

...making excellence a habit.™

National foreword

This British Standard is the UK implementation of ISO 12614-2:2014.

The UK participation in its preparation was entrusted to Technical Committee GSE/40, Gas supply equipment for natural gas vehicles.

A list of organizations represented on this committee can be obtained on request to its secretary.

This publication does not purport to include all the necessary provisions of a contract. Users are responsible for its correct application.

© The British Standards Institution 2014. Published by BSI Standards Limited 2014

ISBN 978 0 580 77043 2

ICS 43.060.40

Compliance with a British Standard cannot confer immunity from legal obligations.

This British Standard was published under the authority of the Standards Policy and Strategy Committee on 31 July 2014.

Amendments issued since publication

Date	Text affected
------	---------------

**Road vehicles — Liquefied natural gas
(LNG) fuel system components —**

**Part 2:
Performance and general test
methods**

*Véhicules routiers — Équipements pour véhicules utilisant le gaz
naturel liquéfié (GNL) comme combustible —*

Partie 2: Performances et méthodes d'essai générales





COPYRIGHT PROTECTED DOCUMENT

© ISO 2014

All rights reserved. Unless otherwise specified, no part of this publication may be reproduced or utilized otherwise in any form or by any means, electronic or mechanical, including photocopying, or posting on the internet or an intranet, without prior written permission. Permission can be requested from either ISO at the address below or ISO's member body in the country of the requester.

ISO copyright office
Case postale 56 • CH-1211 Geneva 20
Tel. + 41 22 749 01 11
Fax + 41 22 749 09 47
E-mail copyright@iso.org
Web www.iso.org

Published in Switzerland

Contents

Page

Foreword	iv
1 Scope	1
2 Normative references	1
3 Terms and definitions	1
4 General	2
5 Hydrostatic strength	2
6 Leakage	2
7 Excess torque resistance	3
8 Bending moment	3
9 Continued operation	4
9.1 General.....	4
9.2 Components, which are intended to be used at temperatures less than $-40\text{ }^{\circ}\text{C}$	5
9.3 Components, which are not intended to be used at temperatures less than $-40\text{ }^{\circ}\text{C}$	5
10 Corrosion resistance	5
11 Oxygen ageing	5
12 Electrical overvoltages	6
13 Non-metallic material immersion	6
14 Vibration resistance	6
15 Brass material compatibility	6
Bibliography	8

Foreword

ISO (the International Organization for Standardization) is a worldwide federation of national standards bodies (ISO member bodies). The work of preparing International Standards is normally carried out through ISO technical committees. Each member body interested in a subject for which a technical committee has been established has the right to be represented on that committee. International organizations, governmental and non-governmental, in liaison with ISO, also take part in the work. ISO collaborates closely with the International Electrotechnical Commission (IEC) on all matters of electrotechnical standardization.

The procedures used to develop this document and those intended for its further maintenance are described in the ISO/IEC Directives, Part 1. In particular the different approval criteria needed for the different types of ISO documents should be noted. This document was drafted in accordance with the editorial rules of the ISO/IEC Directives, Part 2 (see www.iso.org/directives).

Attention is drawn to the possibility that some of the elements of this document may be the subject of patent rights. ISO shall not be held responsible for identifying any or all such patent rights. Details of any patent rights identified during the development of the document will be in the Introduction and/or on the ISO list of patent declarations received (see www.iso.org/patents).

Any trade name used in this document is information given for the convenience of users and does not constitute an endorsement.

For an explanation on the meaning of ISO specific terms and expressions related to conformity assessment, as well as information about ISO's adherence to the WTO principles in the Technical Barriers to Trade (TBT) see the following URL: Foreword - Supplementary information

The committee responsible for this document is ISO/TC 22, *Road vehicles*, Subcommittee SC 25, *Vehicles using gaseous fuels*.

ISO 12614 consists of the following parts, under the general title *Road vehicles — Liquefied natural gas (LNG) fuel system components*:

- *Part 1: General requirements and definitions*
- *Part 2: Performance and general test methods*
- *Part 3: Check valve*
- *Part 4: Manual valve*
- *Part 5: Tank pressure gauge*
- *Part 6: Pressure regulator*
- *Part 7: Pressure relief valve*
- *Part 8: Excess flow valve*
- *Part 9: Gas-tight housing and ventilation hose*
- *Part 10: Rigid fuel line in stainless steel*
- *Part 11: Fittings*
- *Part 12: Rigid fuel line in copper and its alloys*
- *Part 13: Pressure control regulator*
- *Part 14: Differential pressure fuel content gauge*
- *Part 15: Capacitance fuel content gauge*

- *Part 16: Heat exchanger – vaporizer*
- *Part 17: Natural gas detector*
- *Part 18: Gas temperature sensor*

Road vehicles — Liquefied natural gas (LNG) fuel system components —

Part 2: Performance and general test methods

1 Scope

This part of ISO 12614 specifies general requirements and definitions of liquefied natural gas fuel system components, intended for use on the types of motor vehicles as defined in ISO 3833. This part of ISO 12614 is also applicable to other LNG-fueled motor vehicles (for example ships) as far as appropriate, until any specific norm would be worked out for such a type of vehicle. It also provides general design principles, and specifies requirements for instructions and marking.

This part of ISO 12614 is not applicable to the following:

- a) fuel containers;
- b) stationary gas engines;
- c) container mounting hardware;
- d) electronic fuel management;
- e) refueling receptacles.

NOTE 1 It is recognized that miscellaneous components not specifically covered herein can be examined to meet the criteria of this part of ISO 12614 and tested according to the appropriate functional tests.

NOTE 2 All references to pressure in this part of ISO 12614 are to be considered gauge pressures unless otherwise specified.

NOTE 3 This part of ISO 12614 is based upon a working pressure for natural gas as fuel of 1,6 MPa (16 bar). (1 bar = 0,1 MPa = 105 Pa; 1 MPa = 1 N/mm².) Other working pressures can be accommodated by adjusting the pressure by the appropriate factor (ratio). For example, a 2 MPa (20 bar) working pressure system will require pressures to be multiplied by 1,25.

2 Normative references

The following documents, in whole or in part, are normatively referenced in this document and are indispensable for its application. For dated references, only the edition cited applies. For undated references, the latest edition of the referenced document (including any amendments) applies.

ISO 188:2011, *Rubber, vulcanized or thermoplastic — Accelerated ageing and heat resistance tests*

ISO 12614-1:2014, *Road vehicles — Liquefied natural gas (LNG) fuel system components — Part 1: General requirements and definitions*

ISO 15500-2:2012, *Road vehicles — Compressed natural gas (CNG) fuel system components — Part 2: Performance and general test methods*

3 Terms and definitions

For the purposes of this document, the terms and definitions in ISO 12614-1 apply.

4 General

4.1 Unless stated otherwise, the tests specified herein shall be conducted at room temperature, i.e. $20\text{ °C} \pm 5\text{ °C}$.

4.2 Components shall comply with the tests outlined in ISO 12614-3 and subsequent parts of ISO 12614 and any other applicable tests specified in this part of ISO 12614. Because of the peculiarities of some components, the list of tests described in this part of the ISO 12614 from [Clause 5](#) to [15](#) is not exhaustive. If additional tests are required, their requirements are provided in the respective part of ISO 12614.

4.3 Unless otherwise specified, all tests shall be conducted using dry air or nitrogen. Qualified personnel can also test with natural gas providing that appropriate safety measures are fulfilled. The dewpoint of the test gas at the test pressure shall be at the temperature which ensures no icing, hydrate, or liquid formation. For testing at low temperatures, liquid nitrogen will be used, which will be specifically mentioned at the respective parts of the norm.

4.4 It is recognized that new technology might not be covered in ISO 12614-3 and subsequent parts of ISO 12614.

5 Hydrostatic strength

A component shall not rupture when subjected to the following test method.

Outlet opening of the component shall be plugged. Valves or internal blocks shall be ensured in the open position. The hydrostatic pressure specified for each component in ISO 12614 and subsequent parts shall be applied with a test fluid to the inlet of the component for a period of at least 3 min.

Test samples shall not be used for any other testing.

6 Leakage

Prior to conditioning, the devices shall be purged with nitrogen and then sealed at 30 % of working pressure using nitrogen, dry air, or natural gas.

All tests shall be conducted while the devices are continuously exposed to the specified test temperatures. The device shall either be bubble free or have a leakage rate less than $20\text{ Ncm}^3/\text{h}$ according to the following test method.

External leakage

Each device outlet shall be plugged with the appropriate mating connection and the test pressure applied to the inlet.

Pressurized air, nitrogen, or natural gas shall be applied to the test devices.

At all the test temperatures, immerse the components in a suitable test medium for 2 min or use a helium vacuum test (global accumulation method) or other equivalent methods.

If there are no bubbles for the specified time period, the sample passes the test. If bubbles are detected, then the leak rate shall be measured by an appropriate method.

Internal leakage

The internal leakage is applicable only to devices having a closed position. The aim of this test is to check the pressure tightness of the closed system.

The inlet or outlet of the device (as applicable) shall be connected with the appropriate mating connection while the opposite connection(s) shall be left open.

Test conditions for internal and external leakage

- a) The device shall be conditioned at a low temperature of $<-162\text{ }^{\circ}\text{C}$ and pressurized at 100 % and 25 % of working pressure.
- b) The device shall be conditioned at room temperature of $20\text{ }^{\circ}\text{C}$ and pressurized at 25 % and 150 % of working pressure.
- c) The device shall be conditioned at a high temperature of $85\text{ }^{\circ}\text{C}/120\text{ }^{\circ}\text{C}$ and pressurized at 25 % and 150 % of working pressure.

7 Excess torque resistance

A component designed to be connected directly to threaded fittings shall be capable of withstanding without deformation, breakage, or leakage a torque effort of 150 % of the rated installation value.

The following test method shall apply.

- a) An unused component shall be used for this test. The torque shall be applied adjacent to the fitting.
- b) For a component having threaded connection(s), the turning effort shall be applied for 15 min, then released, and the component removed and examined for deformation and breakage. The component shall then be subjected to the leakage test specified in [Clause 6](#).
- c) Subject the component to the leakage test specified in [Clause 6](#).
- d) Subject the component to the hydrostatic strength test specified in [Clause 5](#)

8 Bending moment

A component subject to bending moment tests shall be capable of operation without cracking, breaking, or leaking when subjected to the following test method.

- a) The connections of the component shall be assembled leak-tight to an appropriate mating connection(s), representative of design intent. After assembly, the length of the inlet tubing shall be greater than 300 mm (see [Figure 1](#)).
- b) The outlet connection shall be rigidly supported 25 mm from the component outlet, unless the following exceptions apply:
 - when the component has an integral mounting means independent of the inlet and outlet connections, the component shall be mounted using the integral mounting means as specified by the manufacturer;
 - when the component is intended to be mounted by either the integral mounting means or the component outlet, the mounting means which produces the most severe test condition shall be used.
- c) This assembly above shall be checked for leaks prior to section d).
- d) With the component in the closed position, the system shall be pressurized to 5 kPa and a force as specified in [Table 1](#) at 300 mm from the inlet shall be applied and maintained for 15 min. Without removing the force, the component shall be checked for leakage, in accordance with the test method in [Clause 6](#) at room temperature.

NOTE Depending on how this is performed, raising the load to compensate buoyancy could be necessary.

- e) The test in section d) shall be conducted four times with the component being rotated 90° around the horizontal axis between each test. Between tests, the components shall be opened and closed (if applicable) three times with the bending moment removed.

- f) At the completion of the above tests, the component shall be removed and examined for deformation and then subjected to the leakage test as specified in [Clause 6](#) and to the hydrostatic strength test according to [Clause 5](#).

Table 1 — Bending test force

Outside diameter of tubing mm	Force N
6	3,4
8	9,0
12	17,0
≥16	30,0

Dimensions in millimetres

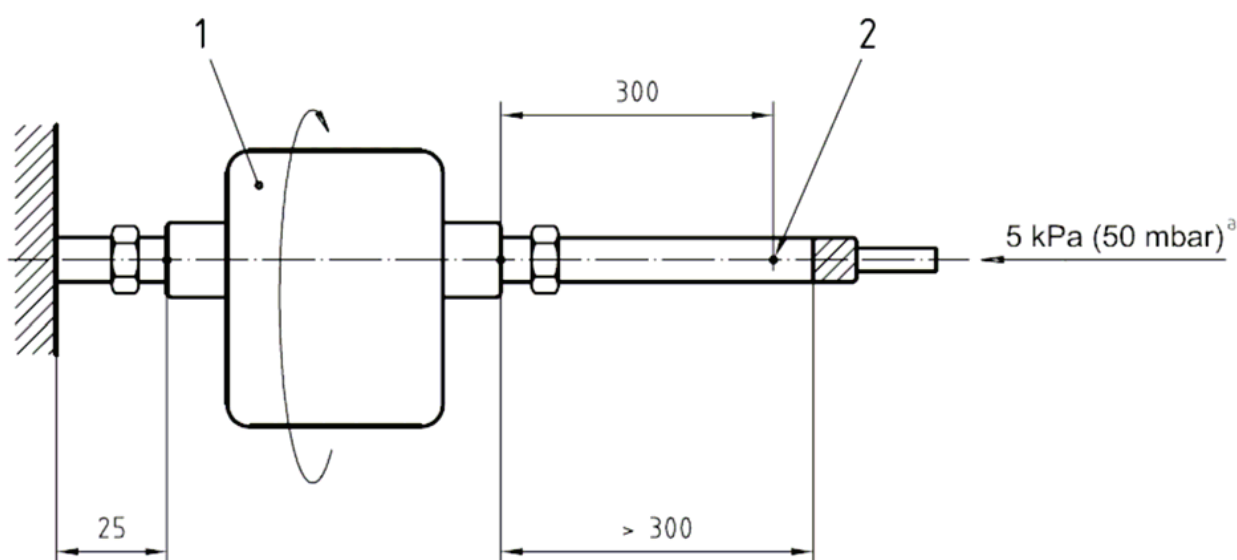

Key

- 1 component
- 2 force point
- a $4 \times 90^\circ$ rotation

Figure 1 — Bending moment

9 Continued operation

9.1 General

Detailed test methods for each component can be found in the appropriate parts of this part of ISO 12614. The test method detailed below is general in nature and also applies to miscellaneous components.

Connect the component securely by a suitable fitting to a source of compressed dry air, nitrogen, or natural gas and subject it to the number of cycles specified in ISO 12614-3 and subsequent parts of ISO 12614. A cycle shall consist of one opening and one closing (if applicable) of the component within a period of not less than $10 \text{ s} \pm 2 \text{ s}$. During the off cycle, the downstream pressure of the test fixture shall be lowered to a maximum of 50 % of the test pressure.

In the case of components downstream of the first stage of pressure reduction, the test pressure shall be based on 100 % of the working pressure.

Unless otherwise specified, the following conditions apply.

9.2 Components, which are intended to be used at temperatures less than $-40\text{ }^{\circ}\text{C}$

The component shall be operated through 96 % of the total cycles at $<-162\text{ }^{\circ}\text{C}$ temperature and working pressure, and shall comply with [Clause 6](#) at low temperature.

The component shall be operated through 4 % of the total cycles at the appropriate maximum temperature specified in ISO 12614-1:2014, 4.4 at working pressure.

The component shall comply with [Clause 6](#) at the appropriate maximum temperature specified in ISO 12614-1:2014, 4.4 at the completion of the low temperature cycles.

This test can be interrupted, if desired, at 20 % intervals for leakage testing.

9.3 Components, which are not intended to be used at temperatures less than $-40\text{ }^{\circ}\text{C}$

The component shall be operated through 2 % of the total cycles at the appropriate maximum temperature specified in ISO 12614-1:2014, 4.4 at working pressure. The component shall comply with [Clause 6](#) at the appropriate maximum temperature specified in ISO 12614-1:2014, 4.4 at the completion of the high temperature cycles.

The component shall be operated through 96 % of the total cycles at room temperature and at working pressure, and shall comply with [Clause 6](#) at room temperature.

See ISO 12614-1:2014, 4.4. for the low temperature value. The component shall be operated through 2 % of the total cycles at the appropriate minimum temperature specified in ISO 12614-1:2014, 4.4 at 50 % of working pressure.

The component shall comply with [Clause 6](#) at the appropriate minimum temperature specified in ISO 12614-1:2014, 4.4 at the completion of the low temperature cycles.

Immediately following the continued operation tests and leakage retesting, perform the hydrostatic test according to [Clause 5](#).

10 Corrosion resistance

All components shall comply with ISO 15500-2:2012, Clause 10.

Immediately following the corrosion test, the sample shall be rinsed and gently cleaned of salt deposits then subjected to [Clause 6](#).

Immediately following the leakage test, subject the test sample to the hydrostatic strength test according to [Clause 5](#).

11 Oxygen ageing

All synthetic or non-metallic parts of components which provide a fuel containing seal, for which a satisfactory declaration of properties is not submitted by the applicant (see ISO 12614-1:2014, 4.5) shall, when tested, not crack or show visible evidence of deterioration after oxygen ageing in accordance with the following test method.

Representative samples shall be subjected to 96 h exposure to oxygen at a temperature of $70\text{ }^{\circ}\text{C}$ at 20 bar in accordance with ISO 188.

12 Electrical overvoltages

All electrical components or devices containing electrical subcomponents shall withstand application of 1,5 times the rated voltage $\pm 5\%$ for periods of 3 min without failure.

13 Non-metallic material immersion

13.1 Non-metallic material used in a component shall be subjected by the test agency to the tests described in [13.2](#), except where the applicant submits declarations of results of tests carried out on the material provided by the manufacturer.

13.2 A part made of non-metallic material in contact with natural gas shall not show excessive change in volume or weight when tested according to the following procedure.

- a) Prepare, measure, and weigh a representative sample or samples of each non-metallic material used in a component, then immerse the sample or samples at room temperature in natural gas at a pressure 30 bar for a minimum of 70 h.
- b) Immediately following this period of immersion, rapidly reduce the test pressure to atmospheric pressure without causing shredding or disintegration.

No tested sample shall exhibit swelling greater than 25 % or shrinkage greater than 1 %. The weight change shall not exceed 10 %.

14 Vibration resistance

All components with moving parts shall remain undamaged, and shall continue to operate and meet the requirements of their leakage tests and hydrostatic strength test after vibration, carried out according to the following test procedure.

Vibrate the component, pressurized to its working pressure with dry air, nitrogen, or natural gas and sealed at both ends, for 30 min along each of the three orthogonal axes at the most severe resonant frequency determined as follows:

- a) by an acceleration of 1,5 g;
- b) within a sinusoidal frequency range of 10 Hz to 500 Hz;
- c) with a sweep time of 10 min.

If the resonance frequency is not found in this range, the test shall be conducted at 500 Hz.

At the completion of the test, the component shall not show any indication of fatigue or component damage, and shall comply with the leakage test specified in [Clause 6](#) and the hydrostatic strength test specified in [Clause 5](#).

15 Brass material compatibility

All brass components or subcomponents which are fuel containing for which a satisfactory declaration of properties is not submitted by the applicant shall be tested as described below.

Component manufacturers that can provide documentation attesting to the field worthiness of their products can be exempted from this requirement. Otherwise, the following test method is applied.

Each test sample shall be subjected to the physical stresses normally imposed on or within a part as a result of assembly with other components. Such stresses shall be applied to the sample prior to and maintained during the test. Samples with thread, intended to be used for installing the product in the

field, shall have the threads engaged and tightened to the torque specified in the instruction manual of the sample. Polytetrafluorethylene (PTFE) tape or pipe compounds shall not be used on the threads.

Three samples shall be degreased and then continuously exposed to a set position for 10 d to a moist ammonia-air mixture maintained in a glass chamber approximately 30 l having a glass cover.

Approximately 600 cm³ aqueous ammonia having a specific gravity of 0,94 shall be maintained at the bottom of the glass chamber below the samples. The samples shall be positioned 40 mm above the aqueous ammonia solution and supported by an inert tray. The moist ammonia-air mixture in the chamber shall be maintained at atmospheric pressure and at a temperature of 34 °C ± 2 °C.

After being subjected to the conditions described above, the sample shall show no evidence of cracking when examined using a 25x magnification.

Bibliography

- [1] ISO 3833:1977, *Road vehicles — Types — Terms and definitions*
- [2] ISO 12614 (all parts), *Road vehicles — Liquefied natural gas (CNG) fuel system components*

British Standards Institution (BSI)

BSI is the national body responsible for preparing British Standards and other standards-related publications, information and services.

BSI is incorporated by Royal Charter. British Standards and other standardization products are published by BSI Standards Limited.

About us

We bring together business, industry, government, consumers, innovators and others to shape their combined experience and expertise into standards-based solutions.

The knowledge embodied in our standards has been carefully assembled in a dependable format and refined through our open consultation process. Organizations of all sizes and across all sectors choose standards to help them achieve their goals.

Information on standards

We can provide you with the knowledge that your organization needs to succeed. Find out more about British Standards by visiting our website at bsigroup.com/standards or contacting our Customer Services team or Knowledge Centre.

Buying standards

You can buy and download PDF versions of BSI publications, including British and adopted European and international standards, through our website at bsigroup.com/shop, where hard copies can also be purchased.

If you need international and foreign standards from other Standards Development Organizations, hard copies can be ordered from our Customer Services team.

Subscriptions

Our range of subscription services are designed to make using standards easier for you. For further information on our subscription products go to bsigroup.com/subscriptions.

With **British Standards Online (BSOL)** you'll have instant access to over 55,000 British and adopted European and international standards from your desktop. It's available 24/7 and is refreshed daily so you'll always be up to date.

You can keep in touch with standards developments and receive substantial discounts on the purchase price of standards, both in single copy and subscription format, by becoming a **BSI Subscribing Member**.

PLUS is an updating service exclusive to BSI Subscribing Members. You will automatically receive the latest hard copy of your standards when they're revised or replaced.

To find out more about becoming a BSI Subscribing Member and the benefits of membership, please visit bsigroup.com/shop.

With a **Multi-User Network Licence (MUNL)** you are able to host standards publications on your intranet. Licences can cover as few or as many users as you wish. With updates supplied as soon as they're available, you can be sure your documentation is current. For further information, email bsmusales@bsigroup.com.

BSI Group Headquarters

389 Chiswick High Road London W4 4AL UK

Revisions

Our British Standards and other publications are updated by amendment or revision.

We continually improve the quality of our products and services to benefit your business. If you find an inaccuracy or ambiguity within a British Standard or other BSI publication please inform the Knowledge Centre.

Copyright

All the data, software and documentation set out in all British Standards and other BSI publications are the property of and copyrighted by BSI, or some person or entity that owns copyright in the information used (such as the international standardization bodies) and has formally licensed such information to BSI for commercial publication and use. Except as permitted under the Copyright, Designs and Patents Act 1988 no extract may be reproduced, stored in a retrieval system or transmitted in any form or by any means – electronic, photocopying, recording or otherwise – without prior written permission from BSI. Details and advice can be obtained from the Copyright & Licensing Department.

Useful Contacts:

Customer Services

Tel: +44 845 086 9001

Email (orders): orders@bsigroup.com

Email (enquiries): cservices@bsigroup.com

Subscriptions

Tel: +44 845 086 9001

Email: subscriptions@bsigroup.com

Knowledge Centre

Tel: +44 20 8996 7004

Email: knowledgecentre@bsigroup.com

Copyright & Licensing

Tel: +44 20 8996 7070

Email: copyright@bsigroup.com



...making excellence a habit.™