

BS ISO 12573:2010



BSI Standards Publication

# Aircraft — Tubing tolerances — Inch series

NO COPYING WITHOUT BSI PERMISSION EXCEPT AS PERMITTED BY COPYRIGHT LAW

*raising standards worldwide*<sup>™</sup>

Copyright British Standards Institution  
Provided by IHS under license with BSI - Uncontrolled Copy  
No reproduction or networking permitted without license from IHS

Not for Resale



**National foreword**

This British Standard is the UK implementation of ISO 12573:2010.

The UK participation in its preparation was entrusted to Technical Committee ACE/69, Aerospace hydraulic systems, fluids and components.

A list of organizations represented on this committee can be obtained on request to its secretary.

This publication does not purport to include all the necessary provisions of a contract. Users are responsible for its correct application.

© BSI 2010

ISBN 978 0 580 64200 5

ICS 49.080

**Compliance with a British Standard cannot confer immunity from legal obligations.**

This British Standard was published under the authority of the Standards Policy and Strategy Committee on 30 September 2010.

**Amendments issued since publication**

| Date | Text affected |
|------|---------------|
|------|---------------|

---

# INTERNATIONAL STANDARD

BS ISO 12573:2010

**ISO**  
**12573**

First edition  
2010-09-15

---

---

## **Aircraft — Tubing tolerances — Inch series**

*Aéronefs — Tolérances de tuyauterie — Série en inches*



Reference number  
ISO 12573:2010(E)

© ISO 2010

**PDF disclaimer**

This PDF file may contain embedded typefaces. In accordance with Adobe's licensing policy, this file may be printed or viewed but shall not be edited unless the typefaces which are embedded are licensed to and installed on the computer performing the editing. In downloading this file, parties accept therein the responsibility of not infringing Adobe's licensing policy. The ISO Central Secretariat accepts no liability in this area.

Adobe is a trademark of Adobe Systems Incorporated.

Details of the software products used to create this PDF file can be found in the General Info relative to the file; the PDF-creation parameters were optimized for printing. Every care has been taken to ensure that the file is suitable for use by ISO member bodies. In the unlikely event that a problem relating to it is found, please inform the Central Secretariat at the address given below.



**COPYRIGHT PROTECTED DOCUMENT**

© ISO 2010

All rights reserved. Unless otherwise specified, no part of this publication may be reproduced or utilized in any form or by any means, electronic or mechanical, including photocopying and microfilm, without permission in writing from either ISO at the address below or ISO's member body in the country of the requester.

ISO copyright office  
Case postale 56 • CH-1211 Geneva 20  
Tel. + 41 22 749 01 11  
Fax + 41 22 749 09 47  
E-mail [copyright@iso.org](mailto:copyright@iso.org)  
Web [www.iso.org](http://www.iso.org)

Published in Switzerland

-----

# Contents

Page

|   |    |
|---|----|
| Foreword .....                                    | iv |
| Introduction.....                                 | v  |
| 1 Scope .....                                     | 1  |
| 2 Normative references .....                      | 1  |
| 3 Terms and definitions .....                     | 1  |
| 4 Tubes in titanium and titanium alloys .....     | 4  |
| 4.1 Dimensions .....                              | 4  |
| 4.2 Tolerances .....                              | 4  |
| 5 Tubes in aluminium alloys.....                  | 5  |
| 5.1 Dimensions .....                              | 5  |
| 5.2 Tolerances .....                              | 6  |
| 6 Tubes in corrosion resistant steel (CRES) ..... | 7  |
| 6.1 Dimensions .....                              | 7  |
| 6.2 Tolerances .....                              | 7  |
| 7 Tubes in nickel alloys .....                    | 8  |
| 7.1 Dimensions .....                              | 8  |
| 7.2 Tolerances .....                              | 9  |

## Foreword

ISO (the International Organization for Standardization) is a worldwide federation of national standards bodies (ISO member bodies). The work of preparing International Standards is normally carried out through ISO technical committees. Each member body interested in a subject for which a technical committee has been established has the right to be represented on that committee. International organizations, governmental and non-governmental, in liaison with ISO, also take part in the work. ISO collaborates closely with the International Electrotechnical Commission (IEC) on all matters of electrotechnical standardization.

International Standards are drafted in accordance with the rules given in the ISO/IEC Directives, Part 2.

The main task of technical committees is to prepare International Standards. Draft International Standards adopted by the technical committees are circulated to the member bodies for voting. Publication as an International Standard requires approval by at least 75 % of the member bodies casting a vote.

Attention is drawn to the possibility that some of the elements of this document may be the subject of patent rights. ISO shall not be held responsible for identifying any or all such patent rights.

ISO 12573 was prepared by Technical Committee ISO/TC 20, *Aircraft and space vehicles*, Subcommittee SC 10, *Aerospace fluid systems and components*.

## Introduction

The purpose of this International Standard is to harmonize the dimensional tolerances used in the preparation of aerospace tubing. It is intended that future aerospace tubing standards refer to this International Standard for the purpose of defining dimensional tolerances.

International Standards use the International System of units (SI); however, large segments of the aerospace industry make use of other measurement systems as a matter of common working practice. The title of this International Standard (“Inch series”) reflects the fact that nominal sizes (see definition 3.1), which are in common use in the aerospace industry, were originally defined in terms of fractional inches.

Although tube sizes were originally defined (and are frequently cited) using non-SI units, all dimensions used in this International Standard are given in SI units, with inch units also indicated for the convenience of the user.

The decimal sign used in International Standards is the comma (“,”); however, the comma is not used in common working practice for inch dimensions. Therefore, in common with many other aerospace standards, the decimal point is used in this International Standard when providing dimensions in inches.

**NOTE** The use of non-SI units and the decimal point in this International Standard does not constitute general acceptance of measurement systems other than SI within International Standards.





# Aircraft — Tubing tolerances — Inch series

## 1 Scope

This International Standard specifies the dimensional tolerances to be applied to round section inch series tubing used in aircraft.

## 2 Normative references

The following referenced documents are indispensable for the application of this document. For dated references, only the edition cited applies. For undated references, the latest edition of the referenced document (including any amendments) applies.

ISO 8575, *Aerospace — Fluid systems — Hydraulic system tubing*

## 3 Terms and definitions

For the purposes of this document, the following terms and definitions apply.

### 3.1

#### nominal size

dash number

$d_N$

non-dimensional characteristic which identifies the size of the parts of a fluid system

NOTE For a tube, the nominal size corresponds to the nominal value of the outside diameter, expressed in sixteenths of an inch (1,59 mm).

EXAMPLE -04 corresponds to 4/16 in = 0.250 in = 6,35 mm.

### 3.2

#### outside diameter

$d_1$

distance between any two points at 180° to each other around the outside of a single section across the tube

NOTE Unless otherwise specified, the limits on the outside diameter therefore include all allowances for ovality (lack of circularity).

See Figure 1.

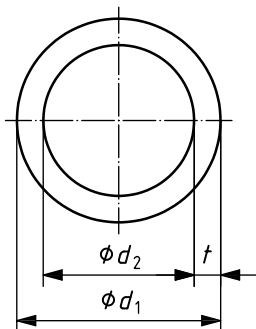

**Key**

- $d_1$  outside diameter
- $d_2$  inside diameter
- $t$  wall thickness

**Figure 1 — Outside diameter, inside diameter and wall thickness**

**3.3 mean outside diameter**  
 arithmetic mean of two measurements of the outside diameter, taken at right angles to each other around a single section across the tube

NOTE Where a mean outside diameter is specified, a limitation on ovality is also specified.

See Figure 2.

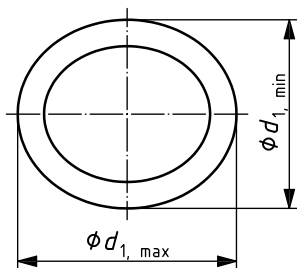

**Key**

- $d_{1, \max}$  maximum outside diameter
- $d_{1, \min}$  minimum outside diameter

mean outside diameter:  $\frac{d_{1, \max} - d_{1, \min}}{2}$

ovality:  $d_{1, \max} - d_{1, \min}$

**Figure 2 — Mean outside diameter and ovality**

**3.4 inside diameter**  
 $d_2$   
 distance between any two points at 180° to each other around the inside of a single section across the tube

NOTE Unless otherwise specified, the limits on the inside diameter shall include all allowances for ovality (lack of circularity).

See Figure 1.

**3.5**  
**wall thickness**

*t*  
 thickness measured at a right angle across the tube wall

See Figure 1.

**3.6**  
**ovality**

difference between the larger and smaller measures of the outside diameter where these are taken at right angles to each other around a single section across the tube

See Figure 2.

**3.7**  
**concentricity**

lack of coaxiality  
 axis of the outside diameter being non-coincident with the axis of the inside diameter

NOTE As the position of the axes is difficult to determine in practice, it is defined as half the variation in wall thickness at any two points at 180° to each other around a single section of the tube. Unless otherwise specified, the allowance for concentricity is contained with the permitted variation of wall thickness.

See Figure 3.

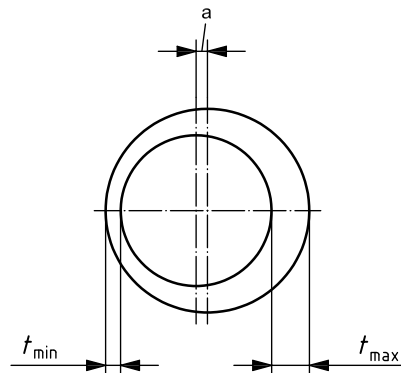

**Key**

$t_{\max}$  maximum wall thickness

$t_{\min}$  minimum wall thickness

a concentricity:  $\frac{t_{\max} - t_{\min}}{2}$

**Figure 3 — Concentricity**

**3.8**  
**straightness**

maximum curvature (depth of arc) permissible in a specified length

See Figure 4.

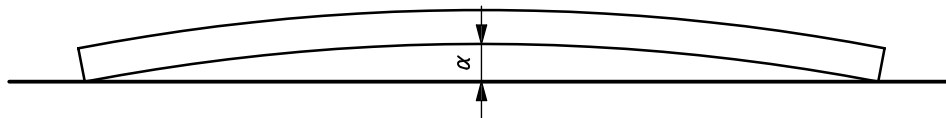

**Key**

$\alpha$  depth of arc

**Figure 4 — Straightness**

## 4 Tubes in titanium and titanium alloys

### 4.1 Dimensions

For nominal sizes and thicknesses, the standard dimensions shall be as given in ISO 8575.

### 4.2 Tolerances

#### 4.2.1 General

It is usual practice to specify tolerances on the outside diameter and one of the other two dimensional characteristics, i.e. the inside diameter and the wall thickness.

Where other specifications refer to this specification for tolerances, they shall make clear whether 4.2.3 or 4.2.4, or in special cases both, are applicable.

#### 4.2.2 Tolerances on the outside diameter

Unless otherwise specified in the order, the tolerances on the outside diameter shall be as shown in Table 1.

**Table 1 — Outside diameter tolerances — Titanium tubes**

| Nominal size<br>$d_N$ | Tolerances on outside diameter |                  |
|-----------------------|--------------------------------|------------------|
|                       | mm                             | in               |
| $d_N \leq -06$        | +0,076<br>-0                   | +0.003<br>-0     |
| $-06 < d_N \leq -10$  | +0,102<br>-0                   | +0.004<br>-0     |
| $-10 < d_N \leq -12$  | +0,102<br>-0,025               | +0.004<br>-0.001 |
| $-12 < d_N \leq -24$  | +0,102<br>-0,051               | +0.004<br>-0.002 |
| $-24 < d_N \leq -32$  | +0,130<br>-0,050               | +0.005<br>-0.002 |

#### 4.2.3 Tolerances on inside diameter

Unless otherwise specified in the order, the tolerances on the inside diameter shall be as shown in Table 2.

**Table 2 — Inside diameter tolerances — Titanium tubes**

| Nominal size<br>$d_N$ | Tolerances on inside diameter |                |
|-----------------------|-------------------------------|----------------|
|                       | mm                            | in             |
| $d_N \leq -06$        | $\pm 0,038$                   | $\pm 0.001\ 5$ |
| $-06 < d_N \leq -08$  | $\pm 0,051$                   | $\pm 0.002\ 0$ |
| $-08 < d_N \leq -12$  | $\pm 0,064$                   | $\pm 0.002\ 5$ |
| $-12 < d_N \leq -20$  | $\pm 0,076$                   | $\pm 0.003\ 0$ |
| $-20 < d_N \leq -32$  | $\pm 0,102$                   | $\pm 0.004\ 0$ |

#### 4.2.4 Tolerances on wall thickness

Unless otherwise specified in the order, the actual thickness shall be not less than 95 % of the nominal thickness.

#### 4.2.5 Tolerances on ovality

Unless otherwise specified in the order, the maximum and minimum values of the outside diameter shall remain within the limits in Table 1 and there shall be no additional allowance for ovality.

#### 4.2.6 Tolerances on concentricity

Unless otherwise specified in the order, no additional concentricity shall be permitted beyond the limits of wall thickness defined in 4.2.4.

#### 4.2.7 Tolerances on straightness

Unless otherwise specified in the order, the tube shall be of such straightness that the maximum curvature (depth of arc) shall not exceed the limits set out in Table 3.

**Table 3 — Straightness tolerances — Titanium tubes**

| Tube length |    | Maximum permissible depth of arc |       |
|-------------|----|----------------------------------|-------|
| mm          | in | mm                               | in    |
| 300         | 12 | 0,62                             | 0.025 |
| 1 500       | 60 | 3,00                             | 0.125 |

#### 4.2.8 Tolerances on fixed lengths

Unless otherwise specified in the order, for tube ordered in fixed lengths of less than 7,3 m (24 ft), the tolerance on length shall be  $\left( \begin{smallmatrix} +3,2 \\ -0 \end{smallmatrix} \right) \text{ mm} \left[ \left( \begin{smallmatrix} +0.125 \\ -0 \end{smallmatrix} \right) \text{ in} \right]$ .

## 5 Tubes in aluminium alloys

### 5.1 Dimensions

For nominal sizes and thicknesses, the standard dimensions shall be as given in ISO 8575.

## 5.2 Tolerances

### 5.2.1 Tolerances on outside diameter

Unless otherwise specified in the order, the tolerances on the outside diameter shall be as shown in Table 4.

**Table 4 — Outside diameter tolerances — Aluminium alloy tubes**

| Nominal size<br>$d_N$ | Tolerances on outside diameter |             |
|-----------------------|--------------------------------|-------------|
|                       | mm                             | in          |
| $d_N \leq -08$        | $\pm 0,08$                     | $\pm 0.003$ |
| $-08 < d_N \leq -16$  | $\pm 0,10$                     | $\pm 0.004$ |
| $-16 < d_N \leq -32$  | $\pm 0,13$                     | $\pm 0.005$ |
| $-32 < d_N \leq -48$  | $\pm 0,15$                     | $\pm 0.006$ |

### 5.2.2 Tolerances on wall thickness

Unless otherwise specified in the order, the tolerance on wall thickness shall be as shown in Table 5.

**Table 5 — Wall thickness tolerances — Aluminium alloy tubes**

| Nominal wall thickness of tube |                        | Tolerances on wall thickness |             |
|--------------------------------|------------------------|------------------------------|-------------|
| mm                             | in                     | mm                           | in          |
| $0,25 < t \leq 0,89$           | $0.010 < t \leq 0.035$ | $\pm 0,05$                   | $\pm 0.002$ |
| $0,89 < t \leq 1,24$           | $0.035 < t \leq 0.049$ | $\pm 0,08$                   | $\pm 0.003$ |
| $1,24 < t \leq 2,11$           | $0.049 < t \leq 0.083$ | $\pm 0,10$                   | $\pm 0.004$ |
| $2,11 < t \leq 3,05$           | $0.083 < t \leq 0.120$ | $\pm 0,13$                   | $\pm 0.005$ |

### 5.2.3 Tolerances on ovality

Unless otherwise specified in the order, the maximum and minimum values of the outside diameter shall remain within the limits in Table 3 and there shall be no additional allowance for ovality, except where wall thickness is less than 3 % of the outside diameter. In such cases, the values of Table 3 are taken to represent the limits of mean outside diameter and an additional 1 % ovality may be permitted.

### 5.2.4 Tolerances on concentricity

Unless otherwise specified in the order, no additional concentricity shall be permitted beyond the limits of wall thickness defined in Table 5.

### 5.2.5 Tolerances on straightness

Unless otherwise specified in the order, the tube shall be of such straightness that the maximum curvature (depth of arc) shall not exceed the limits specified in Table 6.

**Table 6 — Straightness tolerances — Aluminium alloy tubes**

| Tube size            | Maximum permissible depth of arc |                         |
|----------------------|----------------------------------|-------------------------|
|                      | (in 1 m length)<br>mm            | (in 12 in length)<br>in |
| $d_N \leq -06$       | 2,10                             | 0.025                   |
| $-06 < d_N \leq -40$ | 0,83                             | 0.010                   |

### 5.2.6 Tolerances on fixed lengths

For tube ordered in fixed lengths of 3,7 m (12 ft) or less, the tolerance on length shall be:

$$\left( \begin{matrix} +3,2 \\ -0 \end{matrix} \right) \text{mm} \left[ \left( \begin{matrix} +0.125 \\ -0 \end{matrix} \right) \text{in} \right].$$

For tube ordered in fixed lengths of 7,3 m (24 ft) or less, the tolerance on length shall be:

$$\left( \begin{matrix} +6,3 \\ -0 \end{matrix} \right) \text{mm} \left[ \left( \begin{matrix} +0.250 \\ -0 \end{matrix} \right) \text{in} \right].$$

## 6 Tubes in corrosion resistant steel (CRES)

### 6.1 Dimensions

For nominal sizes and thicknesses, the standard dimensions shall be as given in ISO 8575.

### 6.2 Tolerances

#### 6.2.1 Tolerances on outside diameter

Unless otherwise specified in the order, the tolerances on the outside diameter shall be as shown in Table 7.

**Table 7 — Outside diameter tolerances — CRES tubes**

| Nominal size<br>$d_N$ | Tolerances on outside diameter |             |
|-----------------------|--------------------------------|-------------|
|                       | mm                             | in          |
| $d_N \leq -08$        | $\pm 0,08$                     | $\pm 0.003$ |
| $-08 < d_N \leq -16$  | $\pm 0,10$                     | $\pm 0.004$ |
| $-16 < d_N \leq -24$  | $\pm 0,13$                     | $\pm 0.005$ |
| $-24 < d_N \leq -32$  | $\pm 0,15$                     | $\pm 0.006$ |
| $-32 < d_N \leq -40$  | $\pm 0,20$                     | $\pm 0.007$ |
| $-40 < d_N \leq -48$  | $\pm 0,25$                     | $\pm 0.010$ |

#### 6.2.2 Tolerances on thickness

Unless otherwise specified in the order, the tolerance on thickness is  $\pm 10\%$ .

### 6.2.3 Tolerances on ovality

Unless otherwise specified in the order, the maximum and minimum values of the outside diameter shall remain within the limits in Table 5 and there shall be no additional allowance for ovality.

### 6.2.4 Tolerances on concentricity

Unless otherwise specified in the order, no additional concentricity shall be permitted beyond the limits of wall thickness defined in 6.2.2.

### 6.2.5 Tolerances on straightness

Unless otherwise specified in the order, the tube shall be of such straightness that the maximum curvature (depth of arc) shall not exceed the limits specified in Table 8.

Table 8 — Straightness tolerances — CRES tubes

| Tube length |    | Maximum permissible depth of arc |       |
|-------------|----|----------------------------------|-------|
| mm          | in | mm                               | in    |
| 300         | 12 | 0,62                             | 0.025 |
| 1 500       | 60 | 3,00                             | 0.125 |

### 6.2.6 Tolerances on fixed lengths

Unless otherwise specified in the order, for tube ordered in fixed lengths of less than 7,3 m (24 ft) the tolerance on length shall be  $\left( \begin{smallmatrix} +3,2 \\ -0 \end{smallmatrix} \right) \text{mm}$   $\left[ \left( \begin{smallmatrix} +0.125 \\ -0 \end{smallmatrix} \right) \text{in} \right]$ .

## 7 Tubes in nickel alloys

### 7.1 Dimensions

For nominal sizes and thicknesses, the standard dimensions are indicated in Table 9.



Table 9 — Nominal sizes and thicknesses for nickel alloy tubes

| Nominal size<br>$d_N$ | Outside diameter<br>$d_1$<br>mm<br>(in) | Wall thickness<br>$t$ |                       |                       |                       |                       |                       |                       |
|-----------------------|---|-----------------------|-----------------------|-----------------------|-----------------------|-----------------------|-----------------------|-----------------------|
|                       |   | 0,71 mm<br>(0.028 in) | 0,81 mm<br>(0.032 in) | 0,89 mm<br>(0.035 in) | 0,99 mm<br>(0.039 in) | 1,07 mm<br>(0.042 in) | 1,14 mm<br>(0.045 in) | 1,24 mm<br>(0.049 in) |
|                       |   |                       |                       |                       |                       |                       |                       |                       |
| -04                   | 6,350 0<br>(0.250 0)                    | a                     | —                     | a                     | —                     | —                     | —                     | —                     |
| -05                   | 7,937 5<br>(0.312 5)                    | a                     | —                     | a                     | —                     | —                     | —                     | —                     |
| -06                   | 9,525 0<br>(0.375 0)                    | a                     | —                     | a                     | —                     | —                     | —                     | —                     |
| -08                   | 12,700 0<br>(0.500 0)                   | a                     | —                     | a                     | —                     | a                     | —                     | a                     |
| -10                   | 15,875 0<br>(0.625 0)                   | a                     | —                     | a                     | —                     | a                     | —                     | a                     |
| -12                   | 19,050 0<br>(0.750 0)                   | a                     | —                     | a                     | —                     | a                     | —                     | a                     |
| -16                   | 25,400 0<br>(1.000 0)                   | a                     | —                     | a                     | —                     | a                     | —                     | a                     |
| -20                   | 31,750 0<br>(1.250 0)                   | a                     | —                     | a                     | —                     | a                     | —                     | a                     |
| -24                   | 38,100 0<br>(1.500 0)                   | a                     | —                     | a                     | —                     | a                     | —                     | a                     |
| -28                   | 44,450 0<br>(1.750 0)                   | a                     | —                     | a                     | —                     | a                     | —                     | a                     |
| -32                   | 50,800 0<br>(2.000 0)                   | a                     | —                     | a                     | —                     | a                     | —                     | a                     |
| -40                   | 63,500 0<br>(2.500 0)                   | —                     | —                     | —                     | —                     | —                     | —                     | —                     |
| -48                   | 76,200 0<br>(3.000 0)                   | —                     | —                     | —                     | —                     | —                     | —                     | —                     |

<sup>a</sup> Standard dimension.

## 7.2 Tolerances

### 7.2.1 Tolerances on outside diameter

Unless otherwise specified in the order, the tolerances on the outside diameter shall be as shown in Table 10.

**Table 10 — Outside diameter tolerances — Nickel alloy tubes**

| Nominal size<br>$d_N$ | Tolerances on outside diameter |             |
|-----------------------|--------------------------------|-------------|
|                       | mm                             | in          |
| $d_N \leq -06$        | $\pm 0,10$                     | $\pm 0.004$ |
| $-06 < d_N \leq -10$  | $\pm 0,13$                     | $\pm 0.005$ |
| $-10 < d_N \leq -24$  | $\pm 0,20$                     | $\pm 0.007$ |
| $-24 < d_N \leq -48$  | $\pm 0,25$                     | $\pm 0.010$ |

### 7.2.2 Tolerances on thickness

Unless otherwise specified in the order, the tolerance on thickness is  $\pm 10\%$ .

### 7.2.3 Tolerances on ovality

Unless otherwise specified in the order, the maximum and minimum values of the outside diameter shall remain within the limits in Table 7 and there shall be no additional allowance for ovality.

### 7.2.4 Tolerances on concentricity

Unless otherwise specified in the order, no additional concentricity shall be permitted beyond the limits of wall thickness defined in 7.2.2.

### 7.2.5 Tolerances on straightness

Unless otherwise specified in the order, the tube shall be of such straightness that the maximum curvature (depth of arc) shall not exceed the limits set out in Table 11.

**Table 11 — Straightness tolerances — Nickel alloy tubes**

| Tube length |    | Maximum permissible depth of arc |       |
|-------------|----|----------------------------------|-------|
| mm          | in | mm                               | in    |
| 300         | 12 | 0,62                             | 0.025 |
| 1 500       | 60 | 3,00                             | 0.125 |

### 7.2.6 Tolerances on fixed lengths

Unless otherwise specified in the order, for tube ordered in fixed lengths of less than 7,3 m (24 ft) the tolerance on length shall be  $\left( \begin{smallmatrix} +3,2 \\ -0 \end{smallmatrix} \right) \text{mm} \left[ \left( \begin{smallmatrix} +0.125 \\ -0 \end{smallmatrix} \right) \text{in} \right]$ .



---

---

**ICS 49.080**

Price based on 10 pages



# British Standards Institution (BSI)

BSI is the independent national body responsible for preparing British Standards and other standards-related publications, information and services.

It presents the UK view on standards in Europe and at the international level.

It is incorporated by Royal Charter.

## Revisions

British Standards are updated by amendment or revision. Users of British Standards should make sure that they possess the latest amendments or editions.

It is the constant aim of BSI to improve the quality of our products and services. We would be grateful if anyone finding an inaccuracy or ambiguity while using this British Standard would inform the Secretary of the technical committee responsible, the identity of which can be found on the inside front cover.

**Tel: +44 (0)20 8996 9001 Fax: +44 (0)20 8996 7001**

BSI offers Members an individual updating service called PLUS which ensures that subscribers automatically receive the latest editions of standards.

**Tel: +44 (0)20 8996 7669 Fax: +44 (0)20 8996 7001**

**Email: [plus@bsigroup.com](mailto:plus@bsigroup.com)**

## Buying standards

You may buy PDF and hard copy versions of standards directly using a credit card from the BSI Shop on the website [www.bsigroup.com/shop](http://www.bsigroup.com/shop). In addition all orders for BSI, international and foreign standards publications can be addressed to BSI Customer Services.

**Tel: +44 (0)20 8996 9001 Fax: +44 (0)20 8996 7001**

**Email: [orders@bsigroup.com](mailto:orders@bsigroup.com)**

In response to orders for international standards, it is BSI policy to supply the BSI implementation of those that have been published as British Standards, unless otherwise requested.

## Information on standards

BSI provides a wide range of information on national, European and international standards through its Knowledge Centre.

**Tel: +44 (0)20 8996 7004 Fax: +44 (0)20 8996 7005**

**Email: [knowledgecentre@bsigroup.com](mailto:knowledgecentre@bsigroup.com)**

Various BSI electronic information services are also available which give details on all its products and services.

**Tel: +44 (0)20 8996 7111 Fax: +44 (0)20 8996 7048**

**Email: [info@bsigroup.com](mailto:info@bsigroup.com)**

BSI Subscribing Members are kept up to date with standards developments and receive substantial discounts on the purchase price of standards. For details of these and other benefits contact Membership Administration.

**Tel: +44 (0)20 8996 7002 Fax: +44 (0)20 8996 7001**

**Email: [membership@bsigroup.com](mailto:membership@bsigroup.com)**

Information regarding online access to British Standards via British Standards Online can be found at [www.bsigroup.com/BSOL](http://www.bsigroup.com/BSOL)

Further information about BSI is available on the BSI website at [www.bsigroup.com/standards](http://www.bsigroup.com/standards)

## Copyright

Copyright subsists in all BSI publications. BSI also holds the copyright, in the UK, of the publications of the international standardization bodies. Except as permitted under the Copyright, Designs and Patents Act 1988 no extract may be reproduced, stored in a retrieval system or transmitted in any form or by any means – electronic, photocopying, recording or otherwise – without prior written permission from BSI. This does not preclude the free use, in the course of implementing the standard of necessary details such as symbols, and size, type or grade designations. If these details are to be used for any other purpose than implementation then the prior written permission of BSI must be obtained. Details and advice can be obtained from the Copyright & Licensing Manager.

**Tel: +44 (0)20 8996 7070**

**Email: [copyright@bsigroup.com](mailto:copyright@bsigroup.com)**

## BSI Group Headquarters

389 Chiswick High Road London W4 4AL UK

Tel +44 (0)20 8996 9001

Fax +44 (0)20 8996 7001

[www.bsigroup.com/standards](http://www.bsigroup.com/standards)

*raising standards worldwide™*

Copyright British Standards Institution  
Provided by IHS under license with BSI - Uncontrolled Copy  
No reproduction or networking permitted without license from IHS

Not for Resale

