

BS ISO 12509:2004



BSI Standards Publication

Earth-moving machinery — Lighting, signalling and marking lights, and reflex- reflector devices

National foreword

This British Standard is the UK implementation of ISO 12509:2004. It supersedes BS 6912-21:1996 which is withdrawn.

The UK participation in its preparation was entrusted by Technical Committee B/513, Construction equipment and plant and site safety, to Subcommittee B/513/1, Earth moving machinery (International).

A list of organizations represented on this committee can be obtained on request to its secretary.

This publication does not purport to include all the necessary provisions of a contract. Users are responsible for its correct application.

© The British Standards Institution 2016.

Published by BSI Standards Limited 2016

ISBN 978 0 580 53759 2

ICS 53.100

Compliance with a British Standard cannot confer immunity from legal obligations.

This British Standard was published under the authority of the Standards Policy and Strategy Committee on 31 August 2016.

Amendments/corrigenda issued since publication

| Date | Text affected |
|-------------|----------------------|
|-------------|----------------------|

INTERNATIONAL STANDARD

ISO 12509

Second edition
2004-12-15

Earth-moving machinery — Lighting, signalling and marking lights, and reflex- reflector devices

*Engins de terrassement — Feux d'éclairage, de signalisation, de
position et d'encombrement, et catadioptrés*



Reference number
ISO 12509:2004(E)

PDF disclaimer

This PDF file may contain embedded typefaces. In accordance with Adobe's licensing policy, this file may be printed or viewed but shall not be edited unless the typefaces which are embedded are licensed to and installed on the computer performing the editing. In downloading this file, parties accept therein the responsibility of not infringing Adobe's licensing policy. The ISO Central Secretariat accepts no liability in this area.

Adobe is a trademark of Adobe Systems Incorporated.

Details of the software products used to create this PDF file can be found in the General Info relative to the file; the PDF-creation parameters were optimized for printing. Every care has been taken to ensure that the file is suitable for use by ISO member bodies. In the unlikely event that a problem relating to it is found, please inform the Central Secretariat at the address given below.

© ISO 2004

All rights reserved. Unless otherwise specified, no part of this publication may be reproduced or utilized in any form or by any means, electronic or mechanical, including photocopying and microfilm, without permission in writing from either ISO at the address below or ISO's member body in the country of the requester.

ISO copyright office
Case postale 56 • CH-1211 Geneva 20
Tel. + 41 22 749 01 11
Fax + 41 22 749 09 47
E-mail copyright@iso.org
Web www.iso.org

Contents

Page

| | |
|--|-----------|
| Foreword | iv |
| Introduction | v |
| 1 Scope | 1 |
| 2 Normative references | 1 |
| 3 Terms, definitions and symbols | 1 |
| 4 General requirements | 5 |
| Annex A (normative) Lighting groups | 6 |
| Annex B (informative) Forward visibility of red lights and rearward visibility of white lights | 7 |
| Annex C (normative) Light signalling devices | 8 |
| Annex D (normative) Colorimetric characteristics of illuminating and signalling lights | 9 |
| Annex E (normative) Lighting, signalling and marking lights, and reflex-reflector devices — Data sheets | 11 |
| Annex F (informative) Location of lighting, signalling and marking lights, and reflex-reflector devices | 56 |
| Annex G (informative) Earth-moving machinery from representative machine families | 58 |
| Annex H (informative) ECE regulations for lighting and light signalling devices, lights, special warning lights, direction-indicators, retro-reflecting devices, lamps and slow-moving vehicles plate | 62 |
| Bibliography | 64 |

Foreword

ISO (the International Organization for Standardization) is a worldwide federation of national standards bodies (ISO member bodies). The work of preparing International Standards is normally carried out through ISO technical committees. Each member body interested in a subject for which a technical committee has been established has the right to be represented on that committee. International organizations, governmental and non-governmental, in liaison with ISO, also take part in the work. ISO collaborates closely with the International Electrotechnical Commission (IEC) on all matters of electrotechnical standardization.

International Standards are drafted in accordance with the rules given in the ISO/IEC Directives, Part 2.

The main task of technical committees is to prepare International Standards. Draft International Standards adopted by the technical committees are circulated to the member bodies for voting. Publication as an International Standard requires approval by at least 75 % of the member bodies casting a vote.

Attention is drawn to the possibility that some of the elements of this document may be the subject of patent rights. ISO shall not be held responsible for identifying any or all such patent rights.

ISO 12509 was prepared by Technical Committee ISO/TC 127, *Earth-moving machinery*, Subcommittee SC 2, *Safety requirements and human factors*.

This second edition cancels and replaces the first edition (ISO 12509:1995), which has been technically revised.

Introduction

Earth-moving machines are designed to function in a wide variety of operations and worksites. Their size, mass, speed, combinations and equipment also greatly vary. Therefore, the combination of lighting, signalling and marking lights, and reflex-reflector devices will differ.

This International Standard provides information needed for the selection of lighting, signalling and marking lights and reflex-reflector devices based on machine application and speed.

Earth-moving machinery — Lighting, signalling and marking lights, and reflex-reflector devices

1 Scope

This International Standard specifies the minimum requirements for installation and performance of lighting, signalling and marking lights, and reflex-reflector devices on earth-moving machines. It is applicable to self-propelled wheel or crawler earth-moving machines as defined in ISO 6165, intended for off-road, as well as on-road, use. It is not applicable to pedestrian-controlled machines.

2 Normative references

The following referenced documents are indispensable for the application of this document. For dated references, only the edition cited applies. For undated references, the latest edition of the referenced document (including any amendments) applies.

ISO 303:2002, *Road vehicles — Installation of lighting and light signalling devices for motor vehicles and their trailers*

ISO 6165, *Earth-moving machinery — Basic types — Vocabulary*

ISO 7227:1987, *Road vehicles — Lighting and light signalling devices — Vocabulary*

3 Terms, definitions and symbols

3.1 Terms and definitions

For the purposes of this document, the terms and definitions given in ISO 303, ISO 7227 and the following apply.

3.1.1

zero Y plane

vertical plane which passes through the longitudinal centreline of the machine

NOTE See ISO 6746-1.

3.1.2

X plane

any vertical plane normal to the Y plane

NOTE See ISO 6746-1.

3.1.3

ground reference plane

GRP

plane surface on which the machine stands and which should be substantially horizontal

3.1.4

extreme outer edge

plane parallel to the median longitudinal plane of the machine and touching its lateral outer edge on either side of the machine, disregarding the projection of tyres near the point of contact with the ground and connections for tyre-pressure gauges, the projection of any anti-skid device mounted on the wheels, of rear-view mirrors, and of side direction indicator lamps, front and rear-position lamps and stopping lamps

3.1.5

overall width

distance between the two vertical planes of the extreme outer edge

3.1.6

operating mass

OM

mass of the base machine with equipment and empty attachment as specified by the manufacturer, and with the operator (75 kg), full fuel tank and all fluid systems at the levels specified by the manufacturer

[ISO 6016:1998, definition 3.2.1]

3.1.7

lamp

device designated to illuminate the road or ground (lighting) or to emit a light signal (light signalling)

NOTE Light marking is similarly regarded as a *lamp* (see ISO 7227).

3.1.7.1

equivalent lamps

lamps which have the same function and are geometrically interchangeable

[ISO 7227:1987, definition 3.8]

3.1.7.2

independent lamps

lamps which have separate illuminating surfaces, separate light sources and separate lamp bodies

[ISO 7227:1987, definition 3.9]

3.1.7.3

grouped lamps

devices which have separate illuminating sources and separate light sources but a common lamp body

[ISO 7227:1987, definition 3.10]

3.1.7.4

combined lamps

devices which have separate illuminating surfaces, but a common light source and a common lamp body

[ISO 7227:1987, definition 3.11]

3.1.7.5

reciprocally incorporated lamps

devices which have separate light sources (or a single light source operating under different conditions, totally or partially common illuminating surfaces and a common lamp body)

[ISO 7227:1987, definition 3.12]

3.1.7.6

reflex reflector

device which, by the reflection of light emanating from a light-source not connected to the machine, is used to indicate the presence of a machine or to identify a specific part of a machine to an observer near the source

3.1.8

illuminating surface

⟨lighting device⟩ orthogonal projection of the full aperture of a reflector in a transverse plane

NOTE 1 If the lighting device has no reflector, the definition of the illuminating surface of a **signalling device** (3.1.9) applies. If the lamp lens(es) extend(s) over part only of the full aperture of the reflector, then the projection of that part only is taken into account.

NOTE 2 In the case of a dipped-beam headlamp, having a screened light source giving a defined cut-off, the illuminating surface is limited by the apparent trace of the cut-off on to the lens. If the reflector and glass are adjustable relative to one another, the mean adjustment is preferred.

NOTE 3 Adapted from ISO 7227:1987.

NOTE 4 See Annex C.

3.1.9

illuminating surface

⟨signalling device other than reflex reflector⟩ orthogonal projection of the lamp in a plane perpendicular to its reference axis and in contact with the exterior light-emitting surface of a lamp, this projection being bounded by the edges of screens situated in this plane, each allowing only 98 % of the total luminous intensity of the light to persist in the reference axis direction

[ISO 7227:1987, definition 3.36]

NOTE See Annex C.

3.1.10

illuminating surface

⟨reflex reflector⟩ illuminating surface in a plane perpendicular to the reference axis and bounded by planes on the outer edges of the light projection and parallel to this axis

[ISO 7227:1987, definition 3.37]

3.1.11

reference axis

characteristic axis of the light signal for use as the reference direction ($\alpha = 0^\circ$, $\beta = 0^\circ$) for photometric measurements and when fitting the lamp on the machine

NOTE The reference axis is determined by the manufacturer (see Annex C).

3.1.12

reference centre

intersection of the reference axis with the light-emitting surface

[ISO 7227:1987, definition 3.41]

NOTE See Annex C.

3.1.13

light-emitting surface

all or part of the exterior surface of the transparent lens that encloses the lighting and light signalling devices and conforms to certain defined photometric and colorimetric conditions

[ISO 7227:1987, definition 3.38]

NOTE See Annex C.

3.1.14

control device

device indicating either that a device is operating correctly or is actuated

3.1.14.1

tell-tale

visible and/or audible device that indicates actuation and/or operating condition of lighting and light signalling devices or system

[ISO 7227:1987, definition 3.32]

3.1.14.2

operational tell-tale

tell-tale which informs the operator/driver whether a lighting or light signalling device or system that has been actuated is operating correctly or not

[ISO 7227:1987, definition 3.33]

3.1.14.3

circuit-closed tell-tale

tell-tale which informs the operator/driver whether a lighting or light signalling device or system has been switched on but not whether a lighting is operating correctly or not

[ISO 7227:1987, definition 3.34]

3.1.15

angles of geometric visibility

angles which determine the widest solid angle in which the apparent surface of a lamp is visible

NOTE The solid angle is determined by the segments of a sphere in which the centre coincides with the reference centre of the lamp and the equator is parallel to the ground. These segments are determined in relation to the reference axis. The horizontal angles correspond to the longitude and the vertical angle to the latitude. The horizontal angles are β_1 corresponding to longitude outboard, and β_2 corresponding to the longitude inboard, and the vertical angles are α_1 corresponding to the up latitude and α_2 corresponding to the down latitude (see data sheet diagram in Annex E).

3.2 Symbols

| | |
|------------|---|
| H_1 | maximum height above ground |
| H_2 | minimum height above ground |
| E | distance between outer edges of machine and illuminating surface of lighting device |
| D | distance between two lamps |
| K | distance from front of machine to edge of illuminating surface |
| K_1 | distance between edges of illuminating surface |
| α_1 | vertical angles corresponding to up latitude |
| α_2 | vertical angles corresponding to down latitude |
| β_1 | horizontal angles corresponding to longitude outboard |
| β_2 | horizontal angles corresponding to longitude inboard |
| S | minimum requirements regarding lighting, signalling and marking lights and reflex-reflector devices for on/off-road use |

- optional lighting, signalling and marking lights and reflex-reflector devices which may be installed on machines. When these lighting, signalling and marking lights and reflex-reflector devices are used, they should be in accordance with this International Standard.

N/A not applicable

4 General requirements

4.1 Installation of lighting, signalling and marking lights, and reflex-reflector devices on earth-moving machinery

4.1.1 The lighting, signalling and marking lights, and reflex-reflector devices shall be so fitted that, under normal conditions of use and especially regarding any vibration to which they could be subjected, they retain the characteristics laid down in Annex E. In particular, it shall not be possible for the lamps to be inadvertently disturbed.

4.1.2 The position, e.g. height and orientation, of the lamps shall be verified with the unladen machine on a flat, horizontal surface.

4.1.3 Lamps constituting a pair shall

- a) be fitted to the machine symmetrically in relation to the zero Y plane and at the same height above the ground, except on machines with unsymmetrical shape,
- b) satisfy the same colorimetric characteristics (see Annex D),
- c) have substantially identical photometric characteristics (see Annex D).

4.1.4 The maximum height (H_1) above ground shall be measured from the highest point, and the minimum height (H_2) from the lowest point, of the illuminating surface. When the height requirements are substantially met, it is sufficient to refer to actual lamp edges (see ISO 303).

4.1.5 The width position shall be determined from the edge of the illuminating surface which is furthest from the zero Y plane of the earth-moving machine when referred to the overall width (E), and from the inner edges of the illuminating surfaces when referred to the distance between the lamps (D). When the width requirements are substantially met, it is sufficient to refer to the actual lap edges (see ISO 303).

4.1.6 No red light shall be visible towards the front. No white light shall be visible towards the rear that could lead to confusion emitted by a lamp, other than the white light from the reversing lamp(s) or the white light from the working lamp(s). Compliance with these requirements shall be tested according to ISO 303 and Annex B. During the test, the machine shall be located on a horizontal plane and, in the case of articulated frame steering, in a straight position.

4.1.6.1 There shall be no direct visibility of a red light if viewed by an observer moving within Zone 1 in a transverse plane situated 25 m from the front wheel/track. The width of Zone 1 is determined in respect of 15° angles starting from both sides of the wheel/track gauge [see Figure B.1 a)].

4.1.6.2 There shall be no direct visibility of a white light if viewed by an observer moving within Zone 2 in a transverse plane situated 25 m from the rear wheel/track. The width of Zone 2 is determined in respect of 15° angles starting from both sides of the wheel/track gauge [see Figure B.1 b)].

4.1.7 The electrical connections shall be such that the front and rear-position lamps, and rear registration plate lamp (if any), can only be switched on and off simultaneously.

4.1.8 The electrical connections shall be such that the main/upper beam headlamp (if applicable) and dipped/lower beam headlamp and rear fog lamp (if any), cannot be switched on unless the front and rear-position lamps, and rear registration plate lamp (if any), are also switched on. This requirement shall not apply to main/upper beam or dipped/lower beam headlamps, when light signals are emitted.

4.1.9 The number of lamps fitted to the machine shall be equal to the number(s) specified in the data sheets presented in Annex E.

Annex A (normative)

Lighting groups

Lighting groups (I, II and III) are a combination of lighting, signalling and marking lights, and reflex reflectors, to be used on earth-moving machines. The guidelines given in Table A.1 differentiate depending on where the machines are intended to be used and on the maximum travelling speed of the machines.

NOTE Following these guidelines does not ensure conformance to specific national roading standards or regulations. All lighting, signalling and marking lights, and reflex-reflector devices used on machines in Lighting Group II could need to be type approved according to the national regulations.

Table A.1 — Lighting combinations

| Application to machines | Lighting groups ^a | Rated maximum travelling speed <i>v</i> (km/h) | | |
|--|------------------------------|---|-----------------------|---------------|
| | | A $v \leq 10$ | B $10 > v \leq 40$ | C $v > 40$ |
| Machines that are <i>not</i> intended for travel on public roads. ^b | I | EXAMPLE Wheel/soft crawler tractor-dozer, wheel loader, wheel excavator, wheel backhoe-loader, wheel/soft crawler dumper, grader, rubber-tyred roller and wheel trencher. | | |
| Machines that <i>are</i> intended for travel on public roads. | II | EXAMPLE Wheel/soft crawler tractor-dozer, wheel loader, wheel excavator, wheel backhoe-loader, wheel/soft crawler dumper, grader, rubber-tyred roller and wheel trencher. | | |
| Machines <i>not</i> allowed to travel on public roads due to physical characteristics exceeding road limits. | III | EXAMPLE Wheel/soft crawler tractor-dozer, loader, excavator, dumper, tractor-scraper, pipelayer and compactor. | | |
| ^a See Annex E. | | | | |
| ^b At manufacturer and user discretion. | | | | |

Annex B
 (informative)

Forward visibility of red lights and rearward visibility of white lights

Dimensions in metres

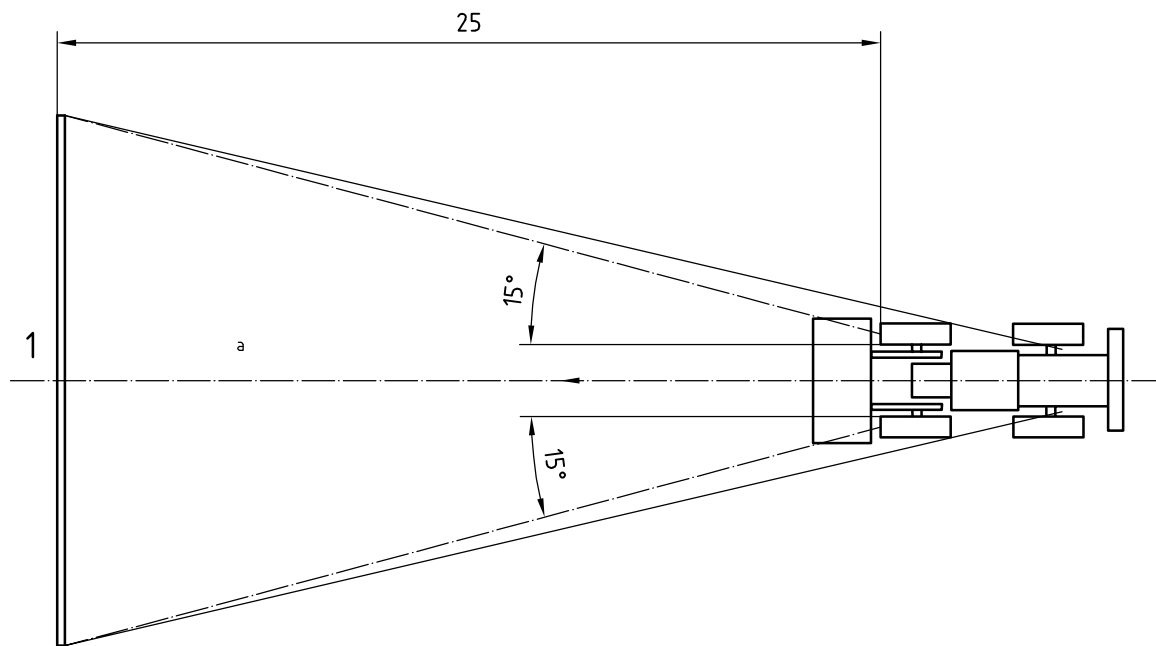

a) Forward visibility of red lights (see 4.1.6.1)

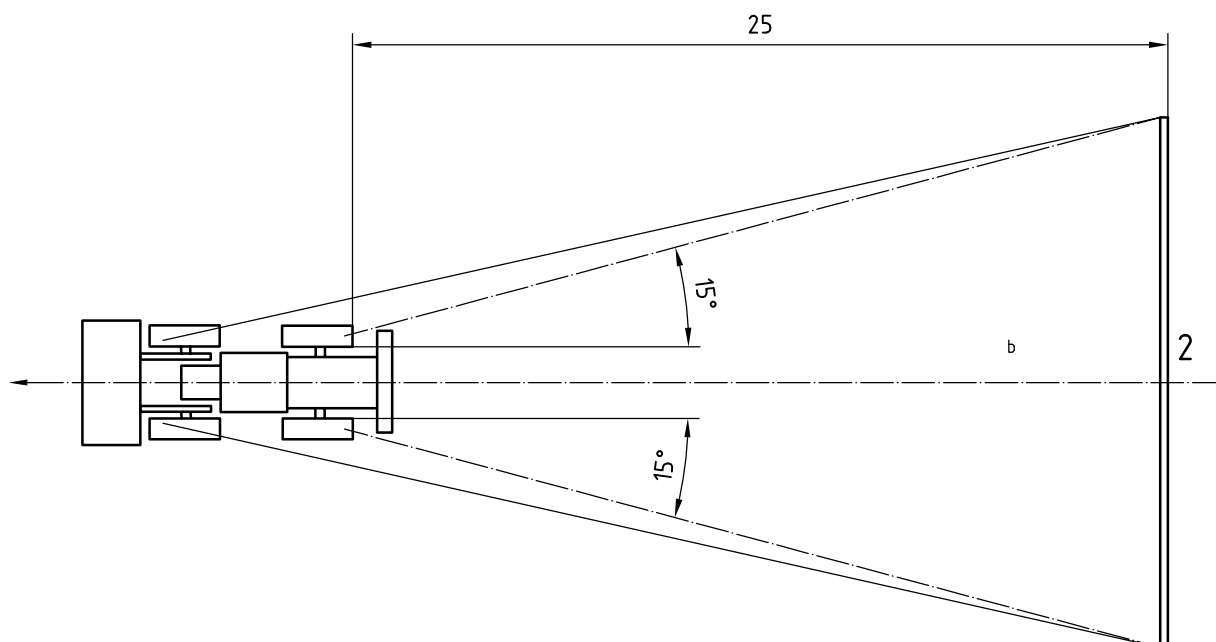

b) Rearward visibility of white lights (see 4.1.6.2)

Key

- | | | | |
|---|--------|---|-------------------------|
| 1 | Zone 1 | a | No red light visible. |
| 2 | Zone 2 | b | No white light visible. |

Figure B.1

Annex C
 (normative)

Light signalling devices

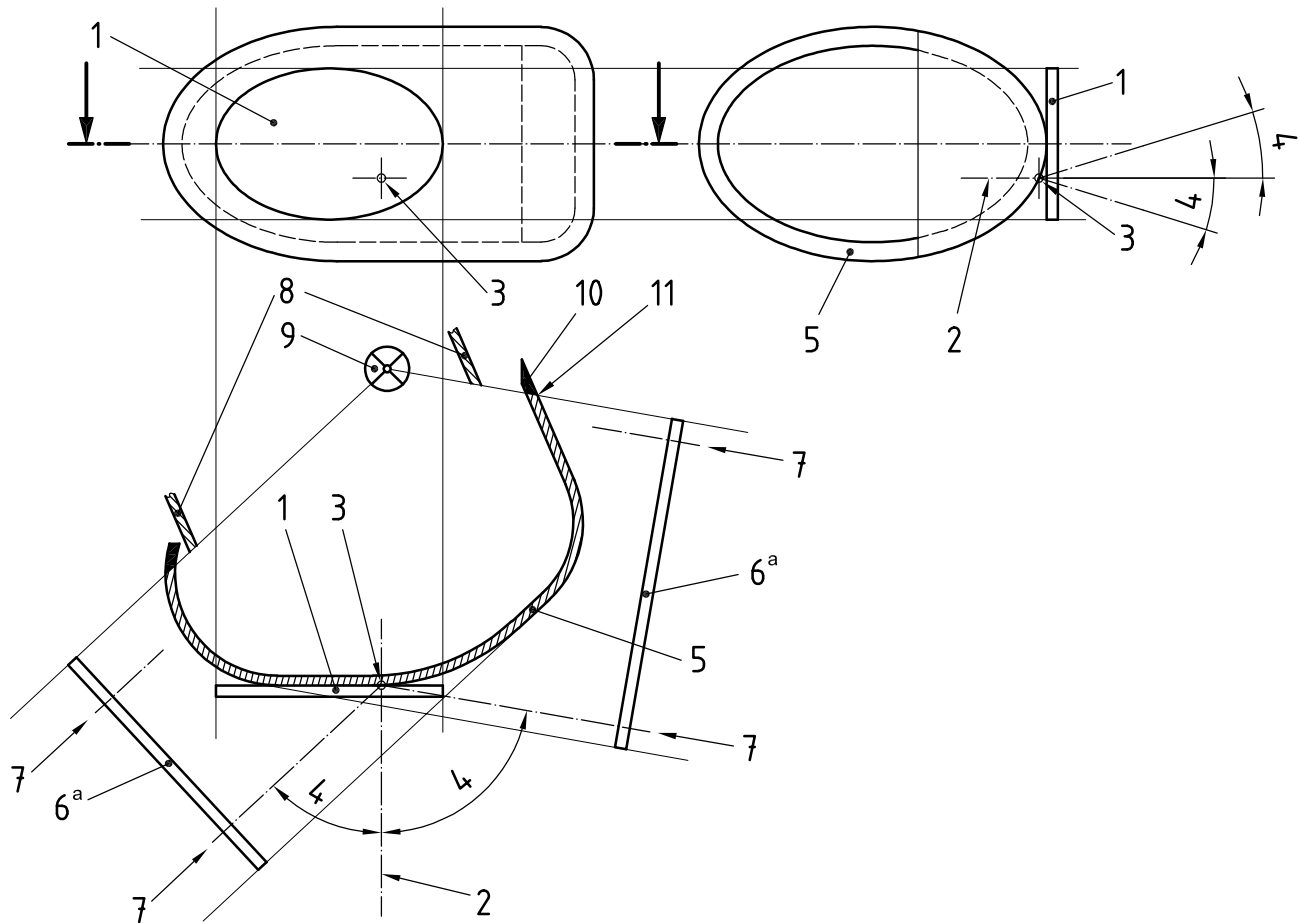

Key

- 1 illuminating surface
 - 2 reference axis
 - 3 reference centre
 - 4 angle of geometric visibility
 - 5 light-emitting surface
 - 6 apparent surface
 - 7 direction of visibility
 - 8 non-transparent surface or part
 - 9 lamp filament
 - 10 transparent part of lens
 - 11 limit of light-emitting surface
- ^a This surface shall be considered tangent to the light-emitting surface.

Figure C.1

Annex D (normative)

Colorimetric characteristics of illuminating and signalling lights

D.1 Trichromatic coordinates

The trichromatic coordinates for illuminating and signalling lights shall be in accordance with Table D.1.

See Figure D.1.

NOTE The trichromatic coordinates specified here do not necessarily conform with CIE S004 [1].

Table D.1 — Trichromatic coordinates

| | | | |
|----------------------------------|----------------|----------------|---------------------------------------|
| Red | Limit towards: | yellow | $y \leq 0,335$ |
| | | purple | $z \leq 0,008$ |
| White | Limit towards: | blue | $x \geq 0,310$ |
| | | yellow | $x \leq 0,500$ |
| | | green | $y \leq 0,150 + 0,640x$ |
| | | green | $y \leq 0,440$ |
| | | purple | $y \geq 0,050 + 0,750x$ |
| | | red | $y \geq 0,382$ |
| Amber | Limit towards: | green | $y \leq x - 0,120$ |
| | | red | $y \geq 0,398$ |
| | | white | $y = 0,790 - 0,670x$ |
| Selective yellow | Limit towards: | red | $y \geq 0,318 + 0,580x$ |
| | | green | $y \leq 1,29x - 0,100$ |
| | | white | $y \geq -x + 0,966$ |
| | | spectral value | $y \geq -x + 0,992$ |
| Enlarged selective yellow | Limit towards: | red | $y \geq 0,138 + 0,580x$ |
| | | green | $y \leq 1,290x - 0,100$ |
| | | white | $y \geq -x + 0,940$ $y \geq 0,440$ |
| | | spectral value | $y \leq -x + 0,992$ |

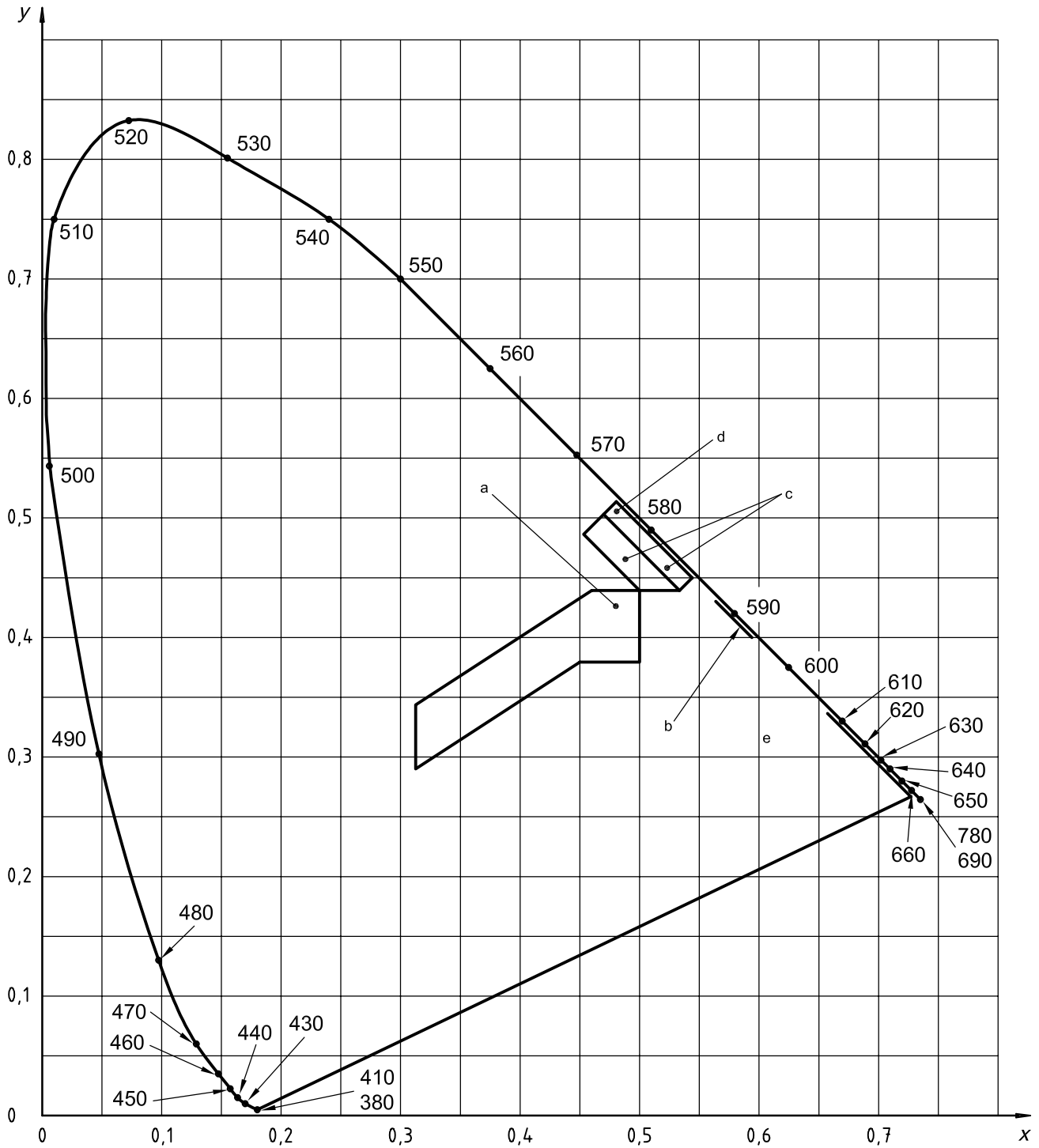

This diagram represents the zones of the CIE colour triangle, corresponding to the limits in Table D.1.

- a White.
- b Amber.
- c Enlarged selective yellow.
- d Selective yellow.
- e Red.

Figure D.1 — Calorimetric zones corresponding to recommended limits

Annex E (normative)

Lighting, signalling and marking lights, and reflex-reflector devices — Data sheets

E.0 Index to data sheets and general

The dimensions and geometric visibility specifications given in the data sheets are based on the transport and/or the carry position of the earth-moving machines as specified by the manufacturer.

Where national requirements differ from the requirements of this standard, the national requirements may be applied.

Lighting

- E.1. Dipped/lower beam headlamp (dipped-beam light)
- E.2. Main/upper beam (driving light)
- E.3. Work lamp (working light)

Signalling lights

- E.4. Reversing lamp
- E.5. Direction-indication lamp
- E.6. Hazard warning lamp
- E.7. Stop lamp

Marking lights

- E.8. Rear registration-plate lamp
- E.9. Front position lamp
- E.10. Rear-position lamp
- E.11. Rear fog lamp
- E.12. Special warning lamp

Reflex-reflectors

- E.13. Rear reflex-reflector
- E.14. Front reflex-reflector
- E.15. Side-reflex-reflector
- E.16. Slow-moving vehicle plate

E.1 Data sheet

E.1.1 Dipped/lower beam headlamp: the lamp used to illuminate the road or the ground ahead of the earth-moving machine without causing undue dazzle or discomfort to oncoming drivers and other road-users or workers.

See Figure E.1.

E.1.1.1 Colour of light: white.

E.1.1.2 Alignment: towards the front.

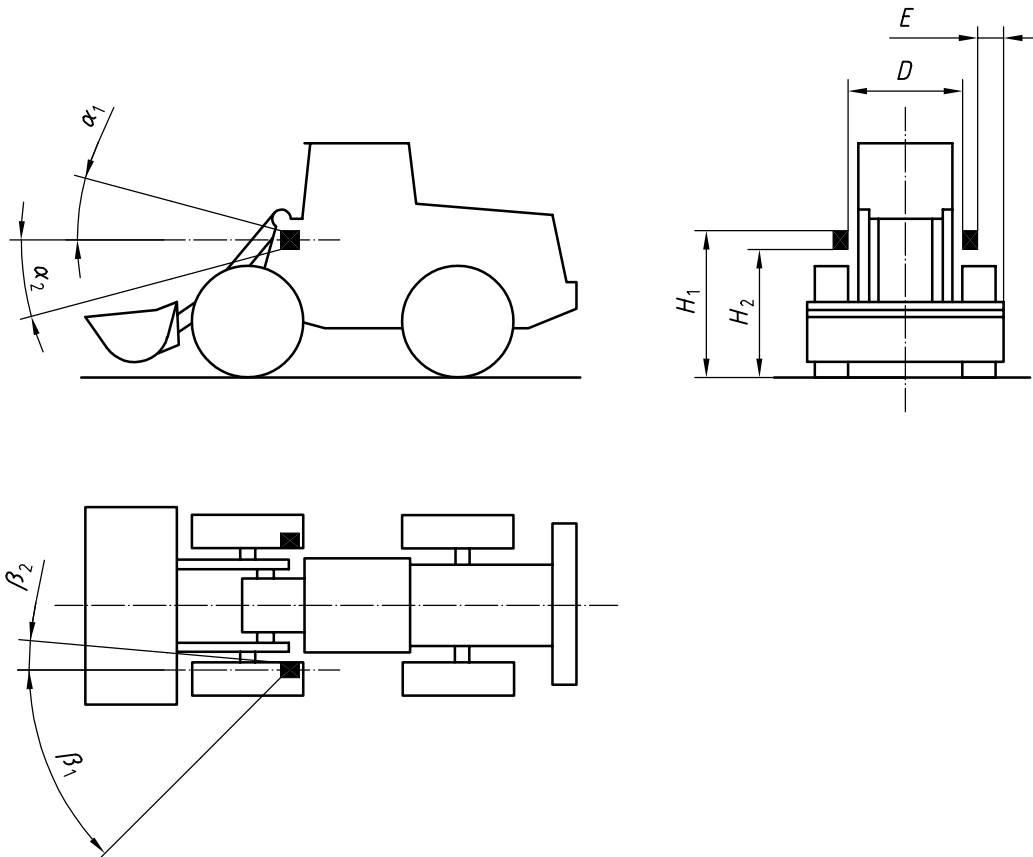

Figure E.1

E.1.1.3 Configuration: dipped/lower beam headlamp

- a) may be grouped with
 - main/upper beam headlamp, and
 - any other front lamp,
- b) shall not be combined with any other front lamp, and
- c) may be reciprocally incorporated with
 - main/upper beam headlight, and
 - any other front lamp or lamps.

E.1.2 Requirements for dipped/lower beam headlamp

| Lighting groups (see Annex A) | I | | | II | | | III | | |
|---|--|---|---|----|----------------|----------------|-----|------------------|---|
| | A | B | C | A | B | C | A | B | C |
| Application to machines | O | O | O | S | S ^a | S ^a | N/A | O | O |
| Number | Two ^b | | | | | | N/A | Two ^b | |
| Dimensions, mm | | | | | | | | | |
| H_1 | $\leq 1\,500^c$ | | | | | | N/A | $\leq 2\,100^d$ | |
| H_2 | > 500 | | | | | | N/A | > 500 | |
| E | $\leq 400^e$ | | | | | | N/A | $\leq 400^e$ | |
| D | N/A | | | | | | | | |
| Geometric visibility, min. angles | | | | | | | | | |
| α_1 | 10° | | | | | | N/A | 10° | |
| α_2 | 10^{of} | | | | | | N/A | 10^{of} | |
| β_1 | 45° | | | | | | N/A | 45° | |
| β_2 | 5°^g | | | | | | N/A | 5°^g | |
| Electrical connections | The dipped/lower beam light may remain switched on at the same time as the main/upper beam light. When the control switch for dipped/lower beam light is activated, all main/upper beam lights shall be switched off simultaneously. | | | | | | | | |
| Tell-tale | N/A | | | | | | | | |
| Other requirements | Symmetrically in relation to the median longitudinal plane ^h | | | | | | | | |
| <p>Exceptions:</p> <p>a Not applicable to steel-tracked or steel-pad-foot wheeled machines.</p> <p>b At front of the earth-moving machinery as far ahead as possible. The light shall not cause discomfort to the operator/driver either directly or indirectly through the rear-view mirror and/or other reflecting surfaces. Two additional dipped/lower beam lights are optional. For additional lamps, when used on road, exception shall be granted.</p> <p>c May be $> 1\,500$ mm if the design of the bodywork makes it impossible to keep within 1 500 mm, but maximum speed may be limited by national regulations.</p> <p>d May be $> 2\,100$ mm if the design of the bodywork makes it impossible to keep within 2 100 mm.</p> <p>e Owing to the design, may be > 400 mm from the extreme outer edge of the earth-moving machinery.</p> <p>f May be reduced to 5° if the design of the bodywork makes it necessary.</p> <p>g May be reduced to 3° if the design of the bodywork makes it necessary.</p> <p>h Initial adjustment of the cut-off line. The distance between the screen and the headlamp centre of reference shall be at 10 m.</p> <p>When the highest point of the illuminating surface of the headlamp is</p> <p>— 1 200 mm, the dipped/lower beam headlamp inclination shall be between 1,0 % and 3 %, and when</p> <p>— $> 1\,200$ mm, the adjustment of the additional dipped/lower beam headlamps mounted higher than 1 200 mm shall be such that the horizontal part of the cut-off line at a distance of 15 m in front of the earth-moving machinery is half the height of the centre of the dipped/lower beam headlamp.</p> | | | | | | | | | |

E.2 Data sheet

E.2.1 Main/upper beam headlamp: the lamp used to illuminate the road or the ground over a long distance ahead of the earth-moving machine.

See Figure E.2.

E.2.1.1 Colour of light: white.

E.2.1.2 Alignment: towards the front.

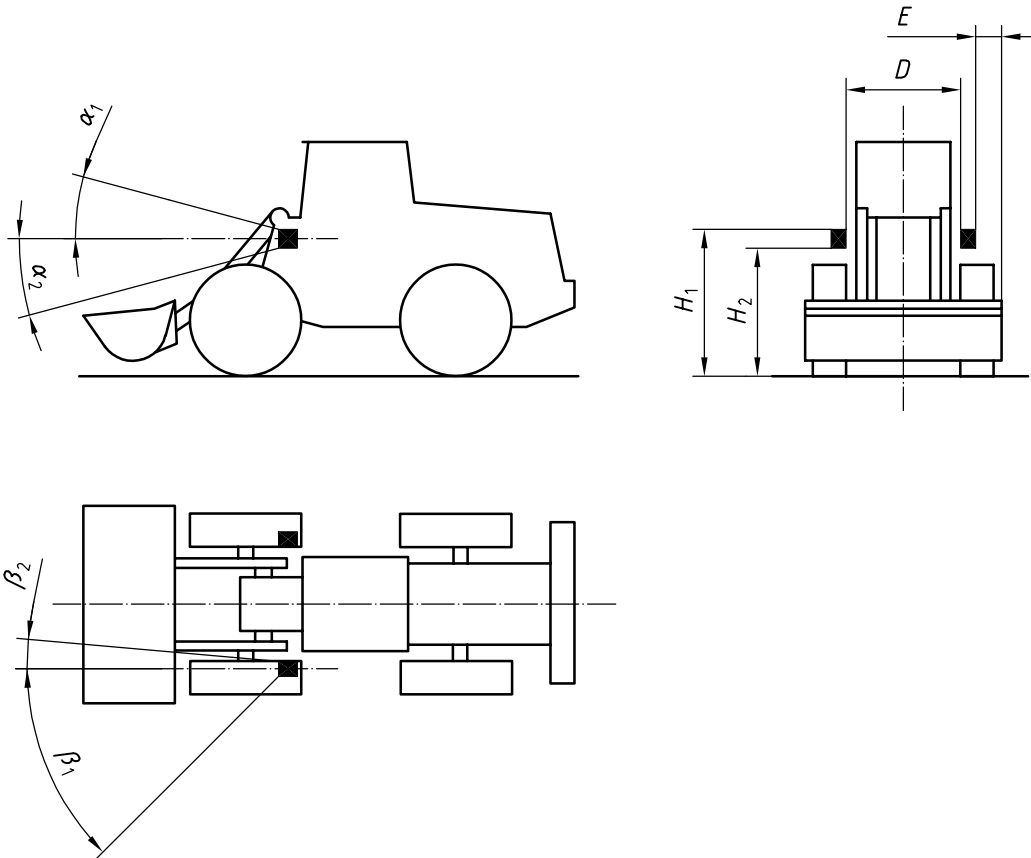

Figure E.2

E.2.1.3 Configuration: the main/upper beam headlamp

- a) may be grouped with a
 - dipped/lower beam headlamp, and
 - any other front lamp,
- b) shall not be combined with any other front lamp,
- c) may be reciprocally incorporated with a
 - dipped/lower beam headlamp, or
 - front-position lamp.

E.2.2 Requirements for main/upper beam headlamp

| Lighting groups (see Annex A) | I | | | II | | | III | | |
|--|-----|---|---|--------------------------|----------------|----------------|-----|--------------------------|----------------|
| | A | B | C | A | B | C | A | B | C |
| Application to machines | N/A | | | O | O ^a | O ^a | N/A | O ^a | O ^a |
| Number | N/A | | | Two or four ^b | | | N/A | Two or four ^b | |
| Dimensions, mm | | | | | | | | | |
| H_1 | | | | N/A | | | | | |
| H_2 | | | | N/A | | | | | |
| E | N/A | | | c | | | N/A | c | |
| D | | | | N/A | | | | | |
| Geometric visibility, min. angles | | | | | | | | | |
| α_1 | | | | N/A | | | | | |
| α_2 | | | | N/A | | | | | |
| β_1 | | | | N/A | | | | | |
| β_2 | | | | N/A | | | | | |
| Electrical connections | N/A | | | d | | | N/A | d | |
| Tell-tale | N/A | | | e | | | N/A | e | |
| Other requirements | N/A | | | f | | | N/A | f | |
| Exceptions: | | | | | | | | | |
| a Not applicable to steel-tracked or steel-pad-foot wheeled machines. | | | | | | | | | |
| b At front of the earth-moving machine as far ahead as possible. The light shall not cause discomfort to the operator/driver either directly or indirectly through the rear-view mirror and/or other reflecting surfaces. | | | | | | | | | |
| c The outer edges of the illuminating surfaces shall in no case be closer to the extreme outer edge of the earth-moving machine than the outer edges of the illuminating surfaces of the dipped/lower beam headlamp. | | | | | | | | | |
| d Shall be switched on either simultaneously or in pairs. For changing over from the dipped/lower beam headlamps to the main/upper beam headlamps, at least one pair of main/upper beam headlamps shall be switched on. For changing over from main/upper beam headlamps to dipped/lower beam headlamps, all main/upper beam headlamps shall be switched off simultaneously. | | | | | | | | | |
| e A blue warning light shall be visible in the operator's/driver's field of view, when the main-beam headlamps are switched on. | | | | | | | | | |
| f Symmetrical in relation to the median longitudinal plane of the earth-moving machinery. The total maximum intensity of the main/upper beam headlamps which can be switched on simultaneously shall not exceed 225 000 cd. | | | | | | | | | |

E.3 Data sheet

E.3.1 Work lamp: the lamp used for illuminating the working area to the front, rear or side of the earth-moving machine and/or its attachment.

See Figure E.3.

E.3.1.1 Colour of light: white.

E.3.1.2 Alignment: any direction, or all around where necessary.

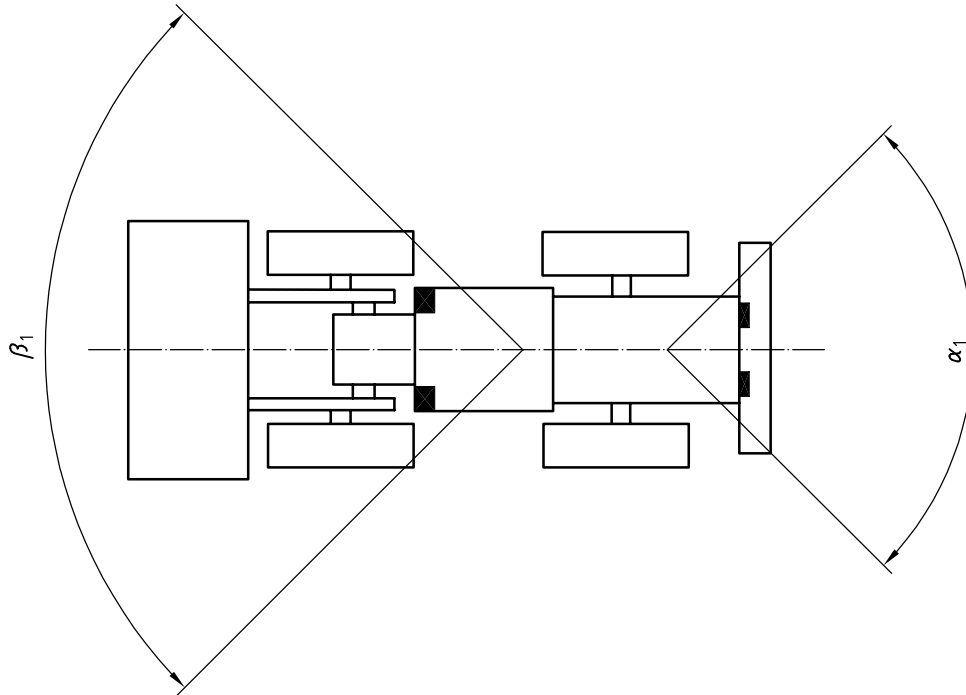

Figure E.3

E.3.1.3 Configuration: the work lamp

- a) shall not be grouped with another lamp,
- b) shall not be combined with another lamp, and
- c) shall not be reciprocally incorporated with another lamp.

E.3.2 Requirements for work lamp

| Lighting groups (see Annex A) | I | | | II | | | III | | |
|---|--|---|---|----|---|---|-----|---|---|
| | A | B | C | A | B | C | A | B | C |
| Application to machines | O | O | O | O | O | O | O | O | O |
| Number | One or more ^a | | | | | | | | |
| Dimensions, mm | | | | | | | | | |
| H_1 | N/A | | | | | | | | |
| H_2 | N/A | | | | | | | | |
| E | N/A | | | | | | | | |
| D | N/A | | | | | | | | |
| Geometric visibility, min. angles | | | | | | | | | |
| α_1^c | 90° | | | | | | | | |
| α_2 | N/A | | | | | | | | |
| β_1^d | 90° | | | | | | | | |
| β_2 | N/A | | | | | | | | |
| Electrical connections | Shall have a separate switch on control | | | | | | | | |
| Tell-tale | N/A | | | | | | | | |
| Other requirements | Working lights shall not be switched on when driving on roads ^b | | | | | | | | |
| Where national requirements differ from those given here, the national requirements may be applied. | | | | | | | | | |
| Exceptions: | | | | | | | | | |
| <p>^a A number that makes it possible to observe the actual working area of the machine and if necessary also the attachment.</p> <p>^b On machines used for construction, maintenance or cleaning of public roads, or installations at or on public roads, working lights may be switched on when driving, if driving is part of the work process. Working lights may only be switched on if no other road users or workers can be dazzled. If the machine is equipped with front and rear-position lamps, the working lights may only be switched on when the front and rear-position lamps are switched on.</p> <p>^c The angle sector lines shall cover the front-end corners of the base machine, where applicable.</p> <p>^d The angle sector lines shall cover the rear-end corners of the base machine, where applicable.</p> | | | | | | | | | |

E.4 Data sheet

E.4.1 Reversing lamp: the lamp actuated when the operator has moved the control to select the reverse direction, provided to illuminate the area to the rear of the machine.

See Figure E.4.

E.4.1.1 Colour of light: white.

E.4.1.2 Alignment: rearwards.

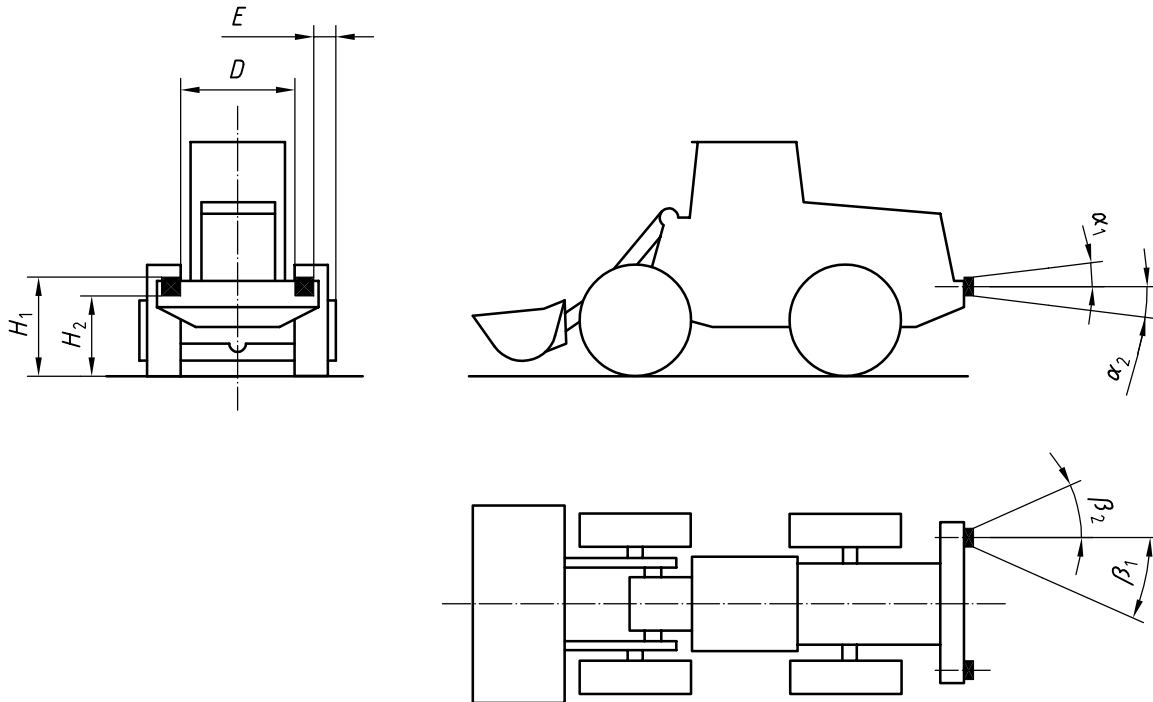

Figure E.4

E.4.1.3 Configuration: the reversing lamp

- may be grouped with any other rear lamp,
- shall not be combined with another lamp, and
- shall not be reciprocally incorporated with another lamp.

E.4.2 Requirements for reversing lamp

| Lighting groups (see Annex A) | I | | | II | | | III | | |
|---|-----------------|---|---|----|---|---|-----|---|---|
| | A | B | C | A | B | C | A | B | C |
| Application to machines | N/A | O | O | O | O | O | N/A | O | O |
| Number | One or more | | | | | | | | |
| Dimensions, in mm | | | | | | | | | |
| H_1 | $\leq 1\,500^a$ | | | | | | | | |
| H_2 | > 400 | | | | | | | | |
| E | N/A | | | | | | | | |
| D | N/A | | | | | | | | |
| Geometric visibility, min. angles | | | | | | | | | |
| α_1 | 15° | | | | | | | | |
| α_2 | 5° | | | | | | | | |
| β_1 | $45^\circ{}^b$ | | | | | | | | |
| β_2 | 45° | | | | | | | | |
| Electrical connections | c | | | | | | | | |
| Tell-tale | Optional | | | | | | | | |
| Other requirements | N/A | | | | | | | | |
| Exceptions: | | | | | | | | | |
| a In a longitudinal direction at the rear portion of the earth-moving machinery. May be fitted higher if the design of the bodywork makes it impossible to keep within 1 500 mm. | | | | | | | | | |
| b May be reduced to 10° if the design of the bodywork makes it necessary. | | | | | | | | | |
| c The reversing lamp shall be illuminated when the operator has actuated the control for the reverse direction and if the device which controls the starting or stopping of the engine is in a position such that operation of the engine is possible. The reversing lamp shall not be illuminated if either of the above conditions is not satisfied. The reversing lamp shall not be illuminated when the direction control is in the neutral or forward direction positions. | | | | | | | | | |

E.5 Data sheet

E.5.1 Direction indicator lamp: a lamp used to indicate to other road-users and other participants on the work site that the operator/driver of the earth-moving machinery intends to change direction to the right or to the left.

E.5.1.1 Colour of light: amber.

E.5.1.2 Alignment: the installation direction laid down by the lamp manufacturer shall be observed.

E.5.1.3 Flashing frequency: 1,5 Hz ± 0,5 Hz (90 ± 30) times/min.

E.5.1.4 Types of direction-indicator lamps:

Categories 1, 1a, 1b: front direction-indicator lamps.

Categories 2a, 2b: rear direction-indicator lamps.

Category 3: front-side direction-indicator lamp (not combined with any other category).

Category 4: front-side direction-indicator lamp (to be combined with Category 2).

Category 5: supplementary side direction-indicator lamp (to be combined with Categories 1 and 2 — all three together).

| Application | Arrangement ^a | Installation outline | Category |
|--|--------------------------|--|---------------|
| Earth-moving machinery with a maximum base machine length of 4,60 m and a maximum lateral distance between the outer edges of the illuminating surfaces of 1,50 m. | A [Figure E.5 a)] | Two front-side direction-indicator lamps | 3 |
| Earth-moving machinery with a front-mounted structure, linkage etc. which prevents the use of arrangements A, C and D. | B [Figure E.5 b)] | Two front-side direction-indicator lamps | 4 |
| | | Two rear direction-indicator lamps | 2a or 2b |
| Any earth-moving machinery | C [Figure E.5 c)] | Two front direction-indicator lamps | 1 or 1a or 1b |
| | | Two rear direction-indicator lamps | 2a or 2b |
| | | Two side direction-indicator lamps (supplementary) | 5 |
| Any earth-moving machinery | D [Figure E.5 d)] | Two front direction-indicator lamps | 1 or 1a or 1b |
| | | Two rear direction indicator lamps | 2a or 2b |

^a Accepted combinations are presented in Figure E.5 a) to d).

E.5.1.5 General requirements/explanations: these are as follows.

- a) Direction-indicator lamps shall illuminate independently of other lamps. All direction-indicator lamps on one side of the machine shall be switched on and off by means of one control and shall flash in phase.
- b) Close circuit tell-tale is mandatory for front and rear direction-indicator lamps. It shall be optical (green flashing) or auditory (clearly audible) or both. For Lighting Group II machines, an operational tell-tale could be required for front and rear lamps.
- c) Operation of the light-signal control shall be followed < 1 s by the appearance of the light and $< 1,5$ s by its first extinction. The illuminating surface of front direction-indicator lamps, Category 1, shall be > 40 mm, Category 1a < 40 but > 20 mm, and Category 1b < 20 mm from the illuminating surface of the dipped/lower beam headlamp.
- d) When the hazard warning lamp control is actuated, the direction-indicator lamps need not function in the direction-indicator mode.
- e) On Lighting Group II machines, where the distance between the outer edges of the illuminating surfaces of the front and rear direction-indicator lamps is more than 6 m, supplementary direction-indicator lamps, Category 5, shall be fitted on both sides, preferably to the first third of the total length of the machine [see Figure E.5 c)].

E.5.1.6 Configuration: the direction-indicator lamp

- a) may be grouped with one or more lamps,
- b) may only be combined with
 - front direction-indicator lamps (Categories 1, 1a, 1b),
 - rear direction-indicator lamps (Categories 1a, 2b), and
 - supplementary side direction-indicator lamps (Category 5), and
- c) may only be reciprocally incorporated with supplementary side direction-indicator lamps (Category 5).

E.5.1.7 Minimum angle of visibility for direction-indicators

E.5.1.7.1 Arrangements A and B: geometrical visibility horizontal (Data Sheets E.5.2 to E.5.6). See Figure E.5 a) and b).

E.5.1.7.2 Arrangements C and D: see Figure E.5 c) and d).

Dimensions in metres

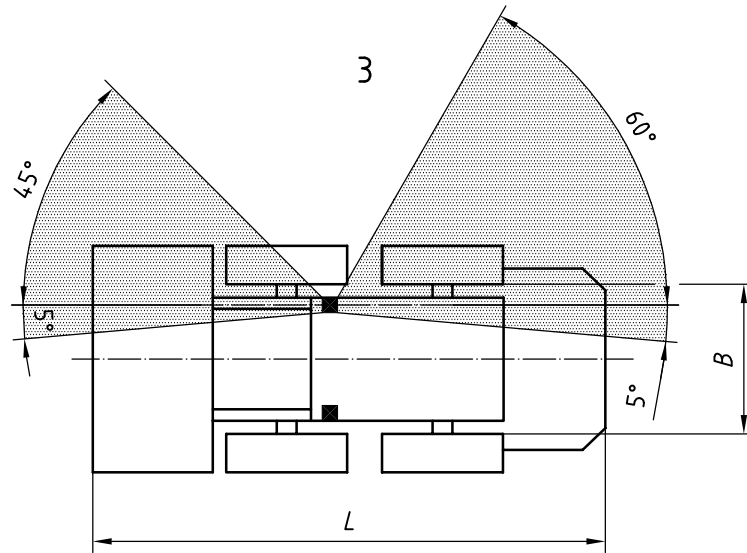

$L \leq 4,6$
 $B \leq 1,6$

a) Arrangement A

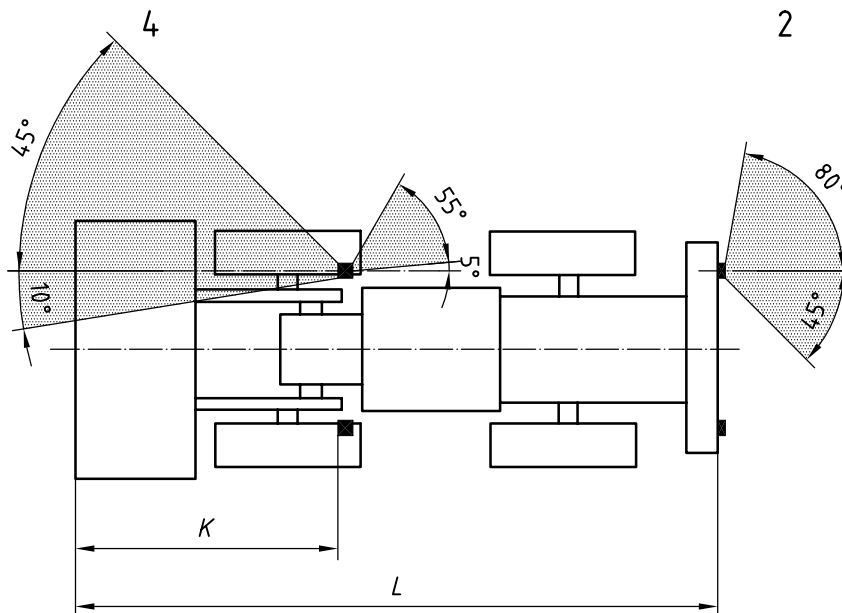

$K \leq L/2^a$

b) Arrangement B

Figure E.5

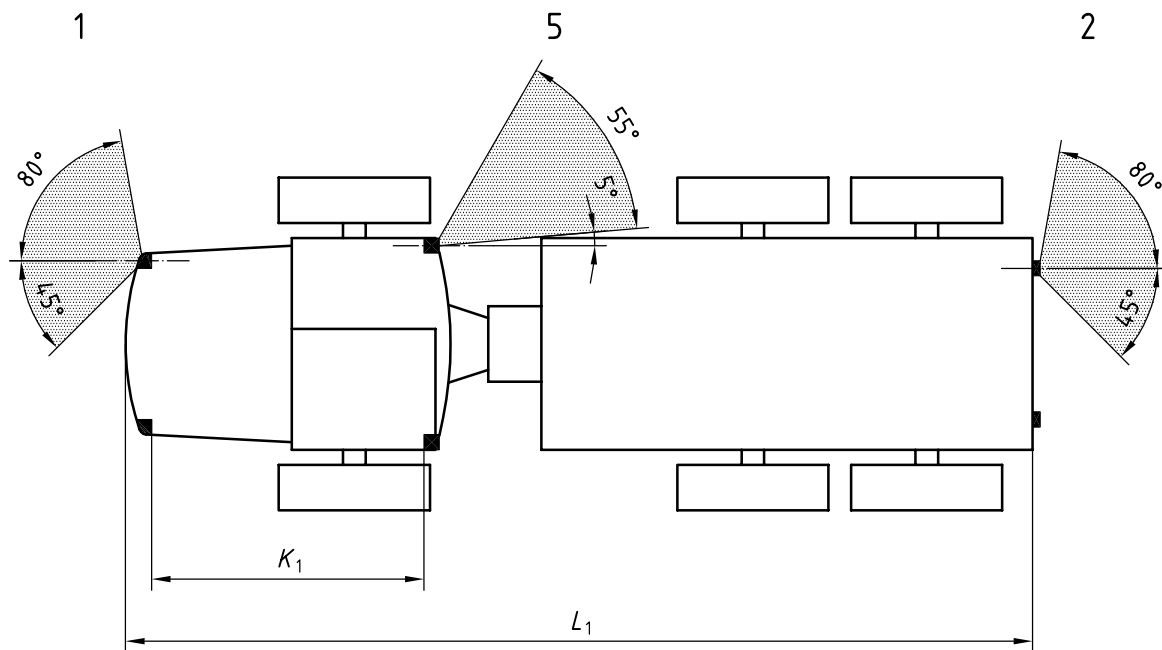

$$K_1 \leq L_1/3^b$$

c) Arrangement C

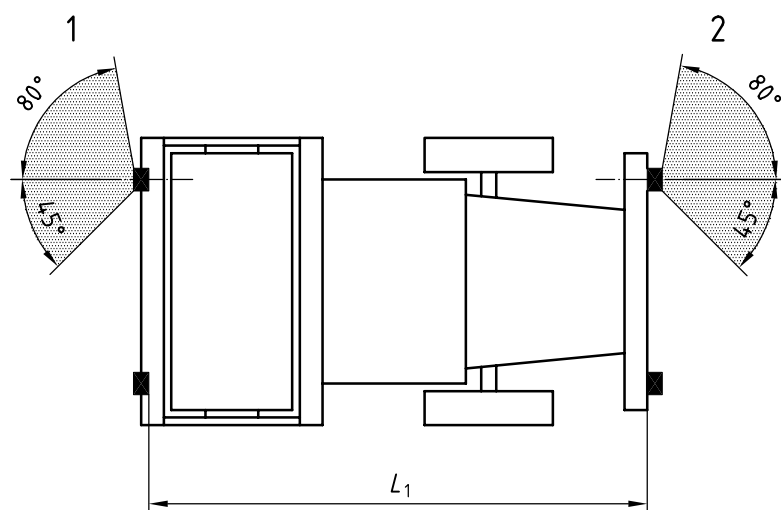

$$L_1 \leq 6$$

d) Arrangement D

Key

L overall length of base machine, including front and rear equipment ^c

L_1 distance between the edges of the illumination surface of the lamps

K distance from the front of the machine to the edge of the illuminating surface

K_1 distance between the edges of the illuminating surface

B distance between the outer edges of the light-emitting surface

1 Category 1

2 Category 2

3 Category 3

4 Category 4

5 Category 5

^a The direction-indicator lamp shall be installed as close as possible towards the front.

^b If $K_1 \leq 1/3 L$ is impossible, the direction-indicator lamp shall be installed as close as possible towards the front.

^c See, for example, ISO 7131, ISO 7133.

Figure E.5 (continued)

E.5.2 Data sheet

E.5.2.1 Front direction-indicator lamp: (see Figure E.6). Categories 1, 1a and 1b (see E.5.1.4).

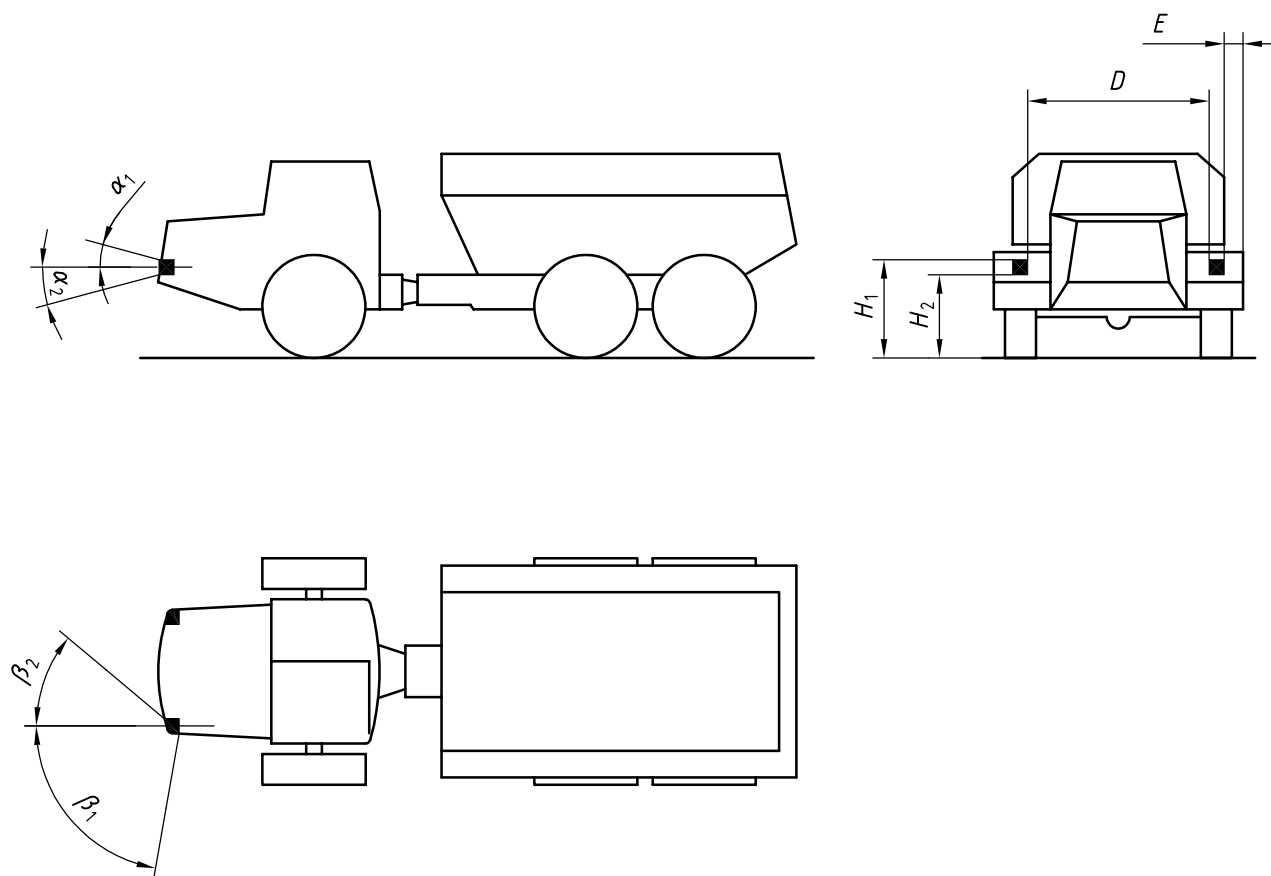

Figure E.6

E.5.2.2 Configuration: in Arrangement C, together with direction-indicator lamps Categories 2 and 5, and in Arrangement D, together with direction-indicator lamp Category 2 (see E.5.1.7.2).

E.5.2.3 Requirements for front direction indicator lamp: Categories 1, 1a and 1b (see E.5.1.4).

| Lighting groups (see Annex A) | I | | | II | | | III | | | |
|---|-----|---------------------------|----------------|-----------------|----------------|----------------|-----|--------------------------|----------------|--|
| | A | B | C | A | B | C | A | B | C | |
| Application to machines | N/A | O ^a | S ^a | S ^a | S ^a | S ^a | N/A | O ^a | S ^a | |
| Number | N/A | Two or four ^b | | | | | N/A | Two or four ^b | | |
| Dimensions, in mm | | | | | | | | | | |
| H_1 | N/A | $\leq 1\,500^c$ | | $\leq 1\,500^d$ | | | N/A | $\leq 1\,500^c$ | | |
| H_2 | N/A | > 400 | | | | | N/A | > 600 | | |
| E | N/A | $\leq 400^e$ | | ≤ 400 | | | N/A | $\leq 400^e$ | | |
| D | N/A | $> 500^f$ | | | | | N/A | $> 500^f$ | | |
| Geometric visibility, min. angles | | | | | | | | | | |
| α_1 | N/A | 15° latitude | | | | | N/A | 15° latitude | | |
| α_2 | N/A | 15° latitude ^g | | | | | N/A | 15° latitude | | |
| β_1 | N/A | 80° ^h | | | | | N/A | 80° ^{h, i} | | |
| β_2 | N/A | 45° ^h | | | | | N/A | 45° ^{h, i} | | |
| Electrical connections | N/A | See E.5.1.5 | | | | | N/A | See E.5.1.5 | | |
| Tell-tale | N/A | See E.5.1.5 | | | | | N/A | See E.5.1.5 | | |
| Other requirements | N/A | See E.5.1.5 | | | | | N/A | See E.5.1.5 | | |
| Exceptions: | | | | | | | | | | |
| a Not applicable to steel-tracked or steel-pad-foot wheeled machines. | | | | | | | | | | |
| b Four allowed if two don't comply with angles β_1 (outward) and β_2 (inward). If four, one pair shall meet the requirement of angle β_1 and the other, β_2 . | | | | | | | | | | |
| c May be fitted higher if the design of the bodywork makes it impossible to meet the requirement of $\leq 1\,500$ m. | | | | | | | | | | |
| d May be fitted higher if the design of the bodywork makes it impossible to meet the requirement of $\leq 1\,500$ m; maximum height shall be 2 100 m. | | | | | | | | | | |
| e May be > 400 mm if the design of the bodywork makes it impossible to meet the requirement of ≤ 400 mm. | | | | | | | | | | |
| f May be < 500 mm if the design of the bodywork makes it impossible to meet the requirement of > 500 mm. | | | | | | | | | | |
| g May be reduced to 5° bodywork makes it necessary. | | | | | | | | | | |
| h If two pairs, the angle of one pair shall be 80° and that of the other, 45°. | | | | | | | | | | |
| i May be reduced if the design of the bodywork makes 80° or 45° impossible. | | | | | | | | | | |

E.5.3 Data sheet

E.5.3.1 Rear direction-indicator lamp: (see Figure E.7). Categories 2a and 2b.

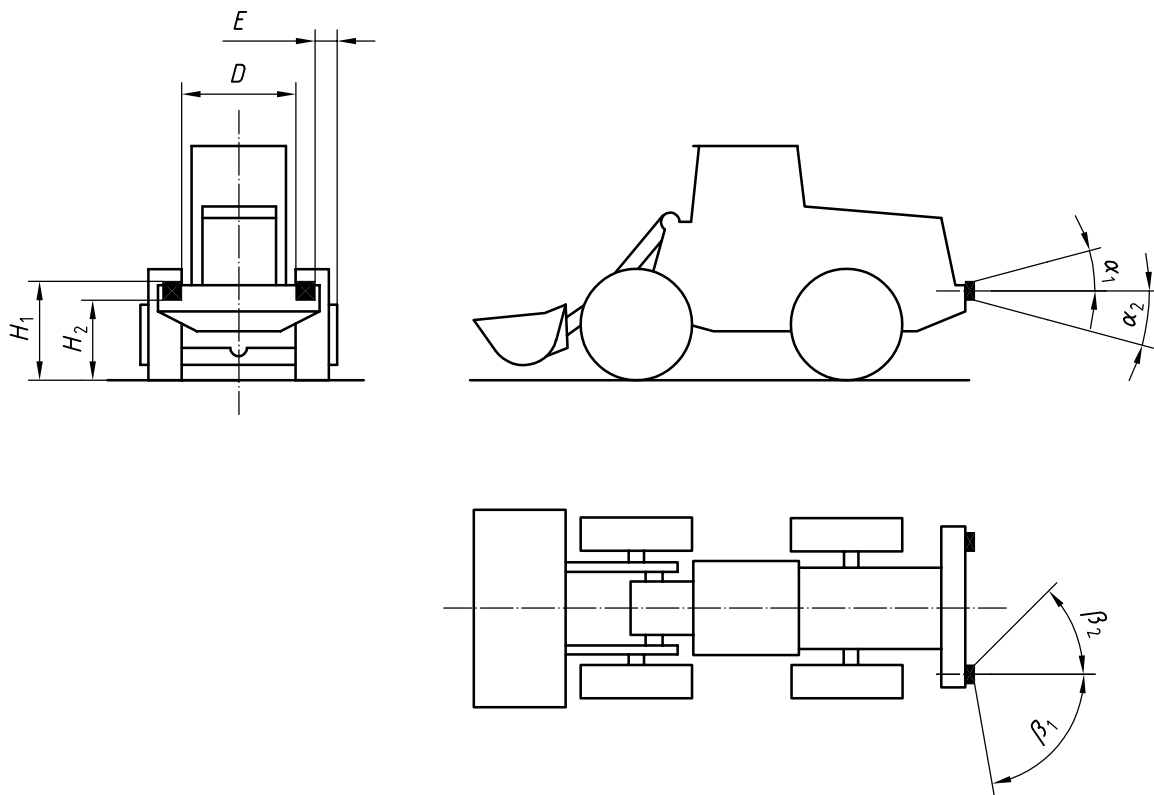

Figure E.7

E.5.3.2 Configuration: in Arrangement B, together with direction-indicator lamp Category 4 (see E.5.1.7.1); in Arrangement C, together with direction-indicator lamps Categories 1 and 5; in Arrangement D, together with direction-indicator lamp Category 2 (see E.5.1.7.2).

E.5.3.3 Requirements for rear-direction indicator lamp: Categories 2a and 2b (see E.5.1.4).

| Lighting groups (see Annex A) | I | | | II | | | III | | | |
|---|-----|---------------------------|----------------|-----------------|----------------|----------------|-----|---------------------------|----------------|--|
| | A | B | C | A | B | C | A | B | C | |
| Application to machines | N/A | O ^a | S ^a | S ^a | S ^a | S ^a | N/A | O ^a | S ^a | |
| Number | N/A | Two or four ^b | | | | | N/A | Two or four ^b | | |
| Dimensions, in mm | | | | | | | | | | |
| H_1 | N/A | $\leq 1\,500^c$ | | $\leq 1\,500^d$ | | | N/A | $\leq 1\,500^c$ | | |
| H_2 | N/A | > 400 | | | | | N/A | > 600 | | |
| E | N/A | $\leq 400^e$ | | ≤ 400 | | | N/A | $\leq 400^e$ | | |
| D | N/A | $> 500^f$ | | | | | N/A | $> 500^f$ | | |
| Geometric visibility, min. angles | | | | | | | | | | |
| α_1 | N/A | 15° latitude ^g | | | | | N/A | 15° latitude ^g | | |
| α_2 | N/A | 15° latitude ^h | | | | | N/A | 15° latitude ^h | | |
| β_1 | N/A | 80° ⁱ | | | | | N/A | 80° ^{i, j} | | |
| β_2 | N/A | 45° ⁱ | | | | | N/A | 45° ^{i, j} | | |
| Electrical connections | N/A | See E.5.1.5 | | | | | N/A | See E.5.1.5 | | |
| Tell-tale | N/A | See E.5.1.5 | | | | | N/A | See E.5.1.5 | | |
| Other requirements | N/A | See E.5.1.5 | | | | | N/A | See E.5.1.5 | | |
| Exceptions: | | | | | | | | | | |
| a Not applicable to steel-tracked or steel-pad-foot wheeled machines. | | | | | | | | | | |
| b Four shall be used if two do not meet the requirements for comply Angle β_1 (outward) and β_2 (inward) — one pair shall meet the requirement of β_1 and the other, that for β_2 . | | | | | | | | | | |
| c May be fitted higher if the design of the bodywork makes it impossible to meet the requirement of $\leq 1\,500$ mm. | | | | | | | | | | |
| d May be fitted higher if the design of the bodywork makes it impossible to meet the requirement of $\leq 1\,500$ mm: maximum height shall be 2 100 mm. | | | | | | | | | | |
| e May be > 400 mm if the design of the bodywork makes it impossible to meet the requirement of ≤ 400 mm. | | | | | | | | | | |
| f May be reduced if the design of the bodywork makes it impossible to meet the requirement of > 500 mm, for example, on rear-dump dumper. | | | | | | | | | | |
| g May be reduced to 10° if the design of the bodywork makes it necessary. | | | | | | | | | | |
| h May be reduced to 5° if the design of the bodywork makes it necessary. | | | | | | | | | | |
| i If two pairs, the angle of one pair shall be 80° and that of the other, 45°. | | | | | | | | | | |
| j May be reduced if the design of the bodywork makes it 80° or 45° impossible, for example, on a machine with rear-mounted working equipment or rear-dump dumper. | | | | | | | | | | |

E.5.4 Data sheet

E.5.4.1 Front side direction-indicator lamp: (see Figure E.8) Category 3b.

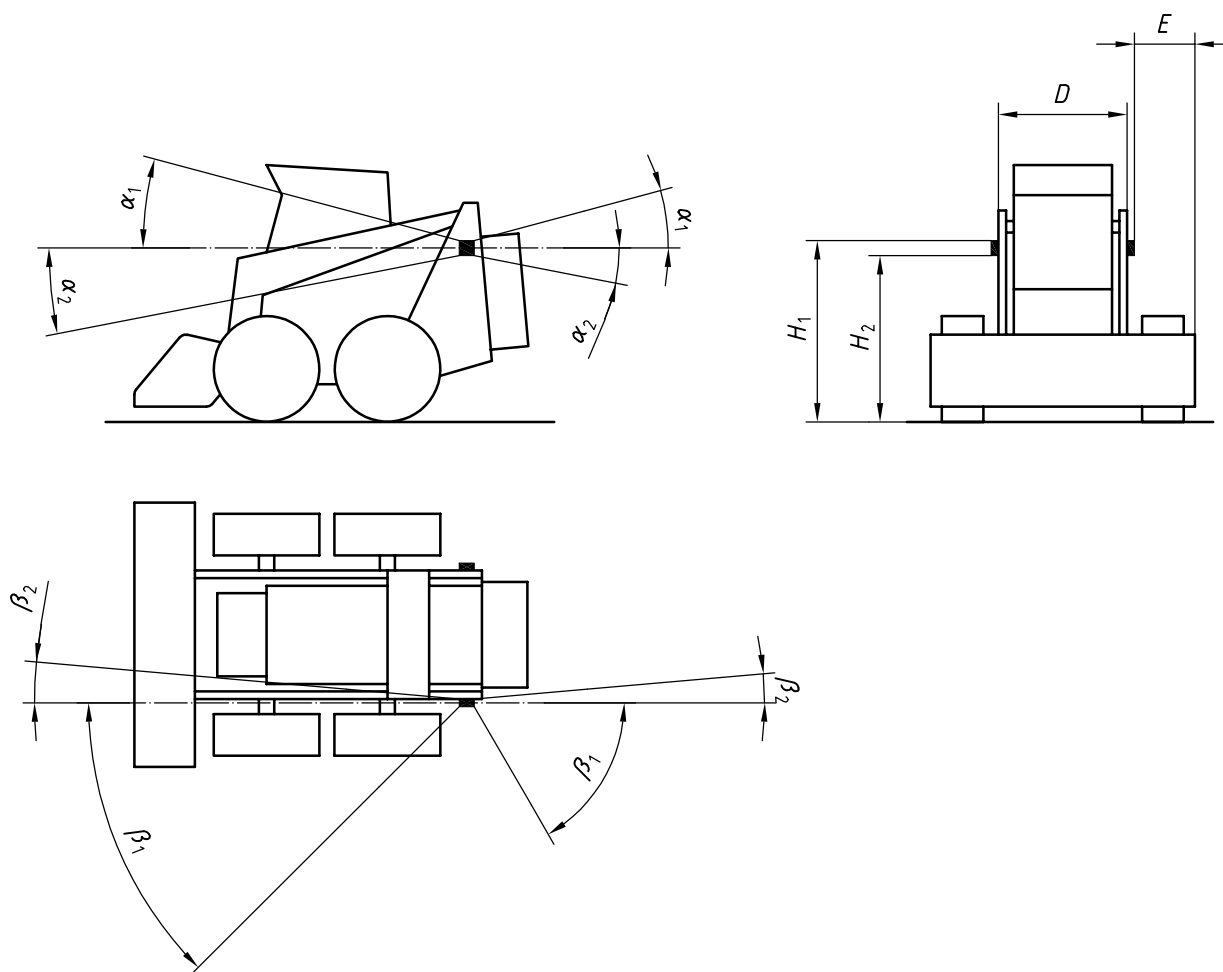

Figure E.8

E.5.4.2 Configuration: in Arrangement A (see E.5.1.7.1).

E.5.4.3 Requirements for front side direction-indicator lamp: Category 3 (see E.5.1.4).

| Lighting groups (see Annex A) | I | | | II | | | III | | |
|---|------------------|----------------|----------------|-----------------|----------------|----------------|-----|--------------------------|----------------|
| | A | B | C | A | B | C | A | B | C |
| Application to machines | O ^a | O ^a | O ^a | S ^a | S ^a | S ^a | N/A | S ^a | S ^a |
| Number | Two ^b | | | | | | N/A | Two ^b | |
| Dimensions, in mm | | | | | | | | | |
| H_1 | $\leq 1\,500^c$ | | | $\leq 1\,500^d$ | | | N/A | $\leq 1\,500^c$ | |
| H_2 | > 400 | | | | | | N/A | > 600 | |
| E | N/A | | | | | | | | |
| D | N/A | | | | | | | | |
| Geometric visibility, min. angles | | | | | | | | | |
| α_1 | 15° latitude | | | | | | N/A | 15° latitude | |
| α_2 | 10° latitude | | | | | | N/A | 10° latitude | |
| β_1 | 45° front | | | | | | N/A | 45° front | |
| | 60° rear | | | | | | N/A | 60° rear | |
| β_2 | 5° front | | | | | | N/A | 5° front ^e | |
| | 5° rear | | | | | | N/A | 5° rear ^e | |
| Electrical connections | See E.5.1.5 | | | | | | N/A | See E.5.1.5 | |
| Tell-tale | See E.5.1.5 | | | | | | N/A | See E.5.1.5 | |
| Other requirements | See E.5.1.5 | | | | | | N/A | See E.5.1.5 ^f | |
| Exceptions: | | | | | | | | | |
| a Not applicable to steel-tracked or steel-pad-foot wheeled machines. | | | | | | | | | |
| b Direction-indicator lamps of Category 3 may not be combined with any other direction-indicator lamp (see E.5.1.7.1, Arrangement A). If the Category 3 lamp does not fulfil the geometric visibility (owing to equipment or attachment), Arrangement D (see E.5.1.7.2) shall be used. | | | | | | | | | |
| c May be fitted higher if the design of the bodywork makes it impossible to meet the requirement of $\leq 1\,500$ mm. | | | | | | | | | |
| d May be fitted higher if the design of the bodywork makes it impossible to meet the requirement of $\leq 1\,500$ mm: maximum height shall be 2 100 mm. | | | | | | | | | |
| e May be reduced to 2° if the design of the bodywork makes it necessary. | | | | | | | | | |
| f Direction-indicator lamps of Category 3 may only be used on earth-moving machines whose overall length does not exceed 4,60 m and where the distance between the outlines of the illuminating surfaces of the front and the rear indicators is $\leq 1,60$ m. See E.5.1.7.1, Arrangement A. | | | | | | | | | |

E.5.5 Data sheet

E.5.5.1 Front side direction-indicator lamp: (see Figure E.9) Category 4.

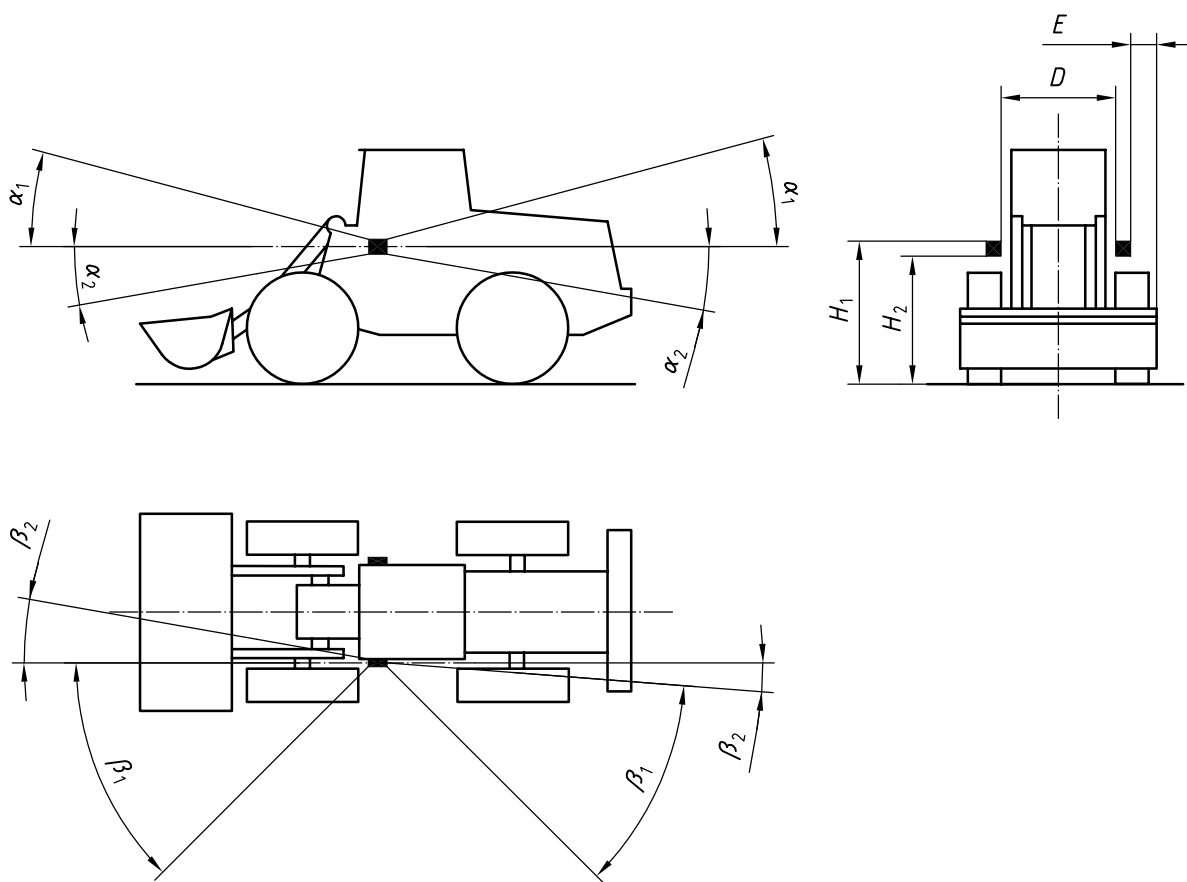

Figure E.9

E.5.5.2 Configuration: in Arrangement B, it shall be combined with direction-indicator lamp, Category 2 (see E.5.1.7.1).

E.5.5.3 Requirements for front side direction-indicator lamp: Category 4 (see E.5.1.4).

| Lighting groups (see Annex A) | I | | | II | | | III | | |
|---|-----|------------------|----------------|-----------------|------------------------|----------------|-----|-----------------|------------------------|
| | A | B | C | A | B | C | A | B | C |
| Application to machines | N/A | O ^a | S ^a | S ^a | S ^a | S ^a | N/A | O ^a | S ^a |
| Number | N/A | Two ^b | | | Two ^b | | | N/A | Two ^b |
| Dimensions, in mm | | | | | | | | | |
| H_1 | N/A | $\leq 1\,500^c$ | | $\leq 1\,500^d$ | | | N/A | $\leq 1\,500^c$ | |
| H_2 | N/A | > 400 | | | > 400 | | | N/A | > 600 |
| E | N/A | $\leq 400^e$ | | ≤ 400 | | | N/A | $\leq 400^e$ | |
| D | N/A | > 500 | | | > 500 | | | N/A | > 500 |
| K | N/A | f | | | f | | | N/A | f |
| Geometric visibility, min. angles | | | | | | | | | |
| α_1 | N/A | 15° latitude | | | 15° latitude | | | N/A | 15° latitude |
| α_2 | N/A | 10° latitude | | | 10° latitude | | | N/A | 10° latitude |
| β_1 | N/A | 45° front | | | 45° front | | | N/A | 45° front |
| | n/A | 55° rear | | | 55° rear | | | N/A | 55° rear |
| β_2 | N/A | 10° front | | | 10° front ^e | | | N/A | 10° front ^e |
| | N/A | - 5° rear | | | - 5° rear ^e | | | N/A | - 5° rear ^e |
| Electrical connections | N/A | See E.5.1.5 | | | See E.5.1.5 | | | N/A | See E.5.1.5 |
| Tell-tale | N/A | See E.5.1.5 | | | See E.5.1.5 | | | N/A | See E.5.1.5 |
| Other requirements | N/A | See E.5.1.5 | | | See E.5.1.5 | | | N/A | See E.5.1.5 |
| Exceptions: | | | | | | | | | |
| a Not applicable to steel-tracked or steel-pad-foot wheeled machines. | | | | | | | | | |
| b Side direction-indicator lamps of Category 4 may only be used in combination with rear direction-indicator lamps of Category 2. See E.5.1.7.1, Arrangement B. | | | | | | | | | |
| c May be fitted higher if the design of the bodywork makes it impossible to meet the requirement of $\leq 1\,500$ mm. | | | | | | | | | |
| d May be fitted higher if the design of the bodywork makes it impossible to meet the requirement of $\leq 1\,500$ mm: maximum height shall be 2 100 mm. | | | | | | | | | |
| e May be > 400 mm if the design of the bodywork makes it impossible to meet the requirement of ≤ 400 mm. | | | | | | | | | |
| f See E.5.1.7.1. | | | | | | | | | |

E.5.6 Data sheet

E.5.6.1 Supplementary side direction-indicator lamp: (see Figure E.10) Category 5.

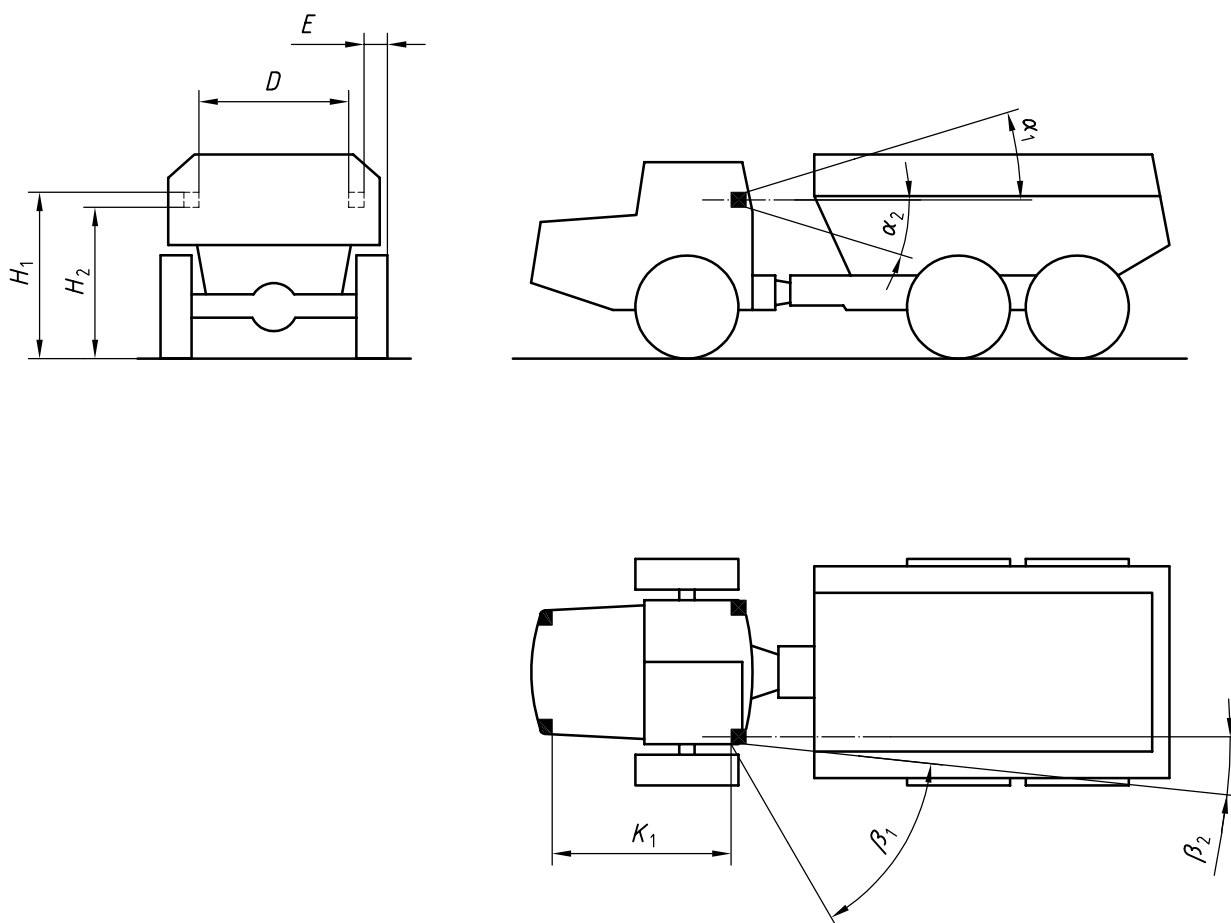

Figure E.10

E.5.6.2 Configuration: in Arrangement C, it shall be combined with direction-indicator lamps, Categories 1 and 2 (see E.5.1.7.2).

E.5.6.3 Requirements for supplementary side direction-indicator lamp: Category 5 (see E.5.1.4).

| Lighting groups (see Annex A) | I | | | II | | | III | | |
|--|-----|---------------------------|---|-----------------|---------------------------|---|-----|-----------------|---------------------------|
| | A | B | C | A | B | C | A | B | C |
| Application to machines | N/A | O | O | S | S | S | N/A | O | O |
| Number | N/A | Two | | | Two | | | N/A | Two |
| Dimensions, in mm | | | | | | | | | |
| H_1 | N/A | $\leq 1\,500^a$ | | $\leq 1\,500^b$ | | | N/A | $\leq 1\,500^a$ | |
| H_2 | N/A | > 500 | | | > 500 | | | N/A | > 800 |
| E | N/A | | | | | | | | |
| D | N/A | | | | | | | | |
| K | N/A | c | | | c | | | N/A | c |
| Geometric visibility, min. angles | | | | | | | | | |
| α_1 | N/A | 15° latitude | | | 15° latitude | | | N/A | 15° latitude |
| α_2 | N/A | 15° latitude ^d | | | 15° latitude ^d | | | N/A | 15° latitude ^d |
| β_1 | N/A | 55° rear | | | 55° rear | | | N/A | 55° rear |
| β_2 | N/A | – 5° rear | | | – 5° rear | | | N/A | – 5° rear |
| Electrical connections | N/A | See E.5.1.5 | | | See E.5.1.5 | | | N/A | See E.5.1.5 |
| Tell-tale | N/A | See E.5.1.5 | | | See E.5.1.5 | | | N/A | See E.5.1.5 |
| Other requirements | N/A | See E.5.1.5 ^e | | | See E.5.1.5 ^e | | | N/A | See E.5.1.5 ^e |
| Exceptions: | | | | | | | | | |
| a May be fitted higher if the design of the bodywork makes it impossible to meet the requirement of $\leq 1\,500$ mm. | | | | | | | | | |
| b May be fitted higher if the design of the bodywork makes it impossible to meet the requirement of $\leq 1\,500$ mm: maximum height shall be 2 100 mm. | | | | | | | | | |
| c See E.5.4. | | | | | | | | | |
| d May be reduced to 5° if the design of the bodywork makes it necessary. | | | | | | | | | |
| e Supplementary side direction-indicator lamps of Category 5 may only be used in combination with direction-indicator lamps of Categories 1 and 2 on earth-moving machines with an overall length $L > 6$ m (all three in the same arrangement). See E.5.1.7.2, Arrangement C. | | | | | | | | | |

E.6 Data sheet

E.6.1 Hazard warning signal: the simultaneous operation of all direction-indicator lamps of an earth-moving machine to indicate the presence of an earth-moving machine which is unable to continue its operation, or is operating at a reduced speed, and thus presents a hazard to other on-road and off-road users.

See Figure E.11.

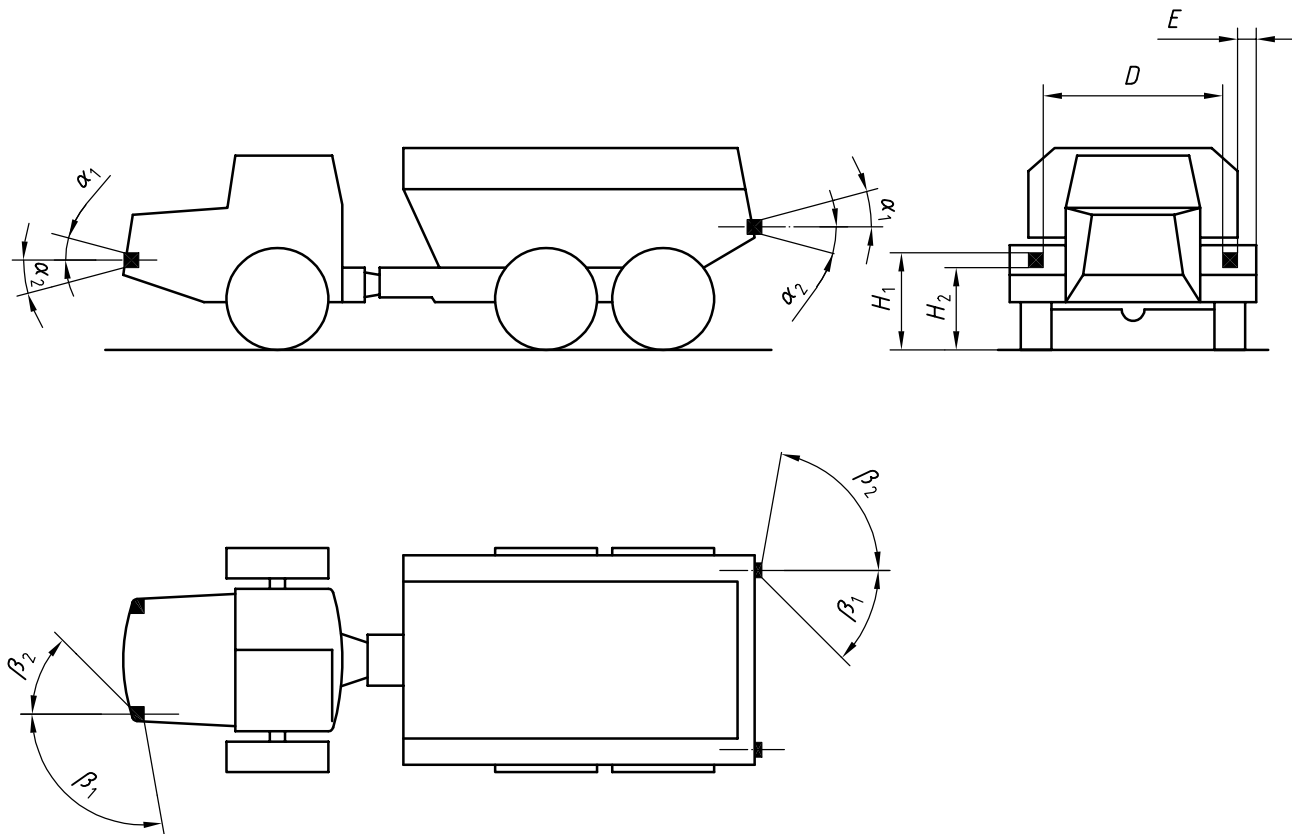

Figure E.11

E.6.2 Configuration: Arrangement — see E.5.

E.6.3 Requirements for hazard warning signal

| Lighting groups (see Annex A) | I | | | II | | | III | | |
|--|-----|----------------|----------------|----------------|----------------|----------------|-----|----------------|----------------|
| | A | B | C | A | B | C | A | B | C |
| Application to machines | N/A | O ^a | S ^a | S ^a | S ^a | S ^a | N/A | O ^a | S ^a |
| Number | N/A | b | | | b | | | N/A | b |
| Dimensions, mm | N/A | b | | | b | | | N/A | b |
| Geometric visibility, min. angles | N/A | b | | | b | | | N/A | b |
| Electrical connections | N/A | c | | | c | | | N/A | c |
| Tell-tale | N/A | d | | | d | | | N/A | d |
| Other requirements | N/A | e | | | e | | | N/A | e |
| Exceptions: | | | | | | | | | |
| a Not applicable to steel-tracked or steel-pad-foot wheeled machines. | | | | | | | | | |
| b Equivalent to direction-indicator lamps (see E.5.2 to E.5.6). | | | | | | | | | |
| c Shall be operated by separate control. All direction-indicator lamps shall function simultaneously. | | | | | | | | | |
| d Circuit-closed tell-tale is required. Tell-tale light shall be flashing and may be the simultaneous operation of the tell-tale(s) of the direction-indicator lamps (see E.5.1.5). | | | | | | | | | |
| e Hazard warning signal may be used on work sites with heavy traffic, e.g. rollers moving backwards and forwards or loaders in work-cycles. The hazard warning signal lamps shall not be connected with the switch-off key for the engine. | | | | | | | | | |

E.7 Data sheet

E.7.1 Stop lamp: the lamp used to indicate to road-users and other exposed persons to the rear of the earth-moving machine, that the operator has actuated the service brake control. See Figure E.12.

E.7.1.1 Colour of light: red.

E.7.1.2 Alignment: towards the rear.

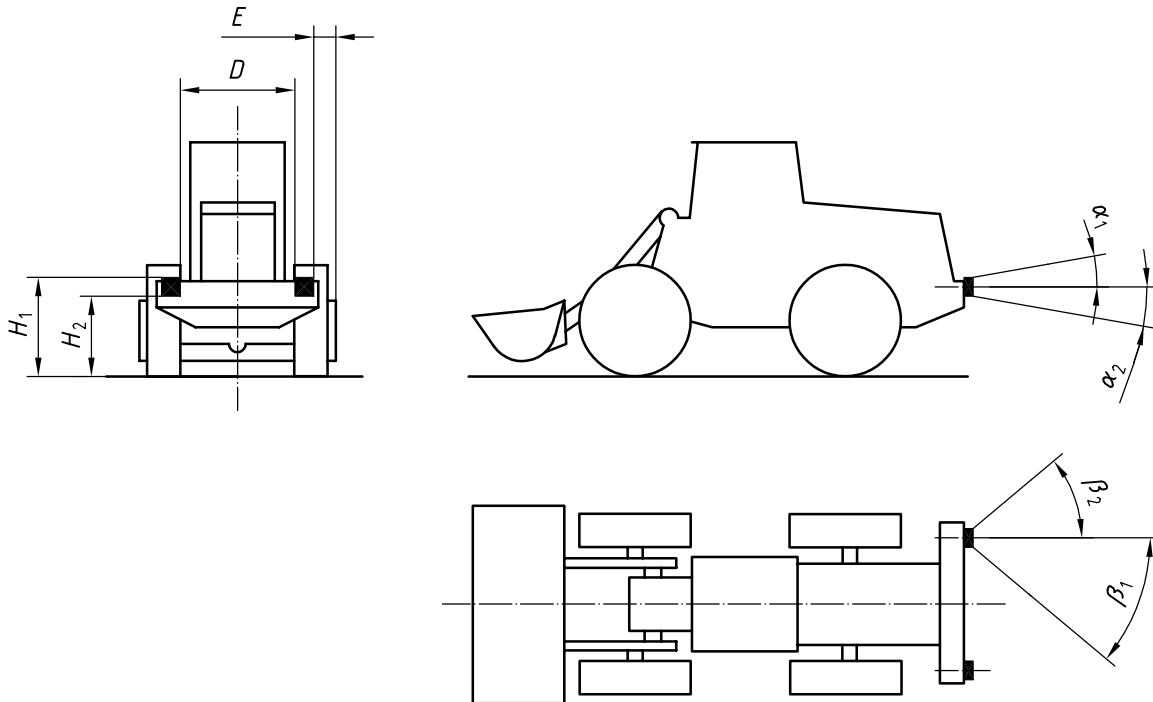

Figure E.12

E.7.1.3 Configuration: the stop lamp

- may be grouped with one or more other rear lamps,
- shall not be combined with another lamp, and
- shall not be reciprocally incorporated with the rear-position lamp.

E.7.2 Requirements for stop lamp

| Lighting groups (see Annex A) | I | | | II | | | III | | |
|---|-----|------------------|----------------|-----------------|----------------|----------------|-----|------------------|----------------|
| | A | B | C | A | B | C | A | B | C |
| Application to machines | N/A | O | S ^b | O | S ^a | S ^b | N/A | O | S ^b |
| Number | N/A | Two ^b | | Two | | | N/A | Two ^b | |
| Dimensions, in mm | | | | | | | | | |
| H_1 | N/A | $\leq 1\,500^c$ | | $\leq 1\,500^d$ | | | N/A | $\leq 1\,500^c$ | |
| H_2 | N/A | > 400 | | | | | N/A | > 600 | |
| E | N/A | | | | | | | | |
| D | N/A | $> 500^e$ | | | | | N/A | $> 500^e$ | |
| Geometric visibility, min. angles | | | | | | | | | |
| α_1 | N/A | 15° | | | | | N/A | 10° | |
| α_2 | N/A | 15°^f | | | | | N/A | 15°^f | |
| β_1 | N/A | 45° | | | | | N/A | 30°^g | |
| β_2 | N/A | 45° | | | | | N/A | 30°^g | |
| Electrical connections | N/A | h | | | | | N/A | h | |
| Tell-tale | N/A | i | | | | | N/A | i | |
| Other requirements | N/A | j | | | | | N/A | j | |
| Exceptions: | | | | | | | | | |
| a Not applicable to hydrostatic-driven machines with a designed speed of ≤ 20 km/h and without a brake pedal. | | | | | | | | | |
| b Not applicable to steel-tracked and steel-pad-foot wheeled machines. | | | | | | | | | |
| c May be fitted higher, if the design of the bodywork makes it impossible to meet the requirement of $\leq 1\,500$ mm. | | | | | | | | | |
| d May be fitted higher if the design of the bodywork makes it impossible to meet the requirement of $\leq 1\,500$ mm: maximum height shall be 2 100 mm. | | | | | | | | | |
| e May be reduced if the design of the bodywork makes it impossible to meet the requirement of > 500 mm, e.g. on rear dump dumper. | | | | | | | | | |
| f May be reduced to 5° depending on the structure of the earth-moving machine. | | | | | | | | | |
| g On machines with rear-mounted equipment and dumpers with a rear dump which are not subject to road travel, the angle may be reduced if the design of the bodywork makes it impossible to meet the requirement of 30° . | | | | | | | | | |
| h Actuation of the service brake control shall close the electrical circuit for the stop lamp. | | | | | | | | | |
| i If any, it should be a non-flashing light which comes on in the event of the malfunctioning of the stop lamps. | | | | | | | | | |
| j The luminous intensity of the stop lamp shall be markedly brighter than that of the rear-position lamp. | | | | | | | | | |

E.8 Data sheet

E.8.1 Rear registration-plate lamp: the device used to illuminate the space intended to accommodate the rear registration-plate; it may consist of different optical elements. See Figure E.13.

E.8.1.1 Colour of light: white.

E.8.1.2 Alignment: towards the rear.

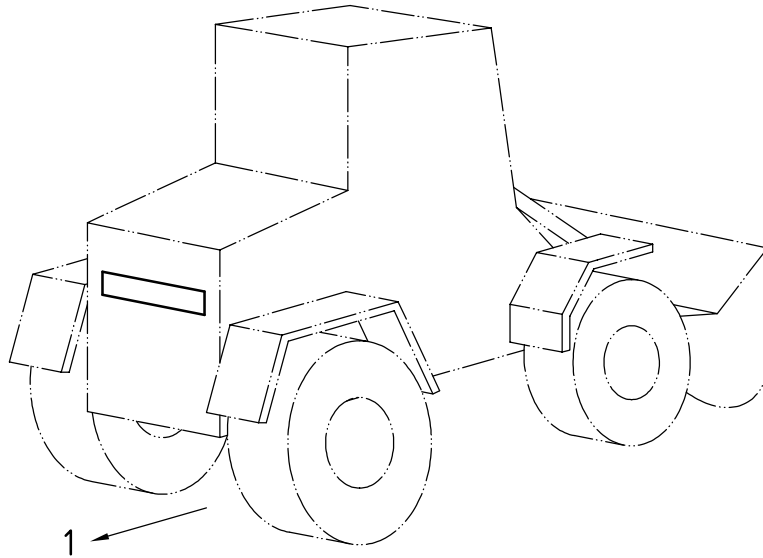

Key

1 rear

Figure E.13

E.8.1.3 Configuration: the rear registration plate lamp

- a) may be grouped with one or more rear lamps,
- b) may be combined with rear-position lamps, but
- c) shall not be reciprocally incorporated with another lamp.

E.8.2 Requirements for rear registration-plate lamp

| Lighting groups (see Annex A) | I | | | II | | | III | | |
|--|-----|---|---|----------------|---|---|-----|---|---|
| | A | B | C | A | B | C | A | B | C |
| Application to machines | N/A | | | S ^a | | | N/A | | |
| Number | N/A | | | b | | | N/A | | |
| Dimensions, in mm | | | | | | | | | |
| H_1 | N/A | | | b | | | N/A | | |
| H_2 | N/A | | | b | | | N/A | | |
| E | | | | b | | | N/A | | |
| D | N/A | | | b | | | N/A | | |
| Geometric visibility, min. angles | | | | | | | | | |
| α_1 | N/A | | | b | | | N/A | | |
| α_2 | N/A | | | b | | | N/A | | |
| β_1 | N/A | | | b | | | N/A | | |
| β_2 | N/A | | | b | | | N/A | | |
| Electrical connections | N/A | | | c | | | N/A | | |
| Tell-tale | N/A | | | | | | | | |
| Other requirements | N/A | | | d | | | N/A | | |
| Exceptions: | | | | | | | | | |
| <p>a Only valid on earth-moving machines subject to road approval and those which, according to national legislation, must be registered and equipped with a rear registration-plate lamp.</p> <p>b Such that device is capable of illuminating the space intended to accommodate the rear registration-plate.</p> <p>c The rear registration-plate lamp shall be switched on together with the rear-position lamps.</p> <p>d The light shall not dazzle and shall not be directly visible towards the rear.</p> | | | | | | | | | |

E.9 Data sheet

E.9.1 Front position lamp: the lamp used to indicate the presence and the width of the earth-moving machine when viewed from the front. See Figure E.14.

E.9.1.1 Colour of light: white. Where national requirements differ from the requirement of this International Standard, the national requirements may be applied.

E.9.1.2 Alignment: towards the front.

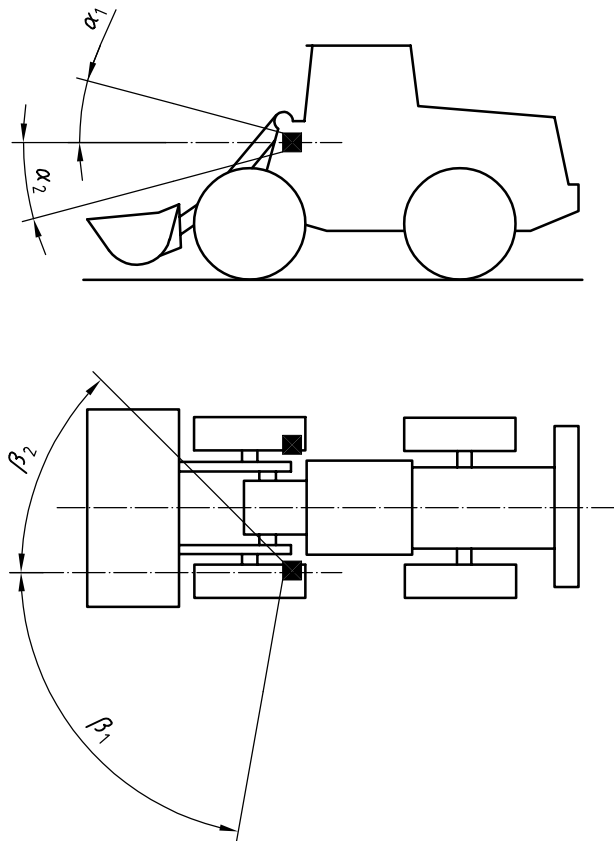

Figure E.14

E.9.1.3 Configuration: the front position lamp

- a) may be grouped with any other front lamp,
- b) shall not be combined with any other lamps, but
- c) may be reciprocally incorporated with any other front lamp.

E.9.2 Requirements for front position lamp

| Lighting groups (see Annex A) | I | | | II | | | III | | |
|--|-----|---|---|------------------|---|---|-----|---|------------------|
| | A | B | C | A | B | C | A | B | C |
| Application to machines | N/A | | | S | S | S | N/A | | O |
| Number | N/A | | | Two ^a | | | N/A | | Two ^a |
| Dimensions, in mm | | | | | | | | | |
| H_1 | N/A | | | $\leq 1\,500^b$ | | | N/A | | $\leq 1\,500^c$ |
| H_2 | N/A | | | > 400 | | | N/A | | > 600 |
| E | N/A | | | ≤ 400 | | | N/A | | $\leq 400^d$ |
| D | N/A | | | $> 500^e$ | | | N/A | | $> 500^e$ |
| Geometric visibility, min. angles | | | | | | | | | |
| α_1 | N/A | | | 15° | | | N/A | | 15° |
| α_2 | N/A | | | 15°^f | | | N/A | | 15°^f |
| β_1 | N/A | | | 80° | | | N/A | | 80° |
| β_2 | N/A | | | 45°^g | | | N/A | | 45°^h |
| Electrical connections | N/A | | | i | | | N/A | | i |
| Tell-tale | N/A | | | j | | | N/A | | j |
| Other requirements | N/A | | | k | | | N/A | | k |
| When national requirements differ from those presented here, the national requirements may be applied. | | | | | | | | | |
| Exceptions: | | | | | | | | | |
| a Four may be used [see d)]. The additional front position lamps shall be grouped or reciprocally incorporated with additional lamps. | | | | | | | | | |
| b May be fitted higher if the design of the bodywork makes it impossible to meet the requirement of $\leq 1\,500$ mm: maximum height shall be 2 100 mm. | | | | | | | | | |
| c May be fitted higher, if the design of the bodywork makes it impossible to meet the requirement of $\leq 1\,500$ mm. | | | | | | | | | |
| d May be > 400 mm if the design of the bodywork makes it impossible to meet the requirement of ≤ 400 mm. | | | | | | | | | |
| e May be reduced if the design of the bodywork makes it impossible to meet the requirement of > 500 mm, e.g. on rear-dump dumper. | | | | | | | | | |
| f May be reduced to 5° depending on the earth-moving machine structure. | | | | | | | | | |
| g May be reduced to 10° if the structure and/or attachment makes 45° impossible. | | | | | | | | | |
| h May be reduced to 5° if the structure and/or attachment makes 45° impossible. | | | | | | | | | |
| i The electrical connections shall be such that the front position lamps, together with rear-position lamps, are switched on when the dipped/lower beam light and main/upper beam light are switched on. They shall be symmetrical in relation to the median longitudinal plane. | | | | | | | | | |
| j If any, a circuit-closed tell-tale shall be non-flashing. | | | | | | | | | |
| k The front position lamps shall not dazzle. | | | | | | | | | |

E.10 Data sheet

E.10.1 Rear position lamp: the lamp used to indicate the presence and width of the earth-moving machine when viewed from the rear. See Figure E.15.

E.10.1.1 Colour of light: red.

E.10.1.2 Alignment: towards the rear.

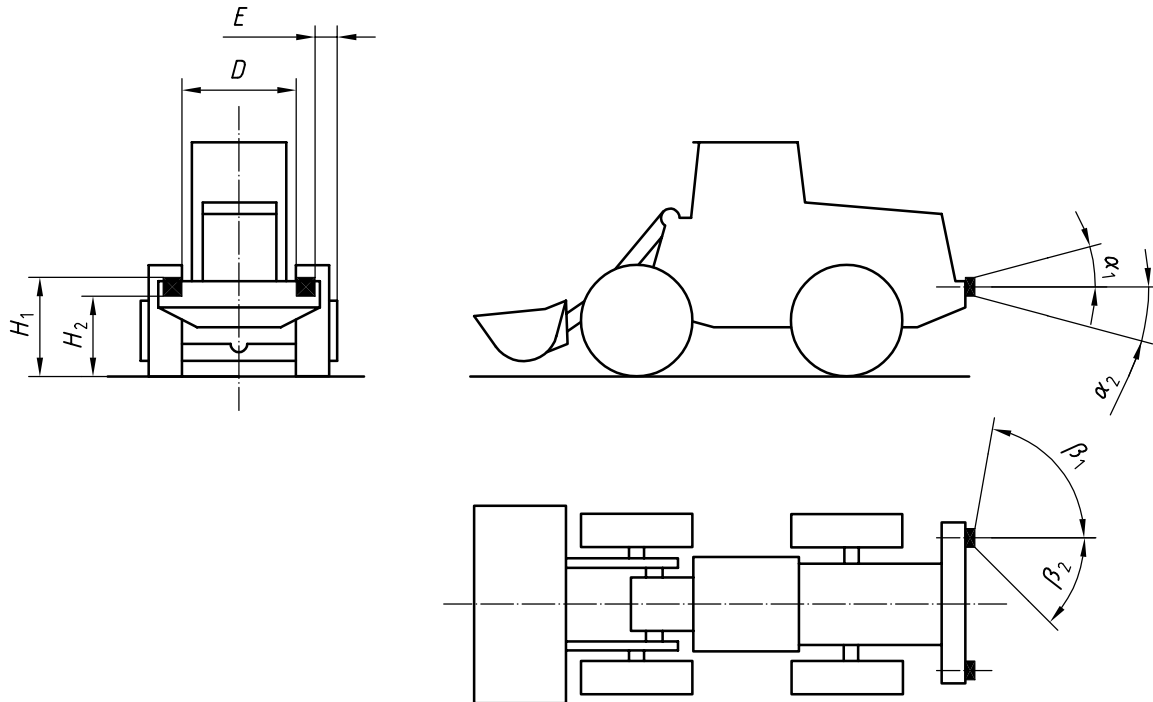

Figure E.15

E.10.1.3 Configuration: the rear position lamp

- a) may be grouped with any other rear lamp,
- b) may be combined with the rear registration-plate lamp, and
- c) may be reciprocally incorporated with
 - the stop lamp,
 - the rear fog lamp.

E.10.2 Requirements for rear position lamp

| Lighting groups (see Annex A) | I | | | II | | | III | | | |
|--|-----------------------|---|----------------|----------------|----------------|----------------|-----|--------------------------|----------------|--|
| | A | B | C | A | B | C | A | B | C | |
| Application to machines | O | O | S ^a | S ^a | S ^a | S ^a | N/A | O | S ^a | |
| Number | Minimum of two | | | | | | N/A | Minimum of two | | |
| Dimensions, in mm | | | | | | | | | | |
| H_1 | $\leq 1\,500^b$ | | | | | | N/A | $\leq 1\,500^c$ | | |
| H_2 | > 400 | | | | | | N/A | > 600 | | |
| E | $\leq 400^d$ | | | ≤ 400 | | | N/A | $\leq 400^d$ | | |
| D | $> 500^e$ | | | | | | N/A | $> 500^e$ | | |
| Geometric visibility, min. angles | | | | | | | | | | |
| α_1 | 15° | | | | | | N/A | 15° | | |
| α_2 | 15°^f | | | | | | N/A | 15°^f | | |
| β_1 | $80^\circ/45^\circ^g$ | | | | | | N/A | $80^\circ/45^\circ^g, j$ | | |
| β_2 | $45^\circ/80^\circ^g$ | | | | | | N/A | $80^\circ/45^\circ^g, j$ | | |
| Electrical connections | h | | | | | | N/A | h | | |
| Tell-tale | i | | | | | | N/A | i | | |
| Other requirements | N/A | | | | | | | | | |
| Exceptions: | | | | | | | | | | |
| a Not applicable to steel-tracked or steel-pad-foot wheeled machines. | | | | | | | | | | |
| b May be fitted higher if the design of the bodywork makes it impossible to meet the requirement of $\leq 1\,500$ mm: maximum height shall be 2 100 mm. | | | | | | | | | | |
| c May be fitted higher, if the design of the bodywork makes it impossible to meet the requirement of $\leq 1\,500$ mm. | | | | | | | | | | |
| d May be, depending on the earth-moving machine structure, > 400 mm (from the extreme outer edge of the earth-moving machine). | | | | | | | | | | |
| e May be reduced if the design of the bodywork makes it impossible to meet the requirement of > 500 mm, e.g. on rear-dump dumper or machines with an overall width $< 1\,400$ mm. | | | | | | | | | | |
| f May be reduced to 5° , depending on the structure of the earth-moving machine. | | | | | | | | | | |
| g Horizontal angle of the two rear-position lamps: | | | | | | | | | | |
| — either 45° inwards and 80° outwards, | | | | | | | | | | |
| — or 80° inwards and 45° outwards. | | | | | | | | | | |
| h The rear-position lamps shall be switched on together with the front-position lamps when the dipped/lower beam and main/upper beam lights are switched on. | | | | | | | | | | |
| i If any, the tell-tale shall be non-flashing, circuit-closed and combined with the circuit-closed tell-tale of the front-position lamps. | | | | | | | | | | |
| j The angle 80° may be reduced to 50° and the angle 45° to 30° , depending on the earth-moving machine structure. These angles may be further reduced if the design of the bodywork makes 50° and 30° impossible on machines with rear-mounted working equipment or on rear-dump dumpers not used on public roads. | | | | | | | | | | |

E.11 Data sheet

E.11.1 Rear fog lamp: the lamp used to signal the presence of the earth-moving machine from the rear in conditions of fog or other conditions which adversely affect visibility. See Figure E.16.

E.11.1.1 Colour of light: red.

E.11.1.2 Alignment: towards the rear.

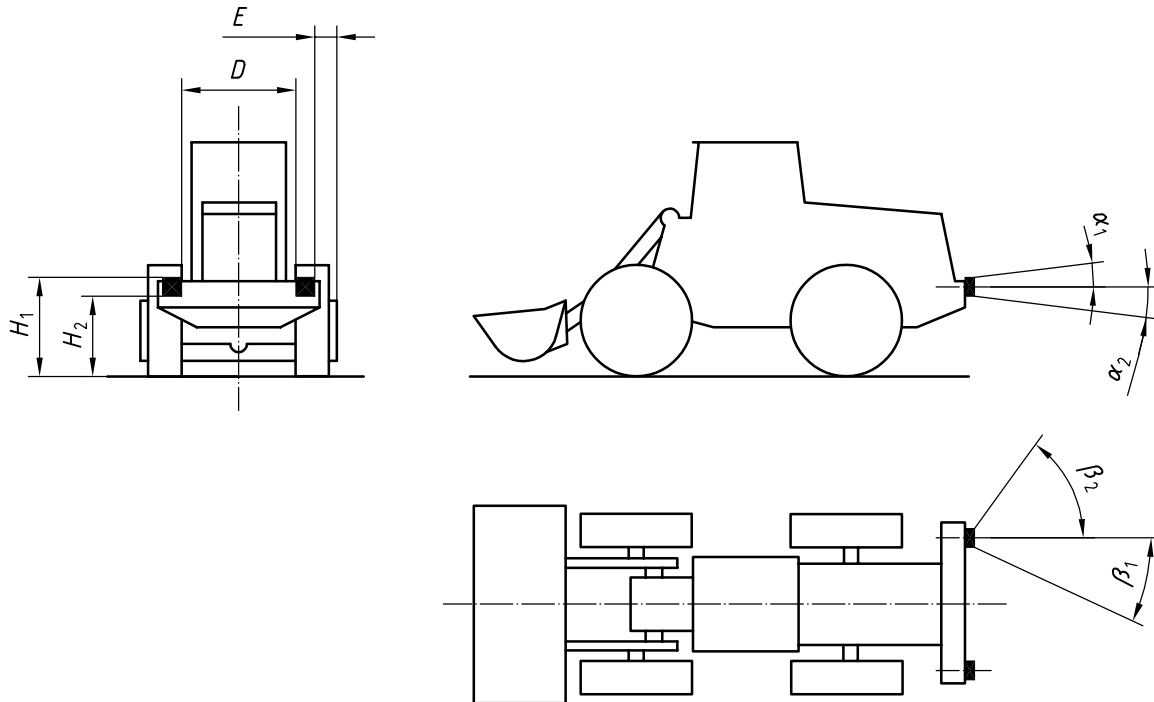

Figure E.16

E.11.1.3 Configuration: the rear fog lamp

- may be grouped with any other rear lamp,
- may be combined with other lamps, and
- may be reciprocally incorporated with a rear position lamp.

E.11.2 Requirements for rear fog lamp

| Lighting groups (see Annex A) | I | | | II | | | III | | |
|--|-----|---|---|------------------|----------------|-----|-----|---|---|
| | A | B | C | A | B | C | A | B | C |
| Application to machines | N/A | | | O | O ^a | N/A | | | |
| Number | N/A | | | One ^b | | | N/A | | |
| Dimensions, in mm | | | | | | | | | |
| H_1 | N/A | | | $\leq 1\,500^c$ | | | N/A | | |
| H_2 | N/A | | | > 400 | | | N/A | | |
| E | | | | N/A | | | | | |
| D | | | | N/A | | | | | |
| Geometric visibility, min. angles | | | | | | | | | |
| α_1 | N/A | | | 5° | | | N/A | | |
| α_2 | N/A | | | 5° | | | N/A | | |
| β_1 | N/A | | | 25° | | | N/A | | |
| β_2 | N/A | | | 55° | | | N/A | | |
| Electrical connections | N/A | | | d | | | N/A | | |
| Tell-tale | N/A | | | e | | | N/A | | |
| Other requirements | N/A | | | f | | | N/A | | |
| Exceptions: | | | | | | | | | |
| a Application S shall be used if the maximum speed exceeds 60 km/h. | | | | | | | | | |
| b Two are optional. | | | | | | | | | |
| c May be fitted higher if the design of the bodywork makes it impossible to meet the requirement of $\leq 1\,500$ mm: maximum height shall be 2 100 mm. | | | | | | | | | |
| d May only operate when the dipper/lower beam headlamp or the main/upper beam headlamp are switched on. | | | | | | | | | |
| e Circuit-closed, non-flashing, tell-tale is required. | | | | | | | | | |
| f When only one rear fog lamp is fitted, it shall be positioned on the opposite side of the median longitudinal plane of the machine to the direction of traffic prescribed in the country where the machine is used. The distance between the rear fog lamp and the stop lamps shall be > 100 mm. | | | | | | | | | |

E.12 Data sheet

E.12.1 Special warning light: a flashing lamp, used to indicate the presence of an earth-moving machine to other road-users or exposed persons. See Figure E.17.

E.12.1.1 Colour of light: yellow or amber.

E.12.1.2 Alignment: all around.

Dimensions in metres

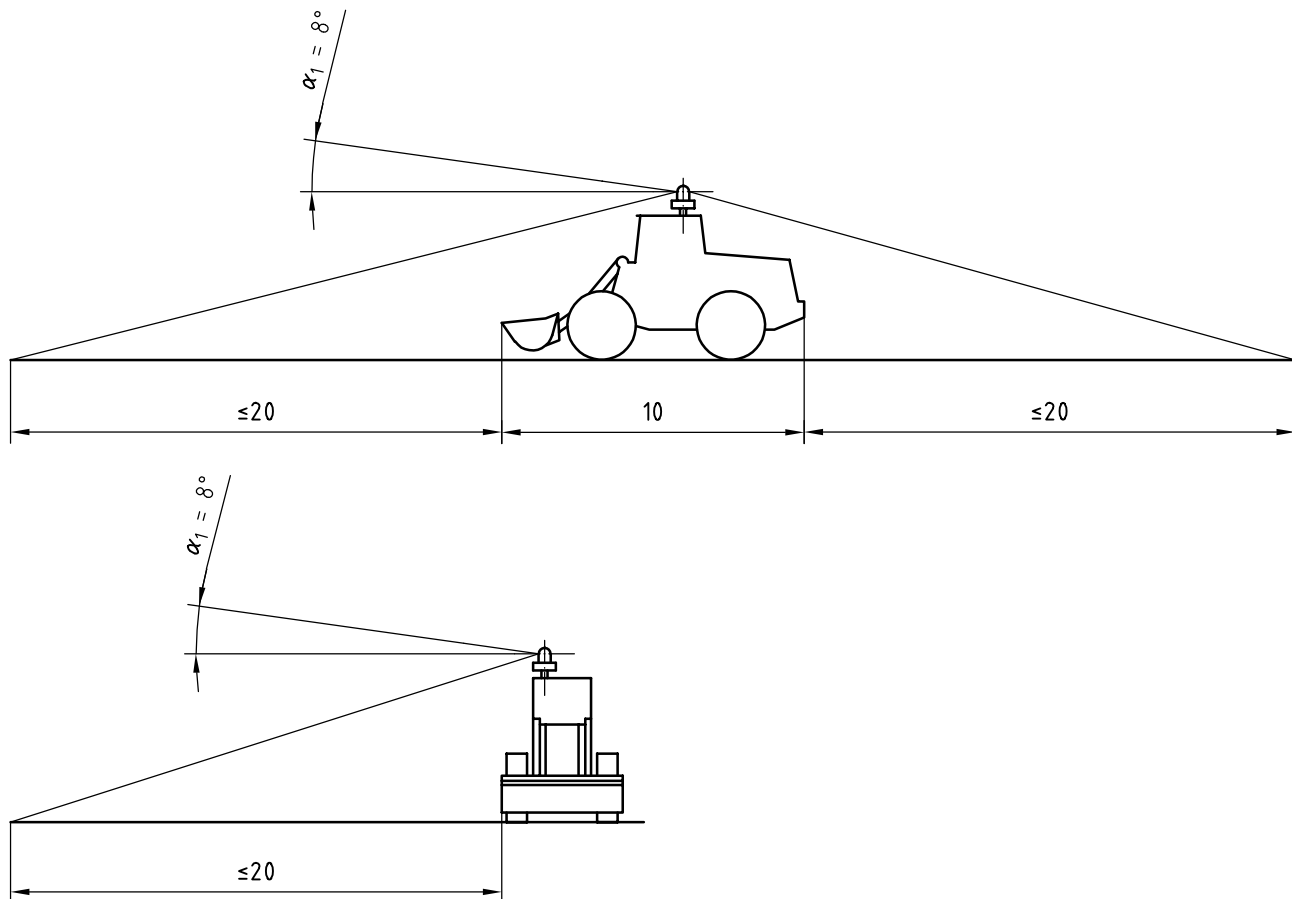

Figure E.17

E.12.1.3 Configuration: this special yellow or amber warning light.

Shall not be grouped, combined or reciprocally incorporated with any other lamp.

E.12.2 Requirements for special warning light

| Lighting groups (see Annex A) | I | | | II | | | III | | |
|--|---|---|---|----|---|---|-----|---|---|
| | A | B | C | A | B | C | A | B | C |
| Application to machines | ○ | ○ | ○ | ○ | ○ | ○ | ○ | ○ | ○ |
| Number | One or more (when the horizontal and vertical visibility so requires) | | | | | | | | |
| Dimensions , in mm | | | | | | | | | |
| H_1 | Height and visibility ^a | | | | | | | | |
| H_2 | N/A | | | | | | | | |
| E | N/A | | | | | | | | |
| D | N/A | | | | | | | | |
| Geometric visibility , min. angles | | | | | | | | | |
| α_1 | 8° | | | | | | | | |
| α_2 | Shall light up the ground 20 m from the periphery of the machine | | | | | | | | |
| β_1 | 360° | | | | | | | | |
| β_2 | | | | | | | | | |
| Electrical connections | N/A | | | | | | | | |
| Tell-tale | Fixed amber light | | | | | | | | |
| Other requirements | b | | | | | | | | |
| Exceptions: | | | | | | | | | |
| a One special warning light shall always be visible within the zone prescribed by α_2 . | | | | | | | | | |
| b Flashing frequency 2 Hz to 4 Hz (120 times/min. to 240 times/min.). The special warning light(s) shall be fitted in a conspicuous place: preferably on the top of the operator's cab in order to avoid dazzling the operator. The special warning light may be foldable or detachable. | | | | | | | | | |

E.13 Data sheet

E.13.1 Rear reflex reflector (non-triangular): a device used to indicate the presence of the rear of an earth-moving machine by the reflection of light emanating from a light source not connected to the earth-moving machine, the observer being situated near the light source. See Figure E.18.

E.13.1.1 Colour of light: red.

E.13.1.2 Alignment: towards the rear.

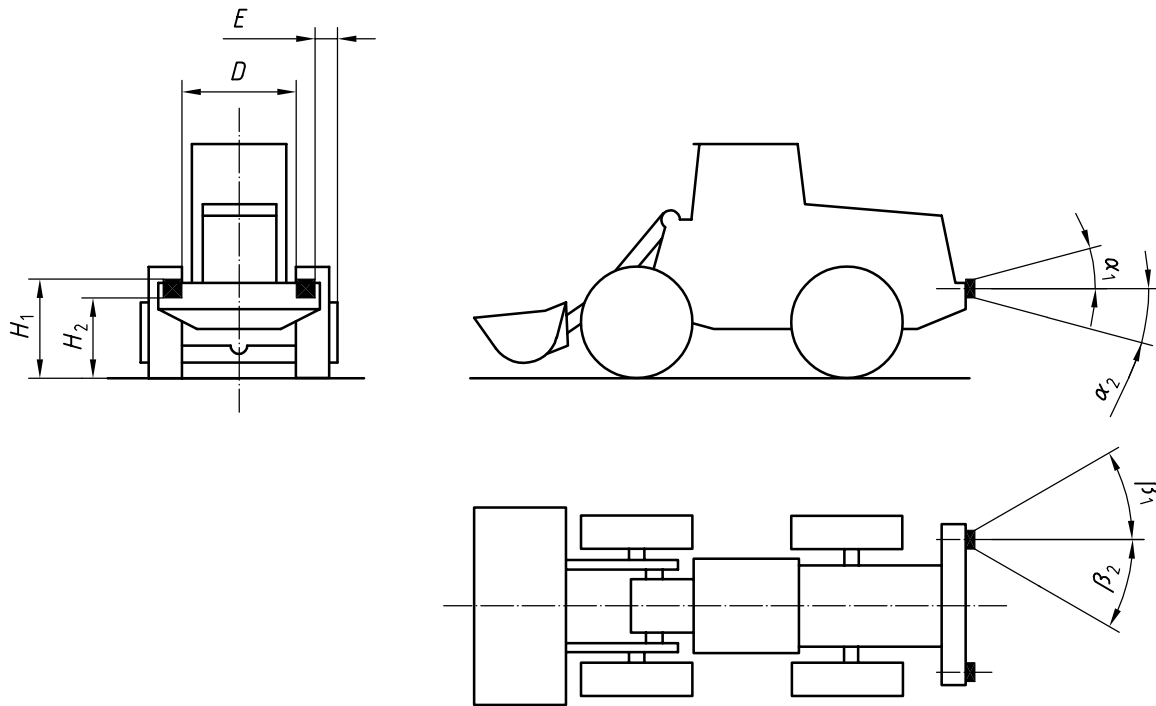

Figure E.18

E.13.1.3 Configuration: the rear reflex reflector may be grouped with any other rear lamp or lamps.

E.13.2 Requirements for rear reflex reflector (non-triangular)

| Lighting groups (see Annex A) | I | | | II | | | III | | |
|---|---|---|---|--------------|---|---|--------------|---|---|
| | A | B | C | A | B | C | A | B | C |
| Application to machines | S | S | S | S | S | S | S | S | S |
| Number | Two or four ^a | | | | | | | | |
| Dimensions, in mm | | | | | | | | | |
| H_1 | $\leq 900^b$ | | | $\leq 900^c$ | | | $\leq 900^b$ | | |
| H_2 | > 400 | | | | | | > 600 | | |
| E | $\leq 400^d$ | | | ≤ 400 | | | $\leq 400^d$ | | |
| D | $> 500^e$ | | | | | | | | |
| Geometric visibility, min. angles | | | | | | | | | |
| α_1 | 15° | | | | | | | | |
| α_2 | 15°^f | | | | | | | | |
| β_1 | 30°^g | | | | | | 30°^h | | |
| β_2 | 30°^g | | | | | | 30°^h | | |
| Electrical connections | The illuminating surface of the rear reflex reflector may have common parts with any other rear lamp. | | | | | | | | |
| Exceptions: | | | | | | | | | |
| a If it is not possible to comply with the position and visibility using two rear reflex reflectors, four may be fitted. | | | | | | | | | |
| b May be > 900 mm from the ground if the design of the bodywork makes it impossible to meet the requirement of ≤ 900 mm. | | | | | | | | | |
| c May be > 900 mm from the ground if the design of the bodywork makes it impossible to meet the requirement of ≤ 900 mm: maximum height shall be 1 500 mm. | | | | | | | | | |
| d May be > 400 mm if the design of the bodywork makes it impossible to meet the requirement of ≤ 400 mm. | | | | | | | | | |
| e May be reduced if the design of the bodywork makes it impossible to meet the requirement of > 500 mm. | | | | | | | | | |
| f May be reduced to 5° if the rear reflex reflector minimum height above ground is 900 mm. | | | | | | | | | |
| g May be complied with by using two separate rear reflex reflectors. | | | | | | | | | |
| h May be reduced if the design of the bodywork makes 30° impossible. | | | | | | | | | |

E.14 Data sheet

E.14.1 Front reflex reflector (non-triangular): a device used to indicate the presence of the front of an earth-moving machine by the reflection of light emanating from a light source not connected to the earth-moving machine, the observer being situated near the light source. See Figure E.19.

E.14.1.1 Colour of light: white or colourless.

E.14.1.2 Alignment: towards the front.

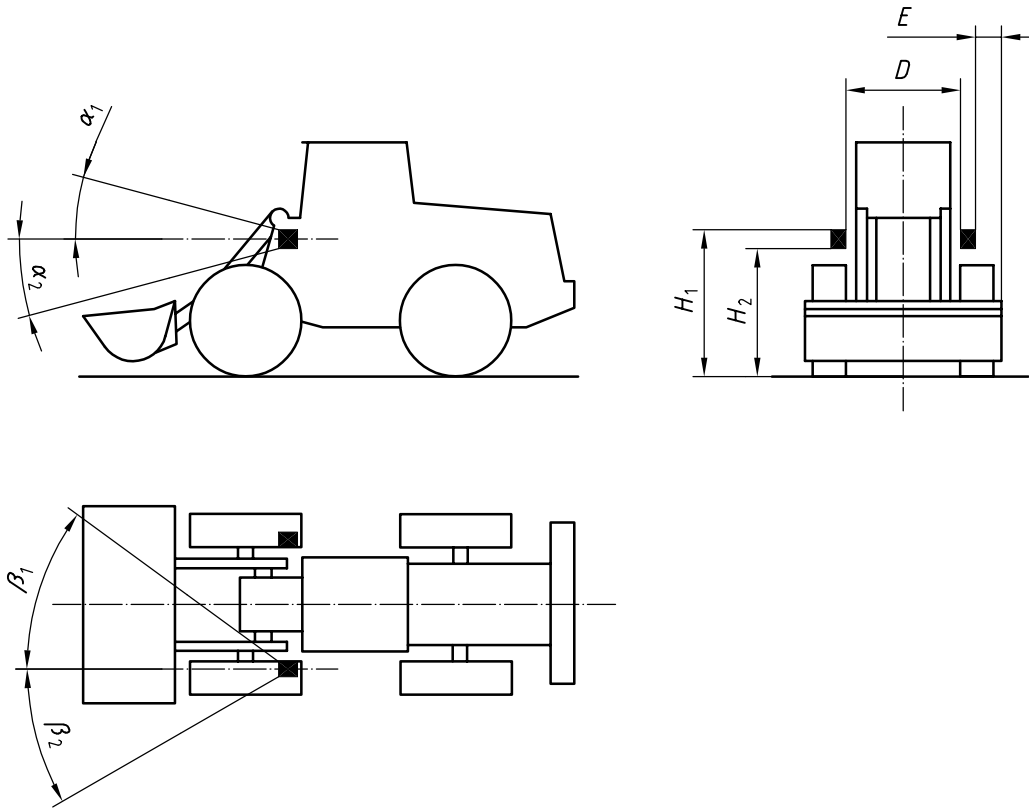

Figure E.19

E.14.1.3 Configuration: the front reflex reflector, Class I A, may be grouped with the front position lamp.

E.14.2 Requirements for front reflex reflector (non-triangular)

| Lighting groups (see Annex A) | I | | | II | | | III | | |
|---|---|---|---|-----|---|---|-----------------|---|---|
| | A | B | C | A | B | C | A | B | C |
| Application to machines | O | O | O | O | O | O | O | O | O |
| Number | Two | | | | | | | | |
| Dimensions, in mm | | | | | | | | | |
| H_1 | $\leq 900^a$ | | | N/A | | | $\leq 1\,500^b$ | | |
| H_2 | > 400 | | | N/A | | | > 600 | | |
| E | $\leq 400^c$ | | | N/A | | | $\leq 500^d$ | | |
| D | > 400 | | | N/A | | | $> 600^e$ | | |
| Geometric visibility, min. angles | | | | | | | | | |
| α_1 | 15° | | | N/A | | | 15° | | |
| α_2 | 15°^f | | | N/A | | | 15°^f | | |
| β_1 | 30°^g | | | N/A | | | 30°^g | | |
| β_2 | 30° | | | N/A | | | 30° | | |
| Electrical connections | The illuminating surface of the front reflex reflector may have common parts with any other front lamp. | | | | | | | | |
| Exceptions: | | | | | | | | | |
| a May be fitted higher if the design of the bodywork makes it impossible to meet the requirement of ≤ 900 mm. | | | | | | | | | |
| b May be positioned higher if the design of the bodywork makes it impossible to meet the requirement of $\leq 1\,500$ mm. | | | | | | | | | |
| c May be increased if the design of the body work makes it impossible to meet the requirement of ≤ 400 mm. | | | | | | | | | |
| d May be increased if the design of the bodywork makes it impossible to meet the requirement of ≤ 500 mm. | | | | | | | | | |
| e May be reduced if the design of the bodywork makes it impossible to meet the requirement of > 600 mm. | | | | | | | | | |
| f May be reduced to 5° if the front reflex reflectors are placed 900 mm above the ground. | | | | | | | | | |
| g May be reduced to 10° when the design of the bodywork makes 30° impossible. | | | | | | | | | |

E.15 Data sheet

E.15.1 Side reflex reflector (non-triangular): a device used to indicate the presence of the side of an earth-moving machine by the reflection of light emanating from a light source not connected to the earth-moving machine, the observer being situated near the light source. See Figure E.20.

E.15.1.1 Colour of light: amber.

E.15.1.2 Alignment: towards the side.

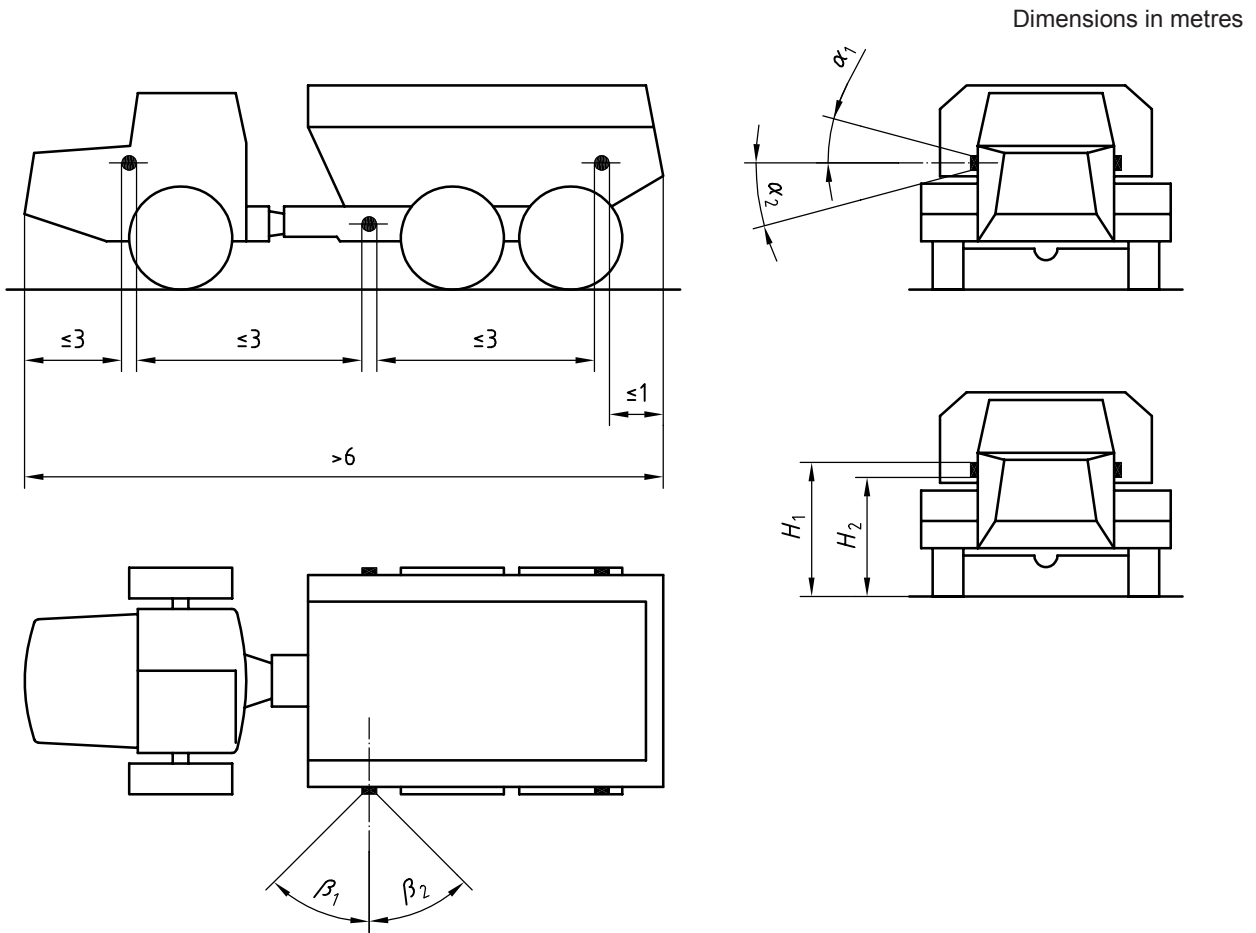

Figure E.20

E.15.1.3 Configuration: the front reflex reflector shall not be grouped with any other lamp.

E.15.2 Requirements for side reflex reflector (non-triangular)

| Lighting groups (see Annex A) | I | | | II | | | III | | |
|---|------------------|---|---|-------------------|---|---|------------------|---|---|
| | A | B | C | A | B | C | A | B | C |
| Application to machines | N/A | O | | S ^{a, b} | | | O | | |
| Number | N/A | Minimum number per side according to E.15.1.2, that the longitudinal positioning are complied with. | | | | | | | |
| Dimensions, in mm | | | | | | | | | |
| H_1 | 900 ^c | | | 900 ^d | | | 900 ^c | | |
| H_2 | > 400 | | | | | | | | |
| E | N/A | | | | | | | | |
| D | N/A | | | | | | | | |
| Geometric visibility, min. angles | | | | | | | | | |
| α_1 | 15° | | | | | | | | |
| α_2 | 15° ^e | | | | | | | | |
| β_1 | 45° | | | | | | | | |
| β_2 | 45° | | | | | | | | |
| Other requirements | f | | | | | | | | |
| Exceptions: | | | | | | | | | |
| a Not applicable to steel-tracked or steel-pad-foot wheeled machines. | | | | | | | | | |
| b Applicable to earth-moving machinery with a base machine length of > 6 m. | | | | | | | | | |
| c May be > 900 mm if the design of the bodywork makes it impossible to meet the requirement of 900 mm. | | | | | | | | | |
| d May be > 900 mm if the design of the bodywork makes it impossible to meet the requirement of 900 mm: maximum height shall be 1 500 mm. | | | | | | | | | |
| e May be reduced to 5° when the design of the bodywork 15° impossible. | | | | | | | | | |
| f One side reflex reflector shall be fitted to the middle third of the machine, the foremost side reflex reflector being not further than 3 m from the foremost point of the machine. The distance between two adjacent side reflex reflectors shall not exceed 3 m. The distance between the rearmost side reflex reflector and the rear of the machine shall not exceed 1 m. The reference axis of the side reflex reflector shall be horizontal and vertical to the machine's median longitudinal plane and directed outward. See Figure E.20. | | | | | | | | | |

E.16 Data sheet

E.16.1 Slow-moving vehicle (SMV) plate: the plate used to indicate to other road-users coming from behind the presence of a slow-moving (by design) earth-moving machine. See Figure E.21.

E.16.1.1 Colour of retro-reflecting light: red.

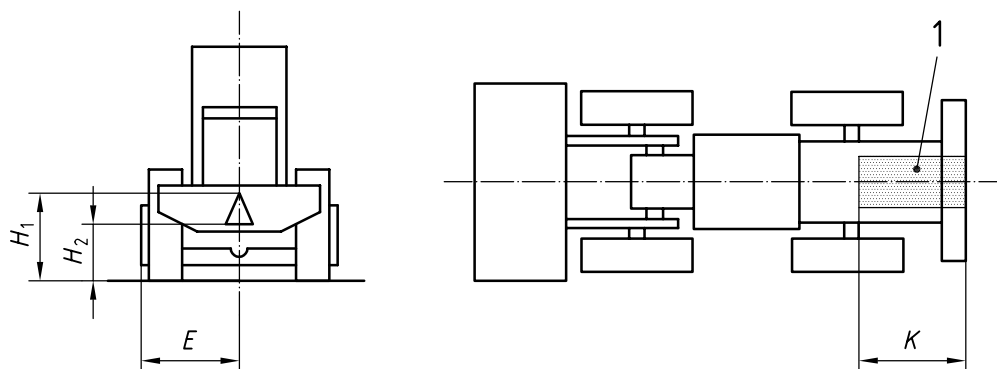

Key

1 area in which the plate is mounted

Figure E.21

E.16.2 Requirements for slow-moving (SMV) plate

| Lighting groups (see Annex A) | I | | | II | | | III | | |
|--|----------------------|---|-----|----------------------|---|-----|-----|---|---|
| | A | B | C | A | B | C | A | B | C |
| Application to machines | O ^a | | N/A | O ^b | | N/A | N/A | | |
| Number | One rear | | N/A | One rear | | N/A | N/A | | |
| Dimensions, in mm | | | | | | | | | |
| <i>H</i> ₁ | ≤ 1 800 ^c | | N/A | ≤ 1 800 ^c | | N/A | N/A | | |
| <i>H</i> ₂ | > 600 ^c | | N/A | > 600 ^c | | N/A | N/A | | |
| <i>E</i> | d | | N/A | d | | N/A | N/A | | |
| <i>K</i> | ≤ 2 000 ^e | | N/A | ≤ 2 000 ^e | | N/A | N/A | | |
| Other requirements | f, g | | N/A | f, g | | N/A | N/A | | |
| Exceptions: | | | | | | | | | |
| <p>a Rubber tyred machines and machines on soft tracks in lighting groups I A et I B with a ride-on operator, working on worksites with surrounding traffic or when transferring on road between worksites, shall have a SMV-plate during these operations.</p> <p>b Earth-moving machines having a maximum design speed of ≤ 40 km/h and using public roads shall have an SMV-plate. One apex of the SMV plate shall be directed upwards.</p> <p>c Shall be measured from the ground to the lower edge of the plate. If the design of the bodywork makes it impossible to meet the requirement of ≤ 1 800 mm and > 600 m, the plate may be positioned higher or lower, but shall be vertical and perpendicular to the median longitudinal plane of the machine with a deviation of ≤ 10°.</p> <p>d May be fitted at the rear of the centreline of the machine or horizontal and vertical to the machine's median longitudinal plane and directed outward.</p> <p>e Measured from the rear of the base machine. Attachment at the rear should not be included. May be > 2 000 mm if the design of the bodywork makes the ≤ 2 000 mm dimension impossible.</p> <p>f SMV-plate shall not be fitted behind a rear window or any other pane of glass.</p> <p>g During operations the SMV-plate at the rear of the earth-moving machine may be folded away or detached.</p> | | | | | | | | | |

Annex F (informative)

Location of lighting, signalling and marking lights, and reflex-reflector devices

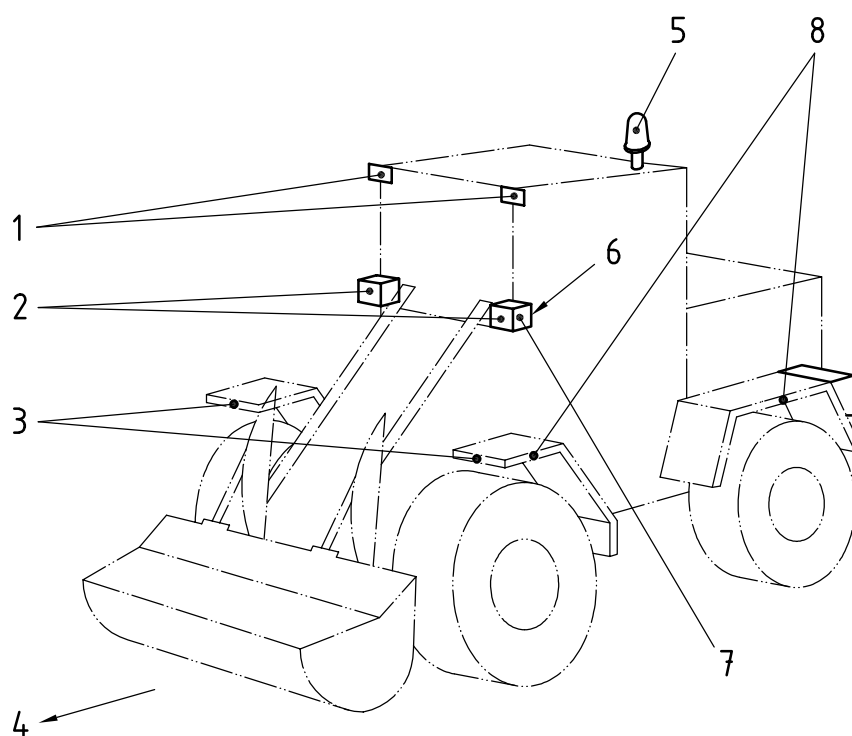

Key

- 1 work lamp
- 2 dipped-beam and main-beam headlights
- 3 front reflex reflector
- 4 front of machine
- 5 special warning light (yellow)
- 6 direction-indicator lamp/hazard warning signal
- 7 front-position lamp
- 8 side reflex reflector

Figure F.1

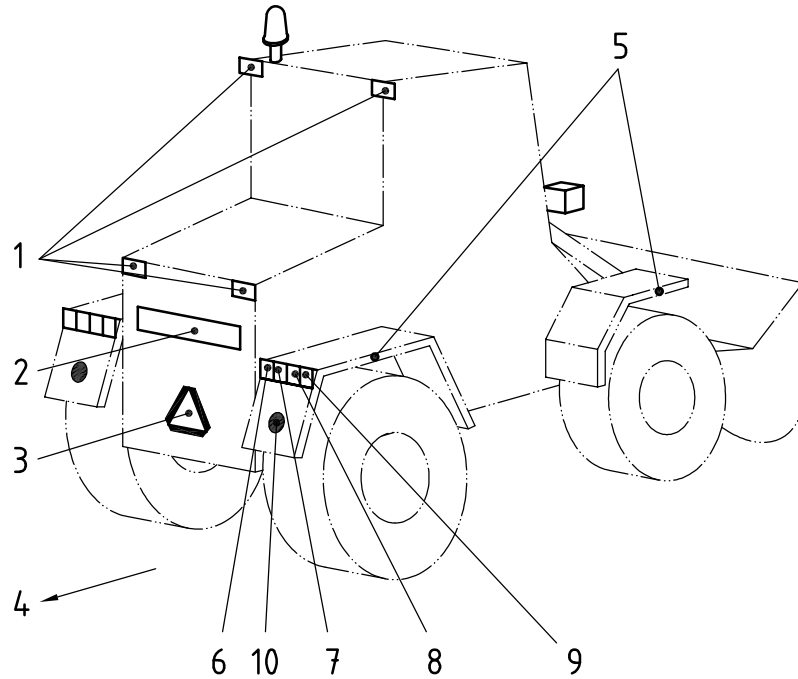

Key

- 1 work lamp
- 2 rear registration-plate lamp
- 3 slow-moving vehicle (SMV) plate
- 4 rear of machine
- 5 side reflex reflector
- 6 stop lamp
- 7 reverse lamp
- 8 rear position lamp/rear fog lamp
- 9 direction indicator lamp/hazard warning signal
- 10 rear reflex reflector

Figure F.2

Annex G (informative)

Earth-moving machinery from representative machine families

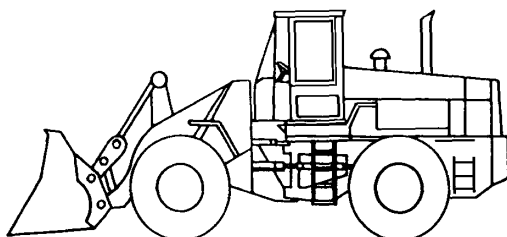

Figure G.1 — Wheel loader

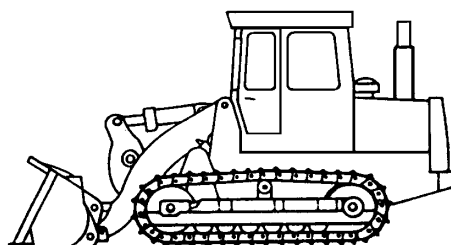

Figure G.2 — Crawler loader

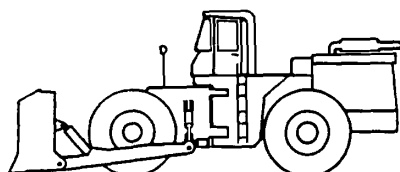

Figure G.3 — Wheel tractor-dozer

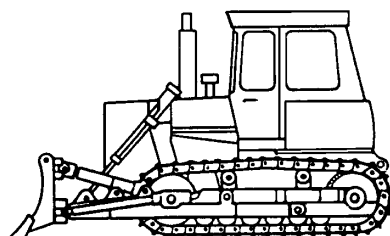

Figure G.4 — Crawler tractor-dozer

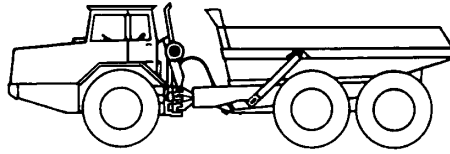

Figure G.5 — Articulated frame dumper

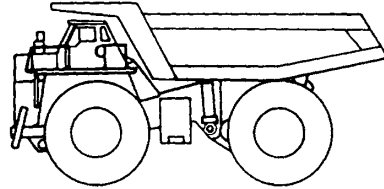

Figure G.6 — Rigid frame dumper

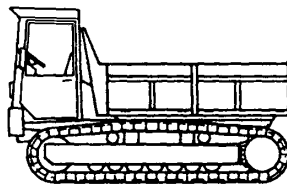

Figure G.7 — Compact (crawler) dumper

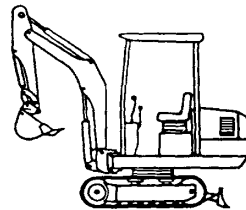

Figure G.8 — Compact excavator

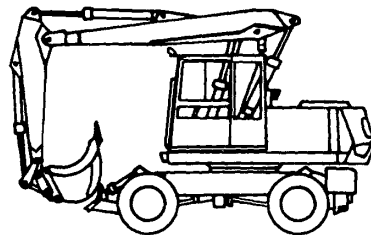

Figure G.9 — Hydraulic wheel excavator

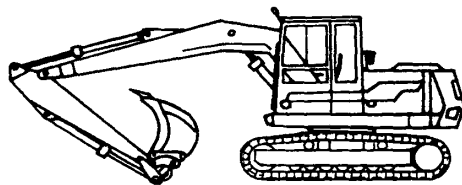

Figure G.10 — Hydraulic crawler excavator

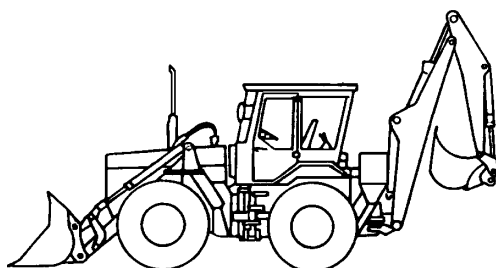

Figure G.11 — Wheel backhoe loader

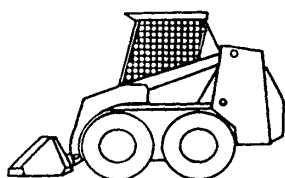

Figure G.12 — Compact loader

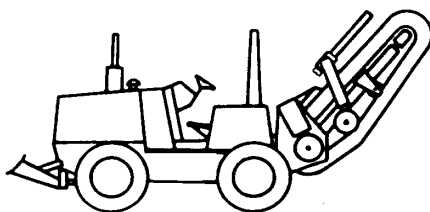

Figure G.13 — Trencher

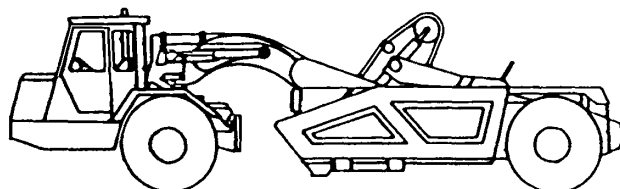

Figure G.14 — Tractor-scraper

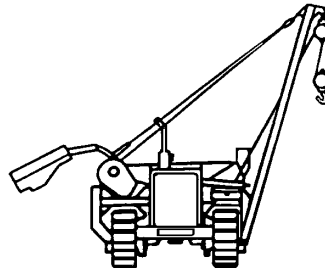

Figure G.15 — Pipelayer

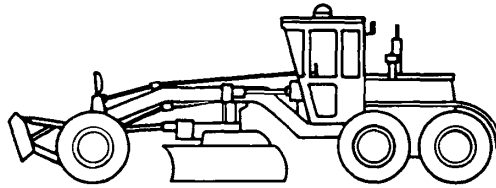

Figure G.16 — Grader

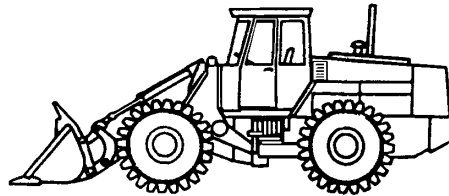

Figure G.17 — Compactor

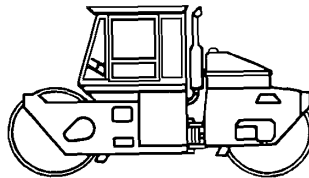

Figure G.18 — Roller

Annex H (informative)

ECE regulations for lighting and light signalling devices, lights, special warning lights, direction-indicators, retro-reflecting devices, lamps and slow-moving vehicles plate

ECE regulations for power-driven vehicles intended for use on the road can be helpful when a manufacturer of earth-moving machinery is choosing among lighting, signalling and marking lights, and reflex-reflector devices for a machine. This would be especially true for machines likely to travel on public roads e.g. between worksites.

The Regulations also specify performance requirements that provide adequate illumination for driving, so others are able to see the machines under driving situations.

- ECE R1 *Uniform provisions concerning the approval of motor vehicle headlamps emitting an asymmetrical passing beam and/or a driving beam and equipped with filament lamps of category R2*
- ECE R2 *Uniform provisions concerning the approval of incandescent electric lamps for headlamps emitting an asymmetrical passing beam or a driving beam or both*
- ECE R3 *Uniform provisions concerning the approval of retro-reflecting devices for power driven vehicles and their trailer*
- ECE R4 *Uniform provisions for the approval of devices for the illumination of rear registration plates of motor vehicles (except motor cycles) and their trailers*
- ECE R5 *Uniform provisions for the approval of motor vehicles "sealed beam" headlamps (SB) emitting a European asymmetrical passing beam or a driving beam or both*
- ECE R6 *Uniform provisions concerning the approval of direction-indicators for motor vehicles and their trailers*
- ECE R7 *Uniform provisions concerning the approval of front and rear position (side) lamps, stop-lamps and end-outline marker lamps for motor vehicles (except motor cycles) and their trailers*
- ECE R8 *Uniform provisions concerning the approval of motor vehicle headlamps emitting an asymmetrical passing beam or driving beam or both and equipped with halogen lamps (H1, H2 or H3 lamps)*
- ECE R20 *Uniform provisions concerning the approval of motor vehicle headlamps emitting an asymmetrical passing beam or a driving beam, or both and equipped with halogen filament lamps (H4 lamps)*
- ECE R23 *Uniform provisions concerning the approval of reversing lights for power-driven vehicles and their trailers*
- ECE R31 *Uniform provisions concerning the approval of halogen sealed-beam unit (HSB unit) motor vehicle headlamps emitting an asymmetrical passing beam or a driving beam, or both*
- ECE R37 *Uniform provisions concerning the approval of filament lamps for use in approved lamps units of power-driven vehicles and of their trailers*
- ECE R38 *Uniform provisions concerning the approval of rear fog lamps for power-driven vehicles and their trailers*
- ECE R65 *Uniform provisions concerning the approval of special warning lights for motor vehicles*

- ECE R69 *Uniform provisions concerning the approval of rear-marking plates for slow moving vehicles (by construction) and their trailers*
- ECE R91 *Uniform provisions concerning the approval of side-marker lamps for motor vehicles and their trailers*

Bibliography

- [1] ISO 6016, *Earth-moving machinery — Methods of measuring the masses of whole machines, their equipment and components*
- [2] ISO 6746-1, *Earth-moving machinery — Definitions of dimensions and codes — Part 1: Base machine*
- [3] ISO 6747, *Earth-moving machinery — Tractor-dozers — Terminology and commercial specifications*
- [4] ISO 7131, *Earth-moving machinery — Loaders — Terminology and commercial specifications*
- [5] ISO 7132, *Earth-moving machinery — Dumpers — Terminology and commercial specifications*
- [6] ISO 7133, *Earth-moving machinery — Tractor-scrapers — Terminology and commercial specifications*
- [7] ISO 7134, *Earth-moving machinery — Graders — Terminology and commercial specifications*
- [8] ISO 7135, *Earth-moving machinery — Hydraulic excavators — Terminology and commercial specifications*
- [9] ISO 7136, *Earth-moving machinery — Pipelayers — Terminology and commercial specifications*
- [10] CIE S004, *Colours of Light Signals*¹⁾

1) International Commission on Illumination standard.

British Standards Institution (BSI)

BSI is the national body responsible for preparing British Standards and other standards-related publications, information and services.

BSI is incorporated by Royal Charter. British Standards and other standardization products are published by BSI Standards Limited.

About us

We bring together business, industry, government, consumers, innovators and others to shape their combined experience and expertise into standards-based solutions.

The knowledge embodied in our standards has been carefully assembled in a dependable format and refined through our open consultation process. Organizations of all sizes and across all sectors choose standards to help them achieve their goals.

Information on standards

We can provide you with the knowledge that your organization needs to succeed. Find out more about British Standards by visiting our website at bsigroup.com/standards or contacting our Customer Services team or Knowledge Centre.

Buying standards

You can buy and download PDF versions of BSI publications, including British and adopted European and international standards, through our website at bsigroup.com/shop, where hard copies can also be purchased.

If you need international and foreign standards from other Standards Development Organizations, hard copies can be ordered from our Customer Services team.

Copyright in BSI publications

All the content in BSI publications, including British Standards, is the property of and copyrighted by BSI or some person or entity that owns copyright in the information used (such as the international standardization bodies) and has formally licensed such information to BSI for commercial publication and use.

Save for the provisions below, you may not transfer, share or disseminate any portion of the standard to any other person. You may not adapt, distribute, commercially exploit, or publicly display the standard or any portion thereof in any manner whatsoever without BSI's prior written consent.

Storing and using standards

Standards purchased in soft copy format:

- A British Standard purchased in soft copy format is licensed to a sole named user for personal or internal company use only.
- The standard may be stored on more than 1 device provided that it is accessible by the sole named user only and that only 1 copy is accessed at any one time.
- A single paper copy may be printed for personal or internal company use only.

Standards purchased in hard copy format:

- A British Standard purchased in hard copy format is for personal or internal company use only.
- It may not be further reproduced – in any format – to create an additional copy. This includes scanning of the document.

If you need more than 1 copy of the document, or if you wish to share the document on an internal network, you can save money by choosing a subscription product (see 'Subscriptions').

Reproducing extracts

For permission to reproduce content from BSI publications contact the BSI Copyright & Licensing team.

Subscriptions

Our range of subscription services are designed to make using standards easier for you. For further information on our subscription products go to bsigroup.com/subscriptions.

With **British Standards Online (BSOL)** you'll have instant access to over 55,000 British and adopted European and international standards from your desktop. It's available 24/7 and is refreshed daily so you'll always be up to date.

You can keep in touch with standards developments and receive substantial discounts on the purchase price of standards, both in single copy and subscription format, by becoming a **BSI Subscribing Member**.

PLUS is an updating service exclusive to BSI Subscribing Members. You will automatically receive the latest hard copy of your standards when they're revised or replaced.

To find out more about becoming a BSI Subscribing Member and the benefits of membership, please visit bsigroup.com/shop.

With a **Multi-User Network Licence (MUNL)** you are able to host standards publications on your intranet. Licences can cover as few or as many users as you wish. With updates supplied as soon as they're available, you can be sure your documentation is current. For further information, email subscriptions@bsigroup.com.

Revisions

Our British Standards and other publications are updated by amendment or revision.

We continually improve the quality of our products and services to benefit your business. If you find an inaccuracy or ambiguity within a British Standard or other BSI publication please inform the Knowledge Centre.

Useful Contacts

Customer Services

Tel: +44 345 086 9001

Email (orders): orders@bsigroup.com

Email (enquiries): cservices@bsigroup.com

Subscriptions

Tel: +44 345 086 9001

Email: subscriptions@bsigroup.com

Knowledge Centre

Tel: +44 20 8996 7004

Email: knowledgecentre@bsigroup.com

Copyright & Licensing

Tel: +44 20 8996 7070

Email: copyright@bsigroup.com

BSI Group Headquarters

389 Chiswick High Road London W4 4AL UK