

Filters for compressed air — Test methods —

Part 2: Oil vapours

ICS 23.100.60; 71.100.20

National foreword

This British Standard is the UK implementation of ISO 12500-2:2007.

The UK participation in its preparation was entrusted to Technical Committee MCE/8, Compressors, pneumatic tools, pneumatic machines and vacuum technology.

A list of organizations represented on this committee can be obtained on request to its secretary.

This publication does not purport to include all the necessary provisions of a contract. Users are responsible for its correct application.

Compliance with a British Standard cannot confer immunity from legal obligations.

This British Standard was published under the authority of the Standards Policy and Strategy Committee on 31 July 2007

© BSI 2007

ISBN 978 0 580 53131 6

Amendments issued since publication

Amd. No.	Date	Comments

INTERNATIONAL
STANDARD

ISO
12500-2

First edition
2007-06-01

**Filters for compressed air — Test
methods —**

**Part 2:
Oil vapours**

Filtres pour air comprimé — Méthodes d'essai —

Partie 2: Vapeurs d'huile



Reference number
ISO 12500-2:2007(E)

Contents		Page
1	Scope	1
2	Normative references	1
3	Terms and definitions	1
4	Units and symbols	2
5	Reference conditions	2
6	Test requirements	3
7	Test method	4
8	Uncertainty	6
9	Test report	7
Annex A (informative) Description and application of the test equipment		8
Annex B (informative) Sample test report form		9
Bibliography		10

Foreword

ISO (the International Organization for Standardization) is a worldwide federation of national standards bodies (ISO member bodies). The work of preparing International Standards is normally carried out through ISO technical committees. Each member body interested in a subject for which a technical committee has been established has the right to be represented on that committee. International organizations, governmental and non-governmental, in liaison with ISO, also take part in the work. ISO collaborates closely with the International Electrotechnical Commission (IEC) on all matters of electrotechnical standardization.

International Standards are drafted in accordance with the rules given in the ISO/IEC Directives, Part 2.

The main task of technical committees is to prepare International Standards. Draft International Standards adopted by the technical committees are circulated to the member bodies for voting. Publication as an International Standard requires approval by at least 75 % of the member bodies casting a vote.

Attention is drawn to the possibility that some of the elements of this document may be the subject of patent rights. ISO shall not be held responsible for identifying any or all such patent rights.

ISO 12500-2 was prepared by Technical Committee ISO/TC 118, *Compressors and pneumatic tools, machines and equipment*, Subcommittee SC 4, *Quality of compressed air*.

ISO 12500 consists of the following parts, under the general title *Filters for compressed air — Test methods*:

- *Part 1: Oil aerosols*
- *Part 2: Oil vapours*
- *Part 3: Particulates*

Introduction

Oil adsorbent filters (e.g. activated carbon, etc.) are designed for the removal of oil vapours and odours from compressed air or gas streams.

The most important performance characteristics of the filter are its ability to remove hydrocarbon vapours, its total adsorptive capacity and pressure drop.

The aim of this part of ISO 12500 is to define a method and test condition by which the above characteristics can be measured and compared.

Filters for compressed air — Test methods —

Part 2: Oil vapours

1 Scope

This part of ISO 12500 specifies the test layout and test procedures required for testing hydrocarbon vapour adsorbent filters used in compressed-air systems to determine their effectiveness in removing hydrocarbon vapours. The performance characteristics to be identified are

- adsorptive capacity;
- pressure drop (Δp).

This part of ISO 12500 defines one method of presenting filter performance as hydrocarbon vapour capacity, expressed in milligrams, from results obtained under test conditions.

2 Normative references

The following referenced documents are indispensable for the application of this document. For dated references, only the edition cited applies. For undated references, the latest edition of the referenced document (including any amendments) applies.

ISO 1219-1, *Fluid power systems and components — Graphic symbols and circuit diagrams — Part 1: Graphic symbols for conventional use and data-processing applications*

ISO 2602, *Statistical interpretation of test results — Estimation of the mean — Confidence interval*

ISO 2854, *Statistical interpretation of data — Techniques of estimation and tests relating to means and variances*

ISO 5598, *Fluid power systems and components — Vocabulary*

ISO 7000, *Graphical symbols for use on equipment — Index and synopsis*

ISO 8573-1:2001, *Compressed air — Part 1: Contaminants and purity classes*

ISO 8573-6, *Compressed air — Part 6: Test methods for gaseous contaminant content*

3 Terms and definitions

For the purposes of this document, the terms and definitions given in ISO 5598 and the following apply.

3.1

activated carbon

charcoal which has an enhanced property of attracting certain gases or vapours into the pore structure of its surface layer

3.2 adsorbent
solid having the property of attracting gaseous or liquid molecules and causing them to adhere to its surface

3.3 adsorptive capacity
mass of a contaminant that can be adsorbed by tested filter

3.4 ambient temperature
temperature of the air surrounding the filter housing under test

3.5 breakthrough
point when a determined amount of the test agent is detected downstream of the adsorbent filter

3.6 equivalent rated flow
flow at which, when the test filter is operated at a 700 kPa [7 bar (e)] test pressure, an equal gas velocity to that for the device would be achieved were it to be operated at its rated pressure and flow

3.7 filter
apparatus for separation or removal of contamination from a compressed air or gas stream

3.8 pressure drop differential pressure
 Δp
difference between the inlet and outlet pressure of a component, measured under specified conditions

3.9 test agent
n-hexane vapour used to challenge the filter under test

4 Units and symbols

General use of SI units (Système international d'unités; see ISO 1000) as given throughout this part of ISO 12500 is recommended. However, in agreement with accepted practice in the pneumatic field, some non-preferred SI units, accepted by ISO, are also used.

$$1 \text{ bar} = 100\,000 \text{ Pa}$$

NOTE bar (e) is used to indicate effective pressure above atmospheric.

$$1 \text{ l (litre)} = 0,001 \text{ m}^3$$

The graphic symbols on diagrams are in accordance with ISO 1219-1 and ISO 7000.

5 Reference conditions

The reference conditions for gas volumes shall be:

- air temperature 20 °C;
- absolute air pressure 100 kPa [1 bar (a)];
- relative water vapour pressure 0.

6 Test requirements

6.1 Standard rating parameters

The standard rating parameters are as identified in Table 1.

Table 1 — Standard rating parameters

Reporting parameter	Units	Rating conditions	Maintain within actual gauge value	Instrument accuracy at test conditions
Inlet temperature	°C	20	± 5	± 2 °C
Inlet pressure	kPa [bar (e)]	700 (7)	± 10 (0,1)	± 10 kPa (± 0,1 bar) gauge reading
Ambient temperature	°C	20	± 5	± 2 °C
Test agent concentration in air ^a	mg/kg	1 000	± 50	± 0,1 %
Minimum air purity ^b	—	ISO 8573-1:2001, Class 2 2 1 ^c		
Air flow for testing	m ³ /h	100 % rated flow	± 2 %	± 4 % gauge reading
Pressure drop	Pa (mbar)	Not applicable	Not applicable	± 1 kPa (± 10 mbar) gauge reading

^a Density of air is taken as 1,18 kg/m³.

^b Minimum air purity to ensure that the filter under test is not affected by the presence of water vapour.

^c The first number represents the solid-particle classification; the second, the humidity classification; and the third, the total oil classification.

6.2 Inlet air flow

Testing of hydrocarbon vapour adsorbent filters shall be carried out at the manufacturer's equivalent rated flow.

For the testing of filters that have their maximum flow rating quoted at a pressure other than 700 kPa [7 bar (e)] the measurement for hydrocarbon vapour removal can be made using equivalent flow velocity at rated pressure identified by the manufacturer for the filter under test.

The test flow rate, $q_{V_{e,REF}}$, at reference conditions, expressed in cubic metres per second, is calculated according to Equation (1):

$$q_{V_{e,REF}} = \frac{q_{V_{n,REF}} \times \kappa_T \times p_e}{p_n} \quad (1)$$

where

$q_{V_{n,REF}}$ is rated flow rate, at reference conditions, expressed in cubic metres per hour;

p_e is absolute test pressure, expressed in kPa [bar (a)];

p_n is absolute rated pressure, expressed in kPa [bar (a)];

κ_T is the compressibility factor of air at rated pressure and 20 °C, dimensionless.

6.3 Test agent

The test agent used to challenge the adsorbent filters under investigation simulates operation with compressor oils.

The liquid *n*-hexane used as the test agent in this standard should have a purity of not less than 98 % (usually equating to a general-purpose laboratory reagent grade).

Care should be taken not to contaminate the *n*-hexane with other chemicals or particulate matter.

7 Test method

7.1 Test equipment arrangement

A schematic diagram of the test equipment is shown in Figure 1.

A description of the test equipment is given in Annex A.

7.2 Test parameters

During the period of the test all the various parameters shall be maintained within the tolerances specified in Table 1.

7.3 Determination of breakthrough concentration

Measurement of inlet/outlet challenge concentration shall be in accordance with ISO 8573-6; however iso-kinetic sampling is not required.

Breakthrough of the test agent occurs when the downstream concentration of test agent reaches 1 mg/kg.

A suitable instrument calibrated with the test agent in accordance with manufacturers' instructions shall be used to measure the test agent concentration, e.g. flame-ionization detector or infra-red analyser.

7.4 Test duration

Measure the time from the introduction of the vapour to the filter under test until breakthrough is detected. At least three examples of each model shall be tested and the results averaged.

7.5 Differential pressure

Measure and record the pressure drop across the filter under test.

7.6 Calculation of adsorbed test agent

The mass, expressed in milligrams, of test agent, M_{TA} , adsorbed by the test filter shall be calculated as given in Equation (2):

$$M_{TA} = w_{TA,i} \times q_{air} \times t \times 1,18 \quad (2)$$

where

$w_{TA,i}$ is inlet concentration of the test agent, expressed in milligrams per kilogram;

q_{air} is air flow rate used during test, expressed in cubic metres per hour;

t is the time to achieve the breakthrough of the activated carbon element under test, expressed in hours

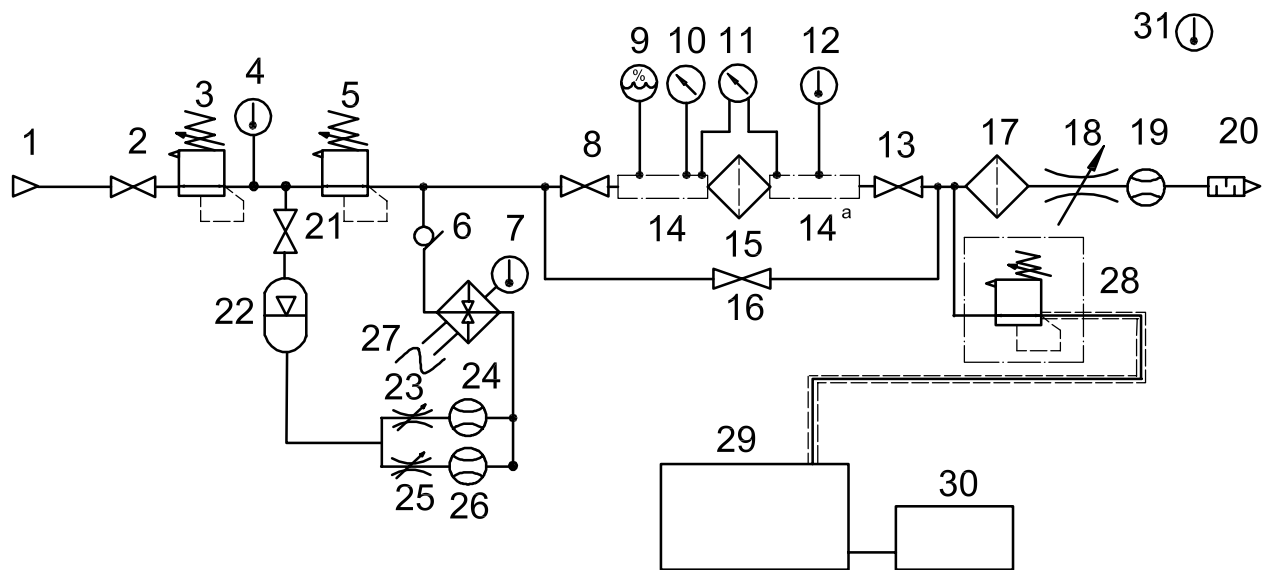

Key

- 1 compressed air supply
- 2 full-flow ball valve
- 3 pressure regulator
- 4 pressure sensing/measuring
- 5 pressure regulator
- 6 non-return valve
- 7 temperature sensing/measuring
- 8 full-flow ball valve
- 9 dewpoint sensing/measuring
- 10 pressure sensing/measuring
- 11 pressure differential gauge
- 12 temperature sensing/measuring
- 13 full-flow ball valve
- 14 pressure measuring tube
- 15 filter under test
- 16 by-pass full-flow ball valve
- 17 activated carbon filter (with sufficient capacity to protect against release of n-hexane)
- 18 multi-turn flow control valve
- 19 flow sensing/measuring
- 20 silencer
- 21 full-flow ball valve
- 22 test agent reservoir
- 23 multi-turn flow control valve (coarse flow)
- 24 flow sensing/measuring
- 25 multi-turn flow control valve (fine flow)
- 26 flow sensing/measuring
- 27 evaporator
- 28 heated pressure regulator and line to 29
- 29 hydrocarbon vapour detector
- 30 data recorder
- 31 ambient temperature sensing/measuring

^a Details of the construction of the measuring tubes are given in ISO 7183.

Figure 1 — Typical layout of test equipment

7.7 Test procedure

Test procedure shall be done in the following order.

- a) Stabilize all test equipment at constant operating temperature, pressure and flow conditions. Commence data recording.
- b) Establish the background level of ambient methane by using the hydrocarbon vapour detector (HVD) (typically < 5 mg/kg). This level can either be zeroed off on the HVD or added to the breakthrough concentration for the time to breakthrough measurement.
- c) Establish the level and stability of the upstream test agent concentration by adjustment of the liquid-feed control valves on the evaporator apparatus while checking the concentration with the HVD with the test filter bypass line open and the valves on both sides of the test filter closed.
- d) Install the test filter, open the inlet valve to the test filter followed by the outlet valve and simultaneously close the bypass valve. The downstream concentration measured by the HVD should return to a level less than the specified breakthrough concentration. Record the time at which this level is reached.
- e) Record the test filter differential pressure.
- f) Monitor the downstream concentration with the HVD until such time as the measured value exceeds the specified breakthrough concentration. The exact time to breakthrough can be determined from the trend data which have been recorded by the data recorder.
- g) Close the evaporator supply valves and isolate the evaporator from the main line. Open the bypass valve and close both test filter isolation valves.
- h) Following the conclusion of the test, all air-supply valves should be closed and the pressure within the test apparatus allowed to safely decay to 0 kPa [0 bar (e)].

8 Uncertainty

NOTE A calculation of the probable error, according to this clause is not always necessary.

Due to the very nature of physical measurements, it is impossible to measure a physical quantity without error or, in fact, to determine the true error of any one particular measurement. However, if the conditions of the measurement are sufficiently well known, it is possible to estimate or calculate a characteristic deviation of the measured value from the true value, such that it can be asserted with a certain degree of confidence that the true error is less than the said deviation. The value of such a deviation (normally a 95 % confidence limit) constitutes a criterion for the accuracy of the particular measurement.

It is assumed that compensation can be made by corrections for all systematic errors that can occur in the measurement of the individual quantities measured and of the characteristics of the air. A further assumption is that the confidence limits in errors in reading and integration errors are negligible if the number of readings is sufficient.

The (small) systematic errors that can occur are covered by the inaccuracy of measurements.

Quality classifications and limits of error are often invoked for ascertaining the uncertainty of individual measurement because apart from the exceptions (e.g. electrical transducers), they constitute only a fraction of the quality class or the limit of error.

The information about ascertaining the uncertainty of the measurement of the individual quantities measured and on the confidence limits of the gas properties are approximations. These approximations can be improved only at a disproportionate expense according to ISO 2602 and ISO 2854.

9 Test report

9.1 Statement

Performance data shall be stated at reference conditions and as a minimum shall include at least the following data in Table 1.

9.2 Technical data

Technical data presentation shall include at least the following:

- statement that the data was obtained during testing in accordance with ISO 12500-2;
- model number of filter housing;
- model number of filter element;
- average mass of test agent adsorbed;
- pressure drop (Δp).

When quoting performance characteristics, including expected life calculations, the results shall include those obtained under test conditions.

A sample test report form is provided in Annex B.

Annex A (informative)

Description and application of the test equipment

A.1 Piping

The piping should have smooth internal bores, should be easy to clean, should be resistant to the test agent and should be constructed of stainless steel. All parts, with particular attention to non-conductive parts, should be grounded to prevent static build-up.

Soft rubber and plastic pipe should be avoided as this can be permeable to the test-agent vapour and can become contaminated, resulting in high background contaminant levels building up in the test rig.

A.2 Shut off valves

These shall be of a full-flow ball valve design. They shall be constructed of brass or stainless steel with polytetrafluoroethylene (PTFE) seats.

A.3 Flow-control valves

These shall be of brass or stainless steel construction. Generally, needle- or gate-valve designs give the smoothest flow control.

A.4 Evaporator

The evaporator consists of an electrically heated and temperature-controlled heating jacket around a thick-walled pipe capable of heating the liquid test agent above 50 °C.

A.5 Downstream of the evaporator

The measuring equipment used downstream of the evaporator shall be resistant to high levels of test-agent vapour.

A.6 Data recorder

The data recorder can be used to produce a hard-copy documentation of the test duration and also, if possible, to record all the other various parameters during each test.

A.7 Flow meter

The test-rig flow meter should be able to take into account variations in test-rig air temperature and pressure for ultimate accuracy.

Annex B (informative)

Sample test report form

Test date	
Test facility	
Location	
Contact	
Product tested	
Manufacturer	
Filter housing model number	
Filter element model number	
Rated flow	
Test agent	<i>n</i> -hexane

Standard rating parameters and results

Reported parameters	Unit	Rated conditions	Test 1	Test 2	Test 3	Results (mean)
Inlet temperature	°C	20 ± 5				
Inlet pressure	kPa [bar (e)]	7 ± 0,1				
Ambient temperature	°C	20 ± 5				
Air flow for breakthrough test	m ³ /h					
Inlet test agent concentration	mg/kg					
Time to breakthrough	h					
Mass of test agent adsorbed	mg					
Pressure drop (Δp)	Pa (mbar)					
Notes:						
Tested by:						
Signature (tester):				Date:		
Witness (manufacturer or other):				Date:		

Bibliography

- [1] ISO 1000, *SI units and recommendations for the use of their multiples and of certain other units*
- [2] ISO 7183¹⁾, *Compressed-air dryers — Specifications and testing*

1) To be published. (Revision of ISO 7183:1986)

BSI — British Standards Institution

BSI is the independent national body responsible for preparing British Standards. It presents the UK view on standards in Europe and at the international level. It is incorporated by Royal Charter.

Revisions

British Standards are updated by amendment or revision. Users of British Standards should make sure that they possess the latest amendments or editions.

It is the constant aim of BSI to improve the quality of our products and services. We would be grateful if anyone finding an inaccuracy or ambiguity while using this British Standard would inform the Secretary of the technical committee responsible, the identity of which can be found on the inside front cover.
Tel: +44 (0)20 8996 9000. Fax: +44 (0)20 8996 7400.

BSI offers members an individual updating service called PLUS which ensures that subscribers automatically receive the latest editions of standards.

Buying standards

Orders for all BSI, international and foreign standards publications should be addressed to Customer Services. Tel: +44 (0)20 8996 9001.
Fax: +44 (0)20 8996 7001. Email: orders@bsi-global.com. Standards are also available from the BSI website at <http://www.bsi-global.com>.

In response to orders for international standards, it is BSI policy to supply the BSI implementation of those that have been published as British Standards, unless otherwise requested.

Information on standards

BSI provides a wide range of information on national, European and international standards through its Library and its Technical Help to Exporters Service. Various BSI electronic information services are also available which give details on all its products and services. Contact the Information Centre.
Tel: +44 (0)20 8996 7111. Fax: +44 (0)20 8996 7048. Email: info@bsi-global.com.

Subscribing members of BSI are kept up to date with standards developments and receive substantial discounts on the purchase price of standards. For details of these and other benefits contact Membership Administration.
Tel: +44 (0)20 8996 7002. Fax: +44 (0)20 8996 7001.
Email: membership@bsi-global.com.

Information regarding online access to British Standards via British Standards Online can be found at <http://www.bsi-global.com/bsonline>.

Further information about BSI is available on the BSI website at <http://www.bsi-global.com>.

Copyright

Copyright subsists in all BSI publications. BSI also holds the copyright, in the UK, of the publications of the international standardization bodies. Except as permitted under the Copyright, Designs and Patents Act 1988 no extract may be reproduced, stored in a retrieval system or transmitted in any form or by any means – electronic, photocopying, recording or otherwise – without prior written permission from BSI.

This does not preclude the free use, in the course of implementing the standard, of necessary details such as symbols, and size, type or grade designations. If these details are to be used for any other purpose than implementation then the prior written permission of BSI must be obtained.

Details and advice can be obtained from the Copyright & Licensing Manager.
Tel: +44 (0)20 8996 7070. Fax: +44 (0)20 8996 7553.
Email: copyright@bsi-global.com.