

BS ISO 12490:2011



BSI Standards Publication

# Petroleum and natural gas industries — Mechanical integrity and sizing of actuators and mounting kits for pipeline valves

**bsi.**

...making excellence a habit.™

**National foreword**

This British Standard is the UK implementation of ISO 12490:2011.

The UK participation in its preparation was entrusted to Technical Committee PSE/17/2, Transmission pipelines.

A list of organizations represented on this committee can be obtained on request to its secretary.

This publication does not purport to include all the necessary provisions of a contract. Users are responsible for its correct application.

© BSI 2011

ISBN 978 0 580 64357 6

ICS 75.200

**Compliance with a British Standard cannot confer immunity from legal obligations.**

This British Standard was published under the authority of the Standards Policy and Strategy Committee on 30 September 2011.

**Amendments issued since publication**

| Date | Text affected |
|------|---------------|
|------|---------------|

---

---

---

**Petroleum and natural gas industries —  
Mechanical integrity and sizing of  
actuators and mounting kits for pipeline  
valves**

*Industries du pétrole et du gaz naturel — Intégrité mécanique et  
dimensionnement des motorisations et éléments de montage des  
vannes de conduites*





**COPYRIGHT PROTECTED DOCUMENT**

© ISO 2011

All rights reserved. Unless otherwise specified, no part of this publication may be reproduced or utilized in any form or by any means, electronic or mechanical, including photocopying and microfilm, without permission in writing from either ISO at the address below or ISO's member body in the country of the requester.

ISO copyright office  
Case postale 56 • CH-1211 Geneva 20  
Tel. + 41 22 749 01 11  
Fax + 41 22 749 09 47  
E-mail [copyright@iso.org](mailto:copyright@iso.org)  
Web [www.iso.org](http://www.iso.org)

Published in Switzerland

# Contents

Page

|  |           |
|--|-----------|
| Foreword .....   | v         |
| Introduction.....  | vi        |
| <b>1</b> <b>Scope</b> .....  | <b>1</b>  |
| <b>2</b> <b>Conformance</b> .....  | <b>1</b>  |
| 2.1 <b>Units of measurement</b> .....  | <b>1</b>  |
| 2.2 <b>Rounding</b> .....  | <b>1</b>  |
| 2.3 <b>Compliance with this International Standard</b> .....                                   | <b>1</b>  |
| <b>3</b> <b>Normative references</b> .....   | <b>2</b>  |
| <b>4</b> <b>Terms and definitions</b> .....  | <b>3</b>  |
| <b>5</b> <b>Symbols and abbreviated terms</b> .....  | <b>6</b>  |
| 5.1 <b>Symbols</b> .....   | <b>6</b>  |
| 5.2 <b>Abbreviated terms</b> .....   | <b>6</b>  |
| <b>6</b> <b>Actuator types and configurations</b> .....  | <b>7</b>  |
| 6.1 <b>General</b> .....   | <b>7</b>  |
| 6.2 <b>Actuator types</b> .....  | <b>7</b>  |
| 6.3 <b>Actuator configuration</b> .....  | <b>20</b> |
| 6.4 <b>Action on loss of supply energy</b> .....   | <b>21</b> |
| <b>7</b> <b>Design</b> .....   | <b>21</b> |
| 7.1 <b>General</b> .....   | <b>21</b> |
| 7.2 <b>Pressure-containing parts</b> .....   | <b>23</b> |
| 7.3 <b>Bolting and tie rod design</b> .....  | <b>24</b> |
| 7.4 <b>Mechanically loaded parts</b> .....   | <b>24</b> |
| 7.5 <b>Springs and modules</b> .....   | <b>24</b> |
| 7.6 <b>Mounting kit</b> .....  | <b>24</b> |
| 7.7 <b>Stem extensions</b> .....   | <b>25</b> |
| 7.8 <b>Lifting</b> .....   | <b>25</b> |
| 7.9 <b>Handwheels and levers for manual override</b> .....                                     | <b>25</b> |
| 7.10 <b>Locking devices</b> .....  | <b>26</b> |
| 7.11 <b>Position indicators</b> .....  | <b>26</b> |
| 7.12 <b>Travel stops</b> .....   | <b>26</b> |
| 7.13 <b>Orientation</b> .....  | <b>26</b> |
| 7.14 <b>Sealing</b> .....  | <b>26</b> |
| 7.15 <b>Over-pressure protection</b> .....   | <b>26</b> |
| 7.16 <b>Design documents</b> .....   | <b>26</b> |
| <b>8</b> <b>Sizing</b> .....   | <b>26</b> |
| 8.1 <b>Information required for actuator sizing</b> .....                                      | <b>26</b> |
| 8.2 <b>Sizing method</b> .....   | <b>28</b> |
| <b>9</b> <b>Instrumentation/regulation</b> .....   | <b>28</b> |
| 9.1 <b>Torque limiting settings — Electric actuators</b> .....                                 | <b>28</b> |
| 9.2 <b>Torque/thrust limiting controls — Pneumatic/hydraulic actuators</b> .....               | <b>29</b> |
| <b>10</b> <b>Materials</b> .....   | <b>29</b> |
| 10.1 <b>Material specification</b> .....   | <b>29</b> |
| 10.2 <b>Service compatibility</b> .....  | <b>29</b> |
| 10.3 <b>Composition limits</b> .....   | <b>29</b> |
| 10.4 <b>Toughness test requirements for pressure-containing parts</b> .....                    | <b>30</b> |
| 10.5 <b>Bolting for pressure-containing, mechanically loaded parts and mounting kits</b> ..... | <b>31</b> |
| 10.6 <b>Mechanically loaded parts</b> .....  | <b>31</b> |

|              |  |    |
|--------------|--|----|
| 10.7         | Sour service .....                                       | 31 |
| 11           | Welding .....  | 31 |
| 11.1         | Welding of pressure-containing parts .....               | 31 |
| 11.2         | Structural welding.....                                  | 31 |
| 11.3         | Impact testing.....                                      | 32 |
| 11.4         | Hardness testing.....                                    | 33 |
| 11.5         | Repair.....  | 33 |
| 12           | Quality control.....                                     | 33 |
| 12.1         | NDE requirements.....                                    | 33 |
| 12.2         | Measuring and test equipment.....                        | 34 |
| 12.3         | Qualification of inspection and test personnel .....     | 34 |
| 12.4         | NDE of repairs .....                                     | 35 |
| 12.5         | Visual inspection of castings .....                      | 35 |
| 13           | Testing .....  | 35 |
| 13.1         | General.....   | 35 |
| 13.2         | Shell test .....   | 35 |
| 13.3         | Piston seal test.....                                    | 36 |
| 13.4         | Torque/thrust test — Pneumatic/hydraulic actuators ..... | 36 |
| 13.5         | Testing of electric actuators.....                       | 36 |
| 13.6         | Actuator functional test .....                           | 37 |
| 14           | Surface protection .....                                 | 37 |
| 15           | Marking .....  | 38 |
| 16           | Preparation for shipment .....                           | 38 |
| 17           | Documentation.....                                       | 39 |
| Annex A      | (informative) Supplementary test requirements.....       | 40 |
| Annex B      | (informative) Optional documentation.....                | 41 |
| Annex C      | (informative) Purchasing guidelines.....                 | 42 |
| Annex D      | (normative) Record retention .....                       | 45 |
| Annex E      | (informative) Typical torque/thrust curves.....          | 46 |
| Bibliography | .....  | 51 |

## Foreword

ISO (the International Organization for Standardization) is a worldwide federation of national standards bodies (ISO member bodies). The work of preparing International Standards is normally carried out through ISO technical committees. Each member body interested in a subject for which a technical committee has been established has the right to be represented on that committee. International organizations, governmental and non-governmental, in liaison with ISO, also take part in the work. ISO collaborates closely with the International Electrotechnical Commission (IEC) on all matters of electrotechnical standardization.

International Standards are drafted in accordance with the rules given in the ISO/IEC Directives, Part 2.

The main task of technical committees is to prepare International Standards. Draft International Standards adopted by the technical committees are circulated to the member bodies for voting. Publication as an International Standard requires approval by at least 75 % of the member bodies casting a vote.

Attention is drawn to the possibility that some of the elements of this document may be the subject of patent rights. ISO shall not be held responsible for identifying any or all such patent rights.

ISO 12490 was prepared by Technical Committee ISO/TC 67, *Materials, equipment and offshore structures for petroleum, petrochemical and natural gas industries*, Subcommittee SC 2, *Pipeline transportation systems*.

## Introduction

It is necessary that users of this International Standard be aware that further or differing requirements can be needed for individual applications. This International Standard is not intended to inhibit a vendor from offering, or the purchaser from accepting, alternative equipment or engineering solutions for the individual application. This can be particularly applicable where there is innovative or developing technology. Where an alternative is offered, it is the responsibility of the vendor to identify any variations from this International Standard and provide details.



# Petroleum and natural gas industries — Mechanical integrity and sizing of actuators and mounting kits for pipeline valves

## 1 Scope

This International Standard defines the requirements for mechanical integrity and sizing of actuators used on valves manufactured under ISO 14313 and API Specification 6D.

This International Standard is applicable to all types of electric, pneumatic and hydraulic actuators, inclusive of mounting kit, installed on pipeline valves.

This International Standard is not applicable to actuators installed on control valves, valves being used for regulation, valves in sub-sea service, handheld powered devices, stand-alone manually operated gearboxes, instrument tubing and associated fittings and actuator control equipment.

## 2 Conformance

### 2.1 Units of measurement

In this International Standard, data are expressed in both SI units and USC units. For a specific order item, unless otherwise stated, only one system of units shall be used, without combining data expressed in the other system.

For data expressed in SI units, a comma is used as the decimal separator and a space is used as the thousands separator. For data expressed in USC units, a dot (on the line) is used as the decimal separator and a comma is used as the thousands separator.

### 2.2 Rounding

Unless otherwise stated in this International Standard, to determine conformance with the specified requirements, observed or calculated values shall be rounded to the nearest unit in the last right-hand place of figures used in expressing the limiting value, in accordance with ISO 80000-1:2009.

### 2.3 Compliance with this International Standard

A quality system should be applied to assist compliance with the requirements of this International Standard.

NOTE ISO/TS 29001 gives sector-specific guidance on quality management systems.

The manufacturer shall be responsible for complying with all of the applicable requirements of this International Standard. It shall be permissible for the purchaser to make any investigation necessary in order to be assured of compliance by the manufacturer and to reject any material that does not comply.

### 3 Normative references

The following referenced documents are indispensable for the application of this document. For dated references, only the edition cited applies. For undated references, the latest edition of the referenced document (including any amendments) applies.

ISO 148-1, *Metallic materials — Charpy pendulum impact test — Part 1: Test method*

ISO 4406:1999, *Hydraulic fluid power — Fluids — Method for coding the level of contamination by solid particles*

ISO 5210, *Industrial valves — Multi-turn valve actuator attachments*

ISO 5211, *Industrial valves — Part-turn actuator attachments*

ISO 9606-1, *Approval testing of welders — Fusion welding — Part 1: Steels*

ISO 9712, *Non-destructive testing — Qualification and certification of NDT personnel — General principles*

ISO 10474, *Steel and steel products — Inspection documents*

ISO 14313:2007, *Petroleum and natural gas industries — Pipeline transportation systems — Pipeline valves*

ISO 15156 (all parts), *Petroleum and natural gas industries — Materials for use in H<sub>2</sub>S-containing environments in oil and gas production*

ISO 15607, *Specification and qualification of welding procedures for metallic materials — General rules*

ISO 15609 (all parts), *Specification and qualification of welding procedures for metallic materials — Welding procedure specification*

ISO 15614-1, *Specification and qualification of welding procedures for metallic materials — Welding procedure test — Part 1: Arc and gas welding of steels and arc welding of nickel and nickel alloys*

ISO 80000-1:2009, *Qualities and units — Part 1: General*

IEC 60529, *Degrees of protection provided by enclosures (IP Code)*

ASME Boiler and Pressure Vessel Code, Section VIII, Division 1, *Rules for Construction of Pressure Vessels*<sup>1)</sup>

ASME Boiler and Pressure Vessel Code, Section VIII:2004, Division 2, Alternative Rules, *Rules for Construction of Pressure Vessels*

ASME Boiler and Pressure Vessel Code, Section IX, *Welding and Brazing Qualifications*

ASNT SNT-TC-1A<sup>2)</sup>, Recommended Practice No. SNT-TC-1A, *Non-Destructive Testing*

ASTM A320/A320M<sup>3)</sup>, *Standard Specification for Alloy-Steel and Stainless Steel Bolting Materials for Low-Temperature Service*

ASTM A370, *Standard Test Methods and Definitions for Mechanical Testing of Steel Products*

ANSI/AWS D1.1/D1.1M<sup>4)</sup>, *Structural Welding Code — Steel*

---

1) American Society of Mechanical Engineers International, 345 East 47th Street, New York, NY 10017-2392, USA.

2) American Society of Non-Destructive Testing, P.O. Box 28518, 1711 Arlingate Lane, Columbus, OH 43228-0518, USA.

3) ASTM International, 100 Barr Harbor Drive, West Conshohocken, PA 19428-2959, USA.

AWS QC1, *Standard for AWS Certification of Welding Inspectors*

EN 287-1<sup>5)</sup>, *Qualification test of welders — Fusion welding — Part 1: Steels*

EN 473, *Non-destructive testing — Qualification and certification of NDT personnel — General principles*

EN 10204, *Metallic products — Types of inspection documents*

EN 12516-1, *Industrial valves — Shell design strength — Part 1: Tabulation method for steel valve shells*

EN 12516-2, *Industrial valves — Shell design strength — Part 2: Calculation method for steel valve shells*

EN 13445-3, *Unfired pressure vessels — Part 3: Design*

MSS SP-55, *Quality Standard for Steel Castings for Valves, Flanges and Fittings and Other Piping Components — Visual Method for Evaluation of Surface Irregularities*

## 4 Terms and definitions

For the purposes of this document, the following terms and definitions apply.

### 4.1

#### **actuator**

electrically, pneumatically or hydraulically powered device bolted or otherwise attached to the valve for the purpose of applying torque or thrust to open and close a valve

### 4.2

#### **actuator, linear**

actuator that transmits thrust to the valve for a defined linear stroke

### 4.3

#### **actuator, multi-turn**

actuator that transmits torque to the valve for a rotation of more than one revolution

### 4.4

#### **actuator, part-turn**

actuator that transmits torque to the valve for a rotation of one revolution or less

### 4.5

#### **breakaway thrust**

#### **breakaway torque**

maximum thrust or torque required to operate a valve at maximum pressure differential

[ISO 14313]

### 4.6

#### **by agreement**

agreed between the manufacturer and/or supplier and/or purchaser

### 4.7

#### **coupling**

driven component (drive adapter, drive tube, drive shaft) that allows transmission of torque and/or thrust from an actuator driving component to the valve shaft/stem

---

4) The American Welding Society, 550 NW LeJeune Road, Miami, FL 33126, USA.

5) CEN, European Committee for Standardization, Central Secretariat, Rue de Stassart 36, B-1050 Brussels, Belgium.

**4.8  
cycle**

continuous movement of the valve obturator from the fully closed position to the fully open position and back to the fully closed position, or vice versa

**4.9  
drive train**

all parts of a valve drive between the operator and the obturator, including the obturator but excluding the operator

[ISO 14313]

**4.10  
intermediate support**

mechanical component (bracket, spool, adapter flange) that allows the attachment between a valve and actuator

**4.11  
mechanically loaded parts**

actuator parts that are designed to provide the generation and/or transmission of torque or thrust

**4.12  
maximum allowable stem torque/thrust  
MAST**

maximum torque/thrust that it is permissible to apply to the valve drive train without risk of damage, as defined by the valve manufacturer/supplier

**4.13  
mounting kit**

components that may be comprised of combinations of the following: intermediate support, coupling, drive key(s), dowel pin and bolting

**4.14  
pitch circle diameter  
PCD**

diameter of a circle on which a pattern of holes, either threaded or through-machined, is arranged, commonly used for the purpose of fastening two mating components together

**4.15  
pressure-containing parts**

parts whose failure to function as intended results in a release of contained fluid into the environment

[ISO 14313]

**4.16  
pressure, design**

pressure defined for the design of the actuator pressure-containing parts, as defined by the actuator manufacturer

**4.17  
pressure, maximum operating**

maximum available pressure to supply at the actuator pressure port, as defined by the actuator manufacturer/supplier

NOTE This is the pressure that generates the torque/thrust used to design the mounting kit.

**4.18**

**pressure, maximum rated**

maximum pressure permissible in the pressure-containing parts in their normal operating condition and which is used to generate design torque/thrust

NOTE This is the pressure that generates the torque/thrust and is used to design the mechanically loaded parts of the actuator.

**4.19**

**pressure, maximum supply**

maximum available pressure to supply at the actuator, as defined by the purchaser

**4.20**

**pressure, minimum operating**

minimum required pressure to supply at the actuator pressure port, as defined by the actuator manufacturer/supplier

**4.21**

**pressure, minimum supply**

minimum available pressure to supply at the actuator, as defined by the purchaser

**4.22**

**reduced stroke actuator**

actuator with suitable travel stops that can be used to provide a movement to a predetermined position within the actuator stroke

**4.23**

**stall torque**

maximum torque/thrust that an electric actuator develops when the motor is energised and the output drive is locked

NOTE This is the torque used to design the mechanically loaded parts of the actuator.

**4.24**

**stem**

part that connects the obturator to the operator and which can consist of one or more components

[ISO 14313]

**4.25**

**stroke**

movement of the valve obturator from the fully closed position to the fully open position, or vice versa

**4.26**

**supplier**

manufacturer or third-party supplier of the actuator or the actuated valve assembly

**4.27**

**temperature, maximum design**

maximum temperature at which the actuator is capable of operating, as defined by the actuator manufacturer

**4.28**

**temperature, maximum operating**

maximum temperature at which the actuator is required to operate, as defined by the purchaser

NOTE Operating temperature can be influenced by ambient temperature.

**4.29**

**temperature, minimum design**

minimum temperature at which the actuator is capable of operating, as defined by the actuator manufacturer

**4.30**  
**temperature, minimum operating**

minimum temperature at which the actuator is required to operate, as defined by the purchaser

NOTE Operating temperature can be influenced by ambient temperature.

**4.31**  
**torque/thrust, design**

highest torque/thrust of an actuator at maximum spring force, maximum supply voltage, or maximum rated pressure with torque/thrust-limiting or pressure-reducing protection devices de-activated, which is used to design mechanically loaded parts

**4.32**  
**torque/thrust, maximum**

highest torque/thrust of an actuator at specified voltage/pressure with torque/thrust-limiting or pressure-reducing protection devices active, which is used for the design of the mounting kit

**4.33**  
**unless otherwise agreed**

requirements of the standard shall apply, unless the manufacturer and purchaser agree on a deviation

[ISO 14313]

**4.34**  
**unless otherwise specified**

requirements of the standard shall apply, unless the purchaser specifies otherwise

[ISO 14313]

**4.35**  
**voltage, maximum supply**

maximum available voltage to be supplied at the actuator

NOTE This is the voltage used to design the mechanically loaded parts.

**4.36**  
**voltage, minimum supply**

minimum available voltage to be supplied at the actuator

## 5 Symbols and abbreviated terms

### 5.1 Symbols

$S_m$  design stress intensity

$t$  thickness

### 5.2 Abbreviated terms

BM base metal

BPVC Boiler and Pressure Vessel Code

CE carbon equivalent

HAZ heat-affected zone

HBW Brinell hardness, tungsten ball indenter

|      |                                  |
|------|----------------------------------|
| HRC  | Rockwell C hardness              |
| HV   | Vickers hardness                 |
| MT   | magnetic-particle testing        |
| NDE  | non-destructive examination      |
| PQR  | procedure qualification record   |
| PT   | penetrant testing                |
| PWHT | post-weld heat treatment         |
| RT   | radiographic testing             |
| SMYS | specified minimum yield strength |
| USC  | United States customary          |
| UT   | ultrasonic testing               |
| WM   | weld metal                       |
| WPQ  | welder performance qualification |
| WPS  | weld procedure specification     |

## 6 Actuator types and configurations

### 6.1 General

Actuators shall be part-turn, multi-turn or linear in action. Part-turn actuators shall be capable of withstanding torsional forces. Multi-turn actuators shall be capable of withstanding torsional forces, and shall also be capable of withstanding axial thrust if specified. Linear actuators shall be capable of withstanding axial thrust.

For reduced stroke actuators, i.e. an actuator that prevents the valve from reaching its fully open or fully closed position, the stroke range shall be specified by the purchaser.

NOTE Some typical torque/thrust characteristics are shown in Annex E.

### 6.2 Actuator types

#### 6.2.1 Electric

Typical configurations for electric actuators are shown, for illustration purposes only, in Figures 1 to 4.

Electric actuators shall be self-contained units, typically comprised of an electric motor, reduction gearing, limit and/or torque switches, handwheel for manual override, and a motor control package, which may be integral or external to the actuator.

Electric actuators shall be powered from either an AC or DC electrical source, which shall be specified by the purchaser. The output of electric actuators shall be part-turn, multi-turn or linear in action.

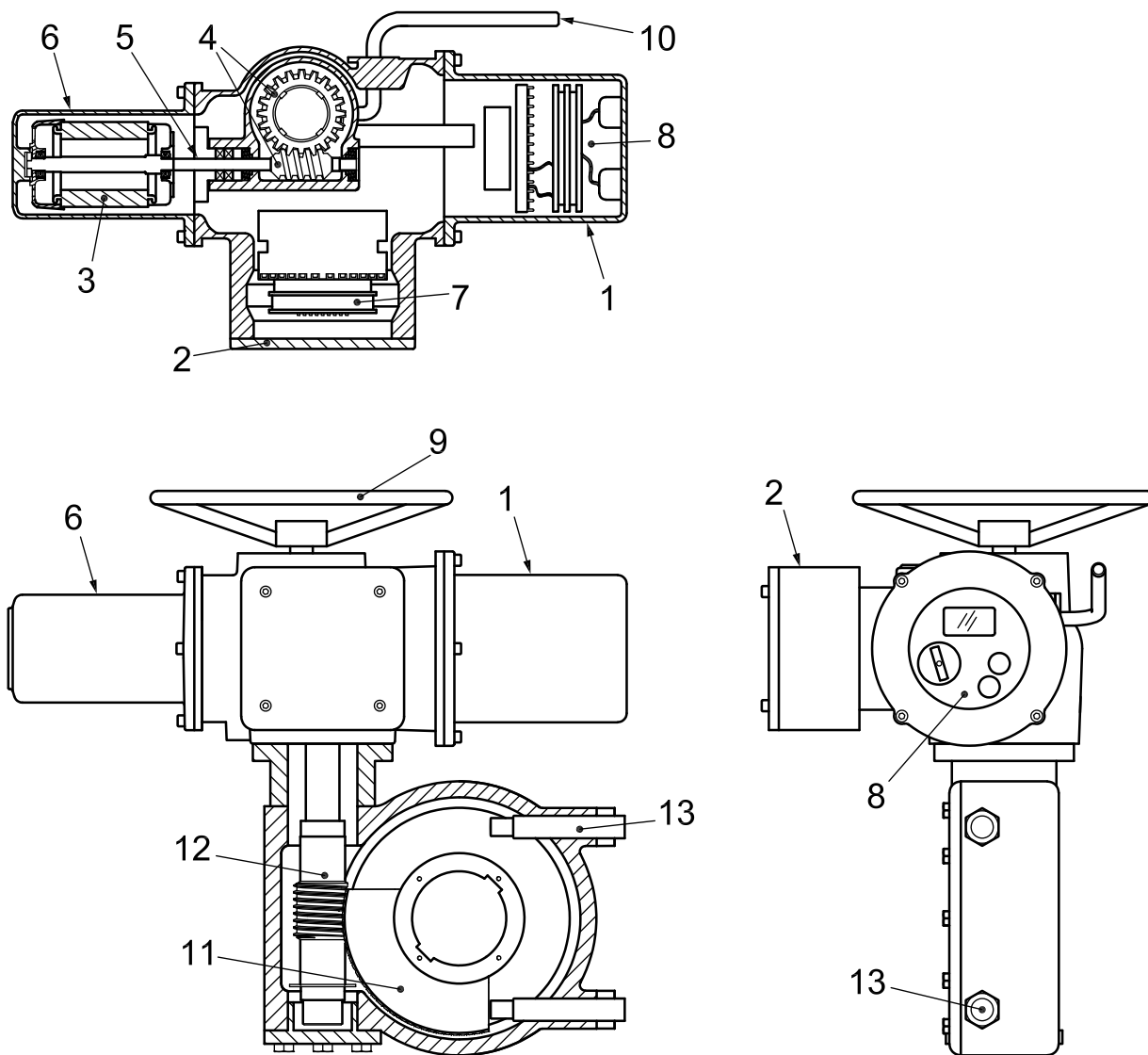

**Key**

- 1 control board housing
- 2 terminal board housing
- 3 electric motor
- 4 reduction gear
- 5 motor shaft
- 6 motor housing
- 7 terminal block
- 8 local control unit
- 9 manual override
- 10 declutch lever
- 11 part-turn gear
- 12 gearbox input shaft
- 13 stop bolt

**Figure 1 — Electric actuator, part-turn with reduction, double-acting**



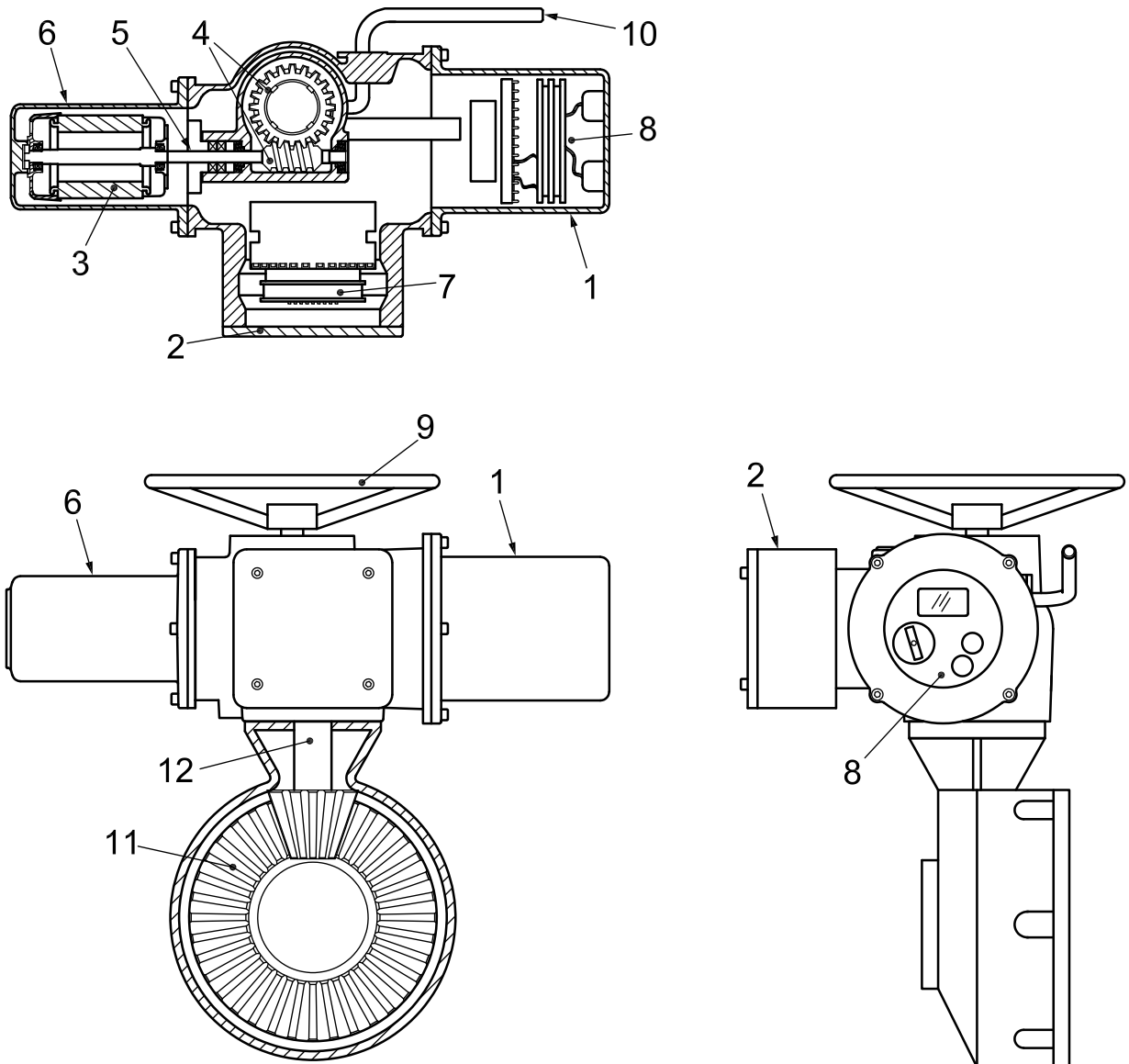

**Key**

- 1 control board housing
- 2 terminal board housing
- 3 electric motor
- 4 reduction gear
- 5 motor shaft
- 6 motor housing
- 7 terminal block
- 8 local control unit
- 9 manual override
- 10 declutch lever
- 11 multi-turn gear
- 12 gearbox input shaft

**Figure 2 — Electric actuator, multi-turn with reduction, double-acting**

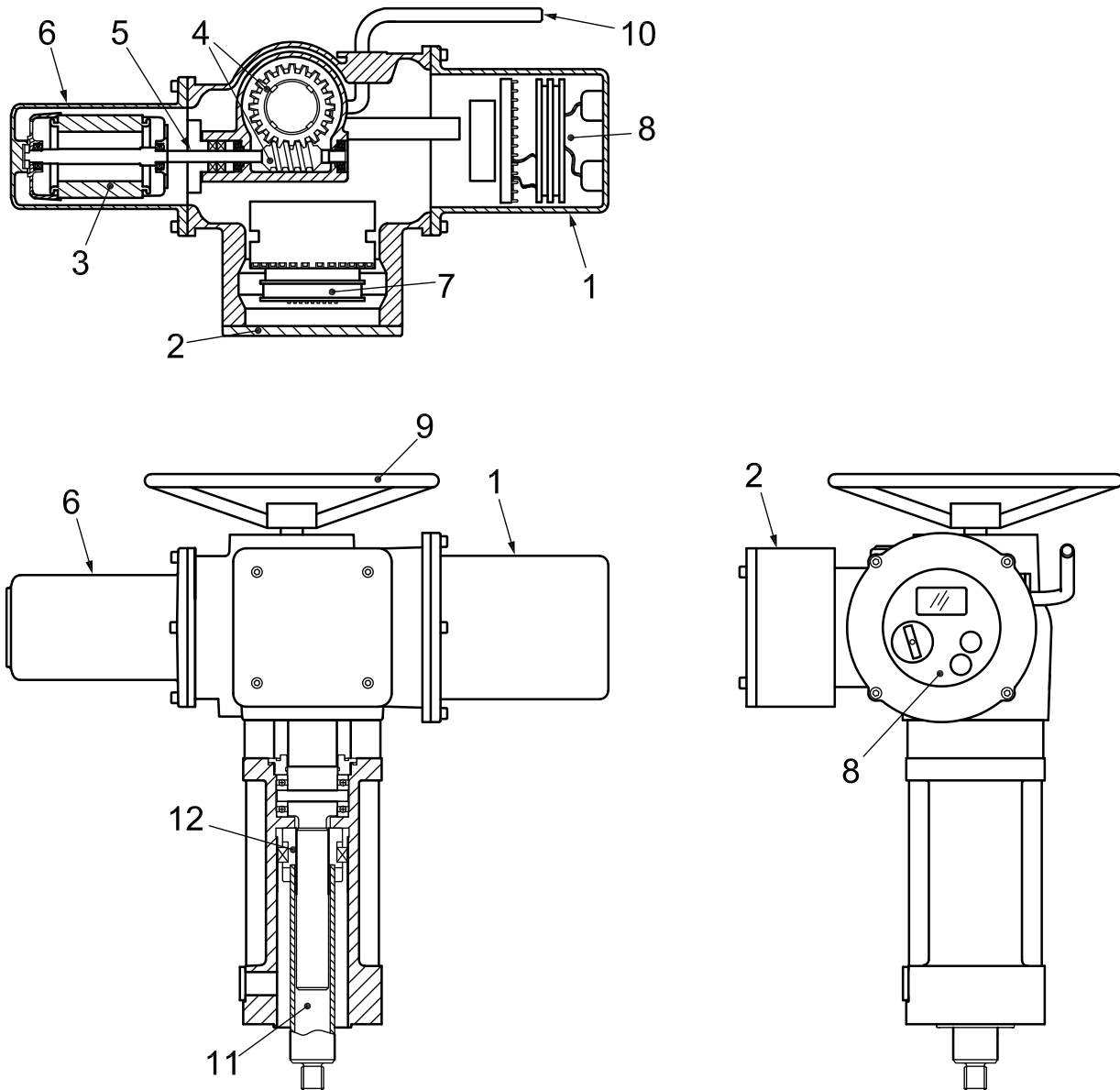

**Key**

- 1 control board housing
- 2 terminal board housing
- 3 electric motor
- 4 reduction gear
- 5 motor shaft
- 6 motor housing
- 7 terminal block
- 8 local control unit
- 9 manual override
- 10 declutch lever
- 11 linear motion shaft
- 12 thrust nut

**Figure 3 — Electric actuator, linear with reduction, double-acting**

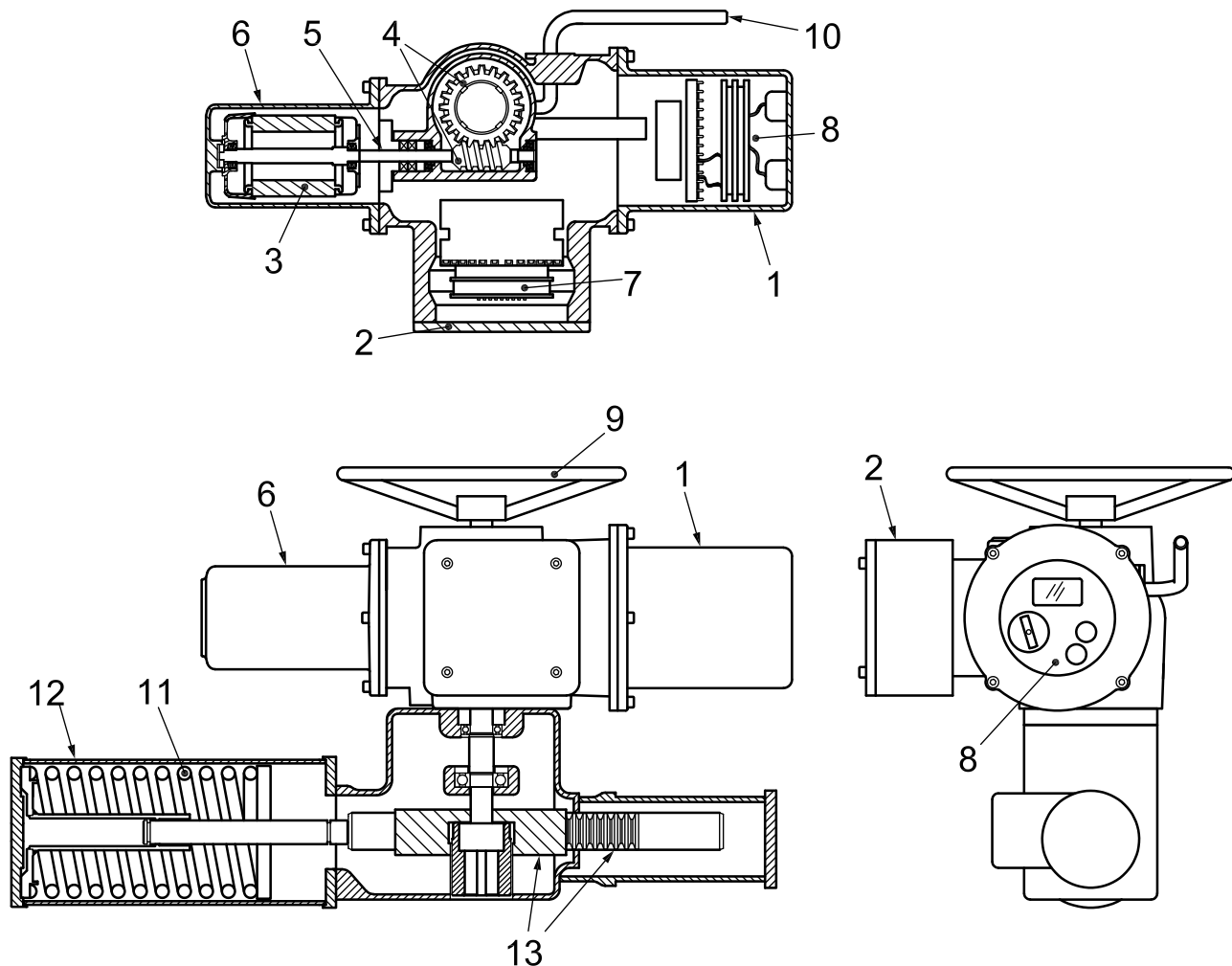

**Key**

- 1 control board housing
- 2 terminal board housing
- 3 electric motor
- 4 reduction gear
- 5 motor shaft
- 6 motor housing
- 7 terminal block
- 8 local control unit
- 9 manual override
- 10 declutch lever
- 11 spring
- 12 spring cartridge
- 13 rack and pinion

**Figure 4 — Electric actuator, part-turn with reduction, single-acting with spring return**

### 6.2.2 Pneumatic

Typical configurations for pneumatic actuators are shown, for illustration purposes only, in Figures 5 to 9 and 11.

Pneumatic part-turn and multi-turn actuators shall be comprised of pneumatic cylinder(s) or another shape, appropriate gearing and travel stops.

Pneumatic actuators should be powered by compressed air, unless otherwise specified. Minimum compressed air cleanliness should be as given in ISO 8573-1:2010, class 5 for particle size and class 3 for dew point. Where other compressed gases or pressurized fluids are used, the internal actuator parts and lubricants shall be compatible.

### 6.2.3 Hydraulic

Typical configurations for hydraulic actuators are shown, for illustration purposes only, in Figures 5 to 8, 10 and 12 to 13.

Hydraulic part-turn and multi-turn actuators shall be comprised of hydraulic cylinder(s) or another shape, appropriate gearing and travel stops.

Hydraulic actuators shall be powered by pressurised hydraulic fluid. The hydraulic fluid shall be selected by agreement, ensuring compatibility with internal actuator parts and lubricants.

Minimum hydraulic fluid cleanliness shall be in accordance with ISO 4406:1999, class 19/17/14, unless otherwise agreed.

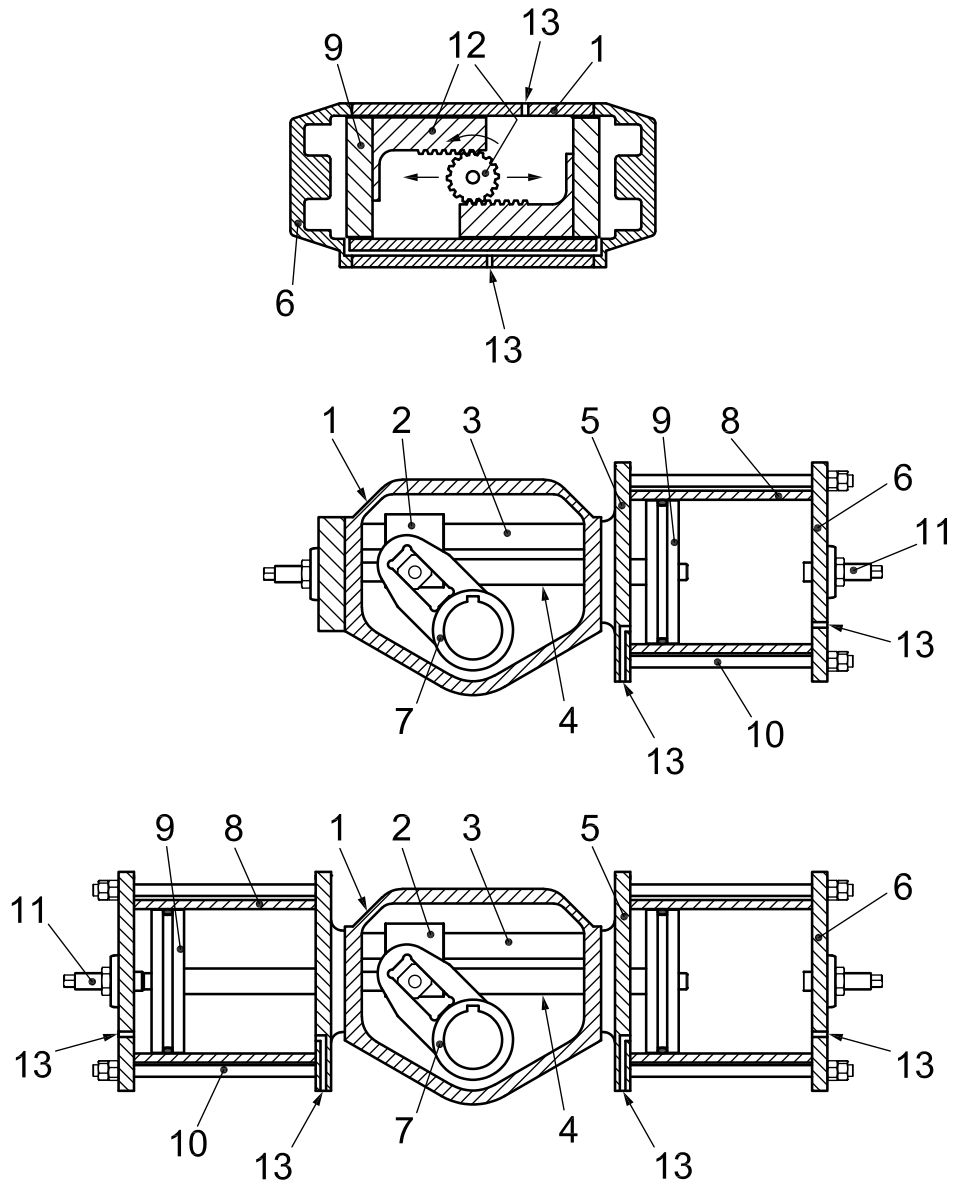

**Key**

- 1 housing
- 2 guide block
- 3 guide bar
- 4 piston rod
- 5 inner cap
- 6 outer cap
- 7 yoke
- 8 cylinder
- 9 piston
- 10 tie rod
- 11 travel stop
- 12 rack and pinion
- 13 pressure port

**Figure 5 — Pneumatic/hydraulic actuator, part-turn, double-acting**

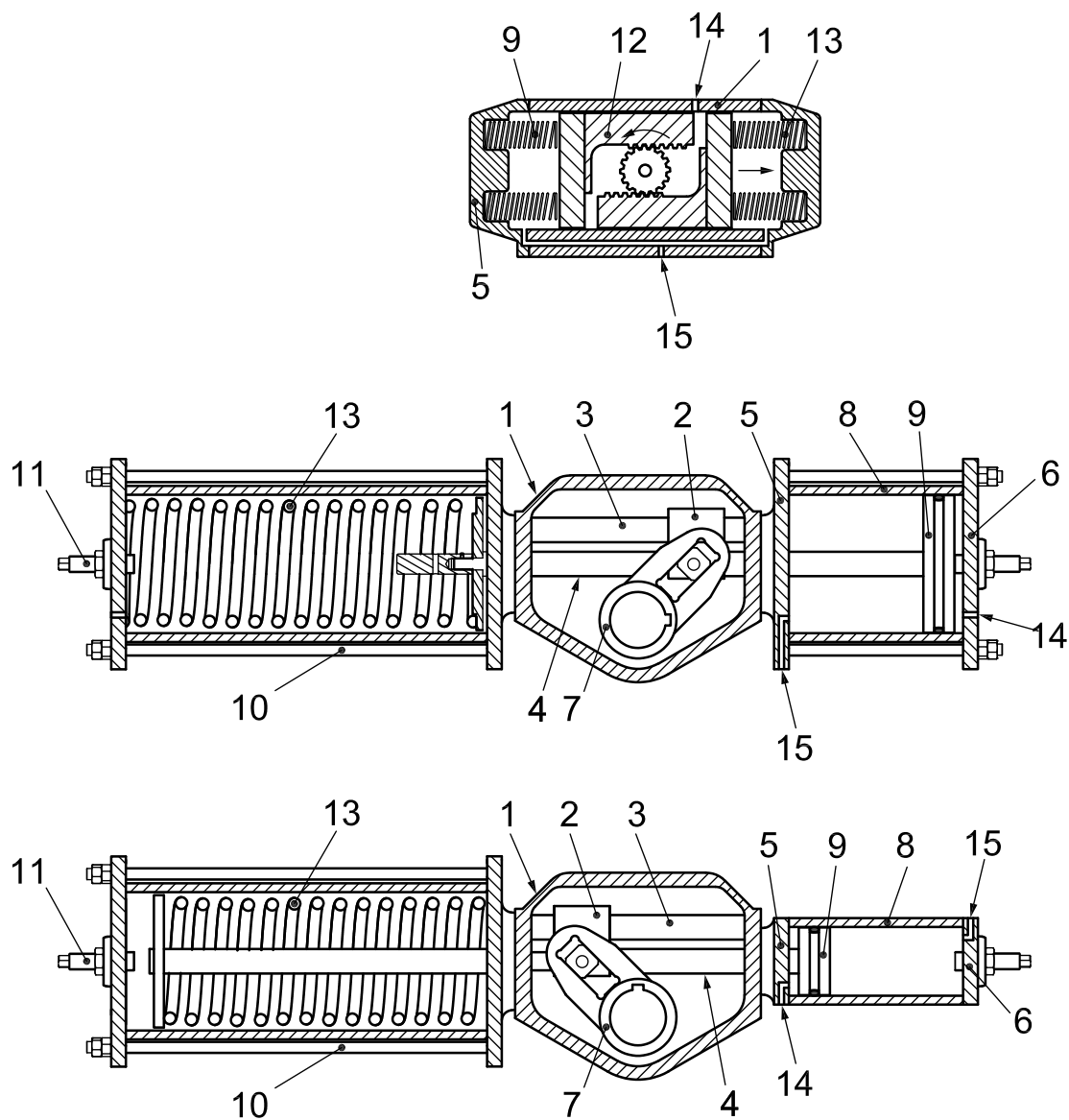

**Key**

- 1 housing
- 2 guide block
- 3 guide bar
- 4 piston rod
- 5 inner cap
- 6 outer cap
- 7 yoke
- 8 cylinder
- 9 piston
- 10 tie rod
- 11 travel stop
- 12 rack and pinion
- 13 spring
- 14 pressure port
- 15 pressure vent

**Figure 6 — Pneumatic/hydraulic actuator, part-turn, single-acting with spring return**

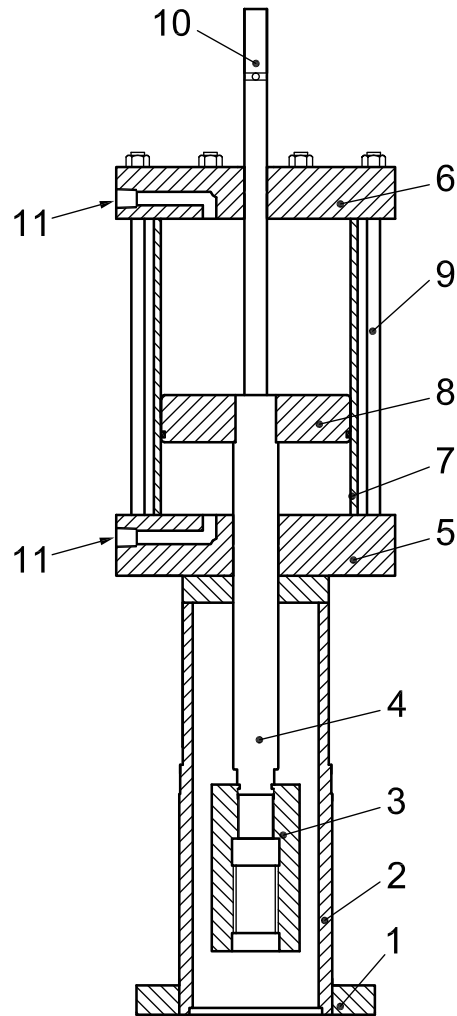

**Key**

- 1 mounting flange
- 2 pedestal
- 3 coupling
- 4 piston rod
- 5 lower cap
- 6 upper cap
- 7 cylinder
- 8 piston
- 9 tie rod
- 10 visual position indicator rod
- 11 pressure port

**Figure 7 — Pneumatic/hydraulic actuator, linear, double-acting**

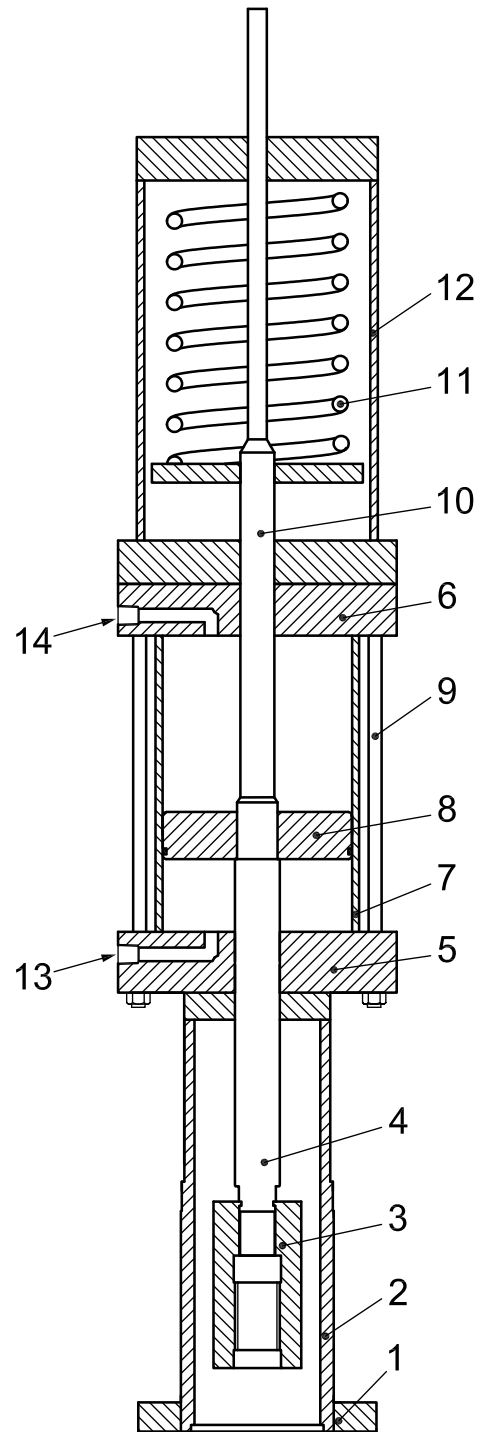

**Key**

- |   |                 |    |                               |
|---|-----------------|----|-------------------------------|
| 1 | mounting flange | 8  | piston                        |
| 2 | pedestal        | 9  | tie rod                       |
| 3 | coupling        | 10 | visual position indicator rod |
| 4 | piston rod      | 11 | spring                        |
| 5 | lower cap       | 12 | spring cartridge              |
| 6 | upper cap       | 13 | pressure port                 |
| 7 | cylinder        | 14 | pressure vent                 |

**Figure 8 — Pneumatic/hydraulic actuator, linear, single-acting with spring return**



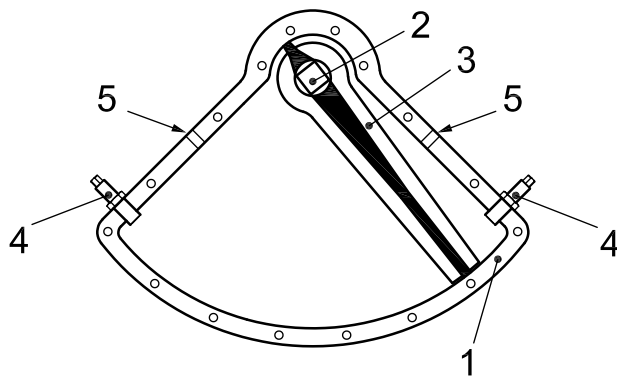

**Key**

- 1 housing
- 2 rotor/shaft
- 3 vane
- 4 travel stop
- 5 pressure port

**Figure 9 — Pneumatic actuator, vane, part-turn, double-acting**

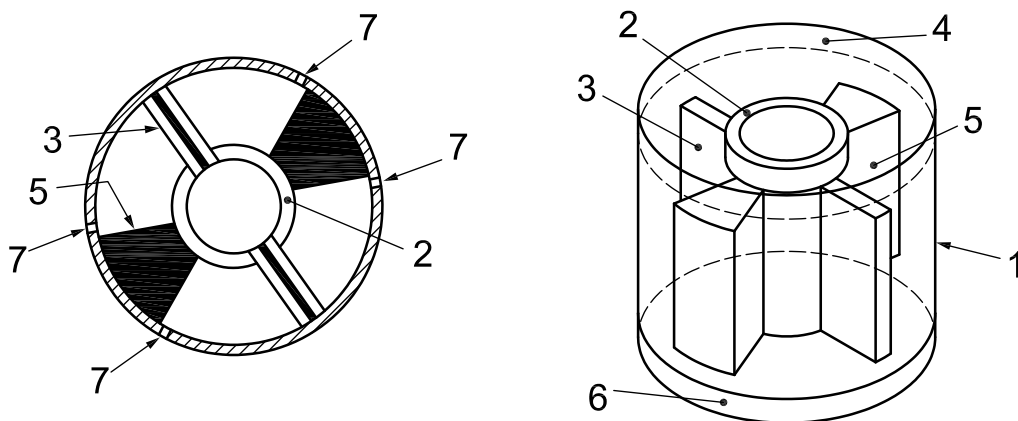

**Key**

- 1 housing
- 2 rotor/shaft
- 3 vane
- 4 cover
- 5 fixed shoe
- 6 base
- 7 pressure port

**Figure 10 — Hydraulic actuator, vane, part-turn, double-acting**

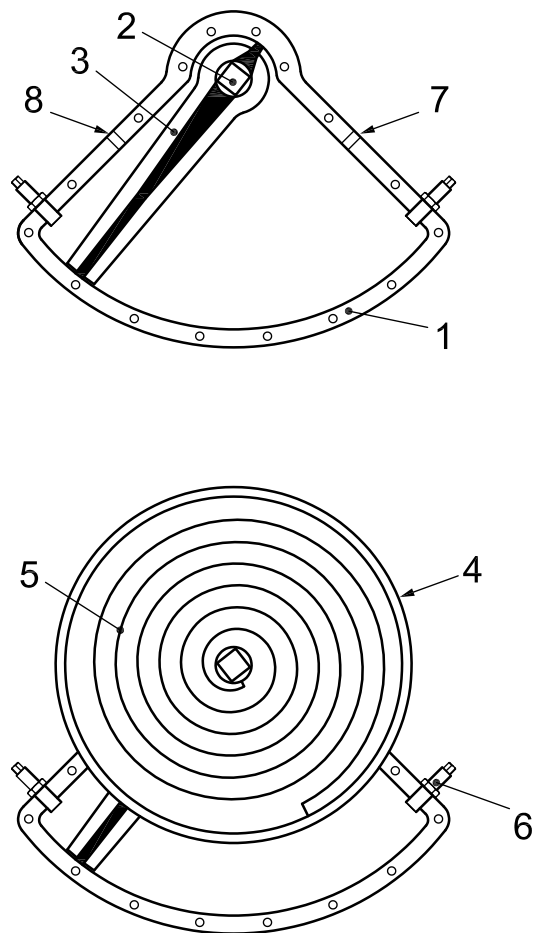

**Key**

- 1 housing
- 2 rotor/shaft
- 3 vane
- 4 spring housing
- 5 spring
- 6 travel stop
- 7 pressure port
- 8 pressure vent

**Figure 11 — Pneumatic actuator, vane, part-turn, single-acting, spring return**

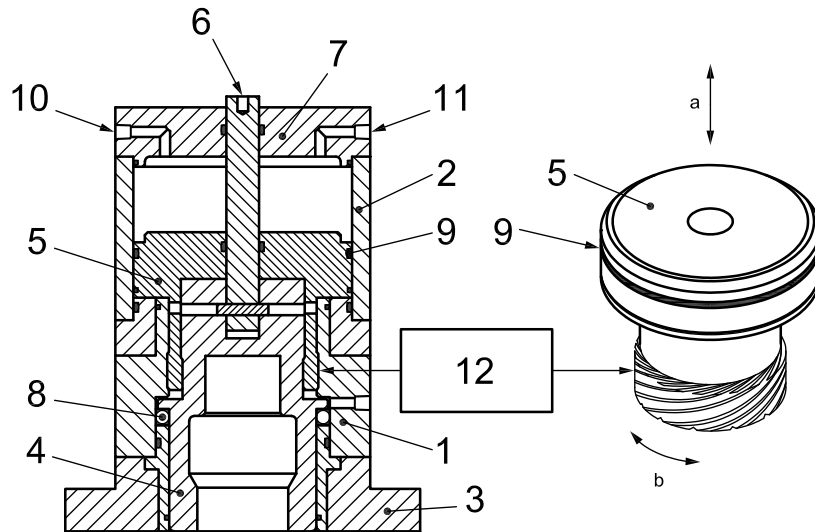

**Key**

- |                      |                   |
|----------------------|-------------------|
| 1 housing            | 7 cap             |
| 2 cylinder           | 8 thrust bushing  |
| 3 mounting flange    | 9 seal            |
| 4 coupling           | 10 pressure port  |
| 5 piston with helix  | 11 pressure vent  |
| 6 position indicator | 12 helical spline |
- a Axial thrust.  
 b Rotary motion.

**Figure 12 — Hydraulic actuator, helix, part-turn, double-acting**

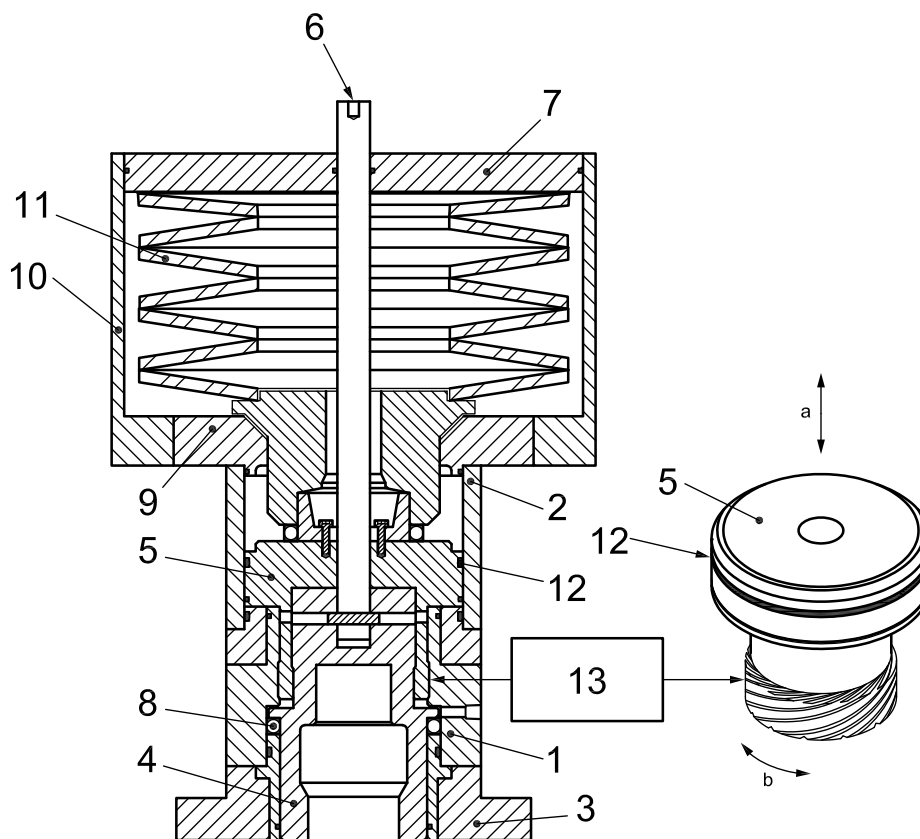

**Key**

- |                      |                     |
|----------------------|---------------------|
| 1 housing            | 8 thrust bushing    |
| 2 cylinder           | 9 cover             |
| 3 mounting flange    | 10 spring cartridge |
| 4 coupling           | 11 spring           |
| 5 piston with helix  | 12 seal             |
| 6 position indicator | 13 helical spline   |
| 7 cap                |                     |
| a Axial thrust.      |                     |
| b Rotary motion.     |                     |

**Figure 13 — Hydraulic actuator, helix, part-turn, single-acting, spring return**

### 6.3 Actuator configuration

#### 6.3.1 Double-acting

Typical configurations for double-acting actuators are shown, for illustration purposes only, in Figures 1, 2, 3, 5, 7, 9, 10 and 12.

NOTE Double-acting actuators can be of the electric, pneumatic, or hydraulic type and can have either part-turn, multi-turn or linear action. The design requires the application of supply energy to operate the actuator output in both directions.

**CAUTION — If supplying a double-acting actuator for fail-safe action, a suitable and appropriately sized stored energy device is required.**

### 6.3.2 Single-acting

Typical configurations for single-acting actuators are shown, for illustration purposes only, in Figures 4, 6, 8, 11 and 13.

NOTE Single-acting actuators can be of the electric, pneumatic, or hydraulic type and can have either part-turn or linear action to operate in one direction only, with the return stroke being powered by an alternative form of stored energy. Single-acting actuators are generally associated with fail-safe applications.

### 6.4 Action on loss of supply energy

Upon loss of supply energy, the valve shall be automatically driven to, or remain in, a predetermined position as defined by the purchaser. These positions are commonly as follows:

- fail-open;
- fail-closed;
- fail-last.

## 7 Design

### 7.1 General

The actuator portion of the interface between the actuator and the valve shall be in accordance with ISO 5210 or ISO 5211 unless otherwise agreed.

If alternative dimensions are used that are outside the scope of ISO 5210 or ISO 5211, they shall follow the design methodology and acceptance criteria of these International Standards unless otherwise agreed.

Actuators that are subjected to frequent cycling and/or rapid operation can require additional design considerations, including fatigue analysis and impact as appropriate.

Design verification and/or validation, including a design review, shall be performed.

For pneumatic and hydraulic actuators,

- a) the design pressure being used for the design of the pressure-containing parts shall be specified by the actuator manufacturer, and
- b) the maximum rated pressure shall be defined by the actuator manufacturer, and shall be less than or equal to the design pressure and greater than or equal to the maximum operating pressure.

These actuator pressure relationships are illustrated in Figure 14. The relationships between energy (e.g. pressure and voltage), torque/thrust, component part design and sizing are shown in Figure 15, along with references to the corresponding subclause(s).

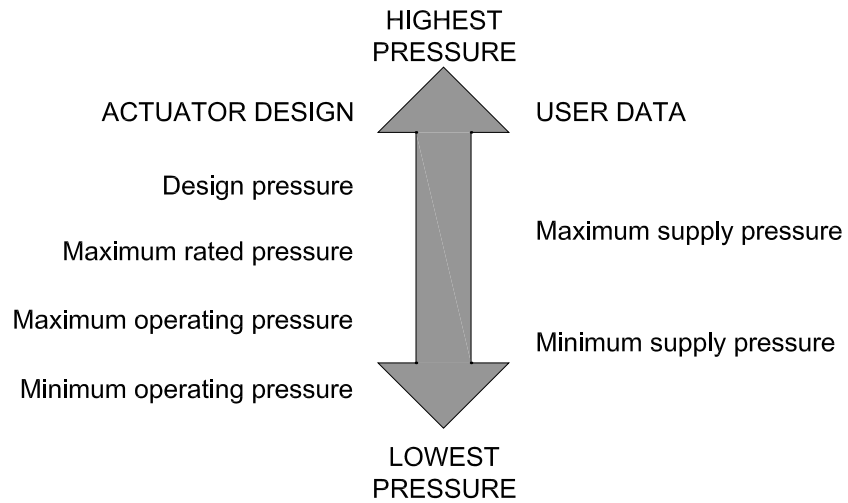

**Figure 14 — Relationship between design, supply and rated pressures**

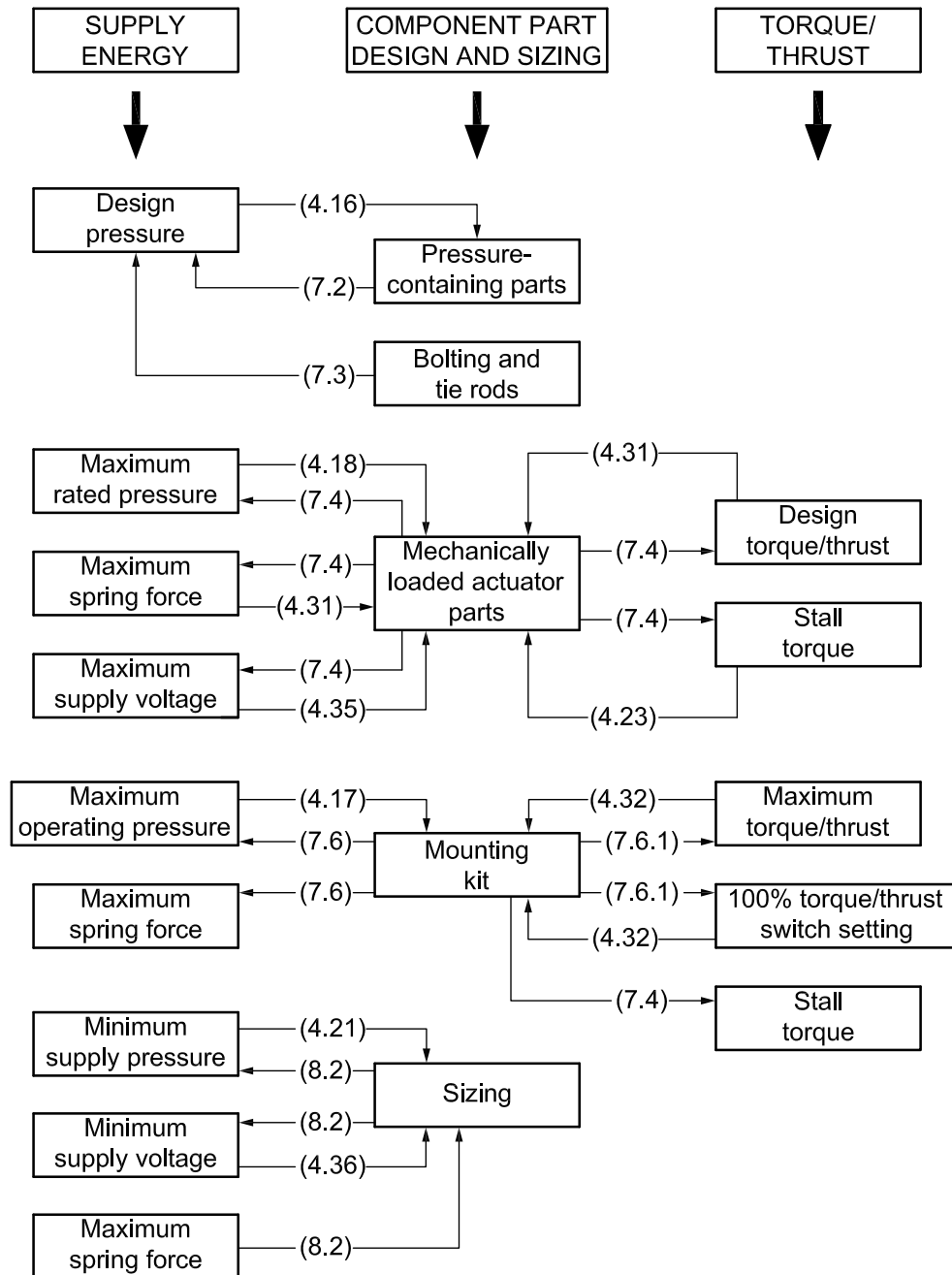

NOTE The numbers in brackets refer to the corresponding subclause.

**Figure 15 — Relationship between energy, torque/thrust and actuator design and sizing**

## 7.2 Pressure-containing parts

Pressure-containing parts, such as the cylinder heads and cylinder, shall be designed in accordance with one of the following:

- ASME BPVC Section VIII, Division 1 or Division 2;
- EN 12516-1, EN 12516-2 or EN 13445-3;
- other internationally recognized design codes or standards by agreement.

The use of proprietary design methodology, calculations, acceptance criteria and satisfactory documented previous experience including validation testing shall be by agreement.

NOTE Associated fittings and actuator control equipment are not within the scope of this International Standard.

### 7.3 Bolting and tie rod design

Bolting and tie rod design for pressure-containing parts shall be in accordance with the selected design code (see 7.2), unless otherwise agreed.

### 7.4 Mechanically loaded parts

Mechanically loaded parts shall be designed to accommodate the maximum anticipated in-service load, including design torque/thrust, and shall take into account the following:

- torque/thrust generated at maximum rated pressure, for pneumatic/hydraulic actuators;
- torque/thrust generated by maximum compressed spring force, for spring return actuators;
- torque/thrust at maximum supply voltage;
- torque/thrust at stall condition, for electric actuators.

Mechanically loaded parts shall be designed in accordance with a documented methodology, including acceptance criteria. Acceptance criteria shall include analysis of stress, strain (and fatigue where applicable) encountered during operation at maximum torque/thrust output. Alternatively, acceptance criteria may be satisfactory documented previous experience including validation testing.

### 7.5 Springs and modules

The spring(s) on spring return actuators shall be designed in accordance with internationally recognized design codes or standards. If no equations exist for the spring type, a proprietary equation may be used provided it has been validated by cycle testing.

NOTE An example of an internationally recognized design code or standard is EN 13906.

A qualification test shall be performed on all spring(s) by full-load cycling a minimum of five times followed by load testing to validate the actuator spring design data. Additionally, a sample of each production batch of springs shall be subjected to the same test to verify the performance.

The manufacturer shall provide procedures for the safe removal of the spring/spring module.

### 7.6 Mounting kit

**7.6.1** Design basis shall be either stress-based or based on satisfactory documented previous experience including validation testing.

The mounting kit shall be designed to transfer all of the loads from the actuator to the valve and to react to them, including loads of 1,1 or more times the maximum torque/thrust output, and it shall take into account the following:

- torque/thrust generated at maximum operating pressure or as limited by relief valve or other pressure-limiting device, for pneumatic/hydraulic actuators;
- torque/thrust generated by maximum compressed spring force, for spring return actuators;
- torque/thrust at stall condition or 100 % torque/thrust switch setting, for electric actuators.

The maximum torque/thrust output shall be less than or equal to the design torque/thrust.



Tensile stresses in mounting kit components shall not exceed 67 % of SMYS when delivering 1,1 or more times the maximum torque/thrust output. Shear, torsion and bearing stresses shall not exceed the limits specified in ASME BPVC Section VIII:2004, Division 2, Part AD-132, except that design stress intensity values,  $S_m$ , shall be 67 % of SMYS.

A strength efficiency factor of 0,75 shall be used for fillet welds, unless otherwise agreed. For additional welding requirements, see 11.1.

**7.6.2** For all mounting kits, attention shall be paid to deflection and strain. Adherence to these allowable stress limits alone might not result in a functionally acceptable design for the actuated valve assembly.

NOTE Ensuring that the valve (e.g. bolting) is capable of transferring all of the loads from the actuator to the valve and of reacting to them, including loads of 1,1 or more times the maximum torque/thrust output, is the responsibility of the valve manufacturer.

Bolting in mounting kits shall not be subjected to shear forces, unless otherwise agreed.

The mounting kit design and manufacturing tolerance shall ensure the following:

- parallelism of the intermediate support mounting faces;
- concentricity of the PCD of the bolting of the intermediate support;
- alignment of the PCD, valve stem, coupling and the actuator drive.

**7.6.3** The mounting kit design shall also consider the following:

- installed orientation of the valve and actuator;

NOTE Valves installed with horizontal stems can require additional support, e.g. spigots, to ensure accurate alignment of valve and actuator during removal and refitting in field service.

- external loading from environmental effects (e.g. wind, snow, seismic activity);
- blast loading, if specified;
- frequency of cycling and speed of operation.

## 7.7 Stem extensions

Stem extensions shall be designed in accordance with ISO 14313:2007, 7.20.2.

## 7.8 Lifting

For actuators heavier than 25 kg, lifting points shall be identified, for the purpose of lifting the actuator alone during installation or maintenance, unless otherwise agreed.

The supplier of the actuated valve assembly shall identify the lifting points for the complete actuated valve assembly.

NOTE Regulatory requirements can specify special design, manufacturing, testing and certification of lifting points.

## 7.9 Handwheels and levers for manual override

If a handwheel or lever is provided, the maximum force required at the handwheel or lever to apply the breakaway torque or thrust shall not exceed 360 N (80 lbf).

Handwheel diameter(s) shall not exceed 800 mm, unless otherwise agreed. Spokes shall not extend beyond the perimeter of the handwheel.

The direction of closing for handwheel and lever shall be clockwise, unless otherwise agreed.

## 7.10 Locking devices

Actuators shall be supplied with locking devices if specified by the purchaser.

## 7.11 Position indicators

Actuators shall be furnished with a visible indicator to show the open and the closed positions of the valve obturator.

## 7.12 Travel stops

Part-turn actuators shall include adjustable travel stops and they shall locate the position of the obturator in the open and closed positions, unless otherwise agreed.

Linear actuators shall have adjustable travel stop(s) if required by the application.

## 7.13 Orientation

Actuators with multiple-orientation capability may be supplied. If specified by the purchaser, incorrect angular orientation or improper assembly of the actuator to the valve shall be prevented by suitable means, such as a dowel pin or fitted bolt that ensures the correct location of the actuator.

The purchaser shall provide details regarding installed orientation of the actuated valve assembly and the direction from which local access is required, including pipeline direction and stem direction (e.g. horizontal, vertical, inclined, etc.) and actuator orientation (e.g. in-line or transverse to pipeline).

NOTE The most common orientation is pipeline horizontal, stem vertical, actuator in line with pipeline.

## 7.14 Sealing

Actuators shall be type-tested to IP-65 in accordance with IEC 60529 as a minimum.

## 7.15 Over-pressure protection

Actuators and/or mounting kits shall be provided with a means of preventing pressure build-up in the mechanism resulting from leakage from the valve stem or bonnet seal leakage.

## 7.16 Design documents

The design shall be documented in a retrievable and reproducible form.

Design documentation shall be reviewed and verified by competent personnel other than the person who performed the original design.

# 8 Sizing

## 8.1 Information required for actuator sizing

### 8.1.1 General

The purchaser shall ensure that when purchasing an actuator for a valve, the MAST and maximum torque/thrust are compared to ensure compatibility of design.

NOTE There are potentially multiple entities involved in the process of purchasing an actuator or an actuated valve assembly. It is imperative that information as described in 8.1.2 to 8.2 is exchanged, to ensure that the necessary entities provide and receive the required information for the supply of an actuator, mounting kit or actuated valve assembly.

All required torque/thrust values in 8.1.2 are net values and shall not include an external safety factor.

Example data sheets that can be used for supplying the required data are given in Annex C.

### **8.1.2 Valve torque and/or thrust data**

The following data shall be generated by the valve manufacturer, for both opening and closing directions:

- a) breakaway torque/thrust;
- b) breakaway angle or percent of stroke;
- c) run torque/thrust;
- d) reseal torque/thrust;
- e) MAST.

**NOTE** The breakaway angle or percent of stroke is the point at which the seat breaks/makes sealing contact with the obturator. The breakaway angle or percent of stroke can be significant to actuator sizing when in excess of 5° or 5 % respectively.

For actuators powered directly from a gas pipeline, the torque/thrust data associated with minimum and maximum pipeline operating pressures at operating temperature shall be defined.

Other specific torque or thrust conditions of the valve shall be made known to the actuator manufacturer. For linear valves operated by a multi-turn actuator, the input torque and thrust shall both be specified.

For valves with a preferred sealing direction, the valve manufacturer shall state whether the torque/thrust data are based on the preferred or the non-preferred sealing direction.

### **8.1.3 Safety factor and operating time**

The following data shall be provided by the purchaser, for both opening and closing directions:

- a) minimum and maximum operating time;
- b) actuator sizing safety factor at 8.1.2 a), c) and d).

### **8.1.4 Valve dimensions**

The valve manufacturer/supplier shall provide all relevant valve dimensions, including but not limited to the following:

- a) stem dimensions;
- b) stem thread form, pitch, lead, whether right-hand or left-hand and number of starts;
- c) dimensions of stem key;
- d) mounting pattern (top works) dimensions.

### **8.1.5 Electric actuator data**

For electric actuators, the following data shall be provided by the purchaser:

- a) voltage, phase, frequency;
- b) voltage variation and frequency variation;

- c) number of consecutive valve strokes;
- d) number of starts per hour;
- e) minimum and maximum operating and ambient temperatures;
- f) actuator configuration (single- or double-acting);
- g) action on loss of supply energy (close, open or last);
- h) number of strokes from stored-power source.

#### **8.1.6 Pneumatic/hydraulic actuator data**

For pneumatic and hydraulic actuators, the following data shall be provided by the purchaser:

- a) fluid type, cleanliness and, where applicable, gas composition;
- b) minimum and maximum supply pressure;
- c) minimum and maximum operating and ambient temperatures;
- d) actuator configuration (single- or double-acting);
- e) action on loss of supply energy (close, open or last);
- f) number of strokes from stored-pressure source, if applicable.

Stroke damping may be required to control operating speed.

Maximum supply pressure, by agreement, may be regulated by the manufacturer or supplier for the purpose of meeting sizing requirements (in doing so, it becomes the maximum operating pressure, which shall be less than or equal to the maximum rated pressure).

## **8.2 Sizing method**

The valve torque/thrust values and other related data shall be determined as described in 8.1.

The actuator shall be selected based on minimum supply voltage or minimum supply pressure, maximum compressed spring force and other related data as described in 8.1.

Actuator maximum output torque/thrust based on the maximum supply voltage or operating pressure shall not exceed the valve MAST at any point of travel. For pneumatic/hydraulic actuators, when the maximum supply pressure is reduced by means of a regulator and relief valve system, then the pressure used to establish the maximum output torque/thrust shall be based on the relief valve set pressure. For electric actuators, when torque/thrust-limiting devices are active, the maximum torque/thrust shall be based on the rated torque/thrust setting unless otherwise agreed.

## **9 Instrumentation/regulation**

### **9.1 Torque limiting settings — Electric actuators**

The maximum output torque shall not exceed the valve MAST.

Torque-limiting devices shall not be bypassed unless otherwise agreed.

## 9.2 Torque/thrust limiting controls — Pneumatic/hydraulic actuators

If the output of a pneumatic or hydraulic actuator has the potential to exceed the valve MAST, a regulator shall be used along with a safety relief valve. The torque/thrust output at the relief valve set pressure shall be less than the valve MAST.

NOTE Typically, the minimum relief valve set pressure is either 110 % of regulator set pressure or +50 kPa [+0,5 bar; +7.3 psi].

Alternative means of limiting supply pressure may be offered by agreement.

## 10 Materials

### 10.1 Material specification

Specifications for metallic pressure-containing parts shall be issued by the manufacturer and shall address, as a minimum, the following:

- a) material type and grade (e.g. carbon steel, austenitic stainless steel, ferritic ductile iron, non-ferrous alloys, etc.);
- b) product form;
- c) chemical composition;
- d) condition/heat treatment;
- e) mechanical properties;
- f) Charpy impacts, if applicable;
- g) type of inspection document in accordance with ISO 10474 or EN 10204.

### 10.2 Service compatibility

All parts, metallic and non-metallic, in contact with the operating fluids and lubricants shall be suitable for the commissioning fluids and service specified by the purchaser. Metallic materials shall be selected in such a manner as to avoid corrosion and galling which can impair function and/or pressure-containing capability.

### 10.3 Composition limits

#### 10.3.1 Carbon steel

The chemical composition of carbon steel pressure-containing parts subject to welding, including weld repairs and overlays, shall meet the following requirements unless otherwise agreed.

— Carbon content shall not exceed 0,25 % mass fraction.

— Carbon equivalent (CE) shall not exceed 0,42.

CE shall be calculated in accordance with Equation (1):<sup>6)</sup>

$$CE = \%C + \%Mn/6 \quad (1)$$

6) The symbols used in this equation are not in accordance with the ISO directives for elements used in mathematical equations. However, due to its wide-spread use, a derogation has been granted to retain this equation in its original form.

### 10.3.2 Austenitic stainless steel

The carbon content of austenitic stainless steel pressure-containing parts subject to welding, including weld repairs, shall not exceed 0,03 % mass fraction, except that for stabilized material a carbon content of up to 0,08 % mass fraction is permissible.

The chemical composition of other materials of pressure-containing parts subject to welding, including weld repairs, shall be established by agreement.

### 10.3.3 Ductile iron

The overall composition, general requirements, and micro-structural carbide and graphite content of ductile iron pressure-containing parts shall be governed by a nationally or internationally recognized standard that is applicable to the temperature range of the actuator environment.

The chemical composition of ductile iron shall meet the following requirements, unless otherwise agreed:

- Ferritic ductile iron shall have a minimum carbon content of 3,0 %.
- Silicon content shall be at least 2,0 %.
- Maximum silicon content shall be in accordance with Equation (2) up to 2,75 % mass fraction:

$$\%S_{\max} = 2,5 + 8 \times (0,08 - \%P) \quad (2)$$

Maximum silicon content may be raised to 3,0 % if both phosphorous (P) content is limited to 0,02 % and manganese (MN) content is within the range 0,15 % to 0,25 %.

### 10.3.4 Other materials

The chemical composition of other materials used for pressure-containing parts shall be established by agreement, and shall be subject to the requirements of 10.1.

## 10.4 Toughness test requirements for pressure-containing parts

All carbon steels, alloy steels and non-austenitic stainless steel for pressure-containing parts shall meet the toughness test requirements of the selected design code or standard in 7.2, unless otherwise agreed. Toughness requirements for other materials shall be determined by agreement.

All carbon steels, alloy steels and non-austenitic stainless steel for pressure-containing parts with a specified design temperature below  $-29\text{ }^{\circ}\text{C}$  ( $-20\text{ }^{\circ}\text{F}$ ) shall be impact tested using the Charpy V-notch technique in accordance with ISO 148-1 or ASTM A370.

NOTE Design standards or local requirements can require impact testing for minimum design temperatures above  $-29\text{ }^{\circ}\text{C}$  ( $-20\text{ }^{\circ}\text{F}$ ).

A minimum of one impact test, comprised of a set of three specimens, shall be performed on a representative test bar of each heat of the material in the final heat-treated condition.

Test specimens shall be cut from a separate or attached block taken from the same heat, reduced by forging where applicable, and heat-treated using the same heat treatment, including stress relieving, as for the product material. It is not necessary that pressure-containing parts stress relieved at or below a previous stress relieving or tempering temperature be retested.

The impact test shall be performed at the lowest temperature defined in the applicable material specifications or the minimum design temperature.

Except for material for bolting, impact test results for full-size specimens shall meet the more restrictive requirements of the material specification or the design standard, unless otherwise agreed.

Impact test results for bolting material shall meet the requirements of ASTM A320/A320M, unless otherwise agreed.

### **10.5 Bolting for pressure-containing, mechanically loaded parts and mounting kits**

Bolting material shall be selected to meet the requirements of the specified valve and actuator service.

Carbon, low-alloy and austenitic stainless steel bolting material with a hardness exceeding HRC 34 (HBW 321) shall not be used for applications where hydrogen embrittlement can occur, unless otherwise agreed.

NOTE 1 Hydrogen embrittlement can occur in buried pipelines with cathodic protection.

NOTE 2 Some materials can be susceptible to environmentally assisted cracking.

### **10.6 Mechanically loaded parts**

Specifications for metallic mechanically loaded parts and components of mounting kits shall be issued by the manufacturer and shall include, as a minimum, the following:

- a) mechanical properties;
- b) Charpy impacts, if applicable;
- c) type of inspection document in accordance with EN 10204.

### **10.7 Sour service**

Materials for pressure-containing parts and bolting shall meet the requirements of ISO 15156 (all parts) if specified by the purchaser.

## **11 Welding**

### **11.1 Welding of pressure-containing parts**

Welding, including repair welding, of pressure-containing parts and attachment welding to pressure-containing parts shall be performed in accordance with procedures qualified to ISO 15607, ISO 15609 (all parts), ISO 15614-1 or ASME BPVC Section IX and 11.3 and 11.4 of this International Standard. Welders and welding operators shall be qualified in accordance with ISO 9606-1, ASME BPVC Section IX or EN 287-1.

NOTE The purchaser, material specifications and local requirements can specify additional requirements.

The results of all qualification tests shall be documented in a PQR.

PWHT shall be performed in accordance with the relevant WPS.

### **11.2 Structural welding**

Welding, including repair welding, of structural welds, including mounting kit, shall be performed in accordance with procedures qualified to ANSI/AWS D1.1/D1.1M or an equivalent standard. Welders and welding operators shall be qualified in accordance with ANSI/AWS D1.1/D1.1M or an equivalent standard.

Alternatively, structural welding, WPS, and PQR in accordance with procedures qualified to ISO 15607, ISO 15609 (all parts), ISO 15614-1 or ASME BPVC Section IX and welders and welding operators qualified in accordance with ISO 9606-1, ASME BPVC Section IX or EN 287-1 are acceptable.

### 11.3 Impact testing

Qualifications of procedures for welding of pressure-containing parts, including repair welding, shall be performed at the lowest temperature defined in the applicable material specifications or at the minimum design temperature.

Impact testing for qualification of the WPS is not required for non-impact-tested base materials, or for materials in service above  $-29\text{ }^{\circ}\text{C}$  ( $-20\text{ }^{\circ}\text{F}$ ), unless otherwise agreed.

NOTE Design standards and/or local requirements can require impact testing at minimum design temperatures above  $-29\text{ }^{\circ}\text{C}$  ( $-20\text{ }^{\circ}\text{F}$ ).

A set of three weld metal impact specimens shall be taken from the weld metal (WM) at the location shown in Figure 16. The specimens shall be oriented with the notch perpendicular to the surface of the material.

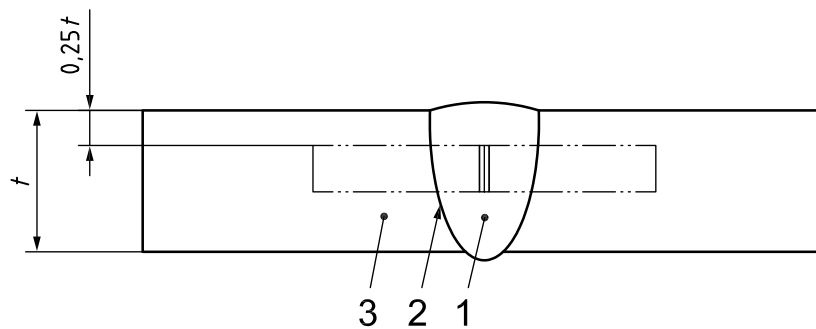

**Key**

- 1 weld metal
- 2 heat-affected zone
- 3 base metal

**Figure 16 — Charpy V-notch weld metal (WM) specimen location**

A set of three impact specimens shall be taken from the heat-affected zone (HAZ) at the location shown in Figure 17. The notch shall be positioned perpendicular to the material surface at a location whereby a maximum amount of HAZ material is located in the resulting fracture.

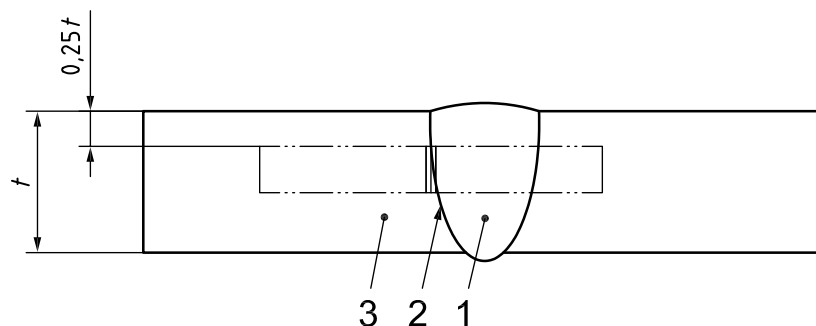

**Key**

- 1 weld metal
- 2 heat-affected zone
- 3 base metal

**Figure 17 — Charpy V-notch heat-affected zone (HAZ) specimen location**



HAZ tests shall be conducted for each of the materials being joined when the base materials being joined are of a different P-number and/or group-number in accordance with ISO 9606-1, ISO 15607, ISO 15609 (all parts), ISO 15614-1 or ASME BPVC Section IX when one or both of the base materials being joined are not listed in the P-number grouping.

Impact testing shall be performed in accordance with ISO 148-1 or ASTM A370 using the Charpy V-notch technique. Specimens shall be etched to determine the location of the weld and HAZ.

Impact test results for full-size specimens shall meet the requirements of the material specification or the design standard, unless otherwise agreed.

#### **11.4 Hardness testing**

Hardness testing shall be carried out as part of the welding procedure qualification on pressure-containing parts in process-wetted conditions if required to meet the requirements of ISO 15156 (all parts). Hardness surveys shall be performed on BM, WM and the HAZ in accordance with the requirements of ISO 15156 (all parts). The hardness method used shall be Vickers HV<sub>5</sub> or HV<sub>10</sub>.

NOTE For existing qualification, other hardness measurement methods (such as HRC or HRB) are acceptable.

#### **11.5 Repair**

Minor defects may be removed by grinding, provided there is a smooth transition between the ground area and the original contour and the minimum wall/weld thickness requirements are not affected.

Repair of defects shall be performed in accordance with a documented procedure specifying requirements for defect removal, welding, heat treatment, NDE and reporting as applicable.

For welds on pressure-containing parts, repairs of fabrication welds shall be limited to 30 % of the weld length for partial-penetration repairs or 20 % of the weld length for full-penetration repairs, except that the minimum length of any weld repair shall be 50 mm. For defects with sizes greater than these limits, the entire weld shall be removed and re-welded.

The heat treatment (if applicable) of weld repairs shall be in accordance with the applicable material standard.

Weld repair of forgings and plates to correct manufacturing defects shall be carried out by agreement.

Weld repair of castings shall be carried out in accordance with the applicable material standard.

### **12 Quality control**

#### **12.1 NDE requirements**

##### **12.1.1 General**

NDE shall be conducted prior to coating or surface treatment. Final NDE activities shall be conducted after heat treatment unless otherwise agreed.

##### **12.1.2 Pressure-containing parts**

NDE of parts and welds shall be in accordance with the selected design code in 7.2. All parts shall be subjected to a visual inspection in accordance with the material specification. If specified by the purchaser, welds on pressure-containing parts shall be subjected to additional NDE. The NDE method and acceptance criteria shall be selected by agreement.

### **12.1.3 Mechanically loaded parts, including mounting kit**

Visual inspection of welds shall be in accordance with ANSI/AWS D1.1/D.1.1M or an equivalent standard. Parts shall be subjected to a visual inspection in accordance with the manufacturer's quality procedures. If specified by the purchaser, welds on parts shall be subjected to additional NDE. The NDE method and acceptance criteria shall be selected by agreement.

## **12.2 Measuring and test equipment**

### **12.2.1 General**

Measuring and test equipment shall be identified, controlled and calibrated at intervals specified in the manufacturer's internal quality procedures.

### **12.2.2 Pressure-measuring devices**

Pressure-measuring devices shall be accurate to within  $\pm 2,0$  % of the full-scale reading.

Pressure measurements shall be made at between 25 % and 75 % of the full pressure range of the measuring device.

Pressure-measuring devices shall be calibrated with a master pressure-measuring device or a dead-weight tester at 25 %, 50 % and 75 % of the full pressure scale.

### **12.2.3 Torque-/thrust-measuring devices**

Torque-/thrust-measuring devices shall be accurate to within  $\pm 2,0$  % of the full-scale reading.

Torque/thrust measurements shall be made at between 25 % and 75 % of the full range of the measuring device.

Torque-/thrust-measuring devices shall be calibrated with a master device at 25 %, 50 % and 75 % of the full scale.

## **12.3 Qualification of inspection and test personnel**

### **12.3.1 NDE personnel**

NDE personnel shall be qualified in accordance with the requirements specified in ISO 9712, EN 473 or ASNT SNT-TC-1A Level II.

Personnel performing visual examinations shall have passed an eye examination in accordance with ISO 9712, EN 473 or ASNT SNT-TC-1A within the previous 12 months.

### **12.3.2 Test personnel**

Personnel performing functional testing shall be trained in accordance with the manufacturer's internal procedures.

### **12.3.3 Welding inspectors**

Personnel performing visual inspection of welding operations and completed welds shall be qualified and certified to the requirements of AWS QC1 or equivalent, or of a manufacturer's documented training programme.

## 12.4 NDE of repairs

### 12.4.1 Pressure-containing parts

After defect removal, the excavated area shall be examined by magnetic particle (MT) or liquid penetrant (PT) methods in accordance with the selected design code. Repair welds shall be examined using the same NDE method that was used to detect the defect with a minimum of MT or PT. Acceptance criteria shall be as specified in the selected design code for the appropriate product form. The final NDE activities shall be conducted after post-weld heat treatment unless otherwise agreed.

### 12.4.2 Mechanically loaded parts

Repair welds shall be examined using the same NDE method that was used to detect the defect.

## 12.5 Visual inspection of castings

As a minimum, all castings shall be visually inspected in accordance with MSS SP-55.

## 13 Testing

### 13.1 General

Each actuator shall be tested prior to shipment. The purchaser shall specify if any of the supplementary tests in Annex A shall be performed.

Testing shall be performed in the sequence detailed in 13.2 to 13.6.

Test fluid should be representative of the application operating fluid, wherever practical.

Pneumatic equipment may be tested with air provided it is located in a safe, restricted area.

Pressure testing shall be performed in accordance with documented procedures.

Methods for monitoring pressures and/or leakage shall be in accordance with documented procedures. For pneumatic shell testing, the test pressure shall be applied, and the method for detecting leakage (e.g. bubble/soap solution, acoustic monitoring, manometer) shall be fully applied and in place prior to starting the minimum duration.

Test pressure shall be stabilized and isolated prior to the start of pressure testing and shall be held for the minimum test durations listed in Tables 1 and 2.

### 13.2 Shell test

The test pressure shall be in accordance with the design code in 7.2, or 1,5 or more times the design pressure, by agreement. The duration shall be in accordance with the design code in 7.2 or with Table 1 below, whichever is longer.

**Table 1 — Minimum duration of shell tests**

| Test      | Test duration<br>s |
|-----------|--------------------|
| Pneumatic | 60                 |
| Hydraulic | 120                |

Test pressure shall be held for a sufficient duration as to permit full inspection of potential leak paths. For large actuators, it can be necessary to extend this duration to fully validate the test.

There shall be no visible leakage for the duration of the test.

### 13.3 Piston seal test

Pneumatic piston seal tests shall be conducted with pressure applied to one side of the piston and the other side open to atmospheric pressure and using a means of visual inspection.

Hydraulic piston seal tests shall apply pressure to one side of the piston and then provide for isolation from the pressure source.

Double-acting actuators shall be tested from both directions.

NOTE Specific actuator types with permissible leakage, such as vane actuators, can require alternative test procedures.

The test pressure for all piston seal tests shall be 1,1 or more times the maximum rated pressure. The test duration shall be in accordance with Table 2.

Actuators should be operated prior to performing the piston seal test.

**Table 2 — Minimum duration of piston seal tests**

| Test      | Test duration<br>s |
|-----------|--------------------|
| Pneumatic | 30                 |
| Hydraulic | 45                 |

There shall be no visible leakage for the duration of the test.

### 13.4 Torque/thrust test — Pneumatic/hydraulic actuators

The manufacturer shall have proven, documented procedures and associated acceptance criteria in place that demonstrate an ability to verify and validate the performance characteristics of the actuator.

The purchaser may specify additional torque testing on either prototype or production actuators.

### 13.5 Testing of electric actuators

#### 13.5.1 General

The production tests given 13.5.2 to 13.5.4 provide the minimum requirement in order to comply with the requirements of this International Standard. Test results shall be recorded and made available to the purchaser.

All electric actuators (excluding valve gearbox) shall be tested as described in 13.5.2 to 13.5.4 and 13.6.

Gearbox performance data shall be validated by type test and calculation or by agreement. Where scotch-yoke types are employed, the manufacturer/supplier shall make the torque-stroke profile available.

For combinations of electric multi-turn actuator and gearboxes supplied by the actuator manufacturer/supplier, combination production tests are not compulsory, and otherwise shall be carried out by agreement. Combination output torque shall be made available but may be derived via calculation based on gearbox performance data and electric actuator performance characteristics validated by means of production testing.

The tests in 13.5.2 to 13.5.4 and 13.6 shall be carried out at specified voltage/frequency unless otherwise agreed. Tests shall be conducted in both directions using a suitable calibrated test rig.

### **13.5.2 Output torque test**

#### **13.5.2.1 Stall torque**

With the motor energized, torque-limiting devices de-activated and the output drive locked, the maximum torque shall be measured and recorded. In the event of test limitations, and by agreement, the stall torque shall be reported based on calculation.

#### **13.5.2.2 Rated torque**

With calibrated torque-limiting device(s) set at 100 %, the torque shall be measured and recorded to validate the manufacturer's rated torque/thrust output.

In addition, torque-limiting device(s) may be set to an operational value below 100 % by agreement. A functional test of torque-limiting devices shall be carried out in order to demonstrate de-energization of the motor. Setting the torque-limiting device(s) to an operational value below 100 % does not remove the requirement to test the rated torque described above.

### **13.5.3 Output position test**

Functional testing of travel-limiting devices shall be carried out in order to demonstrate de-energization of the motor at preset positions in the stroke (open/close). For multi-turn actuators/combinations, travel-limiting devices shall be set to the manufacturer's default output turns range or to a range specified by the purchaser. For part-turn actuators/combinations, travel-limiting devices shall be set to the mechanical stops as applicable in accordance with the actuator manufacturer's/supplier's instructions.

### **13.5.4 Operating time test**

#### **13.5.4.1 Part-turn actuator**

The operating time of the actuator shall be validated. For part-turn actuators/combinations, the operating time is defined as the duration, expressed in seconds, of the complete angular stroke at the valve stem, and shall be recorded.

#### **13.5.4.2 Multi-turn actuator**

The operating time of the actuator shall be validated. For multi-turn actuators/combinations, where the output turns are advised, the operating time is defined as the duration, expressed in seconds, of the complete stroke at the valve stem, and shall be recorded. Where output turns are unknown, the revolutions per minute of the actuator shall be recorded.

### **13.6 Actuator functional test**

The actuator shall be subjected to a test to validate functional ability in accordance with the manufacturer's documented procedures. The test may be performed with or without the valve and/or control package.

The actuator shall, at a minimum, undergo two cycles, and the movement shall be smooth and controlled.

## **14 Surface protection**

Actuators, intermediate supports (including the internal surfaces), couplings and fasteners in contact with the environment shall be protected against corrosion in accordance with the manufacturer's standards, unless otherwise agreed.

Parts and equipment that have bare metallic surfaces shall be protected with a rust preventative that provides protection against corrosion in accordance with the manufacturer's standards, unless otherwise agreed.

## 15 Marking

Actuators shall be marked in accordance with the requirements of Table 3 or Table 4. Local regulatory requirements can specify additional marking.

Each actuator shall be provided with a nameplate(s) securely affixed and so located as to be easily accessible. The marking on the nameplate(s) shall be permanent and legible.

NOTE The purchaser can specify requirements for the marking of the actuator parts.

**Table 3 — Marking of electric actuators**

| No. | Marking                             | Application on            |
|-----|-------------------------------------|---------------------------|
| 1   | Manufacturer's name or trademark    | Actuator and/or nameplate |
| 2   | Model                               | Nameplate                 |
| 3   | Serial number                       | Nameplate                 |
| 4   | Supply voltage, phase and frequency | Nameplate                 |
| 5   | Voltage variation                   | Nameplate                 |
| 6   | Frequency variation                 | Nameplate                 |
| 7   | Hazardous area classification       | Nameplate                 |
| 8   | Year of manufacture                 | Nameplate                 |
| 9   | ISO 12490                           | Nameplate                 |

**Table 4 — Marking of pneumatic/hydraulic actuators**

| No. | Marking                                   | Application on                             |
|-----|---|--|
| 1   | Manufacturer's name or trademark          | Both actuator or accumulator and nameplate |
| 2   | Model                                     | Nameplate                                  |
| 3   | Serial number                             | Nameplate                                  |
| 4   | Maximum rated pressure                    | Nameplate                                  |
| 5   | Maximum operating pressure (if specified) | Nameplate                                  |
| 6   | Year of manufacture                       | Nameplate                                  |
| 7   | ISO 12490                                 | Nameplate                                  |

## 16 Preparation for shipment

All open ports shall be blanked off to protect the seal surfaces and threads. The mounting interface shall be protected to prevent mechanical damage. Actuators shall be packaged suitably to endure the intended shipping method.

## 17 Documentation

The documentation specified in Table 5 shall be provided to the purchaser with each actuator supplied.

**Table 5 — Required documentation**

| Item | Description                  | Electric actuators | Pneumatic/hydraulic actuators |
|------|------------------------------|--------------------|-------------------------------|
| 1    | Output torque data           | X                  | X                             |
| 2    | Circuit diagram              | X                  |                               |
| 3    | Pressure test, shell         |                    | X                             |
| 4    | Leak test, piston            |                    | X                             |
| 5    | Hazardous area certification | X                  | X                             |

Documentation shall be provided by the manufacturer in legible, retrievable and reproducible form and free of damage.

NOTE The purchaser can specify supplementary documentation in accordance with Annex B.

Documentations shall be retained by the manufacturer in accordance with Annex D.

## **Annex A** (informative)

### **Supplementary test requirements**

#### **A.1 Torque/thrust test**

##### **A.1.1 Electric actuators**

If specified, additional measurement of torque/thrust shall be carried out by agreement.

##### **A.1.2 Pneumatic/hydraulic actuators**

If specifying a torque/thrust test, the minimum and maximum supply pressures shall be specified, or the test pressure shall be established by agreement.

As a minimum, actuator torque/thrust shall be measured at the following positions, and in both directions:

- start of stroke;
- mid-stroke, or lowest torque/thrust position;
- end of stroke.

Torque/thrust shall be measured at additional positions to establish non-linear characteristics.

NOTE An additional four positions are suggested to adequately establish non-linear characteristics.

Torque/thrust testing shall be performed at the minimum and maximum supply pressures or at another test pressure by agreement.

The actuator torque/thrust shall not be below the design torque/thrust value, nor shall it exceed the valve MAST.

#### **A.2 Partial stroke test**

The actuator shall be energized and shall be moved to the predetermined position. The actuator shall stop, and shall return to its starting position.



## **Annex B** (informative)

### **Optional documentation**

Optional documentation includes the following:

- a) NDE records;
- b) hardness test report on pressure-containing parts;
- c) certificate of conformance to this International Standard;
- d) pressure test report (including pressure, test duration, test medium, and acceptance criteria);
- e) NDE personnel qualification records;
- f) coating/plating certification;
- g) NDE procedures;
- h) calibration records (purchaser to identify requirements for equipment when ordering);
- i) material inspection certificates in accordance with ISO 10474 or EN 10204 as applicable (the purchaser shall specify the type of certification, and for which parts, when ordering);
- j) design verification by certification body/agency;
- k) type approval by certification body/agency;
- l) drawings illustrating general arrangements;
- m) cross-sectional drawings with parts and materials list;
- n) current quality management system certificate
- o) verification of power requirements and consumption (electric actuators only);
- p) electrical integrity (electric actuators only);
- q) verification of control, indication and option functionality;
- r) type testing of enclosure protection.

## Annex C (informative)

### Purchasing guidelines

**Table C.1 — Actuator data sheet**

| Type                                     | Item | Subclause(s)       | Data required  |  |  |  |  |
|--|------|--------------------|--|--|--|--|--|
| General                                  | 1    | 6.2                | Actuator type  |  |  |  |  |
|  | 2    | 6.3                | Actuator configuration   |  |  |  |  |
|  | 3    | 6.4                | Action on loss of supply energy                                |  |  |  |  |
|  | 4    | 7.13               | Orientation  |  |  |  |  |
|  | 5    | 8.1.5 e), 8.1.6 c) | Operating temperature, min./max.                               |  |  |  |  |
|  | 6    | 8.1.5 e), 8.1.6 c) | Ambient temperature, min./max.                                 |  |  |  |  |
|  | 7    | A.2                | Partial stroke testing, % open / % closed                      |  |  |  |  |
|  | 8    | 10.2               | O-ring/other seal material                                     |  |  |  |  |
| Electric                                 | 9    | 8.1.5 a)           | Electrical source  |  |  |  |  |
|  | 10   | 8.1.5 a)           | Voltage, phase/frequency                                       |  |  |  |  |
|  | 11   | 8.1.5 b)           | Voltage variation  |  |  |  |  |
|  | 12   | 8.1.5 b)           | Frequency variation  |  |  |  |  |
|  | 13   | 8.1.5 c)           | Number of consecutive valve strokes                            |  |  |  |  |
|  | 14   | 8.1.5 d)           | Number of starts per hour                                      |  |  |  |  |
| Pneumatic/hydraulic                      | 15   | 8.1.6 b)           | Supply pressure, min./max./regulated                           |  |  |  |  |
|  | 16   | 8.1.6 f)           | Number of strokes from stored-pressure source                  |  |  |  |  |
|  | 17   | 10.2               | Commissioning fluid  |  |  |  |  |
|  | 18   | 8.1.6 a)           | Service fluid  |  |  |  |  |
|  | 19   | 8.1.6 a)           | Gas composition  |  |  |  |  |
|  | 20   | 10.2, 10.7         | ISO 15156 service  |  |  |  |  |
| Valve torque/thrust data open direction  | 21   | 8.1.2 a), 8.1.3 b) | Breakaway torque/thrust and corresponding sizing safety factor |  |  |  |  |
|  | 22   | 8.1.2 c), 8.1.3 b) | Run torque/thrust and corresponding sizing safety factor       |  |  |  |  |
|  | 23   | 8.1.2 d), 8.1.3 b) | Reseat torque/thrust and corresponding sizing safety factor    |  |  |  |  |
|  | 24   | 8.1.3 a)           | Operating time min./max.                                       |  |  |  |  |
|  | 25   | 8.1.2 e)           | MAST   |  |  |  |  |
|  | 26   | 8.1.2 b)           | Breakaway angle or % of stroke                                 |  |  |  |  |
| Valve torque/thrust data close direction | 27   | 8.1.2 a), 8.1.3 b) | Breakaway torque/thrust and corresponding sizing safety factor |  |  |  |  |
|  | 28   | 8.1.2 c), 8.1.3 b) | Run torque/thrust and corresponding sizing safety factor       |  |  |  |  |
|  | 29   | 8.1.2 d), 8.1.3 b) | Reseat torque/thrust and corresponding sizing safety factor    |  |  |  |  |
|  | 30   | 8.1.3 a)           | Operating time min./max.                                       |  |  |  |  |
|  | 31   | 8.1.2 e)           | MAST   |  |  |  |  |
|  | 32   | 8.1.2 b)           | Breakaway angle or % of stroke                                 |  |  |  |  |
| Valve data                               | 33   | —                  | Valve type   |  |  |  |  |
|  | 34   | —                  | Degrees of travel or length of stroke                          |  |  |  |  |
|  | 35   | 8.1.4 a)           | Valve stem dimensions  |  |  |  |  |
|  | 36   | 8.1.4 b)           | Pitch/lead/number of starts/RH or LH                           |  |  |  |  |
|  | 37   | 8.1.4 c)           | Stem key dimensions: length/width/thickness                    |  |  |  |  |
|  | 38   | 8.1.4 d)           | Mounting pattern dimensions                                    |  |  |  |  |
|  | 39   | 7.13               | Installation orientation                                       |  |  |  |  |
| Optional equipment                       | 40   | —                  |  |  |  |  |  |

**Table C.2 — Summary of information that shall be provided by purchaser and/or manufacturer**

| Subclause   | Information  | Provider <sup>a</sup> |
|-------------|--|-----------------------|
| 4.27        | Maximum operating temperature  | P                     |
| 4.27        | Maximum design temperature   | M/S                   |
| 4.28        | Maximum operating temperature  | P                     |
| 4.30        | Minimum operating temperature  | P                     |
| 4.29        | Minimum design temperature   | M/S                   |
| 4.30        | Minimum operating temperature  | P                     |
| 6.1         | Range of stroke for reduced stroke actuator  | P                     |
| 6.2.1       | AC or DC power source  | P                     |
| 6.2.3       | Selection of the hydraulic fluid   | A                     |
| 7.1 a)      | Design pressure to be used for the design of the pressure-containing parts   | M/S                   |
| 7.1 b)      | Maximum rated pressure   | M/S                   |
| 7.2         | Use of other international design codes  | A                     |
| 7.2         | Use of proprietary design method   | A                     |
| 7.10        | Requirement for locking device   | P                     |
| 7.13        | Actuator that is required to have single orientation capability may be supplied                                      | P                     |
| 7.13        | Details regarding installed orientation of the actuated valve assembly   | P                     |
| 8.1.1       | MAST and maximum torque/thrust are compared to ensure compatibility of design  | P                     |
| 8.1.2 a)-e) | Valve torque and/or thrust data  | VM                    |
| 8.1.2       | Other specific torque or thrust data   | VM                    |
| 8.1.2       | Input thrust and/or torque for linear valves   | VM                    |
| 8.1.3 a)-b) | Operating time and safety factor   | P                     |
| 8.1.4 a)-d) | All relevant valve dimensions  | VM                    |
| 8.1.5 a)-h) | Electric actuator data   | P                     |
| 8.1.6 a)-f) | Pneumatic/hydraulic actuator data  | P                     |
| 8.1.6       | Regulation of maximum supply pressure by the manufacturer or supplier for the purpose of meeting sizing requirements | A                     |
| 9.2         | Alternative means of limiting supply pressure  | A                     |
| 10.2        | Commissioning fluids and service   | P                     |
| 10.3.2      | The chemical composition of other materials of pressure-containing parts subject to welding                          | A                     |
| 10.3.4      | The chemical composition of other materials of pressure-containing parts   | A                     |
| 10.4        | Toughness requirements for other materials   | A                     |
| 10.7        | Requirement for ISO 15156 (all parts)  | P                     |
| 11.5        | Weld repair of forgings and plates to correct manufacturing defects  | A                     |
| 12.1.2      | Requirement for welds on pressure containing parts subjected to additional NDE                                       | P                     |
| 12.1.2      | Additional NDE method and acceptance criteria, when specified  | A                     |
| 12.1.3      | Requirement for welds on mechanically loaded parts subjected to additional NDE                                       | P                     |
| 12.1.3      | Additional NDE method and acceptance criteria, when specified  | A                     |
| 13.1        | Requirement for supplementary tests  | P                     |
| 13.2        | Test pressure, if not in accordance with 7.2   | A                     |
| 13.4        | Additional torque/thrust testing   | P                     |

**Table C.2** (continued)

| Subclause    | Information  | Provider <sup>a</sup> |
|--------------|--|-----------------------|
| 13.5.1       | Gearbox performance data, when not validated by type test and calculation  | A                     |
| 13.5.1       | Torque-stroke profile of scotch-yoke gearbox   | M/S                   |
| 13.5.1       | Optional production testing for combination of electric multi-turn actuator and gearboxes  | A                     |
| 13.5.2.1     | When limited by ability to functionally test, the stall torque shall be reported based on calculation  | A                     |
| 13.5.2.2     | Torque-limiting device(s) may be set to an operational value below 100 %   | A                     |
| Table 5      | Documentation  | M/S                   |
| Annex A      | Supplementary test requirements  | P                     |
| Annex B      | Optional documentation requirements  | P or A                |
| Annex C      | Purchasing guidelines  | P                     |
| Annex D      | Record retention   | P, M/S or A           |
| <sup>a</sup> | M/S indicates information that should be supplied by manufacturer/supplier;<br>P indicates information that should be supplied by purchaser;<br>A indicates information that should be established by agreement;<br>VM indicates valve manufacturer. |                       |

## Annex D (normative)

### Record retention

Documentation, where applicable and as listed in Table D.1, shall be retained by the manufacturer for a minimum of ten years following the date of manufacture.

NOTE Purchaser or regulatory requirements can specify a longer record retention period.

**Table D.1 — Record retention**

| Item | Description  | Electric actuators | Pneumatic/hydraulic actuators |
|------|--|--------------------|-------------------------------|
| 1    | Bill of materials  | X <sup>a</sup>     | X                             |
| 2    | Design documentation   | X                  | X                             |
| 3    | Hazardous area certification   | X                  |                               |
| 4    | Contract/project documentation   | X                  | X                             |
| 5    | Sizing calculations/confirmations  | X                  | X                             |
| 6    | Welding procedure specification (WPS)  |                    | X                             |
| 7    | Weld procedure qualification record (PQR)  |                    | X                             |
| 8    | Welder performance qualification (WPQ)   |                    | X                             |
| 9    | Qualification records of NDE personnel   |                    | X                             |
| 10   | Records of test equipment calibration  | X                  | X                             |
| 11   | Material test report for pressure-containing parts, traceable to the unique serial number  |                    | X                             |
| 12   | Material test report for spring and spring canister, traceable to the unique serial number   |                    | X                             |
| 13   | Serial number  |                    | X                             |
| 14   | Certificate of compliance to ISO 15156 (all parts)   |                    | A <sup>b</sup>                |
| 15   | Circuit diagram  | X                  |                               |
| 16   | Installation, commissioning and maintenance instructions   | X                  | X                             |
| 17   | Production test certificate, including<br>— output torque<br>— stroking times<br>— pressure test, shell<br>— pressure test, piston | X                  | X                             |
| 18   | Coating certificate  |                    | X                             |
| 19   | Cleanliness test report  |                    | H <sup>c</sup>                |
| 20   | Compliance with local directives and regulations<br>For example, including but not limited to PED, ATEX, ASME, CRN                 | A                  | A                             |
| 21   | NDE report<br>— RT<br>— PT<br>— MT<br>— UT   | A                  | A                             |

<sup>a</sup> X indicates mandatory.

<sup>b</sup> A indicates mandatory if applicable to the specific design.

<sup>c</sup> H indicates hydraulic actuators only.

## Annex E (informative)

### Typical torque/thrust curves

The torque/thrust curves represented below are typical of the actuators discussed in this International Standard.

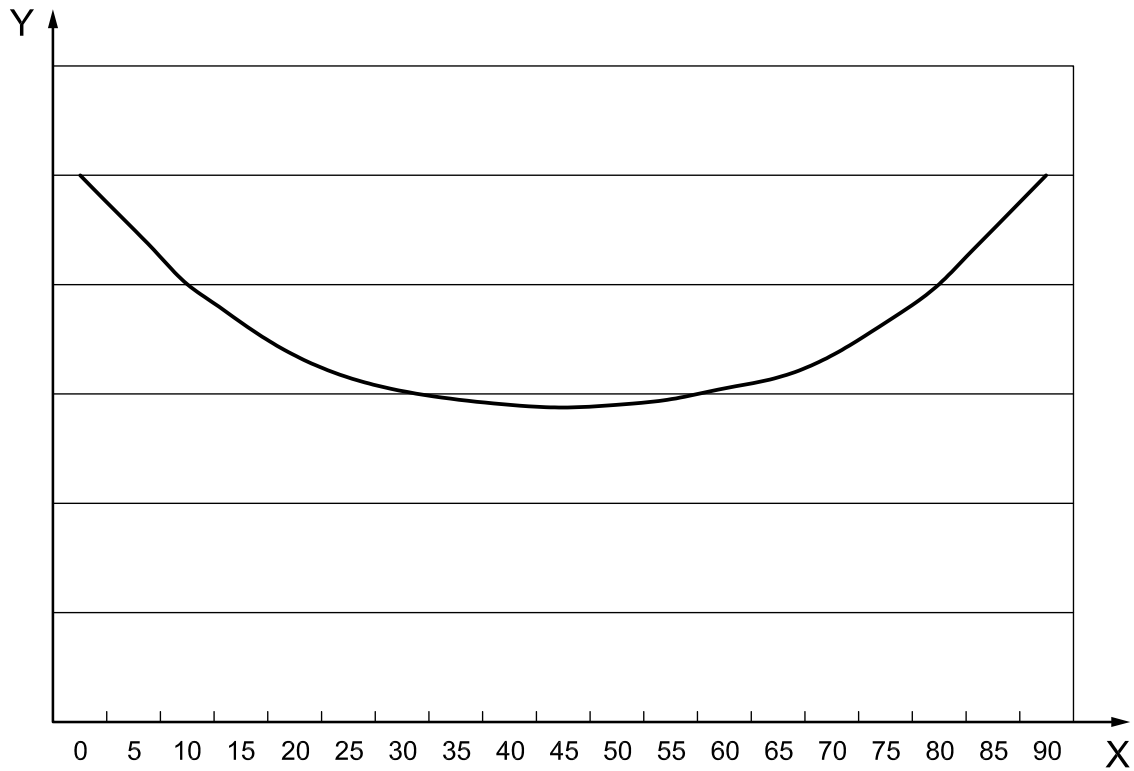

**Key**

X angular rotation, expressed in degrees

Y torque value

**Figure E.1 — Double-acting, scotch-yoke actuator**

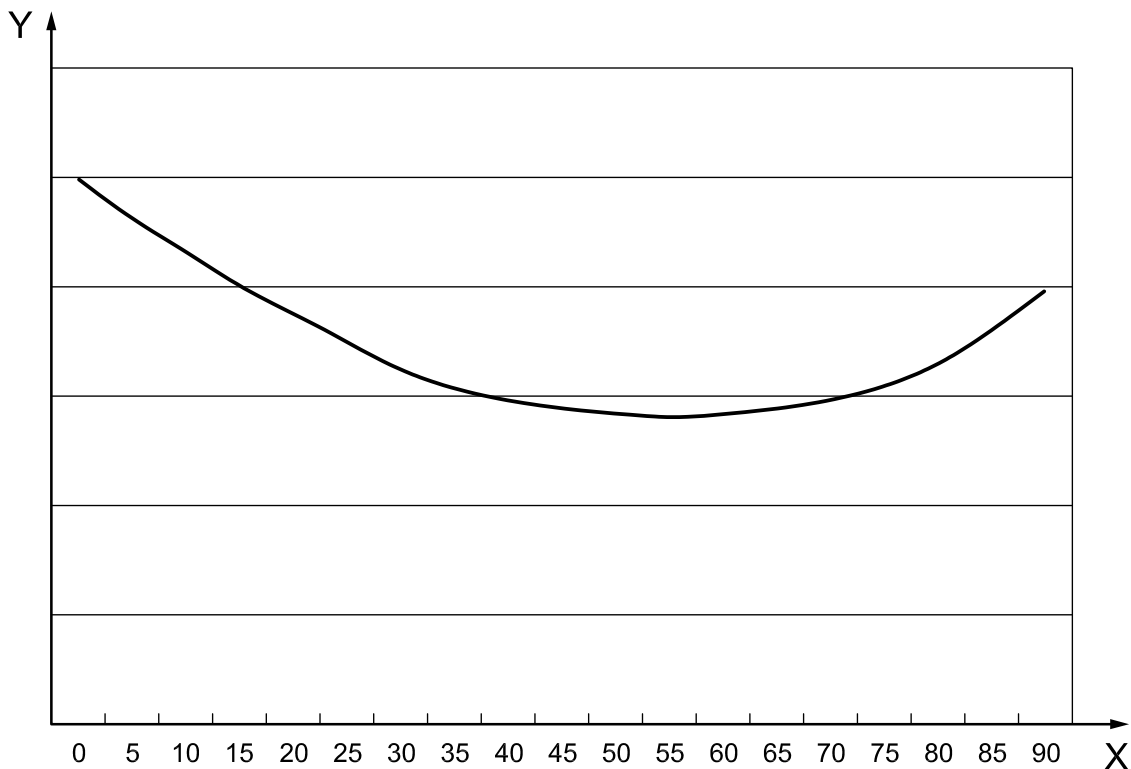

**Key**  
 X angular rotation, expressed in degrees  
 Y torque value

**Figure E.2 — Double-acting, canted scotch-yoke actuator**

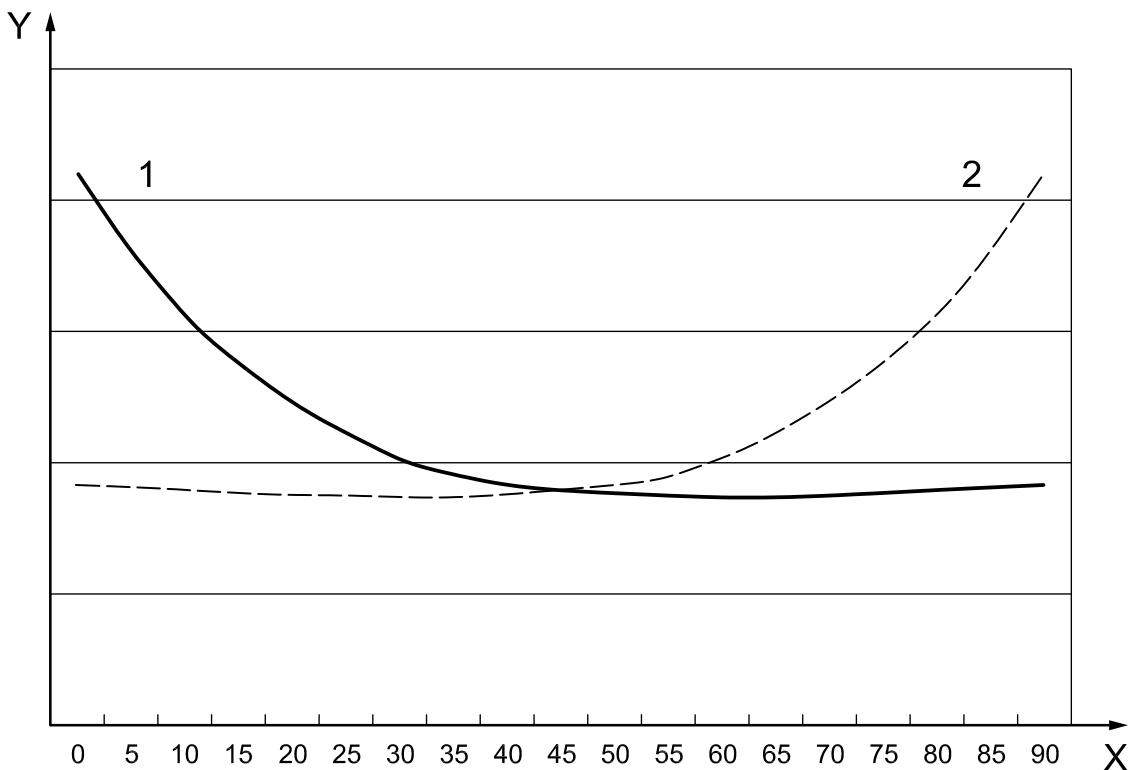

**Key**  
 1 air  
 2 spring  
 X angular rotation, expressed in degrees  
 Y torque value

**Figure E.3 — Single-acting, spring return, scotch-yoke actuator**

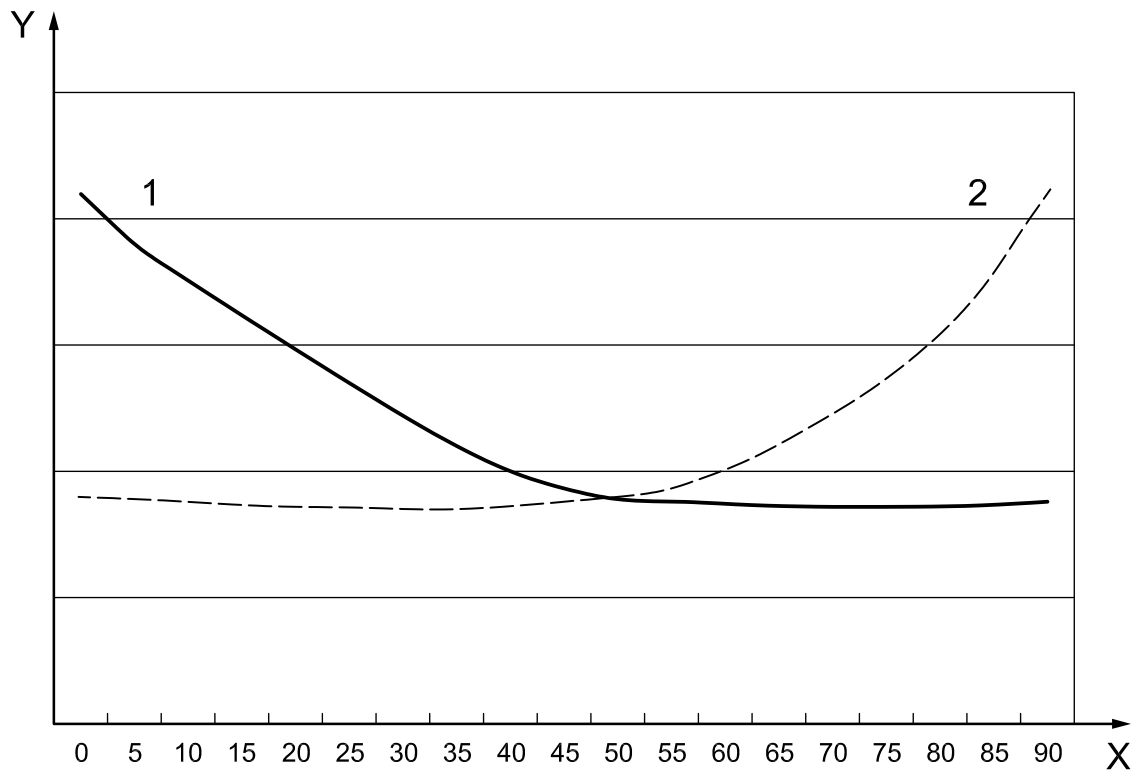

**Key**

- 1 air
- 2 spring

X angular rotation, expressed in degrees

Y torque value

**Figure E.4 — Single-acting, spring return, canted scotch-yoke actuator**



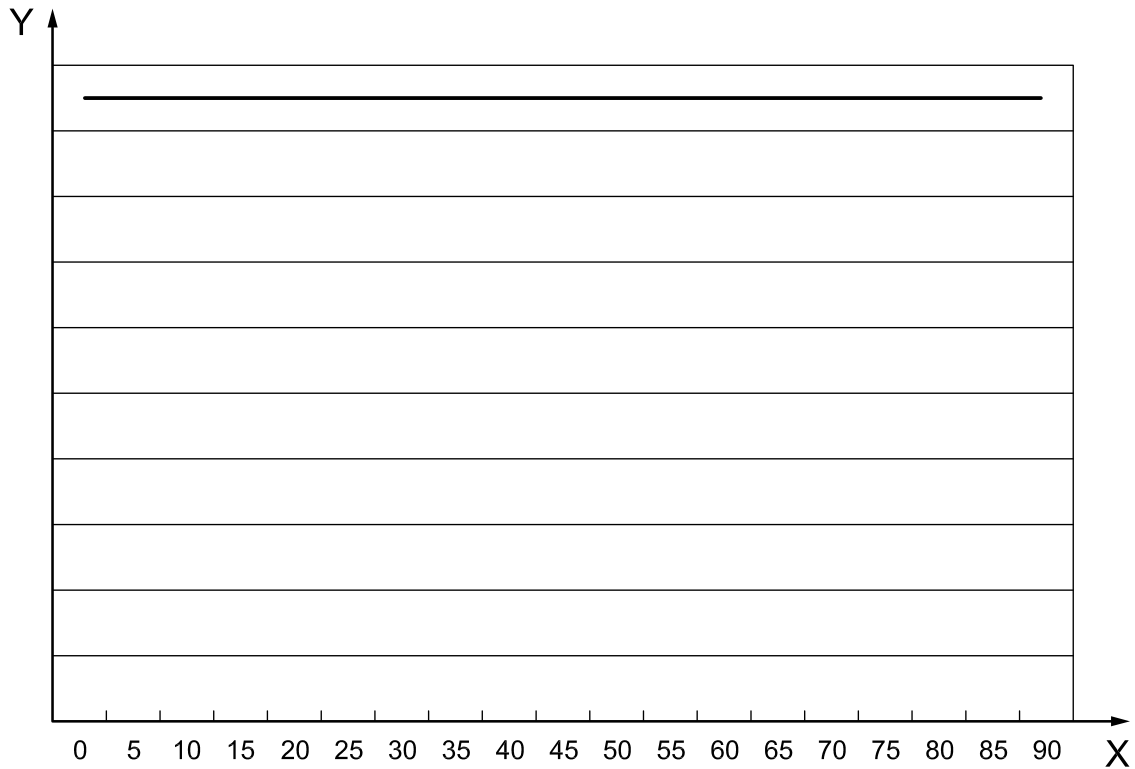

**Key**

- X angular rotation, expressed in degrees
- Y torque value

**Figure E.5 — Rack and pinion actuator**

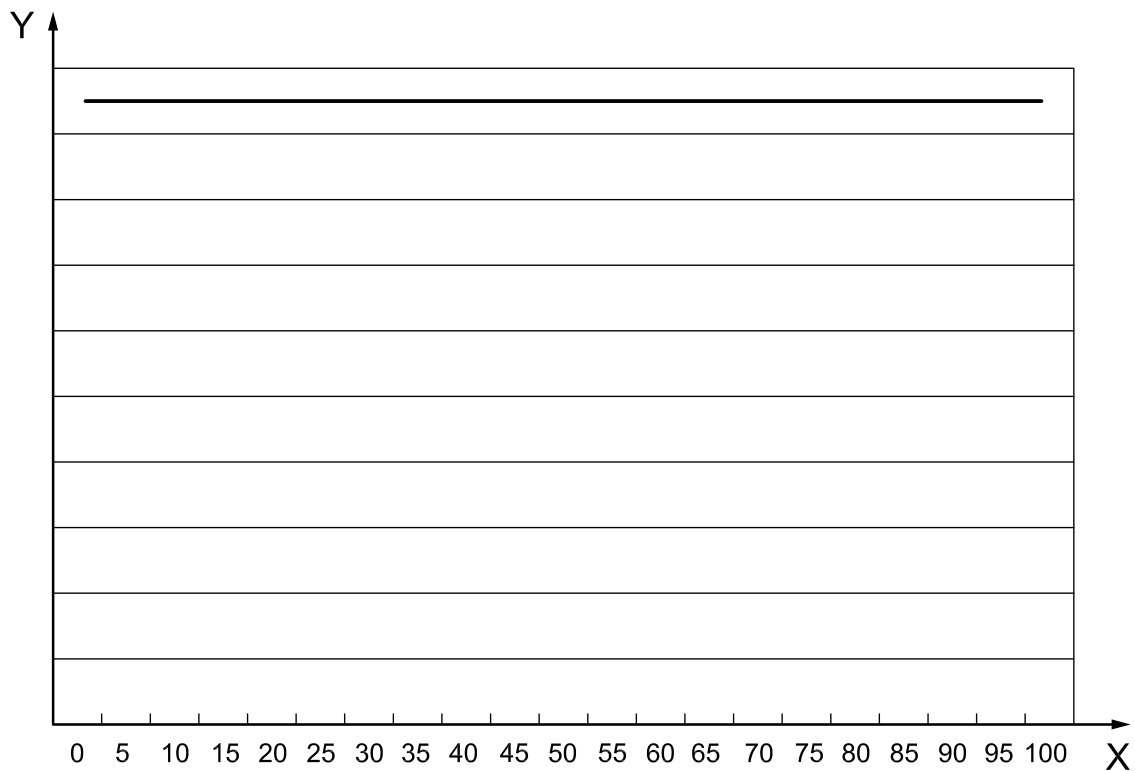

**Key**

- X percent of full stroke
- Y torque value

**Figure E.6 — Bevel gear actuator**

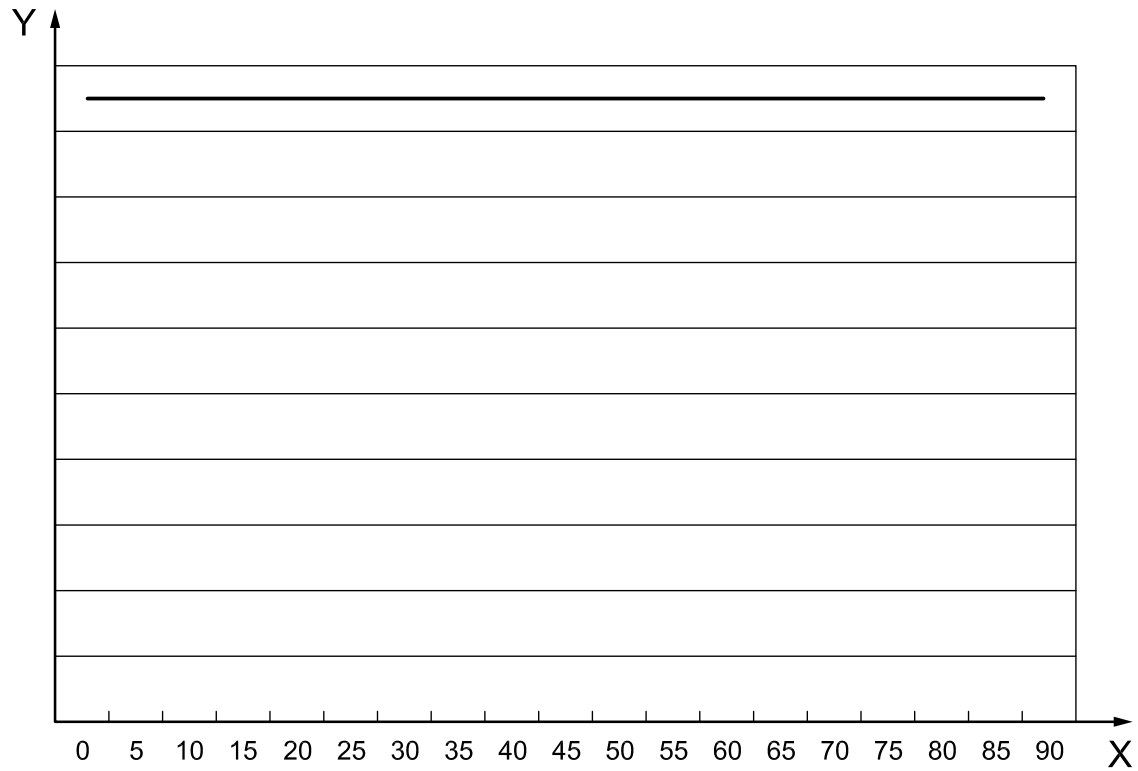

**Key**

X angular rotation, expressed in degrees

Y torque value

**Figure E.7 — Linear actuator**

## Bibliography

- [1] ISO 8573-1:2010, *Compressed air — Part 1: Contaminants and purity classes*
- [2] ISO 13623, *Petroleum and natural gas industries — Pipeline transportation systems*
- [3] ISO/TS 29001, *Petroleum, petrochemical and natural gas industries — Sector-specific quality management systems — Requirements for product and service supply organizations*
- [4] API Spec 6D, *Pipeline valves*, twenty-third edition, April 2008
- [5] EN 13906 (all parts), *Cylindrical helical springs made from round wire and bar — Calculation and design*
- [6] MSS SP-25, *Standard Marking System for Valves, Fittings, Flanges and Unions*





# British Standards Institution (BSI)

BSI is the national body responsible for preparing British Standards and other standards-related publications, information and services.

BSI is incorporated by Royal Charter. British Standards and other standardization products are published by BSI Standards Limited.

## About us

We bring together business, industry, government, consumers, innovators and others to shape their combined experience and expertise into standards-based solutions.

The knowledge embodied in our standards has been carefully assembled in a dependable format and refined through our open consultation process. Organizations of all sizes and across all sectors choose standards to help them achieve their goals.

## Information on standards

We can provide you with the knowledge that your organization needs to succeed. Find out more about British Standards by visiting our website at [bsigroup.com/standards](http://bsigroup.com/standards) or contacting our Customer Services team or Knowledge Centre.

## Buying standards

You can buy and download PDF versions of BSI publications, including British and adopted European and international standards, through our website at [bsigroup.com/shop](http://bsigroup.com/shop), where hard copies can also be purchased.

If you need international and foreign standards from other Standards Development Organizations, hard copies can be ordered from our Customer Services team.

## Subscriptions

Our range of subscription services are designed to make using standards easier for you. For further information on our subscription products go to [bsigroup.com/subscriptions](http://bsigroup.com/subscriptions).

With **British Standards Online (BSOL)** you'll have instant access to over 55,000 British and adopted European and international standards from your desktop. It's available 24/7 and is refreshed daily so you'll always be up to date.

You can keep in touch with standards developments and receive substantial discounts on the purchase price of standards, both in single copy and subscription format, by becoming a **BSI Subscribing Member**.

**PLUS** is an updating service exclusive to BSI Subscribing Members. You will automatically receive the latest hard copy of your standards when they're revised or replaced.

To find out more about becoming a BSI Subscribing Member and the benefits of membership, please visit [bsigroup.com/shop](http://bsigroup.com/shop).

With a **Multi-User Network Licence (MUNL)** you are able to host standards publications on your intranet. Licences can cover as few or as many users as you wish. With updates supplied as soon as they're available, you can be sure your documentation is current. For further information, email [bsmusales@bsigroup.com](mailto:bsmusales@bsigroup.com).

## BSI Group Headquarters

389 Chiswick High Road London W4 4AL UK

## Revisions

Our British Standards and other publications are updated by amendment or revision.

We continually improve the quality of our products and services to benefit your business. If you find an inaccuracy or ambiguity within a British Standard or other BSI publication please inform the Knowledge Centre.

## Copyright

All the data, software and documentation set out in all British Standards and other BSI publications are the property of and copyrighted by BSI, or some person or entity that owns copyright in the information used (such as the international standardization bodies) and has formally licensed such information to BSI for commercial publication and use. Except as permitted under the Copyright, Designs and Patents Act 1988 no extract may be reproduced, stored in a retrieval system or transmitted in any form or by any means – electronic, photocopying, recording or otherwise – without prior written permission from BSI. Details and advice can be obtained from the Copyright & Licensing Department.

## Useful Contacts:

### Customer Services

**Tel:** +44 845 086 9001

**Email (orders):** [orders@bsigroup.com](mailto:orders@bsigroup.com)

**Email (enquiries):** [cservices@bsigroup.com](mailto:cservices@bsigroup.com)

### Subscriptions

**Tel:** +44 845 086 9001

**Email:** [subscriptions@bsigroup.com](mailto:subscriptions@bsigroup.com)

### Knowledge Centre

**Tel:** +44 20 8996 7004

**Email:** [knowledgecentre@bsigroup.com](mailto:knowledgecentre@bsigroup.com)

### Copyright & Licensing

**Tel:** +44 20 8996 7070

**Email:** [copyright@bsigroup.com](mailto:copyright@bsigroup.com)



...making excellence a habit.™