

BS ISO 12488-1:2012



BSI Standards Publication

Cranes — Tolerances for wheels and travel and traversing tracks

Part 1: General

bsi.

...making excellence a habit.™

National foreword

This British Standard is the UK implementation of ISO 12488-1:2012. It supersedes BS ISO 12488-1:2005 which is withdrawn.

The UK participation in its preparation was entrusted by Technical Committee MHE/3, Cranes and derricks, to Subcommittee MHE/3/3, Bridge, gantry and slewing jib cranes.

A list of organizations represented on this committee can be obtained on request to its secretary.

This publication does not purport to include all the necessary provisions of a contract. Users are responsible for its correct application.

© The British Standards Institution 2012

Published by BSI Standards Limited 2012

ISBN 978 0 580 72789 4

ICS 53.020.20

Compliance with a British Standard cannot confer immunity from legal obligations.

This British Standard was published under the authority of the Standards Policy and Strategy Committee on 31 July 2012.

Amendments issued since publication

Amd. No.	Date	Text affected
----------	------	---------------

INTERNATIONAL STANDARD

ISO
12488-1

Second edition
2012-07-01

Cranes — Tolerances for wheels and travel and traversing tracks

Part 1: General

*Appareils de levage à charge suspendue — Tolérances des galets et
des voies de translation et de direction —*

Partie 1: Généralités



Reference number
ISO 12488-1:2012(E)

© ISO 2012



COPYRIGHT PROTECTED DOCUMENT

© ISO 2012

All rights reserved. Unless otherwise specified, no part of this publication may be reproduced or utilized in any form or by any means, electronic or mechanical, including photocopying and microfilm, without permission in writing from either ISO at the address below or ISO's member body in the country of the requester.

ISO copyright office
Case postale 56 • CH-1211 Geneva 20
Tel. + 41 22 749 01 11
Fax + 41 22 749 09 47
E-mail copyright@iso.org
Web www.iso.org

Published in Switzerland

Contents		Page
Foreword		iv
Introduction		v
1 Scope		1
2 Normative references		1
3 Terms and definitions		1
4 Symbols		2
5 Classification of tolerances		3
6 Tolerances		3
6.1 General		3
6.2 Thermal effects		3
6.3 Application of vertical out-of-plane tolerance		3
6.4 Construction tolerances		4
6.5 Operational tolerances		4
Bibliography		20

Foreword

ISO (the International Organization for Standardization) is a worldwide federation of national standards bodies (ISO member bodies). The work of preparing International Standards is normally carried out through ISO technical committees. Each member body interested in a subject for which a technical committee has been established has the right to be represented on that committee. International organizations, governmental and non-governmental, in liaison with ISO, also take part in the work. ISO collaborates closely with the International Electrotechnical Commission (IEC) on all matters of electrotechnical standardization.

International Standards are drafted in accordance with the rules given in the ISO/IEC Directives, Part 2.

The main task of technical committees is to prepare International Standards. Draft International Standards adopted by the technical committees are circulated to the member bodies for voting. Publication as an International Standard requires approval by at least 75 % of the member bodies casting a vote.

Attention is drawn to the possibility that some of the elements of this document may be the subject of patent rights. ISO shall not be held responsible for identifying any or all such patent rights.

ISO 12488-1 was prepared by Technical Committee ISO/TC 96, *Cranes*, Subcommittee SC 8, *Jib cranes*.

This second edition cancels and replaces the first edition (ISO 12488-1:2005), which has been technically revised. It also incorporates the Technical Corrigendum ISO 12488-1:2005/Cor 1:2008.

ISO 12488 consists of the following parts, under the general title *Cranes — Tolerances for wheels and travel and traversing tracks*:

- *Part 1: General*
- *Part 4: Jib cranes*

Introduction

This part of ISO 12488 establishes requirements and gives guidance and design rules that reflect the present state of the art in the field of crane machine design. The rules given represent good design practice that ensures fulfilment of essential safety requirements and adequate service life of components. Deviation from these rules normally leads to increased risks or reduction of service life, but it is acknowledged that new technical innovations, materials etc. may provide new solutions that result in equal or improved safety and durability.

Cranes — Tolerances for wheels and travel and traversing tracks —

Part 1: General

1 Scope

This part of ISO 12488 specifies tolerances for construction assemblies and operational conditions of cranes and associated crane tracks as defined in ISO 4306-1. The purpose of the requirements in this part of ISO 12488 is to promote safe operation and achievement of the expected life of components by the elimination of excessive load effects due to deviations or misalignments from the normal dimensions of the structure.

Tolerances given are extreme values. The elastic deformations due to load effects are outside the scope of this part of ISO 12488. These will need to be taken into account at the design stage using other criteria to achieve the intended operation and performance.

Specific values for particular crane types are given in other parts of ISO 12488.

2 Normative references

The following referenced documents are indispensable for the application of this document. For dated references, only the edition cited applies. For undated references, the latest edition of the referenced document (including any amendments) applies.

ISO 286-2, *Geometrical product specifications (GPS) — ISO code system for tolerances on linear sizes — Part 2: Tables of standard tolerance classes and limit deviations for holes and shafts*

ISO 1101, *Geometrical Product Specifications (GPS) — Geometrical tolerancing — Tolerances of form, orientation, location and run-out*

ISO 4306-1, *Cranes — Vocabulary — Part 1: General*

3 Terms and definitions

For the purposes of this document, the following terms and definitions apply.

3.1

construction tolerance

amount by which a specific dimension is permitted to vary, resulting from the assembly of the complete crane and its tracks, in new, modified, rebuilt or repaired buildings, before operational use

NOTE 1 This applies to new build or repaired or modified cranes and tracks.

NOTE 2 The amount is given either by the absolute value of the difference between the limits of size, or by the allowable geometric variation.

3.2

operational tolerance

amount by which a specific dimension is permitted to vary, resulting from the use of the crane and its tracks

NOTE The amount is given either by the absolute value of the difference between the limits of size, or by the allowable geometric variation.

4 Symbols

A	Tolerance of the span, related to the rail centre of travelling or traversing tracks, at each point of the track or to the wheel centre of crabs or cranes
B	Tolerance of the horizontal straightness, in ground plan, at each point of the travelling track
b	Tolerance of horizontal straightness related to a test length of 2 m in ground plan, (sample value) at each point of the rail head
C	Tolerance of straightness related to the height of the crane rail centre at each point of the travelling track
c	Tolerance of straightness related to a test length of 2 m (sample value) at each point of height of the crane rail
a	Centre-to-centre distance between the horizontal guide rollers, in longitudinal direction of rail
e	Centre-to-centre distance between two wheels or bogeys, in longitudinal direction of rail
h_F	Distance between the top edge of a rail and the bottom edge of horizontal guide rollers
S	Span from centre to centre of the rail
0/00	Angle of inclination expressed as vertical points per horizontal thousand
D	Wheel diameter
E	Height tolerance related to opposite measuring points at right angles to each point of the track
F	Parallelism tolerance of end stops or buffers
G	Angularity tolerance related to rail cross-section with plane surface
H_F	Vertical offset of a welded connection
H_S	Horizontal offset of a rail head
K	Parallelism tolerance of a rail with reference to the web
ΔD	Diameter tolerance for coupled and independently driven crane/cab wheels
Δe	Tolerance of the wheel base in ground plan
ΔF	Alignment tolerance of guide rollers in ground plan
Δhr	Height tolerance of the points of wheel contact
ΔN	Tolerance of parallel offset of the wheels in ground plan
α_F	Axle tolerance of parallelism of guide rollers across the track
β_F	Axle tolerance of parallelism of guide rollers across the track
ϕk	Axle tolerance of parallelism in a ground plan of the hole (inclination of axis)
ϕr	Axle tolerance of parallelism in a ground plan of the wheel (inclination of wheel)
τk	Axle tolerance parallelism in elevation of the hole (axle camber)
τr	Axle tolerance of parallelism in elevation of the wheel (wheel camber)
b_s	Tolerance of straightness related to a test length of 1 m adjacent to a welded rail joint
c_h	Tolerance of straightness related to a test length of 2 m adjacent to a welded rail joint

These symbols and their meanings are applicable to all parts of ISO 12488.

Where symbols for construction tolerances are also applicable to operational tolerances (e.g. in operator instructions), the suffix *w* is used (e.g. A_w , B_w , C_w , E_w).

Where necessary, an additional suffix may be added, for example,

A_{w1}	operational tolerance for travelling tracks,
A_{w2}	operational tolerances for traversing tracks,
A_{w3}	operational tolerances for cranes,
A_{w4}	operational tolerances for crabs.

5 Classification of tolerances

The main criterion for determining the class of tolerance is the total amount of travel throughout the life of the crane; however, system sensitivity shall be considered along with the class of tolerance as given in other parts of ISO 12488.

NOTE In the context of this part of ISO 12488, system sensitivity is considered to be the amount of reaction of the system in terms of load effect resulting from the tolerance considered as unintentional displacement (see ISO 8686-1:1989, 6.1.5). In the case of highly sensitive systems, it could be appropriate to select a higher tolerance class than that shown in Table 1.

Table 1 — Tolerance classes

Tolerance class	Limits of travelling and traversing distance
	km
1	$50\,000 \leq L$
2	$10\,000 \leq L < 50\,000$
3	$L < 10\,000$, for stationary erected tracks
4	Temporarily erected tracks for building and erection purposes

NOTE L is calculated as the product of the normal travel speed and the specified working time of the relevant travel/traverse mechanism, either by application of customer specified values or through reference to the classification of the mechanism (see ISO 4301-1).

6 Tolerances

6.1 General

The tolerances for the various classes and parameters shall be as given in Tables 2, 3, 4, 5, 6 and 7.

6.2 Thermal effects

The tolerances given in Tables 2, 3, 4, 5, 6 and 7 shall be used for an ambient temperature of 20°C. Where the average ambient temperature for the operational position of the crane differs from 20°C, the tolerances shall be adjusted accordingly.

6.3 Application of vertical out-of-plane tolerance

The tolerance Δ_{hr} given in Tables 4 and 5 for the vertical out-of-plane displacement of a corner of rail wheel of a crane or crane crab, and the corresponding tolerances for tracks given in Tables 2 and 3 are valid for rigid structures travelling or traversing on the rails, i.e. for box beam structures of main girders, crabs or portals. For frames built from open sections, the tolerances used may be one or two classes lower.

6.4 Construction tolerances

6.4.1 General

The measurements shall be taken in the unloaded condition with the crane and its associated tracks supported in the manner in which they will be operated. Tables 2 to 6 show the appropriate tolerances.

If technical documentation requires a means for differentiation of the tolerances, a suffix shall be added to the tolerance symbol, corresponding to the relevant table in this part of ISO 12488.

EXAMPLE A_2 is the construction tolerances for travelling tracks as per Table 2.

6.4.2 Rail joints

Construction tolerances shall be in accordance with Table 6.

6.5 Operational tolerances

The operational tolerances given in Table 7 shall be measured with the crane in the unloaded condition.

NOTE Tolerances in excess of those shown in Table 7 can result in unacceptable ride characteristics and additional stresses, leading to increased wear on rails, wheels, guide rollers etc., and possible damage to the supporting structure. If any measurements are beyond the tolerances in Table 7, then investigations should be undertaken by a competent engineer and the appropriate action taken.

Table 2 — Construction tolerances for travelling tracks of tolerance classes 1 to 4

Tolerance parameter		Tolerance				Unit	
Symbol	Description with respect of this table	Graphical representation	Class 1	Class 2	Class 3	Class 4	
<i>A</i>	Tolerance of span <i>S</i> of the crane rails related to rail centre at each point of travelling track	<p>$+A = S_{\max} - S$ $-A = S_{\min} - S$</p>	± 3 Valid for all spans $S \leq 16$ m $\pm[3 + 0,25(S-16)]$ ± 10 max. Valid for spans $S > 16$ m, <i>S</i> in metres	± 5 Valid for all spans $S \leq 16$ m $\pm[5 + 0,25(S-16)]$ ± 15 max. Valid for spans $S > 16$ m, <i>S</i> in metres	± 8 Valid for all spans $S \leq 16$ m $\pm[8 + 0,25(S-16)]$ ± 20 max. Valid for spans $S > 16$ m, <i>S</i> in metres	$\pm 12,5$ Valid for all spans $S \leq 16$ m $\pm[12,5 + 0,25(S-16)]$ ± 25 max. Valid for spans $S > 16$ m, <i>S</i> in metres	mm
<i>B</i>	Tolerance of horizontal straightness of rail head at each point of travelling track	<p>Position of crane rail in ground plan</p>	± 5	± 10	± 20	± 40	mm
<i>b</i>	Tolerance of horizontal straightness related to test length of 2 000 mm (sample value) at each point of rail head		1	1	2	4	mm
<i>C</i>	Tolerance of straightness related to height of crane rail centre at each point of travelling track	<p>Height of crane rail (axial slope)</p>	± 5	± 10	± 20	± 40	mm
<i>c</i>	Tolerance of straightness related to test length of 2 000 mm (sample value) at each point of height of crane rail		1	2	4	8	mm
<i>E</i>	Tolerance of height related to opposite measuring points at right angles at each point of travelling track	<p>Height of travelling track (lateral slope)</p>	$\pm 0,5S$ <i>S</i> in metres $E \leq E_{\max}$ ± 5 max.	$\pm S$ <i>S</i> in metres $E \leq E_{\max}$ ± 10 max.	$\pm 2S$ <i>S</i> in metres $E \leq E_{\max}$ ± 20 max.	$\pm 4S$ <i>S</i> in metres $E \leq E_{\max}$ ± 40 max.	mm

Table 2 (continued)

Symbol	Description with respect of this table	Tolerance parameter	Tolerance				Unit
			Class 1	Class 2	Class 3	Class 4	
<i>F</i>	Tolerance of parallelism of end stops or buffers on travelling track at right angles to longitudinal axis with parallelism symbol //	Position in a ground plan (datum symbol in accordance with ISO 1101) 	$\pm 0,8S$ ± 8 max. <i>S</i> in metres	$\pm S$ ± 10 max. <i>S</i> in metres	$\pm 1,25S$ $\pm 12,5$ max. <i>S</i> in metres	$\pm 1,6S$ ± 16 max. <i>S</i> in metres	mm
<i>G</i> (see Table 3)	Tolerance of angularity related to crane rail cross-section at each point of travelling track with angularity symbol \angle		4	6	9	12	0/00
Δhr	Height tolerance of points of wheel contact of each point of travelling track		$0,5S$ or $0,5e$ 5 max. <i>e</i> and <i>S</i> in metres, insert <i>e</i> or <i>S</i> , whichever is the least	$1,0S$ or $1,0e$ 10 max. <i>e</i> and <i>S</i> in metres, insert <i>e</i> or <i>S</i> , whichever is the least	$1,6S$ or $1,6e$ 16 max. <i>e</i> and <i>S</i> in metres, insert <i>e</i> or <i>S</i> , whichever is the least	$2,0S$ or $2,0e$ 20 max. <i>e</i> and <i>S</i> in metres, insert <i>e</i> or <i>S</i> , whichever is the least	mm
<i>K</i>	Tolerance of parallelism of crane rail to web at each point of travelling track	r_{min} = smallest thickness of web 	$\pm 0,5r_{min}$				mm

Table 3 — Construction tolerances for traversing tracks of tolerance classes 1 to 4

Tolerance parameter		Tolerance				Unit	
Symbol	Description with respect to this table	Graphical representation	Class 1	Class 2	Class 3	Class 4	
<i>A</i>	Tolerance of span <i>S</i> of crab rails related to rail centre at each point of traversing track		±3 Valid for all spans $S \leq 16$ m	±5 Valid for all spans $S \leq 16$ m	±8 Valid for all spans $S \leq 16$ m	±12,5 Valid for all spans $S \leq 16$ m	mm
<i>b</i>	Tolerance of horizontal straightness related to test length of 2 000 mm (sample value) at each point of rail head		1	1	2	4	mm
<i>E</i>	Tolerance of height related to opposite measuring points at right angles at each point of traversing track		±3,2 Valid for all spans $S \leq 2$ m ±1,6 <i>S</i> $E \leq E_{max}$ <i>S</i> in metres, valid for $S > 2$ m ±6,3 max.	±4,2 Valid for all spans $S \leq 2$ m ±2 <i>S</i> $E \leq E_{max}$ <i>S</i> in metres, valid for $S > 2$ m ±8 max.	±5 Valid for all spans $S \leq 2$ m ±2,5 <i>S</i> $E \leq E_{max}$ <i>S</i> in metres, valid for $S > 2$ m ±10 max.	±6,3 Valid for all spans $S \leq 2$ m ±3,2 <i>S</i> $E \leq E_{max}$ <i>S</i> in metres, valid for $S > 2$ m ±12,5 max.	mm
Δhr	Height tolerance of points of wheel contact at each point of traversing track		1,6 Valid for all spans $S \leq 2$ m 0,8 <i>S</i> $\Delta hr \leq \Delta hr_{max}$ <i>S</i> in metres, valid for $S > 2$ m 3,2 max.	2 Valid for all spans $S \leq 2$ m 1 <i>S</i> $\Delta hr \leq \Delta hr_{max}$ <i>S</i> in metres, valid for $S > 2$ m 4 max.	2,5 Valid for all spans $S \leq 2$ m 1,25 <i>S</i> $\Delta hr \leq \Delta hr_{max}$ <i>S</i> in metres, valid for $S > 2$ m 5 max.	3,2 Valid for all spans $S \leq 2$ m 1,6 <i>S</i> $\Delta hr \leq \Delta hr_{max}$ <i>S</i> in metres, valid for $S > 2$ m 6,3 max.	mm

Table 3 (continued)

Symbol	Description with respect to this table	Tolerance parameter				Unit		
		Class 1	Class 2	Class 3	Class 4			
<i>F</i>	Tolerance of parallelism of end stops or buffers on traversing track to right angles to longitudinal axis with parallelism symbol //			0,8 <i>S</i> ±8 max. <i>S</i> in metres	<i>S</i> ±10 max. <i>S</i> in metres	1,25 <i>S</i> ±12,5 max. <i>S</i> in metres	1,6 <i>S</i> ±16 max. <i>S</i> in metres	mm
<i>G</i> (see Note)	Tolerance of angularity related to crab rail cross-section at each point of traversing track with angularity symbol ∠			4	6	9	12	0/00
<i>K</i>	Tolerance of parallelism of crab rail related to web at each point of traversing track with parallelism symbol //			±0,5 <i>r</i> _{min}				mm
NOTE		Parameter <i>G</i> with the characteristic of datum applies to crab rails with flat upper rail surfaces only. For crab rails with convex surfaces, tolerances for <i>G</i> are not required.						

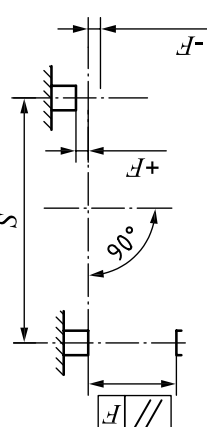
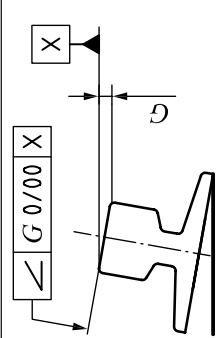
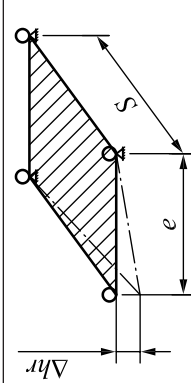
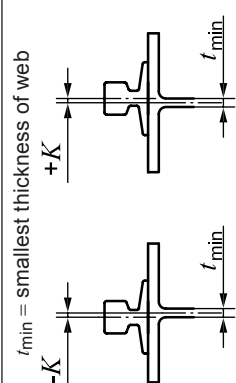
Table 4 — Construction tolerances for crane wheels of tolerance classes 1 to 4

Symbol	Description with respect to this table	Graphical representation	Tolerance parameter				Unit
			Class 1	Class 2	Class 3	Class 4	
A	Tolerance of span S of a crane related to wheel centre, wheel with flanges		± 2 Valid for all spans $S \leq 10$ m $\pm [2 + 0,1(S-10)]$ S in metres, valid for all spans $S > 10$ m	$\pm 2,5$ Valid for all spans $S \leq 10$ m $\pm [2,5 + 0,1(S-10)]$ S in metres, valid for all spans $S > 10$ m	$\pm 3,2$ Valid for all spans $S \leq 10$ m $\pm [3,2 + 0,1(S-10)]$ S in metres, valid for all spans $S > 10$ m	± 4 Valid for all spans $S \leq 10$ m $\pm [4 + 0,1(S-10)]$ S in metres, valid for all spans $S > 10$ m	mm
A	Tolerance of span S of a crane related to wheel centre, flangeless wheels, guide rollers on one side		$\pm 3,2$ Valid for all spans $S \leq 10$ m $\pm [3,2 + 0,1(S-10)]$ S in metres, valid for all spans $S > 10$ m	± 4 Valid for all spans $S \leq 10$ m $\pm [4 + 0,1(S-10)]$ S in metres, valid for all spans $S > 10$ m	± 5 Valid for all spans $S \leq 10$ m $\pm [5 + 0,1(S-10)]$ S in metres, valid for all spans $S > 10$ m	$\pm 6,3$ Valid for all spans $S \leq 10$ m $\pm [6,3 + 0,1(S-10)]$ S in metres, valid for all spans $S > 10$ m	mm
Δe	Tolerance of wheel base e or bogey distance e , 8 wheels		$\pm 3,2$ Valid for $e \leq 3$ m $\pm e$ e in metres, valid for $e > 3$ m	± 4 Valid for $e \leq 3$ m $\pm 1,25e$ e in metres, valid for $e > 3$ m	± 5 Valid for $e \leq 3$ m $\pm 1,6e$ e in metres, valid for $e > 3$ m	$\pm 6,3$ Valid for $e \leq 3$ m $\pm 2e$ e in metres, valid for $e > 3$ m	mm
ΔN	Parallel offset of crane wheels or bogeys, 8 wheels		± 5 Valid for independent drive only ± 2 Valid for coupled drive only, $S \leq 20$ m $\pm [2 + 0,2(S-20)]$ S in metres, valid for coupled drive only, $S > 20$ m	$\pm 6,3$ Valid for independent drive only $\pm 2,5$ Valid for coupled drive only, $S \leq 20$ m $\pm [2,5 + 0,2(S-20)]$ S in metres, valid for coupled drive only, $S > 20$ m	± 8 Valid for independent drive only $\pm 3,2$ Valid for coupled drive only, $S \leq 20$ m $\pm [3,2 + 0,2(S-20)]$ S in metres, valid for coupled drive only, $S > 20$ m	± 10 Valid for independent drive only ± 4 Valid for coupled drive only, $S \leq 20$ m $\pm [4 + 0,2(S-20)]$ S in metres, valid for coupled drive only, $S > 20$ m	mm

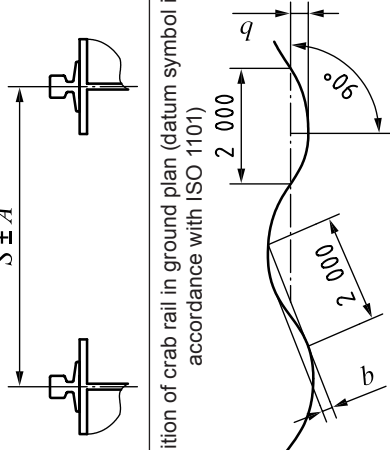
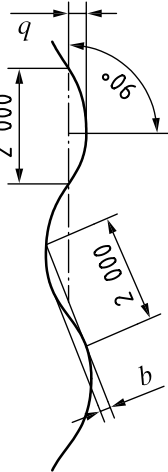
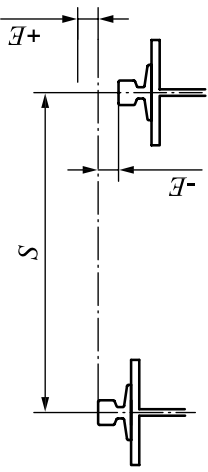
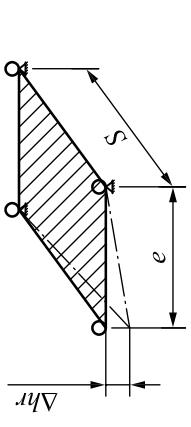
Table 4 (continued)

Symbol	Description with respect to this table	Tolerance parameter		Tolerance				Unit
		Graphical representation		Class 1	Class 2	Class 3	Class 4	
ΔF	Alignment tolerance of guide rollers or wheel flanges			$\pm 0,32a$ a in metres $\pm 0,4e$ e in metres	$\pm 0,4a$ a in metres $\pm 0,5e$ e in metres	$\pm 0,5a$ a in metres $\pm 0,63e$ e in metres	$\pm 0,63a$ a in metres $\pm 0,8e$ e in metres	mm
Δhr	Height tolerance of points of wheel contact For a given stiffness of structures related to wheel loads, the difference in height between the points of wheel contact shall be limited in such a way that the mean wheel load (crab with load in centre of bridge) of the driven wheels can change by no more than $\pm 5\%$. Where this calculation is not made, Δhr is valid for the height tolerance according to this table. The height tolerance of the points of wheel contact of a crane is the maximum vertical distance of a point of wheel contact from a plane S ; e set by three points of wheel contact. For statically determinate supported cranes, $\Delta hr = 0,4 S$ may be used.			2 max. Valid for all spans $S \leq 10$ m $[2 + 0,1(S-10)]$ max. S in metres, valid for all spans $S > 10$ m	2,5 max. Valid for all spans $S \leq 10$ m $[2,5 + 0,1(S-10)]$ max. S in metres, valid for all spans $S > 10$ m	3,2 max. Valid for all spans $S \leq 10$ m $[3,2 + 0,1(S-10)]$ max. S in metres, valid for all spans $S > 10$ m	4 max. Valid for all spans $S \leq 10$ m $[4 + 0,1(S-10)]$ max. S in metres, valid for all spans $S > 10$ m	mm

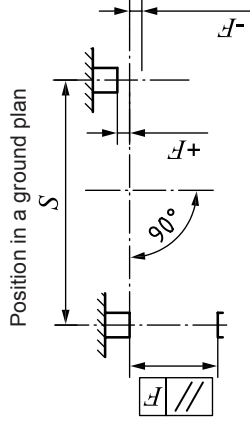
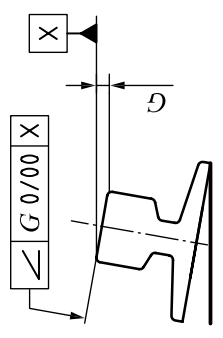
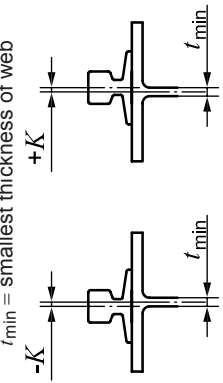
Table 4 (continued)

Symbol	Description with respect to this table	Tolerance parameter	Tolerance				Unit
			Class 1	Class 2	Class 3	Class 4	
ΔD	Diameter tolerance for coupled and independently driven crane wheels. a/S without wheel flanges e/S with wheel flanges	 <p style="text-align: center;">$\Delta D = D_1 - D_2$; $D = \frac{D_1 + D_2}{2}$; $D_1 > D_2$</p> <p>Where wheels are mechanically or electrically coupled, it is necessary to check whether the maximum allowable diameter difference requires higher values for e and a, or lower tolerances. For cranes with two coupled drives, ΔD shall be divided by 1,4.</p>	h9 For D_1 and D_2 . Diameter tolerance according to ISO 286-2 $\frac{1,6 a D}{S}$ D in metres $\frac{1,6 e D}{S}$ D in metres	h9 For D_1 and D_2 . Diameter tolerance according to ISO 286-2 $\frac{2 a D}{S}$ D in metres $\frac{2 e D}{S}$ D in metres	h9 For D_1 and D_2 . Diameter tolerance according to ISO 286-2 $\frac{2,5 a D}{S}$ D in metres $\frac{2,5 e D}{S}$ D in metres	h9 For D_1 and D_2 . Diameter tolerance according to ISO 286-2 $\frac{3,2 a D}{S}$ D in metres $\frac{3,2 e D}{S}$ D in metres	mm
φk	Axle parallelism tolerance in a ground plan (inclination of axis)		±0,3	±0,4	±0,5	±0,63	0/00
φr	Axle parallelism tolerance in a ground plan (inclination of wheel)		±0,4	±0,5	±0,63	±0,8	0/00
τk	Axle parallelism tolerance in elevation (axle camber) The tolerances are for an unloaded crane (without crab) with unrestricted support on or near the end carriages. The mean values of tolerances are chosen approximately so that under load (crab with total load in centre of bridge), a horizontal position of the wheel axle will result from elastic deformation.		+1,9 -0,4			+2,4 -0,5	0/00

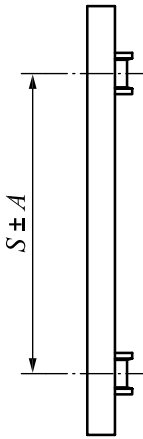
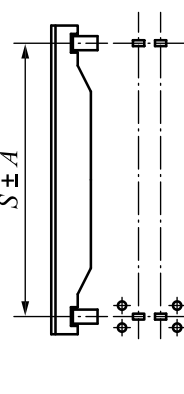
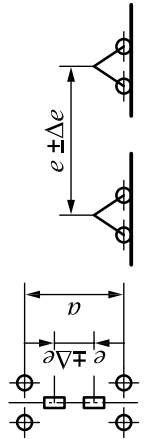
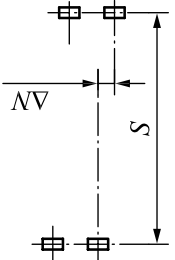
Table 4 (continued)

Symbol	Description with respect to this table	Tolerance parameter		Tolerance				Unit
		Graphical representation		Class 1	Class 2	Class 3	Class 4	
π'	Axle parallelism tolerance in elevation (wheel camber) The tolerances are for an unloaded crane (without crab) with unrestricted support on or near the end carriages. The mean values of tolerances are chosen approximately so that under load (crab with total load in centre of bridge), a horizontal position of the wheel axle will result from elastic deformation.			+2 -0,5		+2,6 -0,6		0/00
F	Tolerance of parallelism of end stops or buffers on crane at right angles to longitudinal axis with parallelism symbol //			$\pm(0,8S)$ S in metres ± 8 max.	$\pm(1,0S)$ S in metres ± 10 max.	$\pm(1,25S)$ S in metres $\pm 12,5$ max.	$\pm(1,6S)$ S in metres ± 16 max.	mm
αF	Axle parallelism tolerance of guide rollers across travelling track			$\pm 0,5$	$\pm 0,63$	$\pm 0,8$	± 1	0/00
βF	Axle parallelism tolerance of guide rollers along travelling track			$\pm 0,3$	$\pm 0,4$	$\pm 0,5$	$\pm 0,63$	0/00
Δh_F	Height tolerance of h_F			+0 -1	+0 -1,6	+0 -2,5	+0 -4	mm

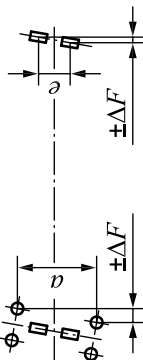
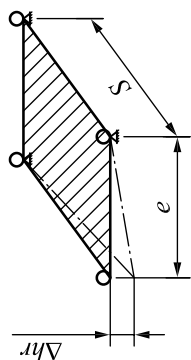
Table 5 — Construction tolerances for crab wheels of tolerance classes 1 to 4 and tolerance for the guide rollers in Table 4

Symbol	Description with respect to this table	Graphical representation	Tolerance parameter				Unit
			Class 1	Class 2	Class 3	Class 4	
A	Tolerance of span S of a crab related to wheel centre, wheel with flanges		± 1 Valid for all spans $S \leq 2$ m $\pm[1 + 0,1(S-2)]$ S in metres, valid for all spans $S > 2$ m	± 2 Valid for all spans $S \leq 2$ m $\pm[2 + 0,1(S-2)]$ S in metres, valid for all spans $S > 2$ m	$\pm 2,5$ Valid for all spans $S \leq 2$ m $\pm[2,5 + 0,1(S-2)]$ S in metres, valid for all spans $S > 2$ m	$\pm 3,2$ Valid for all spans $S \leq 2$ m $\pm[3,2 + 0,1(S-2)]$ S in metres, valid for all spans $S > 2$ m	mm
A	Tolerance of span S of a crab related to wheel centre, flangeless wheel, with guide rollers on one side		$\pm 1,6$ Valid for all spans $S \leq 2$ m $\pm[1,6 + 0,1(S-2)]$ S in metres, valid for all spans $S > 2$ m	$\pm 3,2$ Valid for all spans $S \leq 2$ m $\pm[3,2 + 0,1(S-2)]$ S in metres, valid for all spans $S > 2$ m	± 4 Valid for all spans $S \leq 2$ m $\pm[4 + 0,1(S-2)]$ S in metres, valid for all spans $S > 2$ m	± 5 Valid for all spans $S \leq 2$ m $\pm[5 + 0,1(S-2)]$ S in metres, valid for all spans $S > 2$ m	mm
Δe	Tolerance of wheel base e of crab wheels or bogey distance e , 8 wheels		$\pm 3,2$ e in metres, valid for $e \leq 3$ m $\pm e$ e in metres, valid for $e > 3$ m	± 4 e in metres, valid for $e \leq 3$ m $\pm 1,25e$ e in metres, valid for $e > 3$ m	± 5 e in metres, valid for $e \leq 3$ m $\pm 1,6e$ e in metres, valid for $e > 3$ m	$\pm 6,3$ e in metres, valid for $e \leq 3$ m $\pm 2e$ e in metres, valid for $e > 3$ m	mm
ΔN	Parallel offset of crab wheels or bogeys, 8 wheels		± 5 Valid for independent drive only ± 2 Valid for coupled drive only	$\pm 6,3$ Valid for independent drive only $\pm 2,5$ Valid for coupled drive only	± 8 Valid for independent drive only $\pm 3,2$ Valid for coupled drive only	± 10 Valid for independent drive only ± 4 Valid for coupled drive only	mm
ΔF	Alignment tolerance of guide rollers or wheel flanges		$\pm 0,32a$ a in metres $\pm 0,4e$ e in metres	$\pm 0,4a$ a in metres $\pm 0,5e$ e in metres	$\pm 0,5a$ a in metres $\pm 0,63e$ e in metres	$\pm 0,63a$ a in metres $\pm 0,8e$ e in metres	mm

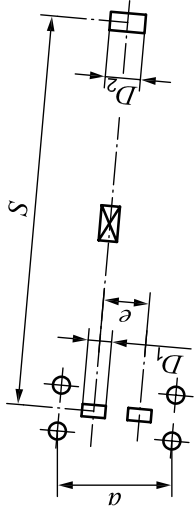
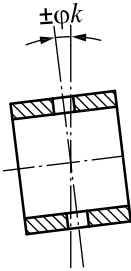
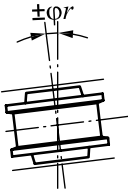
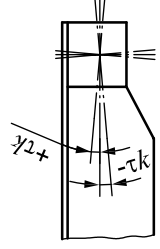
Table 5 (continued)

Symbol	Description with respect to this table	Tolerance parameter		Tolerance				Unit
		Graphical representation		Class 1	Class 2	Class 3	Class 4	
ΔD	Diameter tolerance for coupled and independently driven crab wheels			h9 Diameter tolerance according to ISO 286-2	h9 Diameter tolerance according to ISO 286-2	h9 Diameter tolerance according to ISO 286-2	h9 Diameter tolerance according to ISO 286-2	mm
Δhr	Height of tolerance of points of wheel contact			1,6 max. Valid for all spans $S \leq 2$ m [1,6 + 0,1(S-2)] max. S in metres, valid for all spans $S > 2$ m	2 max. Valid for all spans $S \leq 2$ m [2 + 0,1(S-2)] max. S in metres, valid for all spans $S > 2$ m	2,5 max. Valid for all spans $S \leq 2$ m [2,5 + 0,1(S-2)] max. S in metres, valid for all spans $S > 2$ m	3,2 max. Valid for all spans $S \leq 2$ m [3,2 + 0,1(S-2)] max. S in metres, valid for all spans $S > 2$ m	mm
ϕk	Axle parallelism tolerance in a ground plan of crab frame (inclination of axis)			±0,3	±0,4	±0,5	±0,63	0/00
ϕr	Axle parallelism tolerance in a ground plan of crab wheel (inclination of wheel)			±0,4	±0,5	±0,63	±0,8	0/00
τk	Axle parallelism tolerance in elevation of crab frame (axle camber)			+19 -0,4	+2,4 -0,5	—	—	0/00
τr	Axle parallelism tolerance in elevation of crab wheel (wheel camber)			+2 -0,5	+2,4 -0,5	—	+2,6 -0,6	0/00

Table 5 (continued)

Symbol	Description with respect to this table	Tolerance parameter	Tolerance				Unit
			Class 1	Class 2	Class 3	Class 4	
<i>F</i>	Tolerance of parallelism of end stops of buffers on crab at right angles to longitudinal axis with parallelism symbol //		$\pm 0,8S$ <i>S</i> in metres ± 8 max.	$\pm S$ <i>S</i> in metres ± 10 max.	$\pm 1,25S$ <i>S</i> in metres $\pm 12,6$ max.	$\pm 1,6S$ <i>S</i> in metres ± 16 max.	mm
NOTE For tolerances of guide rollers, see Table 4.							

Table 6 — Construction tolerances for rail joints

Tolerance parameter		Tolerance	
Symbol	Description	Graphical representation	All classes
H_F	Vertical offset of the welded joint at the rail flange		0 (for welding in production) 1 max. (for welding on site)
H_S	Horizontal offset of the rail head		1 max., with a taper of 1:50 to blend the offset
b_s	Inclination of rail in ground plan b_s and height c_h (lateral slope) with angularity symbol \sphericalangle	<p>Unevenness near joint welding shall be trued up at the rail head by grinding without notches</p> 	2
c_h	Tolerances b_s and c_h related to a test length of 1 m		2
H_X	Flatness after grinding the trued-up area of H_S No finishing required at the rail end joint near the rail fastening for a staggered rail end joint	—	0,5 max.

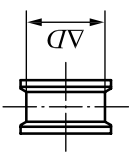
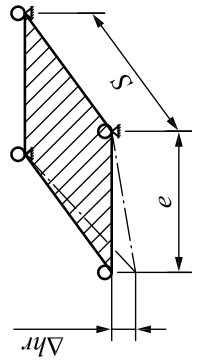
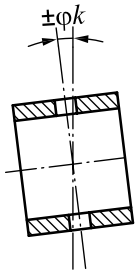
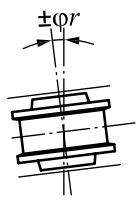
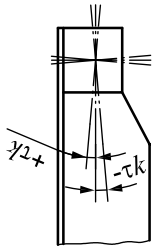
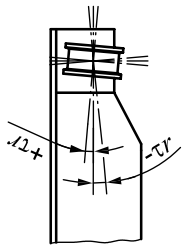
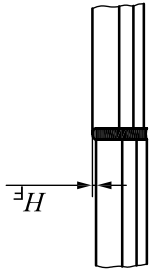
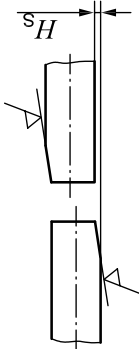
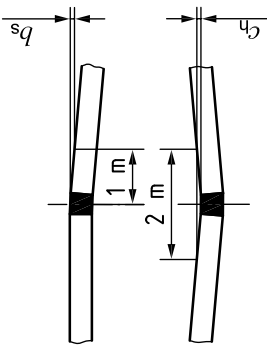
Detachable rail joints shall be in accordance with this table.

Table 7 — Operational tolerances for travel and traverse tracks and crane wheels of tolerances classes 1 to 4

Tolerance parameter		Tolerance					Unit
Symbol	Description with respect to this table	Graphical representation	Class 1	Class 2	Class 3	Class 4	Unit
A_{w1}	Tolerance of span S of crane rails related to rail centre at each point of travelling track	<p>$+A = S_{\max} - S$ $-A = S_{\min} - S$</p>	<p>± 10</p> <p>Valid for all spans $S \leq 16$ m</p> <p>$\pm[10 + 0,25(S-16)]$</p> <p>S in metres, valid for all spans $S > 16$ m</p>	<p>± 16</p> <p>Valid for all spans $S \leq 16$ m</p> <p>$\pm[16 + 0,25(S-16)]$</p> <p>S in metres, valid for all spans $S > 16$ m</p>	<p>± 25</p> <p>Valid for all spans $S \leq 16$ m</p> <p>$\pm[25 + 0,25(S-16)]$</p> <p>S in metres, valid for all spans $S > 16$ m</p>	<p>± 40</p> <p>Valid for all spans $S \leq 16$ m</p> <p>$\pm[40 + 0,25(S-16)]$</p> <p>S in metres, valid for all spans $S > 16$ m</p>	mm
B_{w1}	Tolerance of horizontal straightness of rail head at each point of travelling track	<p>Position of crane rail in ground plan</p>	<p>± 10</p>	<p>± 20</p>	<p>± 40</p>	<p>± 80</p>	mm
E_{w1}	Tolerance of height related to opposite measuring points at right angles at each point of travelling track	<p>Height of traversing track (lateral slope)</p>	<p>± 10</p>	<p>± 20</p>	<p>± 40</p>	<p>± 80</p>	mm
A_{w2}	Tolerance of span S of crab rails related to rail centre at each point of traversing track	<p>$S \pm A_{w2}$</p>	<p>± 6</p> <p>Valid for all spans $S \leq 16$ m</p>	<p>± 10</p> <p>Valid for all spans $S \leq 16$ m</p>	<p>± 16</p> <p>Valid for all spans $S \leq 16$ m</p>	<p>± 25</p> <p>Valid for all spans $S \leq 16$ m</p>	mm

Table 7 (continued)

Symbol	Description with respect to this table	Tolerance parameter				Unit
		Class 1	Class 2	Class 3	Class 4	
E_{w2}	Tolerance of height related to opposite measuring points at right angles at each point of traversing track	<p>Graphical representation</p> <p>Height of traversing track (lateral slope)</p>				mm
A_{w3}	Tolerance of span S of a crane related to wheel centre, wheel with flanges	± 5 Valid for $S \leq 10$ m $\pm [5+0,2(S-10)]$ S in metres, valid for $S > 10$ m	± 8 Valid for $S \leq 10$ m $\pm [8+0,2(S-10)]$ S in metres, valid for $S > 10$ m	$\pm 12,5$ Valid for $S \leq 10$ m $\pm [12,5+0,2(S-10)]$ S in metres, valid for $S > 10$ m	± 20 Valid for $S \leq 10$ m $\pm [20+0,2(S-10)]$ S in metres, valid for $S > 10$ m	mm
A_{w3}	Tolerance of span S of a crane related to wheel centre, with flangeless wheels and guide rollers on one side	$\pm 12,5$ Valid for $S \leq 10$ m $\pm [12,5+0,2(S-10)]$ S in metres, valid for $S > 10$ m	± 14 Valid for $S \leq 10$ m $\pm [14+0,2(S-10)]$ S in metres, valid for $S > 10$ m	± 16 Valid for $S \leq 10$ m $\pm [16+0,2(S-10)]$ S in metres, valid for $S > 10$ m	± 20 Valid for $S \leq 10$ m $\pm [20+0,2(S-10)]$ S in metres, valid for $S > 10$ m	mm
ΔD_{w3}	Tolerance on crane wheel diameter for independent drive	$h18$ Tolerances according to ISO 286-2	$h18$ Tolerances according to ISO 286-2	$h18$ Tolerances according to ISO 286-2	$h18$ Tolerances according to ISO 286-2	mm
ΔD_{w3}	Tolerance on crane wheel diameter for coupled drive	$IT12$ Tolerances according to ISO 286-2	$IT13$ Tolerances according to ISO 286-2	$IT14$ Tolerances according to ISO 286-2	$IT14$ Tolerances according to ISO 286-2	mm

Table 7 (continued)

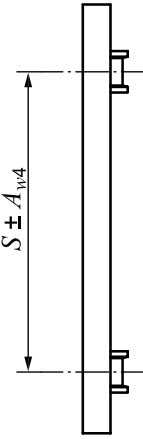
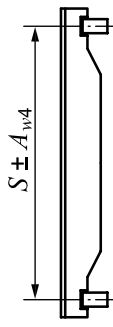
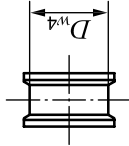
Tolerance parameter		Tolerance					Unit
Symbol	Description with respect to this table	Graphical representation	Class 1	Class 2	Class 3	Class 4	Unit
A_{w4}	Tolerance of span S of a crab related to wheel centre, wheel with flanges		±3 Valid for all spans $S \leq 2$ m $\pm[3 + 0,2(S-2)]$ S in metres, valid for $S > 2$ m	±6 Valid for all spans $S \leq 2$ m $\pm[6 + 0,2(S-2)]$ S in metres, valid for $S > 2$ m	±8 Valid for all spans $S \leq 2$ m $\pm[8 + 0,2(S-2)]$ S in metres, valid for $S > 2$ m	±12 Valid for all spans $S \leq 2$ m $\pm[12 + 0,2(S-2)]$ S in metres, valid for $S > 2$ m	mm
	Tolerance of span S of a crab related to wheel centre, with flangeless wheels and guide rollers on one side		±5 Valid for all spans $S \leq 2$ m $\pm[5 + 0,2(S-2)]$ S in metres, valid for $S > 2$ m	±10 Valid for all spans $S \leq 2$ m $\pm[10 + 0,2(S-2)]$ S in metres, valid for $S > 2$ m	±12 Valid for all spans $S \leq 2$ m $\pm[12 + 0,2(S-2)]$ S in metres, valid for $S > 2$ m	±16 Valid for all spans $S \leq 2$ m $\pm[16 + 0,2(S-2)]$ S in metres, valid for $S > 2$ m	mm
ΔD_{w4}	Tolerance of crab wheel diameter for independent drive		h18 Tolerances according to ISO 286-2	h18 Tolerances according to ISO 286-2	h18 Tolerances according to ISO 286-2	h18 Tolerances according to ISO 286-2	mm
	Tolerance of crab wheel diameter for coupled drive		IT12 Tolerances according to ISO 286-2	IT13 Tolerances according to ISO 286-2	IT14 Tolerances according to ISO 286-2	IT14 Tolerances according to ISO 286-2	mm

Bibliography

- [1] ISO 8686-1:1989, *Cranes — Design principles for loads and load combinations — Part 1: General*

British Standards Institution (BSI)

BSI is the national body responsible for preparing British Standards and other standards-related publications, information and services.

BSI is incorporated by Royal Charter. British Standards and other standardization products are published by BSI Standards Limited.

About us

We bring together business, industry, government, consumers, innovators and others to shape their combined experience and expertise into standards-based solutions.

The knowledge embodied in our standards has been carefully assembled in a dependable format and refined through our open consultation process. Organizations of all sizes and across all sectors choose standards to help them achieve their goals.

Information on standards

We can provide you with the knowledge that your organization needs to succeed. Find out more about British Standards by visiting our website at bsigroup.com/standards or contacting our Customer Services team or Knowledge Centre.

Buying standards

You can buy and download PDF versions of BSI publications, including British and adopted European and international standards, through our website at bsigroup.com/shop, where hard copies can also be purchased.

If you need international and foreign standards from other Standards Development Organizations, hard copies can be ordered from our Customer Services team.

Subscriptions

Our range of subscription services are designed to make using standards easier for you. For further information on our subscription products go to bsigroup.com/subscriptions.

With **British Standards Online (BSOL)** you'll have instant access to over 55,000 British and adopted European and international standards from your desktop. It's available 24/7 and is refreshed daily so you'll always be up to date.

You can keep in touch with standards developments and receive substantial discounts on the purchase price of standards, both in single copy and subscription format, by becoming a **BSI Subscribing Member**.

PLUS is an updating service exclusive to BSI Subscribing Members. You will automatically receive the latest hard copy of your standards when they're revised or replaced.

To find out more about becoming a BSI Subscribing Member and the benefits of membership, please visit bsigroup.com/shop.

With a **Multi-User Network Licence (MUNL)** you are able to host standards publications on your intranet. Licences can cover as few or as many users as you wish. With updates supplied as soon as they're available, you can be sure your documentation is current. For further information, email bsmusales@bsigroup.com.

BSI Group Headquarters

389 Chiswick High Road London W4 4AL UK

Revisions

Our British Standards and other publications are updated by amendment or revision.

We continually improve the quality of our products and services to benefit your business. If you find an inaccuracy or ambiguity within a British Standard or other BSI publication please inform the Knowledge Centre.

Copyright

All the data, software and documentation set out in all British Standards and other BSI publications are the property of and copyrighted by BSI, or some person or entity that owns copyright in the information used (such as the international standardization bodies) and has formally licensed such information to BSI for commercial publication and use. Except as permitted under the Copyright, Designs and Patents Act 1988 no extract may be reproduced, stored in a retrieval system or transmitted in any form or by any means – electronic, photocopying, recording or otherwise – without prior written permission from BSI. Details and advice can be obtained from the Copyright & Licensing Department.

Useful Contacts:

Customer Services

Tel: +44 845 086 9001

Email (orders): orders@bsigroup.com

Email (enquiries): cservices@bsigroup.com

Subscriptions

Tel: +44 845 086 9001

Email: subscriptions@bsigroup.com

Knowledge Centre

Tel: +44 20 8996 7004

Email: knowledgecentre@bsigroup.com

Copyright & Licensing

Tel: +44 20 8996 7070

Email: copyright@bsigroup.com



...making excellence a habit.™