



BSI Standards Publication

Aerospace — Screws, pan head, internal offset cruciform ribbed or unribbed drive, stepped shank, short or medium length MJ threads, metallic material, coated or uncoated, strength classes less than or equal to 1 100 MPa — Dimensions

National foreword

This British Standard is the UK implementation of ISO 12260:2016. It supersedes BS A 312:1997 which is withdrawn.

The UK participation in its preparation was entrusted to Technical Committee ACE/12, Aerospace fasteners and fastening systems.

A list of organizations represented on this committee can be obtained on request to its secretary.

This publication does not purport to include all the necessary provisions of a contract. Users are responsible for its correct application.

© The British Standards Institution 2016.
Published by BSI Standards Limited 2016

ISBN 978 0 580 86452 0

ICS 49.030.20

Compliance with a British Standard cannot confer immunity from legal obligations.

This British Standard was published under the authority of the Standards Policy and Strategy Committee on 31 March 2016.

Amendments/corrigenda issued since publication

Date	Text affected
------	---------------

**INTERNATIONAL
STANDARD****ISO
12260**Second edition
2016-02-15

**Aerospace — Screws, pan head,
internal offset cruciform ribbed
or unribbed drive, stepped shank,
short or medium length MJ threads,
metallic material, coated or uncoated,
strength classes less than or
equal to 1 100 MPa — Dimensions**

Aéronautique et espace — Vis à tête cylindrique, à empreinte cruciforme déportée, avec ou sans saillies antidérapantes, à fût dégagé et filetage MJ court ou de longueur moyenne, en matériau métallique, revêtues ou non revêtues, des classes de résistance inférieures ou égales à 1 100 MPa — Dimensions

Reference number
ISO 12260:2016(E)



COPYRIGHT PROTECTED DOCUMENT

© ISO 2016, Published in Switzerland

All rights reserved. Unless otherwise specified, no part of this publication may be reproduced or utilized otherwise in any form or by any means, electronic or mechanical, including photocopying, or posting on the internet or an intranet, without prior written permission. Permission can be requested from either ISO at the address below or ISO's member body in the country of the requester.

ISO copyright office
Ch. de Blandonnet 8 • CP 401
CH-1214 Vernier, Geneva, Switzerland
Tel. +41 22 749 01 11
Fax +41 22 749 09 47
copyright@iso.org
www.iso.org

Contents

Page

Foreword	iv
1 Scope	1
2 Normative references	1
3 Configuration and dimensions	1

Foreword

ISO (the International Organization for Standardization) is a worldwide federation of national standards bodies (ISO member bodies). The work of preparing International Standards is normally carried out through ISO technical committees. Each member body interested in a subject for which a technical committee has been established has the right to be represented on that committee. International organizations, governmental and non-governmental, in liaison with ISO, also take part in the work. ISO collaborates closely with the International Electrotechnical Commission (IEC) on all matters of electrotechnical standardization.

The procedures used to develop this document and those intended for its further maintenance are described in the ISO/IEC Directives, Part 1. In particular the different approval criteria needed for the different types of ISO documents should be noted. This document was drafted in accordance with the editorial rules of the ISO/IEC Directives, Part 2 (see www.iso.org/directives).

Attention is drawn to the possibility that some of the elements of this document may be the subject of patent rights. ISO shall not be held responsible for identifying any or all such patent rights. Details of any patent rights identified during the development of the document will be in the Introduction and/or on the ISO list of patent declarations received (see www.iso.org/patents).

Any trade name used in this document is information given for the convenience of users and does not constitute an endorsement.

For an explanation on the meaning of ISO specific terms and expressions related to conformity assessment, as well as information about ISO's adherence to the WTO principles in the Technical Barriers to Trade (TBT) see the following URL: [Foreword - Supplementary information](#)

The committee responsible for this document is ISO/TC 20, *Aircraft and space vehicles*, Subcommittee SC 4, *Aerospace fastener systems*.

This second edition cancels and replaces the first edition (ISO 12260:1996), of which it constitutes a minor revision.

Aerospace — Screws, pan head, internal offset cruciform ribbed or unribbed drive, stepped shank, short or medium length MJ threads, metallic material, coated or uncoated, strength classes less than or equal to 1 100 MPa — Dimensions

1 Scope

This International Standard specifies the dimensions of pan head screws with internal offset cruciform ribbed or unribbed drive, stepped shank, short or medium length MJ threads, in metallic material, coated or uncoated, with strength classes less than or equal to 1 100 MPa.

This International Standard is applicable to the compilation of aerospace product standards.

2 Normative references

The following documents, in whole or in part, are normatively referenced in this document and are indispensable for its application. For dated references, only the edition cited applies. For undated references, the latest edition of the referenced document (including any amendments) applies.

ISO 286-2, *Geometrical product specifications (GPS) — ISO code system for tolerances on linear sizes — Part 2: Tables of standard tolerance classes and limit deviations for holes and shafts*

ISO 3353 (all parts), *Aerospace — Lead and runout threads*

ISO 5855-2, *Aerospace — MJ threads — Part 2: Limit dimensions for bolts and nuts*

ISO 7913:1994, *Aerospace — Bolts and screws, metric — Tolerances of form and position*

ISO 14275, *Aerospace — Drives, internal, offset cruciform, ribbed — Metric series*

ISO 14276, *Aerospace — Drives, internal, offset cruciform — Metric series*

3 Configuration and dimensions

See [Figure 1](#) and [Table 1](#). Dimensions and tolerances are expressed in millimetres. They are applicable after any surface coating, but before the application of any lubricant.

Tolerances of form and position are specified in ISO 7913.

Break sharp edges 0,1 to 0,4

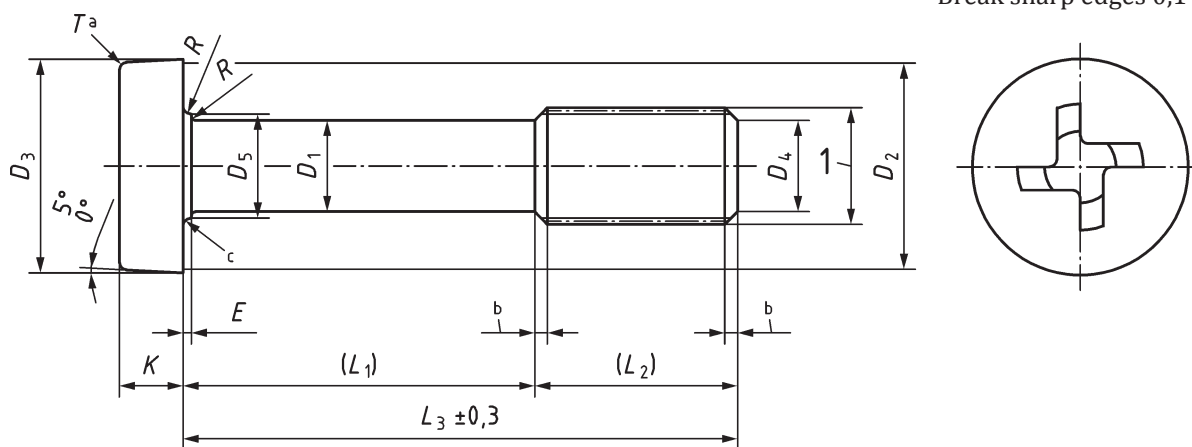

Key

- 1 thread
- a Shape optional.
- b In accordance with ISO 3353 (all parts).

Figure 1

Table 1

Diameter code	Thread ^a	D ₁	D ₂	D ₃	D ₄		D ₅	E	K		L ₁ ^c	L ₂ Thread		R		T		Drive code ^d	
		h12 ^b	min.	⁰ _{-0,3}	nom.	tol.	h12 ^b	^{+0,2} ₀	nom.	tol.	±0,2	short	medium	nom.	tol.	max.	min.		
040	MJ4×0,7 – 4h6h	3,0	6,7	8	3,0	⁰ _{-0,5}	4	0,4	2,4	⁰ _{-0,2}	2 to 40	7,5	10,0	0,4	⁰ _{-0,2}	1,6	0,4	R4	
050	MJ5×0,8 – 4h6h	3,9	8,7	10	3,4	±0,5	5	0,5	3,0	⁰ _{-0,2}	3 to 50	9,0	12,0	0,5	⁰ _{-0,2}	2,0	0,5	R5	
060	MJ6×1 – 4h6h	4,6	10,7	12	4,2		6	0,7	3,6	⁰ _{-0,3}	3 to 60	10,0	14,0	0,7		⁰ _{-0,2}	2,4	0,6	R6
070	MJ7×1 – 4h6h	5,6	12,7	14	5,2		7		4,2	4 to 70	11,0	15,0	0,8				⁰ _{-0,2}	2,8	
080	MJ8×1 – 4h6h	6,6	14,7	16	6,2		8	4,8	4 to 80	11,5	16,5	0,8		⁰ _{-0,2}		3,2		0,8	R8
100	MJ10×1,25 – 4h6h	8,3	18,7	20	7,9		10	0,8	6	⁰ _{-0,3}	5 to 100		14,5			20,5	0,8	⁰ _{-0,3}	4,0
120	MJ12×1,25 – 4h6h	10,3	22,7	24	9,8		12	0,9	7,2	⁰ _{-0,3}	6 to 120	16,0	22,5	0,9		4,8	1,2		R12

a In accordance with ISO 5855-2.

b See ISO 286-2.

c Increments:

1 for L₁ ≤ 30

2 for 30 < L₁ ≤ 100

4 for L₁ > 100

d In accordance with ISO 14275 or ISO 14276.

British Standards Institution (BSI)

BSI is the national body responsible for preparing British Standards and other standards-related publications, information and services.

BSI is incorporated by Royal Charter. British Standards and other standardization products are published by BSI Standards Limited.

About us

We bring together business, industry, government, consumers, innovators and others to shape their combined experience and expertise into standards-based solutions.

The knowledge embodied in our standards has been carefully assembled in a dependable format and refined through our open consultation process. Organizations of all sizes and across all sectors choose standards to help them achieve their goals.

Information on standards

We can provide you with the knowledge that your organization needs to succeed. Find out more about British Standards by visiting our website at bsigroup.com/standards or contacting our Customer Services team or Knowledge Centre.

Buying standards

You can buy and download PDF versions of BSI publications, including British and adopted European and international standards, through our website at bsigroup.com/shop, where hard copies can also be purchased.

If you need international and foreign standards from other Standards Development Organizations, hard copies can be ordered from our Customer Services team.

Subscriptions

Our range of subscription services are designed to make using standards easier for you. For further information on our subscription products go to bsigroup.com/subscriptions.

With **British Standards Online (BSOL)** you'll have instant access to over 55,000 British and adopted European and international standards from your desktop. It's available 24/7 and is refreshed daily so you'll always be up to date.

You can keep in touch with standards developments and receive substantial discounts on the purchase price of standards, both in single copy and subscription format, by becoming a **BSI Subscribing Member**.

PLUS is an updating service exclusive to BSI Subscribing Members. You will automatically receive the latest hard copy of your standards when they're revised or replaced.

To find out more about becoming a BSI Subscribing Member and the benefits of membership, please visit bsigroup.com/shop.

With a **Multi-User Network Licence (MUNL)** you are able to host standards publications on your intranet. Licences can cover as few or as many users as you wish. With updates supplied as soon as they're available, you can be sure your documentation is current. For further information, email bsmusales@bsigroup.com.

Revisions

Our British Standards and other publications are updated by amendment or revision.

We continually improve the quality of our products and services to benefit your business. If you find an inaccuracy or ambiguity within a British Standard or other BSI publication please inform the Knowledge Centre.

Copyright

All the data, software and documentation set out in all British Standards and other BSI publications are the property of and copyrighted by BSI, or some person or entity that owns copyright in the information used (such as the international standardization bodies) and has formally licensed such information to BSI for commercial publication and use. Except as permitted under the Copyright, Designs and Patents Act 1988 no extract may be reproduced, stored in a retrieval system or transmitted in any form or by any means – electronic, photocopying, recording or otherwise – without prior written permission from BSI. Details and advice can be obtained from the Copyright & Licensing Department.

Useful Contacts:

Customer Services

Tel: +44 845 086 9001

Email (orders): orders@bsigroup.com

Email (enquiries): cservices@bsigroup.com

Subscriptions

Tel: +44 845 086 9001

Email: subscriptions@bsigroup.com

Knowledge Centre

Tel: +44 20 8996 7004

Email: knowledgecentre@bsigroup.com

Copyright & Licensing

Tel: +44 20 8996 7070

Email: copyright@bsigroup.com

BSI Group Headquarters

389 Chiswick High Road London W4 4AL UK

