

BS ISO 12242:2012



BSI Standards Publication

Measurement of fluid flow in closed conduits — Ultrasonic transit-time meters for liquid

NO COPYING WITHOUT BSI PERMISSION EXCEPT AS PERMITTED BY COPYRIGHT LAW

raising standards worldwide™



National foreword

This British Standard is the UK implementation of ISO 12242:2012.

The UK participation in its preparation was entrusted to Technical Committee CPI/30/5, Velocity and Mass Methods.

A list of organizations represented on this committee can be obtained on request to its secretary.

This publication does not purport to include all the necessary provisions of a contract. Users are responsible for its correct application.

© The British Standards Institution 2012. Published by BSI Standards Limited 2012

ISBN 978 0 580 70392 8

ICS 17.120.10

Compliance with a British Standard cannot confer immunity from legal obligations.

This British Standard was published under the authority of the Standards Policy and Strategy Committee on 31 July 2012.

Amendments issued since publication

Date	Text affected
------	---------------

**Measurement of fluid flow in closed
conduits — Ultrasonic transit-time
meters for liquid**

*Mesurage de débit des fluides dans les conduites fermées —
Compteurs ultrasoniques pour liquides*





COPYRIGHT PROTECTED DOCUMENT

© ISO 2012

All rights reserved. Unless otherwise specified, no part of this publication may be reproduced or utilized in any form or by any means, electronic or mechanical, including photocopying and microfilm, without permission in writing from either ISO at the address below or ISO's member body in the country of the requester.

ISO copyright office
Case postale 56 • CH-1211 Geneva 20
Tel. + 41 22 749 01 11
Fax + 41 22 749 09 47
E-mail copyright@iso.org
Web www.iso.org

Published in Switzerland

Contents

Page

Foreword	v
Introduction	vi
1 Scope	1
2 Normative references	1
3 Terms and definitions	1
3.1 Quantities	1
3.2 Meter design	2
3.3 Thermodynamic conditions	3
3.4 Statistics	3
3.5 Calibration	5
3.6 Symbols and subscripts	5
3.7 Abbreviated terms	7
4 Principles of measurement	7
4.1 Description	7
4.2 Volume flow	9
4.3 Generic description	10
4.4 Time delay considerations	11
4.5 Refraction considerations	14
4.6 Reynolds number	15
4.7 Temperature and pressure correction	15
5 Performance requirements	15
6 Uncertainty in measurement	16
6.1 Introduction	16
6.2 Evaluation of the uncertainty components	16
7 Installation	18
7.1 General	18
7.2 Use of a prover	19
7.3 Calibration in a laboratory or use of a theoretical prediction procedure	19
7.4 Additional installation effects	21
8 Test and calibration	22
8.1 General	22
8.2 Individual testing — Use of a theoretical prediction procedure	22
8.3 Individual testing — Flow calibration under flowing conditions	23
9 Performance testing	24
9.1 Introduction	24
9.2 Repeatability and reproducibility	25
9.3 Additional test for meters with externally mounted transducers	25
9.4 Assessing the uncertainty of a meter whose performance is predicted using a theoretical prediction procedure	26
9.5 Fluid-mechanical installation conditions	26
9.6 Path failure simulation and exchange of components	27
10 Meter characteristics	27
10.1 Meter body, materials, and construction	27
10.2 Transducers	29
10.3 Electronics	29
10.4 Software	30
10.5 Exchange of components	31
10.6 Determination of density and temperature	31
11 Operational practice	32
11.1 General	32

11.2	Audit process	32
11.3	Operational diagnostics	34
11.4	Audit trail during operation; inter-comparison and inspection	36
11.5	Recalibration	37
Annex A	(normative) Temperature and pressure correction	42
Annex B	(informative) Effect of a change of roughness	48
Annex C	(informative) Example of uncertainty calculations	52
Annex D	(informative) Documents	65
Bibliography	67

Foreword

ISO (the International Organization for Standardization) is a worldwide federation of national standards bodies (ISO member bodies). The work of preparing International Standards is normally carried out through ISO technical committees. Each member body interested in a subject for which a technical committee has been established has the right to be represented on that committee. International organizations, governmental and non-governmental, in liaison with ISO, also take part in the work. ISO collaborates closely with the International Electrotechnical Commission (IEC) on all matters of electrotechnical standardization.

International Standards are drafted in accordance with the rules given in the ISO/IEC Directives, Part 2.

The main task of technical committees is to prepare International Standards. Draft International Standards adopted by the technical committees are circulated to the member bodies for voting. Publication as an International Standard requires approval by at least 75 % of the member bodies casting a vote.

Attention is drawn to the possibility that some of the elements of this document may be the subject of patent rights. ISO shall not be held responsible for identifying any or all such patent rights.

ISO 12242 was prepared by Technical Committee ISO/TC 30, *Measurement of fluid flow in closed conduits*, Subcommittee SC 5, *Velocity and mass methods*.

Introduction

Ultrasonic meters (USMs) have become one of the accepted flow measurement technologies for a wide range of liquid applications, including custody-transfer and allocation measurement. Ultrasonic technology has inherent features such as no pressure loss and wide rangeability.

USMs can deliver diagnostic information through which it may be possible to demonstrate that an ultrasonic liquid flowmeter is performing in accordance with specification. Owing to the extended diagnostic capabilities, this International Standard advocates the addition and use of automated diagnostics instead of labour-intensive quality checks. The use of automated diagnostics makes possible a condition-based maintenance system.

Measurement of fluid flow in closed conduits — Ultrasonic transit-time meters for liquid

1 Scope

This International Standard specifies requirements and recommendations for ultrasonic liquid flowmeters, which utilize the transit time of ultrasonic signals to measure the flow of single-phase homogenous liquids in closed conduits.

There are no limits on the minimum or maximum sizes of the meter.

This International Standard specifies performance, calibration and output characteristics of ultrasonic meters (USMs) for liquid flow measurement and deals with installation conditions. It covers installation with and without a dedicated proving (calibration) system. It covers both in-line and clamp-on transducers (used in configurations in which the beam is non-refracted and in those in which it is refracted). Included are both meters incorporating meter bodies and meters with field-mounted transducers.

2 Normative references

The following referenced documents are indispensable for the application of this document. For dated references, only the edition cited applies. For undated references, the latest edition of the referenced document (including any amendments) applies.

ISO 4006, *Measurement of fluid flow in closed conduits — Vocabulary and symbols*

3 Terms and definitions

For the purposes of this document, the terms and definitions given in ISO 4006 and the following apply.

3.1 Quantities

3.1.1 volume flowrate

$$q_V = \frac{dV}{dt}$$

where

V is volume;

t is time

NOTE Adapted from ISO 80000-4:2006,^[42] 4-30.

3.1.2 metering pressure

absolute fluid pressure in a meter under flowing conditions to which the indicated volume of liquid is related

3.1.3 mean velocity in the meter body

v
fluid flowrate divided by the cross-sectional area of the meter body

3.1.4
mean pipe velocity

v_p
fluid flowrate divided by the cross-sectional area of the upstream pipe

NOTE Where a meter has a reduced bore, the mean velocities in the upstream pipe and within the meter body itself differ.

3.1.5
path velocity

average fluid velocity on an ultrasonic path

3.1.6
Reynolds number

dimensionless parameter expressing the ratio between the inertia and viscous forces

3.1.7
pipe Reynolds number

Re_D
dimensionless parameter expressing the ratio between the inertia and viscous forces in the pipe

$$Re_D = \frac{\rho v_p D}{\mu} = \frac{v_p D}{\nu_{KV}}$$

where

- ρ is mass density;
- v_p is the mean pipe velocity;
- D is the pipe internal diameter;
- μ is the dynamic viscosity;
- ν_{KV} is the kinematic viscosity

NOTE Where a meter has a reduced bore, it is possible also to define the throat Reynolds number, in whose definition the mean velocity in the meter body, the meter internal diameter and the kinematic viscosity are used.

3.2 Meter design

3.2.1
meter body

pressure-containing structure of the meter

3.2.2
ultrasonic path

path travelled by an ultrasonic signal between a pair of ultrasonic transducers

3.2.3
axial path

path travelled by an ultrasonic signal either on or parallel to the axis of the pipe

3.2.4
diametrical path

ultrasonic path whereby the ultrasonic signal travels through the centre-line or long axis of the pipe

3.2.5
chordal path

ultrasonic path whereby the ultrasonic signal travels parallel to the diametrical path

3.2.6

field mounted

external to the pipe, attached on site, not prior to a laboratory calibration

3.3 Thermodynamic conditions

3.3.1

metering conditions

conditions, at the point of measurement, of the fluid of which the volume is to be measured

NOTE Also known as operating conditions or actual conditions.

3.3.2

standard conditions

defined temperature and pressure conditions used in the measurement of fluid quantity so that the standard volume is the volume that would be occupied by a quantity of fluid if it were at standard temperature and pressure

NOTE 1 Standard conditions may be defined by regulation or contract.

NOTE 2 Not preferred alternatives: reference conditions, base conditions, normal conditions, etc.

NOTE 3 Metering and standard conditions relate only to the volume of the liquid to be measured or indicated, and should not be confused with rated operating conditions or reference conditions (see ISO/IEC Guide 99:2007,^[44] 4.9 and 4.11), which refer to influence quantities (see ISO/IEC Guide 99:2007,^[44] 2.52).

3.3.3

specified conditions

conditions of the fluid at which performance specifications of the meter are given

3.4 Statistics

3.4.1

error

measured quantity value minus a reference quantity value

[ISO/IEC Guide 99:2007,^[44] 2.16]

3.4.2

repeatability (of results of measurements)

closeness of the agreement between the results of successive measurements of the same measurand carried out under the same conditions of measurement

NOTE 1 These conditions are called repeatability conditions.

NOTE 2 Repeatability conditions include:

- the same measurement procedure;
- the same observer;
- the same measuring instrument, used under the same conditions;
- the same location;
- repetition over a short period of time.

NOTE 3 Repeatability may be expressed quantitatively in terms of the dispersion characteristics of the results.

[ISO/IEC Guide 98-3:2008,^[43] B.2.15]

3.4.3

reproducibility (of results of measurements)

closeness of the agreement between the results of measurements of the same measurand carried out under changed conditions of measurement

NOTE 1 A valid statement of reproducibility requires specification of the conditions changed.

NOTE 2 The changed conditions may include:

- principle of measurement;
- method of measurement;
- observer;
- measuring instrument;
- reference standard;
- location;
- conditions of use;
- time.

NOTE 3 Reproducibility may be expressed quantitatively in terms of the dispersion characteristics of the results.

NOTE 4 Results are here usually understood to be corrected results.

[ISO/IEC Guide 98-3:2008,^[43] B.2.16]

3.4.4

resolution

smallest difference between indications of a meter that can be meaningfully distinguished

3.4.5

zero flow reading

flowmeter reading when the liquid is at rest, i.e. both axial and non-axial velocity components are essentially zero

3.4.6

linearization

way of reducing the non-linearity of an ultrasonic meter, by applying correction factors

NOTE The linearization can be applied in the electronics of the meter or in a flow computer connected to the USM. The correction can be, for example, piece-wise linearization or polynomial linearization.

3.4.7

uncertainty (of measurement)

parameter, associated with the result of a measurement, that characterizes the dispersion of the values that could reasonably be attributed to the measurand

NOTE 1 The parameter may be, for example, a standard deviation (or a given multiple of it), or the half-width of an interval having a stated level of confidence.

NOTE 2 Uncertainty of measurement comprises, in general, many components. Some of these components may be evaluated from the statistical distribution of the results of series of measurements and can be characterized by experimental standard deviations. The other components, which can also be characterized by standard deviations, are evaluated from assumed probability distributions based on experience or other information.

NOTE 3 It is understood that the result of the measurement is the best estimate of the value of the measurand, and that all components of uncertainty, including those arising from systematic effects, such as components associated with corrections and reference standards, contribute to the dispersion.

[ISO/IEC Guide 98-3:2008,^[43] B.2.18]

3.4.8
standard uncertainty

u

uncertainty of the result of a measurement expressed as a standard deviation

[ISO/IEC Guide 98-3:2008,^[43] 2.3.1]

3.4.9
expanded uncertainty

U

quantity defining an interval about the result of a measurement that may be expected to encompass a large fraction of the distribution of values that could reasonably be attributed to the measurand

[ISO/IEC Guide 98-3:2008,^[43] 2.3.5]

NOTE 1 The large fraction is normally 95 % and is generally associated with a coverage factor $k = 2$.

NOTE 2 The expanded uncertainty is often referred to as the uncertainty.

3.4.10
coverage factor

numerical factor used as a multiplier of the standard uncertainty in order to obtain an expanded uncertainty

NOTE Adapted from ISO/IEC Guide 98-3:2008,^[43] 2.3.6.

3.5 Calibration

3.5.1
flow calibration

calibration in which fluid flows through the meter

3.5.2
theoretical prediction procedure

procedure by which the performance of a meter is theoretically predicted, without liquid flowing through the meter

3.5.3
performance testing

testing of a representative sample of meters to determine, for example, reproducibility and installation requirements for meters geometrically similar to themselves

3.6 Symbols and subscripts

The symbols and subscripts used in this International Standard are given in Tables 1 and 2.

Table 1 — Symbols

Quantity	Symbol	Dimensions ^a	SI unit
Cross-sectional area of meter body	A	L^2	m^2
Speed of sound in fluid	c	LT^{-1}	m/s
Internal diameter of the meter body	d	L	m
Internal pipe diameter	D	L	m
Young's modulus	E	$ML^{-1}T^{-2}$	Pa
Function of path velocities	f	—	1
Integers (1,2,3, ...)	i,j,n	—	1
Calibration factor	K	—	1
Body end correction factor	K_E	—	1
Path-geometry factor	K_g	L^b or $LT^{-1} c$	m^b or m/s^c
Velocity profile correction factor	K_p	—	1
Body style correction factor	K_S	—	1
Minimum distance to a specified upstream flow disturbance	l_{min}	L	m
Path length	l_p	L	m
Absolute pressure	p	$ML^{-1}T^{-2}$	Pa
Volume flowrate	q_V	L^3T^{-1}	m^3/s
Internal pipe radius	r	L	m
External pipe radius	R	L	m
Throat Reynolds number	Re_d	—	1
Pipe Reynolds number	Re_D	—	1
Percentage maximum deviation in measured flowrate due to upstream fittings	S	—	1
Absolute temperature of the liquid	T	Θ	K
Transit time	t	T	s
Time delay	t_0	T	s
Mean axial fluid velocity in the meter body	v	LT^{-1}	m/s
Mean axial fluid velocity on ultrasonic path, i	v_i	LT^{-1}	m/s
Mean axial fluid velocity in the upstream pipe	v_p	LT^{-1}	m/s
Transducer axial separation	X	L	m
Thermal expansion coefficient	α	Θ^{-1}	K^{-1}
Pipe wall thickness	δ	L	m
Dynamic viscosity	μ	$ML^{-1}T^{-1}$	Pa s
Kinematic viscosity	ν_{kv}	L^2T^{-1}	m^2/s
Density of the liquid	ρ	ML^{-3}	kg/m^3
Poisson's ratio	σ	—	1
Angle between ultrasonic path and pipe axis	ϕ	—	rad

^a M ≡ mass; L ≡ length; T ≡ time ; Θ ≡ temperature.
^b Non-refracting configuration.
^c Refracting configuration.

Table 2 — Subscripts

Subscript	Meaning
cal	under calibration conditions
meas	measured (uncorrected)
op	under operational conditions
true	actual (corrected)

3.7 Abbreviated terms

AGC	automatic gain control
FAT	factory acceptance test
MSOS	measured speed of sound
SNR	signal to noise ratio
SOS	speed of sound
RSOS	reference speed of sound
USM	ultrasonic meter
USMP	USM package, including meter tubes, flow conditioner, flow computer and thermowell

4 Principles of measurement

4.1 Description

The ultrasonic transit-time flowmeter is a sampling device that measures discrete path velocities using one or more pairs of transducers. Each pair of transducers is located a known distance, l_p , apart such that one is upstream of the other (see Figure 1). The upstream and downstream transducers send and receive pulses of ultrasound alternately, referred to as contra-propagating transmission, and the times of arrival are used in the calculation of average axial velocity, v . At any given instant, the difference between the apparent speed of sound in a moving liquid and the speed of sound in that same liquid at rest is directly proportional to the instantaneous velocity of the liquid. As a consequence, a measure of the average axial velocity of the liquid along a path can be obtained by transmitting an ultrasonic signal along the path in both directions and subsequently measuring the transit time difference.

The volume flowrate of a liquid flowing in a completely filled closed conduit is defined as the average velocity of the liquid over a cross-section multiplied by the area of the cross-section. Thus, by measuring the average velocity of a liquid along one or more ultrasonic paths (i.e. lines, not the area) and combining the measurements with knowledge of the cross-sectional area and the velocity profile over the cross-section, it is possible to obtain an estimate of the volume flowrate of the liquid in the conduit.

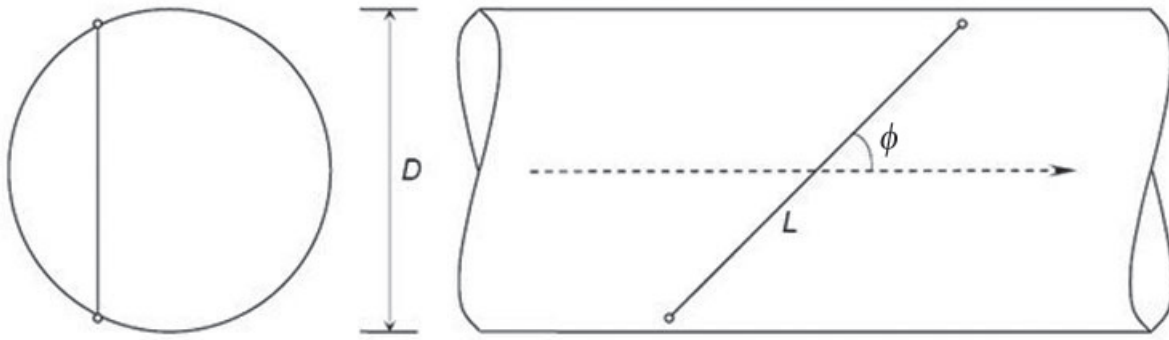

Figure 1 — Measurement principle

Several techniques can be used to obtain a measure of the average effective speed of propagation of an ultrasonic signal in a moving liquid in order to determine the average axial flow velocity along an ultrasonic path line. However, the normal technique applied in modern USMs is the direct time differential technique.

The basis of this technique is the measurement of the transit time of ultrasonic signals as they propagate between a transmitter and a receiver. The velocity of propagation of the ultrasonic signal is the sum of the speed of sound, c , and the flow velocity in the direction of propagation. Therefore the transit time upstream and downstream can be expressed as:

$$t_{fl_up/dn} \approx \int_{l=0}^{l_p} \frac{1}{c + v_l \cdot n} \cdot dl \quad (1)$$

where

- c is the speed of sound in the fluid;
- n is the unit normal vector to the wave front;
- v_l is the flow velocity vector at location, l , on the path l_p .

NOTE This is correct whether the transmitter is upstream or downstream.

With the assumptions that the flow velocity is in the axial direction only and that $v_i \ll c$, where v_i is the mean axial flow velocity on ultrasonic path line i , then the upstream and downstream transit times can be written as

$$t_{fl_up} = \frac{l_p}{c - v_i \cos \phi} \quad (2)$$

$$t_{fl_dn} = \frac{l_p}{c + v_i \cos \phi} \quad (3)$$

Rearranging terms and solving for v_i gives

$$\frac{1}{t_{fl_dn}} - \frac{1}{t_{fl_up}} = \frac{t_{fl_up} - t_{fl_dn}}{t_{fl_up} t_{fl_dn}} = \frac{2v_i \cos \phi}{l_p} \quad (4)$$

$$v_i = \frac{l_p}{2 \cos \phi} \frac{\Delta t}{t_{fl_up} t_{fl_dn}} \quad (5)$$

where

l_p is the distance between the transducers;

Δt is the difference in transit times;

ϕ is the angle of inclination of the ultrasonic signal with respect to the axial direction of the flow.

The speed of sound can be calculated as follows:

$$\frac{1}{t_{fl_dn}} + \frac{1}{t_{fl_up}} = \frac{t_{fl_up} + t_{fl_dn}}{t_{fl_up} t_{fl_dn}} = \frac{2c}{l_p} \quad (6)$$

$$c = \frac{l_p (t_{fl_up} + t_{fl_dn})}{2 t_{fl_up} t_{fl_dn}} \quad (7)$$

4.2 Volume flow

The individual path velocity measurements are combined by a mathematical function to yield an estimate of the mean velocity in the meter body:

$$v = f(v_1, \dots, v_n) \quad (8)$$

where n is the total number of paths.

Owing to variations in path configuration and different proprietary approaches of solving Formula (8), even for a given number of paths, the exact form of $f(v_1, \dots, v_n)$ can vary.

The relationship between the mean pipe velocity and the measured path velocities depends on the flow profile. In fully developed flow, the flow profile depends only on the Reynolds number and the pipe roughness.

One possible solution is to calculate the mean velocity as a weighted sum of the path velocities and to apply a velocity profile factor, K_p , to compensate for profile changes. The value of K_p is calculated by an algorithm that takes into account flow regime (laminar, transitional, and turbulent), as well as other process variables, as required.

$$v = K_p \sum_{i=1}^n w_i v_i \quad (9)$$

The volume flowrate, q_V , is given by:

$$q_V = Av \quad (10)$$

where

v is the estimate of the mean pipe velocity;

A is the cross-sectional area of the measurement section.

Note that increasing n may reduce the uncertainty associated with flow profile variations.

4.3 Generic description

4.3.1 General

This sub-clause is a generic description of USMs for liquids. It recognizes the scope for variation within commercial designs and the potential for new developments. For the purpose of description, USMs are considered to consist of several components, namely:

- a) transducers;
- b) meter body with ultrasonic path configuration;
- c) electronic data processing and presentation unit.

NOTE In a meter with externally mounted transducers, the meter body is the pipe to which the transducers are fixed.

4.3.2 Transducers

Transducers are the transmitters and receivers of the ultrasonic signal. They can be supplied in various forms. Typically they comprise a piezoelectric element with electrode connections and a supporting mechanical structure with which the process connection is made.

Typical arrangements are shown in Figures 2 and 3. To measure the axial velocity, the transducer transmits ultrasonic waves at a non-perpendicular angle to the meter body axis in the direction of a second transducer or reflection point in the meter body interior. There are two methods of mounting the transducers:

- a) external to the pressure-retaining boundary;
- b) internal to the pressure-retaining boundary.

The beam of the USM may be

- 1) refracted;
- 2) non-refracted.

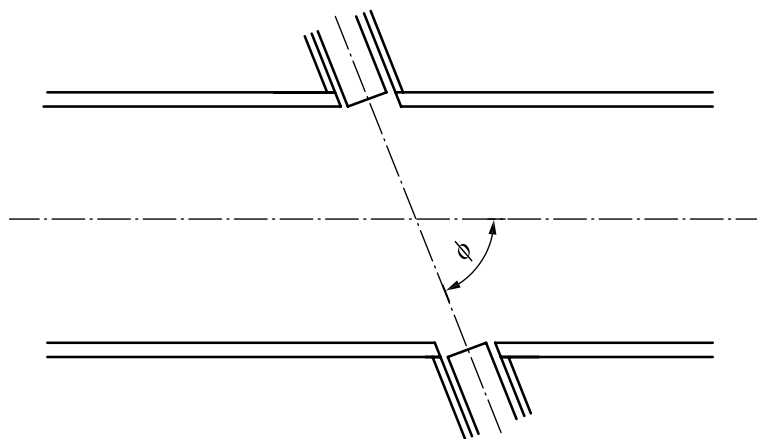

Figure 2 — Non-refracted configuration

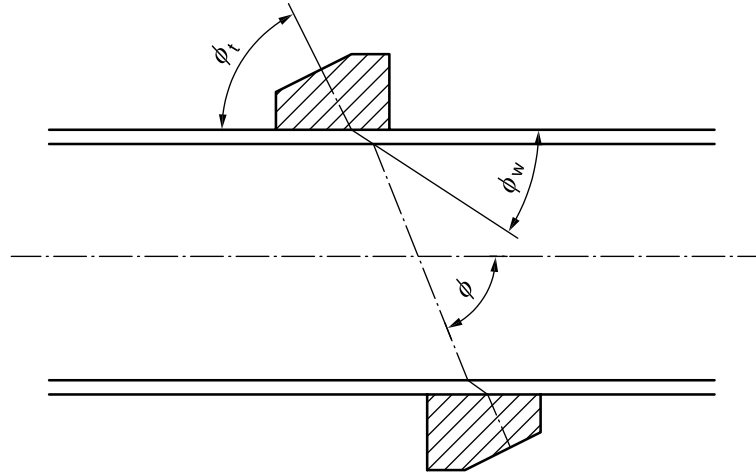

Figure 3 — Refracted configuration with an external mount

If the transducers are external to the pipe wall boundary, then the beam is always refracted; this configuration is typically referred to as clamp-on or field mounted. The geometry of a refracted beam is a function of, among other things, the liquid sound velocity (and thus temperature). The beam geometry determines the optimal transducer position. If the transducers are not placed at their optimal position, the measurement uncertainty increases.

If the transducers are internal to the pipe wall boundary, this configuration is typically referred to as in-line; the beam is almost always non-refracted.

4.3.3 Meter body and ultrasonic path configurations

The meter body is essentially a pipe to which the transducers are attached. Temperature and pressure have an effect on the pipe area (see 4.7 and Annex A). In a reduced-bore meter, the area of the measurement section is smaller than that of the pipe.

USMs are available in a variety of path configurations. The numbers of measurement paths are generally chosen based on a requirement with respect to variations in velocity distribution and required accuracy.

As well as variations in the radial position of the measurement paths in the cross-section, the path configuration can be varied in orientation to the pipe axis. By utilizing reflection of the ultrasonic wave from the interior of the meter body or from a fabricated reflector, the path can traverse the cross-section several times.

Some ultrasonic path types are illustrated in Figures 4 and 5. Figure 4 shows examples of single-path meters, Figure 5 examples of multipath meters.

Velocity measurements made on multiple paths are typically less susceptible to changes in flow profile than those made on a single path. Double traverses in a single plane are much less sensitive to non-axial velocity components than single traverse paths. Other configurations, e.g. the triple traverse mid-radius path, may be sensitive to non-axial components but can be used in combination to eliminate or to reduce the effects of swirl and cross-flow. Direct paths can be single, double or crossed.

4.3.4 Time measurement

All USMs contain an electronic part that generates and receives signals and performs time measurement.

4.4 Time delay considerations

In 4.1 it is assumed that the ultrasonic signal spends all of the transit time in the fluid and that the direction of propagation is at an angle, ϕ , to the pipe wall. In a real system, the measured time between the ultrasonic signal

leaving the transmitter and being received at the receiver includes a time delay, t_0 , due to intervening materials, electronics, signal processing, cable lengths, etc.:

$$t_{me_up/dn} = t_{fl_up/dn} + t_0 \quad (11)$$

Here it is assumed that the difference between the delay times t_{0_up} and t_{0_dn} is small compared with the transit times $t_{me_up/dn}$. Any difference between t_{0_up} and t_{0_dn} results in a zero offset.

Formulae (5) and (7) then take the form

$$v_i = \frac{l_p}{2 \cos \phi} \frac{\Delta t}{(t_{me_up} - t_0)(t_{me_dn} - t_0)} \quad (12)$$

$$c = \frac{l_p}{2} \frac{(t_{me_up} + t_{me_dn} - 2t_0)}{(t_{me_up} - t_0)(t_{me_dn} - t_0)} \quad (13)$$

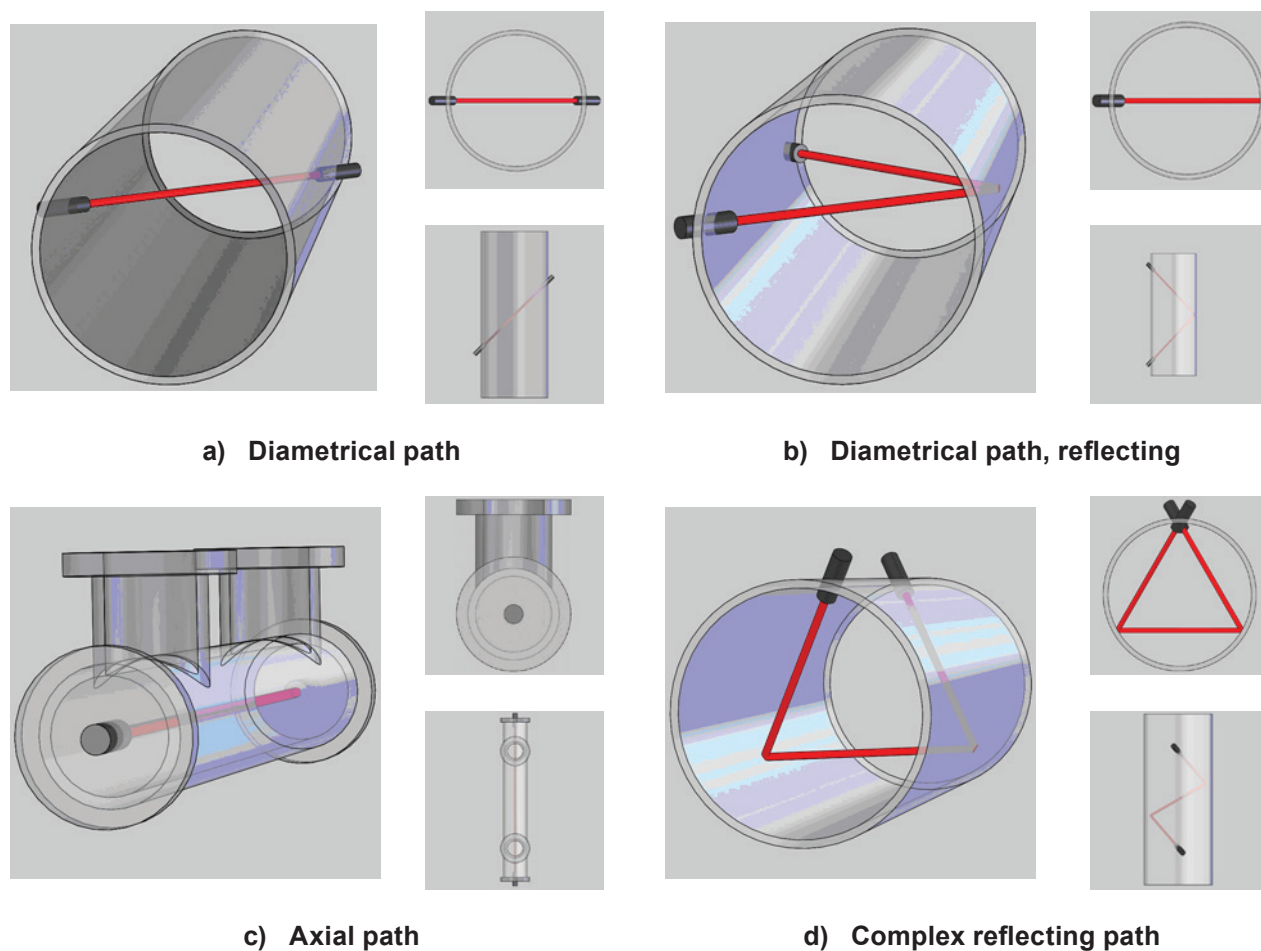

Figure 4 — Some Ultrasonic path types for single-path meters

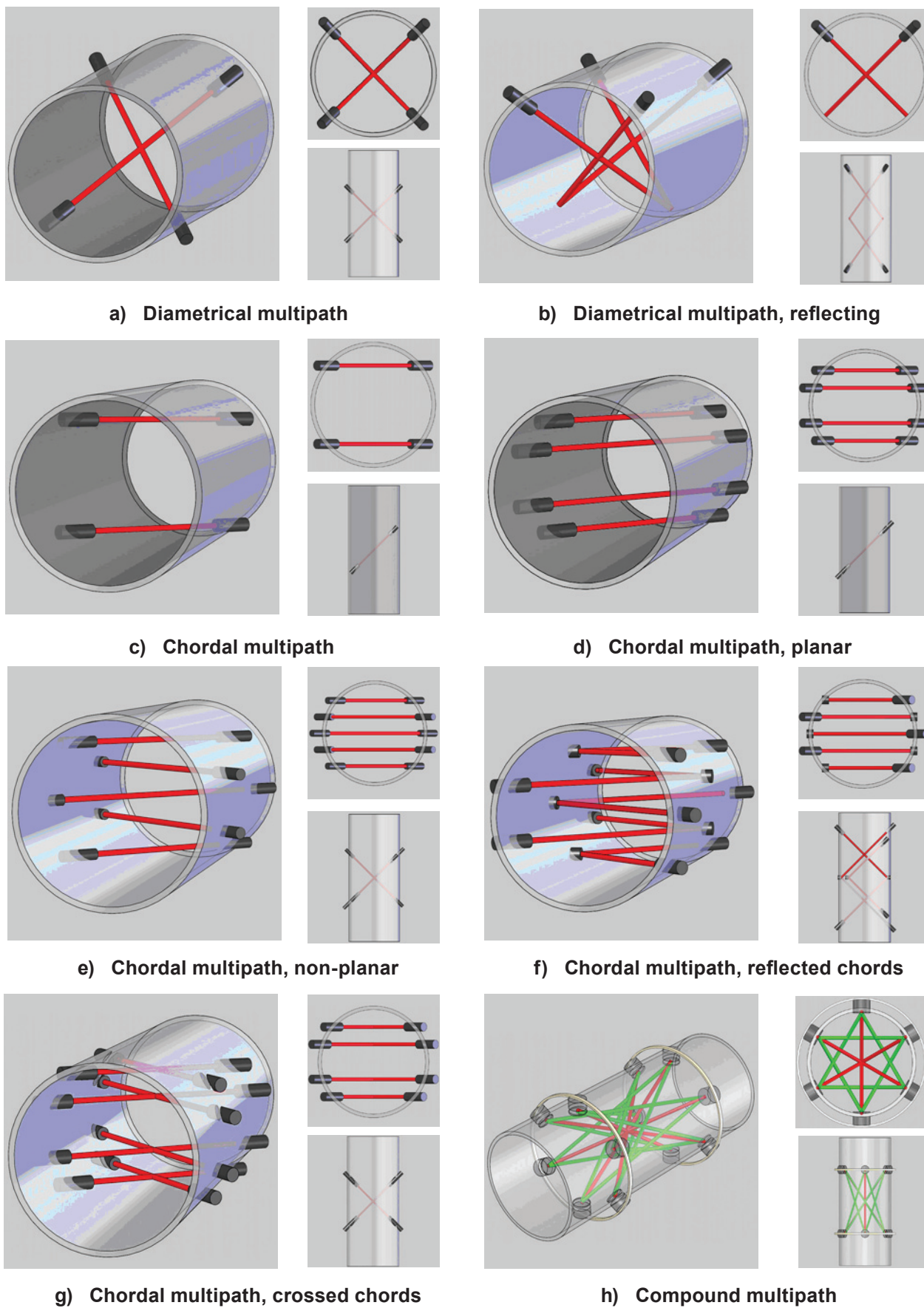

Figure 5 — Some ultrasonic path types for multipath meters

4.5 Refraction considerations

It is necessary for USMs that utilize externally mounted transducer arrangements (see Figure 3) to compensate for refraction in order to operate properly and accurately. When a sound wave passes through an interface between two materials at oblique angles and the materials have different acoustic impedances, both reflected and refracted waves are produced. Sound-wave refraction takes place as the sound passes from the transducer into the pipe wall, from the pipe wall into pipe lining (if present), and from the pipe or pipe lining into the liquid. This is due to the different velocities of the acoustic waves within these materials. With externally mounted transducer arrangements, Formula (5) is usually rearranged into a different form, which is derived in this subclause.

With the definition of the angles according to Figure 3, Snell's law can be expressed as Formula (14):

$$\frac{\cos \phi_t}{c_t} = \frac{\cos \phi_w}{c_w} = \frac{\cos \phi}{c} \quad (14)$$

where

c_t is the speed of sound in the transducer's coupling wedge;

c_w is the speed of sound in the wall;

c is the speed of sound in the liquid.

As a consequence, ϕ and l_p in Formulae (5) and (12) become functions of the speeds of sound, c_t , c_w , and c and hence in general, of the temperature, pressure, and composition of the process fluid and intervening materials.

Using the assumption (already made in 4.1) that the velocity is much smaller than the speed of sound in the fluid, the product of the transit times in the fluid measured upstream and downstream approximately equals the square of the transit time t_{fl} in the fluid with no flow:

$$t_{fl_up} t_{fl_dn} = \left(t_{fl} + \frac{\Delta t}{2} \right) \left(t_{fl} - \frac{\Delta t}{2} \right) = t_{fl}^2 - \frac{\Delta t^2}{4} \approx t_{fl}^2 \quad (15)$$

Formula (5) becomes:

$$v_i = \frac{l_p}{2 \cos \phi} \frac{\Delta t}{t_{fl}^2} \quad (16)$$

The speed of sound in the fluid can be substituted for the path length and the transit time in the fluid. Then from Formula (14) the speed of sound and angle in the coupling wedge are substituted for the speed of sound and angle in the fluid:

$$v_i = \frac{l_p}{\cos \phi} \frac{\Delta t}{t_{fl} 2 t_{fl}} = \frac{c}{\cos \phi} \frac{\Delta t}{2 t_{fl}} = \frac{c_t}{\cos \phi_t} \frac{\Delta t}{2 t_{fl}} \quad (17)$$

The sum of the transit times in the fluid measured upstream and downstream equals twice the transit time in the fluid:

$$v_i = \frac{c_t}{\cos \phi_t} \frac{\Delta t}{t_{fl_up} + t_{fl_dn}} \quad (18)$$

Just as in 4.4 the transit times t_{fl_up} and t_{fl_dn} in the fluid are replaced by the measured transit times t_{me_up} , t_{me_dn} , and the delay time t_0 :

$$v_i = \frac{c_t}{\cos \phi_t} \frac{\Delta t}{(t_{me_up} + t_{me_dn} - 2t_0)} \quad (19)$$

Thus the measured flow velocity is not directly dependent on the speed of sound in the fluid.

4.6 Reynolds number

The pipe Reynolds number is given by:

$$Re_D = \frac{v_p D \rho}{\mu} \quad (20)$$

where

- D is the internal diameter of the pipe;
- v_p is the mean axial liquid velocity in the pipe;
- ρ is the actual density;
- μ is the dynamic viscosity.

The effect of the Reynolds number on the uncertainty of a USM is discussed in 6.2.3.

4.7 Temperature and pressure correction

During flow calibration, the meter flow calibration factor is determined and applied. Any subsequent change in pressure or temperature from that encountered during the flow calibration alters the physical dimensions of the meter and, if not corrected for, introduces a systematic flow measurement error. In general, the temperature and pressure during calibration are different from those encountered under operating conditions. Temperature and pressure correction is not always necessary for process applications. For many instruments, the influence of pressure and temperature is typically negligible compared with the total uncertainty. For high accuracy applications (e.g. custody transfer) and extreme temperatures or pressures, this may no longer be the case.

In A.1 to A.4, a simple approach is given to allow an initial estimate to be made of the flow error caused by temperature and pressure conditions that differ from the calibration reference condition. If this error is significant relative to the uncertainty required for custody transfer or allocation purposes, a more detailed assessment of flow error has to be performed as described in A.5. ISO 17089-1:2010,^[41] Annex E provides an extensive and detailed explanation of the process and readers are advised to consult that document for the background to many of the statements made in Annex A.

5 Performance requirements

The selection of the USM depends on its required performance. There are many different applications. The performance is normally specified in terms of uncertainty in measured volume flowrate over a working range of Reynolds number (or flowrate). For control purposes, any value of uncertainty may be specified. For custody-transfer measurement, users usually refer to the performance criteria described in relevant application standards, such as those of the International Organization for Standardization (ISO), the Organisation Internationale de Métrologie Légale (OIML), the American Petroleum Institute (API) *Manual of petroleum measurement standards*, or others where uncertainty, repeatability and linearity are specified.

The uncertainty is derived in Clause 6 using the equations derived in Clause 4. Clause 7 covers installation effects (on both the calibration and the use of the USM). Clause 8 describes calibration. Clause 9 covers the components of uncertainty that need only be evaluated once for a design of USM. Clause 11 covers how to deliver the performance in Clause 5 through the audit trail, and how to maintain it through the use of diagnostics and recalibration in the field (using a prover) and in the laboratory. Clause 10 covers meter characteristics, especially in terms of design, manufacture and markings.

6 Uncertainty in measurement

6.1 Introduction

Following ISO/IEC Guide 98-3:2008,^[43] this analysis is based on the mathematical relationship between the measured volume flow and all input quantities on which it depends. The standard uncertainty of each input quantity is evaluated and the combined uncertainty is derived by propagation of uncertainty.

The volume flow measured by a USM is given by Formulae (9) and (10). When the meter is calibrated, a calibration factor K is included. Thus the volume flow is:

$$q_V = KK_p A \sum_{i=1}^n w_i v_i \quad (21)$$

So the uncertainty depends on

- a) the uncertainty $u(K)$ in the calibration factor K ;
- b) the uncertainty $u(K_p)$ in K_p due to the velocity profile;
- c) the uncertainty $u(A)$ in the area of the measurement cross-section;
- d) the uncertainty $u(v)$ due to the path-velocity measurement.

The evaluation of $u(v)$ is based on Formula (12) or Formula (19), as appropriate. The first factor on the right hand side of Formula (12) and Formula (19) can be referred to as the path geometry factor, K_g . It determines what transit time difference is caused by a certain path velocity and transit time. The dimensions of K_g depend on whether Formula (12) or Formula (19) is used. The total uncertainty in the measurement of the path velocity thus includes the following three components:

- 1) the uncertainty $u(K_g)$ in the path geometry factor;
- 2) the uncertainty $u(t)$ in the time measurement;
- 3) the uncertainty $u(t_0)$ in the delay time compensation.

If temperature and pressure influences have to be considered, the appropriate expressions need to be included in Formulae (12) and (21). The uncertainties of the temperature and pressure measurement are added as additional uncertainty components.

The standard uncertainty of the flow measurement is derived from the components by propagation of uncertainty. The level of confidence of the standard uncertainty is 68 %, assuming a normal distribution (see ISO/IEC Guide 98-3:2008,^[43] 4.3.6). A coverage factor can be applied to report an expanded uncertainty with a higher level of confidence; usually the coverage factor is $k = 2$, resulting in a level of confidence of approximately 95 % (see ISO/IEC Guide 98-3:2008,^[43] 6.3.3).

Examples of uncertainty calculations are given in Annex C.

6.2 Evaluation of the uncertainty components

6.2.1 Introduction

The evaluation of the uncertainty components depends, among other things, on how the meter is calibrated.

Calibration methods are

- a) theoretical prediction procedure only;
- b) flow calibration in a laboratory (no *in situ* use of a prover or a master meter);

- c) *in situ* calibration, at certain time intervals, against a master meter which is itself calibrated in a flow laboratory at certain time intervals;
- d) *in situ* calibration against a prover, at certain time intervals;
- e) *in situ* calibration, at certain time intervals, against a master meter which is itself calibrated against a prover at certain time intervals.

When the meter is calibrated, a calibration factor derived from the calibration result removes some of the sources of error. Thus, the uncertainties of all input quantities that are assumed to be constant are removed and replaced by the uncertainty in the calibration factor which is identical to the uncertainty of the calibration. This may apply to uncertainties $u(A)$, $u(K_g)$, and $u(t_0)$ when a meter is flow calibrated on the same meter body to be installed in the field. A field calibration by means of a prover also reduces the contribution of uncertainty in $u(K_p)$ that is caused by flow profile disturbances.

One way of evaluating the uncertainty of an input quantity is performance testing. This applies, for example, to the flow-profile uncertainty caused by perturbations and to the path geometry factor with externally mounted transducers.

It is possible that some input quantities that are considered constant at calibration do not stay constant after the meter is installed in the field. An evaluation of the long-term uncertainty, therefore, requires all components to be considered.

The evaluation of the individual uncertainty components is described in 6.2.2 to 6.2.7.

NOTE See also 7.4.2, 7.4.3, 7.4.4, and 7.4.1. Damage increases the uncertainty.

6.2.2 Uncertainty $u(K)$ in the calibration factor (see Clause 8)

After the meter has been calibrated, the uncertainty of the calibration factor K is identical to the uncertainty of the calibration.

If a meter is not flow-calibrated, but its performance is predicted by a theoretical prediction procedure, the uncertainty as measured under 9.3 and 9.4 is regarded as an uncertainty in K_g .

For calibration in the field, see 11.5.3.2.

6.2.3 Uncertainty $u(K_p)$ in velocity profile (see Clause 7)

In the case of a fully developed turbulent flow, the effect of velocity profile on K_p can be estimated using the pipe Reynolds number and the roughness of the pipe wall (see Annex B).

In the Reynolds number range between approximately 2 000 and 10 000, the flow changes from laminar to turbulent conditions. In the region between laminar and turbulent conditions, transitional flow occurs, and the velocity profile switches rapidly back and forth between shapes that are approximately equal to laminar and turbulent profiles. In the process of switching back and forth, more complex velocity profiles also occur. The Reynolds number at which transitional flow occurs and the exact nature of the transitional flow is dependent on numerous factors, including the pipe geometry and the prevailing thermal conditions. The range of 2 000 to 10 000 is given as a general guide to the maximum and minimum limits for transitional flow, but within that range, transition normally occupies a narrower range of Reynolds number.

The impact of transitional flow on the measurement uncertainty depends on the meter design. Meters employing only diameter paths are very sensitive to the transition from laminar to turbulent flow, and for these meters the value of K_p changes from 0,75 for laminar flow to more than 0,9 in turbulent flow. Therefore if K_p is incorrectly applied because of uncertainty regarding a critical Reynolds number, large errors could be incurred. Multipath meters that employ additional paths that are not on the diameter can reduce these effects and may also be able to evaluate the shape of the profile and therefore detect whether the flow is laminar, transitional or turbulent.

If the USM requires a manual input to characterize the flowing liquid condition and to determine K_p , e.g. liquid density and viscosity, the actual values for the density and the dynamic viscosity shall be entered in the USM computer during calibration as well as during operation; moreover, the sensitivity of the USM to these parameters shall be calculated so that the user can determine the need to change these parameters

as operating conditions change. Viscosity may also be calculated based on temperature and/or ultrasonic measurements.

In the field, the flow profile can be disturbed because of perturbations. The value of $u(K_p)$ then depends on the character and magnitude of the disturbance and on the sensitivity of the meter to it. The sensitivity of the meter to flow profile disturbances can be reduced by using multiple paths. The magnitude of the disturbance can be reduced by a flow conditioner. Flow conditioning can also have an impact on the effects of transition.

Distortion of the flow profile can occur in both laminar and turbulent conditions. In addition, thermal gradients can occur in laminar flows, see 6.2.5.

The uncertainty due to flow profile disturbances can be estimated by performance testing (see Clause 9) with typical perturbations [upstream fittings (bends, etc.) and upstream steps]. The performance testing evaluates the minimum length of upstream straight pipe required for the specific meter design to achieve a specified $u(K_p)$.

See 7.3.2, 7.3.3, 7.3.6, 7.4.2, 7.4.3, 8.3.2.4, 9.5, and 11.5.3.2.

6.2.4 Uncertainty $u(A)$ in the cross-sectional area of the measurement section

If the meter is not flow-calibrated, it is necessary for the uncertainty of the cross-sectional area of the measurement section to be derived from the uncertainty of the geometrical measurements. This mainly concerns meters shipped without a meter body. The inner pipe diameter is calculated from the measured outer pipe diameter and the wall thickness. Ovality may be significant.

The area of the measurement section is also affected by temperature and pressure (see 4.7 and Annex A).

6.2.5 Uncertainty $u(K_g)$ in the path geometry factor

With meters shipped without a meter body, the meter factor is derived by means that depend on the specific meter design. The uncertainty related to this process can be evaluated by performance-testing. See 9.3.

Temperature has an effect on externally mounted meters because of refraction [see, for example, c_t in Formula (19)] and needs to be considered.

When operating in the laminar flow regime, significant thermal gradients can form in the fluid, as turbulent mixing is absent. The resulting sound velocity gradient along the ultrasonic path causes refraction and a departure from the assumptions used in calculating the path geometry factor. Therefore errors can occur in laminar flows when there are differences between the fluid and ambient or pipe wall temperatures.

6.2.6 Uncertainty $u(t)$ in the time measurement

There is uncertainty in the time measurement due to resolution, zero stability, noise and turbulence. See 8.2.2 and 11.4.2.2.

6.2.7 Uncertainty $u(t_0)$ in the delay time compensation

The time delay, t_0 , is due to intervening materials, electronics, signal-processing, cable lengths, etc. The speed of sound of the intervening materials depends on temperature. The magnitude of this effect can be calculated and compensated for, if it is not negligible.

7 Installation

7.1 General

The requirements for installation of process meters may be substantially different from the requirements for custody transfer meters. The purpose of this clause is to enable the user to consider the uncertainties introduced by the installation and, if possible, to reduce them. This clause applies to calibration (Clause 8) as well as to operation (Clause 11).

In terms of installation effects there are two options:

- a) use of a prover in the field;
- b) calibration in a laboratory.

The items in 7.4 shall be considered for both options.

7.2 Use of a prover

If a prover (or a master meter calibrated *in situ* against a prover) is used to calibrate the USM, then the effects of upstream bends are compensated for by the calibration. Changes in flowrate or viscosity may have an effect. Upstream flow conditions that change after the use of the prover (e.g. a filter or flow conditioner becoming partially blocked or opening different parallel meter tubes in a header) may also have an effect.

7.3 Calibration in a laboratory or use of a theoretical prediction procedure

7.3.1 General

If the USM is calibrated in a laboratory, then the effect of any difference between the installation at calibration and that on site shall be considered (see Clause 9).

If the performance of the USM is predicted using a theoretical prediction procedure, then the effect of any difference between the installation used for the tests in 9.4 and the installation on site shall be considered.

If a master meter is calibrated in a laboratory and used to calibrate the USM, then the effects of installation on the master meter (rather than the USM) shall be considered.

7.3.2 Upstream and downstream straight pipe length requirements

Various combinations of upstream fittings, valves, bends, and lengths of straight pipe can produce velocity profile distortions at the meter inlet that may result in flowrate measurement errors. The magnitude of the meter error depends on the type and severity of the flow distortion and on the sensitivity of the meter design to this distortion. This error may be reduced by increasing the length of upstream straight pipes or by using flow conditioners. Alternatively, carrying out flow calibrations *in situ* or under conditions similar to metering conditions compensates for this error. Research work on installation effects is ongoing; so the installation-designer should consult the USM manufacturer to review the latest test results and evaluate how a specific USM design may be affected by the upstream piping configuration of the planned installation. In order to achieve the desired meter performance, it may be necessary for the installation designer to alter the original piping configuration or to include a flow conditioner as part of the meter run.

Typical upstream piping conditions (operating conditions) like bends, headers, T-joints, flow conditioners, filtration equipment, diameter changes (steps, expanders, reducers), and valves introduce swirl, an asymmetric flow profile, a flat flow profile, a peaked flow profile or combinations of these. A length of straight pipe upstream of the USM or USMP can reduce these effects.

The minimum length of straight upstream pipe, l_{\min} , between an upstream fitting and the USM is the minimum length such that for that length and for all longer lengths the calibration factor of the USM is within a specified value S % of the value in a long straight pipe. The value of S is small where the overall uncertainty is low. The value of l_{\min} is different for different upstream piping configurations, and can only be determined using a set of reference standards. Determination of l_{\min} for a standard set of upstream piping configurations is a major task during performance testing; see Clause 9. The manufacturer shall supply l_{\min} for each perturbation defined in 9.5 for at least one value of S . Determination of l_{\min} of an upstream piping configuration for which l_{\min} is not yet known is the responsibility of the user.

The recommended minimum length of straight downstream pipe is $3D$.

The important difference in 7.1 is the difference between the performance in the field and that at calibration. If the meter is used with l_{\min} upstream, but the calibration is not undertaken in a sufficiently long straight pipe, the

error could be greater than S . If too short a distance to perturbations is unavoidable, the uncertainty caused by this can be reduced by using the same pipe layout at calibration as in the field.

Owing to the large variety of USM types, upstream piping configurations, and flow conditioners, it is practically impossible to standardize upstream lengths. Furthermore USM technology is improving, which makes standardization with regard to this point even more difficult.

7.3.3 Protrusions and diameter steps

Changes in internal diameters and protrusions should be avoided at the USM inlet to avoid the disturbance of the velocity profile.

The flanges, and adjacent upstream pipe, shall be straight and cylindrical, and all have the same inside diameter as the internal diameter of the inlet of the meter, preferably within 1 % but at maximum within 3 %, and be carefully aligned to minimize flow disturbances, especially at the upstream flange. The effect of having an upstream pipe smaller in diameter than the meter is much larger than that of having an upstream pipe larger than the meter.

For a minimum upstream length of $2D$, there shall be no flow disturbances from flanges, flow straighteners, etc. Over a length of at least $10D$ or l_{\min} upstream of the meter, whichever is smaller, the pipe section(s) shall fulfil the following requirements.

- a) The diameter step (the difference between the diameters) shall not exceed 3 % of D . Moreover, the actual step caused by misalignment and/or change in diameter shall not exceed 3 % of D at any point of the internal circumference of the pipe.
- b) The internal weld of the downstream flange of the upstream piping shall be ground smooth and no part of the upstream gasket or flange face edge shall protrude into the flow stream.
- c) The pipe is said to be cylindrical when no diameter in any plane differs by more than 3 % from the average internal diameter D obtained from the measurements specified.

The value for the pipe diameter D shall be the mean of the internal diameters over a length of $0,5D$ upstream of the USM. The internal mean diameter can be determined by various methods, which shall be supported by an adequate quality-control system. The instruments shall be traceable to internationally recognized standards.

When determining the pipe diameter D by hand-held instruments, this diameter shall be the arithmetic mean of measurements of at least 12 diameters, namely four diameters positioned at approximately equal angles to each other, distributed in each of at least three cross-sections evenly distributed over a length of $0,5D$, two of these sections being at distance 0 and $0,5D$ from the USM and one being in the plane of the weld.

Diameter steps larger than 3 % within $10D$ upstream of the meter are allowed only in exceptional cases. In these cases, the manufacturer of the USM is required to prove that the additional bias due to the diameter steps is sufficiently small, e.g. within performance testing, see Clause 9.

7.3.4 Thermowells

See 10.6.2.

7.3.5 Flow conditioners

One of the main advantages of USMs is the absence of a pressure drop. The use of a flow conditioner introduces a pressure drop and negates this advantage. Lack of available space for sufficient upstream length or unquantifiable effects of upstream pipework configuration are the most common reasons for its use.

Installing a flow conditioner at any position in the meter run upstream of the USM causes a change in the flowrate indicated by the meter. This change depends on many factors (e.g. flow conditioner type, meter type, position relative to the USM, flow perturbation upstream of the flow conditioner). In some cases, the change is negligible. To avoid this additional uncertainty, the best option is that the USM is calibrated with the actual flow conditioner and meter tube as one package (USMP). Alternatively, a flow conditioner may be installed in accordance with 9.5.

Tube bundles and vane-type flow conditioners only suppress swirl; perforated-plate type conditioners both remove swirl and improve the flow profile, but cause more pressure loss than a tube bundle or a vane.

7.3.6 Wall roughness

The upstream pipework used during calibration should be similar in roughness to that used *in situ*. If the actual pipework is used for calibration, then there is no additional requirement.

If the roughness of the upstream pipework *in situ* is different from that used at calibration, there is an effect on the flow profile. The effect of a roughness change is dependent on the meter design and can be estimated (see Annex B).

If the roughness changes in service owing to dirt, wax, sand, rusting or a defective inner coating, this may cause error (see also 11.4.2.3).

In addition to affecting the profile, the internal roughness of the meter body can also cause significant scattering of the ultrasonic signal; this particularly affects externally mounted meters. In many cases, it does not cause a measurement error, but can cause the meter to fail to read. Rougher pipework, owing to the reduction in signal strength, also limits the wall reflections that can be used. Pipe wall roughness can also affect the estimation of the pipe internal diameter from pipe outside diameter and wall thickness measurements.

7.4 Additional installation effects

7.4.1 Non-steady flow

Pulsations and non-steady flow beyond the manufacturer's specifications shall be avoided.

7.4.2 Contamination by particles, a second liquid or gas

Deposits which can be present in liquid pipelines (e.g. scale, wax, dirt or sand) may affect the accuracy of a meter by reducing its cross-sectional area and by reducing the effective ultrasonic path length and/or changing the effective path angle. They may also change the surface roughness: see 7.3.6.

This International Standard covers measurement of single phase homogeneous liquids. To ensure that this is so, filtration of the flow upstream may be desirable, and in bi-directional applications, filtration both upstream and downstream may be desirable. The potential for flow profile disturbance caused by filtration equipment should, however, be recognized. Accumulation of deposits should be avoided.

If gas is present in the stream beyond manufacturer-specified limits, an eliminator should be provided to remove it.

Water in oil beyond manufacturer-specified limits should be avoided.

Cavitation should be avoided.

7.4.3 Vibration

USMs shall not be exposed to vibration levels or vibration frequencies that might excite the natural frequencies of electronic system boards, components or ultrasonic transducers. Vibration levels shall not exceed those specified by the manufacturer.

7.4.4 Electrical noise

Even though a USM design has been tested to withstand electrical noise influences, the USM or its connected wiring shall not be exposed to any unnecessary electrical noise, including alternating current, solenoid transients or radio transmissions, especially at ultrasonic frequencies.

7.4.5 Insulation

Under normal circumstances, it is not necessary to insulate the meter body or adjoining pipework. However, in some limited circumstances, such as cryogenic or laminar flow applications, insulating the meter and pipework may be necessary to avoid incurring additional uncertainty.

In low Reynolds number applications, where the flow may be in laminar or transitional regimes, insulation may be effective in preventing the formation of thermal gradients, which can result in additional uncertainty in the path geometry factor (see 6.2.5). In order for insulation to be effective in laminar and transitional flows, insulation should be applied from a point upstream, where the flow is well mixed, up to and including the meter itself and the straight pipe immediately downstream of the meter.

7.4.6 Acoustic couplant

Where an acoustic couplant is used, it is advisable that the user check the acoustic couplant conditions in order to avoid ultrasonic signal attenuation due to loss or degradation of the acoustic couplant.

8 Test and calibration

8.1 General

The requirements for calibration of process meters may be substantially different from the requirements for custody transfer meters. The user shall determine which tests recommended in Clause 8 are necessary for their applications (see Clause 5).

If the claimed uncertainty of the USM is less than or equal to 1 %, calibration in accordance with 8.3 is required.

8.2 Individual testing — Use of a theoretical prediction procedure

8.2.1 Geometrical parameters

The manufacturer shall document (where available):

- a) the average internal diameter of the meter;
- b) the cross-sectional area of the meter;
- c) the length of each ultrasonic path between transducer faces;
- d) the inclination angle of each ultrasonic path or the axial (meter body axis) distance between transducer pairs;
- e) the uncertainty of these measurements;
- f) the meter body material;
- g) the meter body pressure and temperature expansion coefficients;
- h) the wall thickness;
- i) the wall roughness.

The meter body temperature shall be measured at the time these measurements are made.

All instruments used to perform these measurements shall have valid calibrations traceable to internationally recognized standards.

8.2.2 Timing and time delays, and zero flow verification test

The time delays shall be measured and a zero flow verification test carried out.

8.3 Individual testing — Flow calibration under flowing conditions

8.3.1 General

Both individual USMs and USM-packages (USMPs) (as described in 10.1.4) may be calibrated.

The flow calibration delivers a set of systematic errors, as a function of the Reynolds number (or actual flowrate), which can be used to correct the meter output. This set is usually presented as a calibration curve.

Differences in dimensions due to temperature and pressure differences between calibration and operation may be corrected as described in 4.7.

8.3.2 Laboratory flow calibration

8.3.2.1 General

To minimize the uncertainty of the calibration, the calibration shall be conducted:

- a) according to good laboratory practice;
- b) in accordance with methods recognized by International Standards;
- c) at a laboratory operating in accordance with ISO/IEC 17025;^[40]
- d) under good flow conditions (see 8.3.2.4);
- e) under steady flow conditions (see 8.3.2.4);
- f) over a statistically significant duration of time (see 8.3.2.2);
- g) over the appropriate range of Reynolds numbers to describe the in-service response of the meter. A sufficient number of points to characterize the meter accurately should be taken;
- h) where possible, at a similar viscosity to meter operating conditions. This ensures that not only Reynolds number but also flowrate are matched. If a wide range of viscosity is encountered in the field, then calibration at more than one viscosity may be required, so that the whole Reynolds number range is covered;
- i) where possible, the upstream and downstream pipe sections of the meter should be used for both the initial calibration and recalibrations. Where this is not practical, calibration spools that duplicate the upstream and downstream pipe sections (including flow conditioners if used) should be used. For the initial calibration, there are advantages and disadvantages in using the duplicate spools rather than the actual spools: using the actual spools is better for the initial calibration, but if duplicate spools are to be used for subsequent calibrations, they should perhaps be used for the initial calibration so that any change in the meter may be seen. Requirements for alignment of the upstream pipework (whether the actual spools or duplicate spools) of the meter may be important;
- j) the upstream meter installation shall be fully described;
- k) where possible, at a similar temperature and pressure to meter operating conditions. Where not possible, refer to 4.7 and Annex A.

8.3.2.2 Duration of the calibration

The duration of a measurement (one single flowrate) shall be large enough to render insignificant the effects of random variations within the meter processes due to turbulence in the flow. It shall also be large enough to allow inaccuracy due to response times of the meter processes introduced by changes in flowrate and conditions prior to and after the test to be insignificant. As with any flowmeter calibration, the duration shall be large enough to reduce the uncertainty introduced by the meter output resolution to insignificant levels.

8.3.2.3 Uncertainty of the calibration facility

The uncertainty of measurements performed at the test facility shall be sufficiently low to enable the overall metering system uncertainty budget to be met. The reference measurement system shall have an uncertainty smaller by a factor of at least three than the system under test, whenever possible.

8.3.2.4 Flow conditions

The upstream piping conditions in the laboratory shall be chosen so that minimal additional errors (consistent with the performance claimed in Clause 5) are introduced.

The upstream straight length of the meter package shall be greater than or equal to l_{\min} . If the minimum length is used, then it is necessary to include the uncertainty of the installation effect at the calibration in the overall uncertainty, in addition to the uncertainty of the installation effect *in situ*. The requirements and recommendations given in 7.3 have to be taken into account. The conditions during the calibration or test at the calibration facility, e.g. pipe internal diameters, upstream pipe configurations, and condition of the inner surfaces of the USM and the pipes, shall be accurately documented.

Perforated plates generate significant turbulence. Calibration immediately downstream of a perforated plate affects the short-term repeatability of a USM when the perforated plate is close to the meter, typically less than $10D$ away.

Calibration using a flying-start-and-finish technique has advantages over a static-start-and-finish technique, because the flow velocity is constant throughout the collection of calibration data.

8.3.2.5 Limited calibration range at initial calibration

It is recognized that it may not be possible to test large USMs up to their maximum flowrate, because of the limitations of currently available test facilities. The USM is acceptable over the range of Reynolds numbers over which it has been calibrated.

If dependence of the calibration factor on the Reynolds number has been established for the USM, it is acceptable to use a liquid of lower viscosity for the calibration than the liquid to be found in the field.

If it is desired to use a USM at Reynolds numbers above those available in liquid calibration laboratories (e.g. in very hot water or in cryogenic liquids), it may be necessary to extrapolate. Extrapolation has risks, results in additional uncertainty, and is only acceptable if the algorithms are a good representation of the physics. Additional uncertainty shall be estimated.

8.3.2.6 Bi-directional calibration

A flow calibration is only valid for the direction in which the meter is calibrated. A valid flow calibration for a bi-directional application requires calibration of the meter in each direction.

8.3.2.7 Report

Results of calibration shall be available with the meter, together with a statement of conditions under which the calibration took place.

9 Performance testing

9.1 Introduction

Performance testing is carried out to assess those uncertainty components that need be determined only once for a particular type of USM, so that individual meters do not need to be tested. The results of the performance testing shall be incorporated in a detailed report that is available to the user.

This clause defines methods for assessing uncertainty components that are not eliminated by calibration, in order that the uncertainty of the meter in the field may be evaluated. These methods are intended for

use by manufacturers to determine the performance of their products and by users or independent testing establishments to verify the manufacturer's specifications.

Performance testing shall be conducted by a laboratory operating in accordance with ISO/IEC 17025^[40] or equivalent.

The meters used for performance testing shall be equipped with all their characteristic parts (electronics, transducers, software, etc.) The validity of the performance test shall be clearly defined. It is recommended that the performance testing be carried out on one of the smaller meter sizes of the USM type in order to evaluate the largest influence of the geometrical parameters and the time delays on the meter performance.

This International Standard does not define any limits on uncertainty caused by field influences. Such limits are usually defined by the user according to the requirements of the application, by applicable application standards or by legal regulation. The uncertainty due to the installation is included in the total uncertainty (see Clause 5).

Tests in 9.2, 9.4, 9.5 and 9.6 shall be carried out on at least two sizes of meter. Ideally, the pipe diameters should differ by a factor of about 2. If this is not possible, the nominal pipe diameters shall differ by at least 100 mm.

The test in 9.5 is not required when a meter is only used in conjunction with a prover.

9.2 Repeatability and reproducibility

A calibration shall be carried out under undisturbed flow conditions with the following flowrates: 100 %, 70 %, 40 %, 25 %, 10 %, and 5 % of a flowrate chosen by the manufacturer (and obtainable in the calibration facility). These tests are based on flowrate, as opposed to Reynolds number, since flow variability increases with decreasing flowrate, independently of the Reynolds number.

Repeatability shall be measured for at least three flowrates (100 %, 25 % and 5 % of the maximum flowrate). For each of these flowrates, 10 single measurements shall be taken. The velocity, the volume measured, the duration and the error shall be reported. Repeatability is given from ISO 11631^[39] by

$$t_{95}s\sqrt{2}$$

where

s is the standard deviation of the n measured errors;

t_{95} is Student's t -statistic evaluated for $n - 1$ points.

To measure reproducibility under changed conditions of time, the same meter shall be tested under exactly the same installation conditions with a time difference of at least 1 week. The reproducibility shall be determined from the difference between two calibrations at least 1 week apart. Reproducibility conditions shall be reported.

The reproducibility over a continuous range of speeds of sound shall be determined to assess the effects of interference from acoustic and electric signals from correlated sources. The measurements shall be performed at a single constant pipe velocity of 1 m/s. The range of sound velocities shall be such that the number of wavelengths between two opposing transducers changes by 2. In other words, if f is the frequency of the acoustic signal:

$$\frac{l_p}{c} f = \frac{l_p}{c + \Delta c} f + 2 \Rightarrow \Delta c = \frac{2c^2}{f l_p - 2c} \quad (22)$$

This can often be achieved by changing the temperature of the liquid. For example, if water is used with an ultrasonic frequency of 1 MHz with a path length of 250 mm, slowly changing the temperature from 20 °C to 27 °C is sufficient. In order to cover the entire range, points approximately equally spaced in sound velocity should be measured. The relative deviation of flowrate versus sound velocity curve shall be reported.

9.3 Additional test for meters with externally mounted transducers

If the meter is externally mounted, the following additional test shall be performed.

The meter is calibrated in the following 12 pipes at the following flowrates: 100 %, 40 %, and 10 % of a flowrate¹⁾ chosen by the manufacturer (and obtainable in the calibration facility):

- a specific material (e.g. stainless steel) of one pipe size with three different wall thicknesses;
- in stainless steel of three pipe sizes with the same wall thickness (over the range the pipe diameters shall, if possible, be in a ratio of at least 3:1; if this is not possible, there shall be a range of at least 200 mm in diameter or the range of the use of the product if smaller than 200 mm);
- in carbon steel, ductile iron, PVC, PVDF, PE, and mortar-lined pipe of broadly similar pipe size and wall thickness from commercially available pipes.

The standard uncertainty is calculated from the measured errors (see ISO/IEC Guide 98-3:2008,^[43] Clause 4).

9.4 Assessing the uncertainty of a meter whose performance is predicted using a theoretical prediction procedure

When the meter factor is determined by a procedure other than a calibration under flowing conditions, an uncertainty assessment for this procedure shall be provided by the manufacturer.

One way to assess this uncertainty is to calibrate at least 10 meters in flowing conditions; these calibrations shall be witnessed by an independent person. The standard uncertainty is calculated from the measured errors.

9.5 Fluid-mechanical installation conditions

The manufacturer shall specify the maximum deviation S and the minimum length l_{\min} required to keep the deviation caused by a perturbation below S . The manufacturer may specify multiple pairs of values of S , l_{\min} . The minimum required length l_{\min} for each perturbation is determined by the tests defined in this subclause.

The baseline for reference flow conditions is determined by measuring the calibration factor in an installation $70D$ upstream of the meter preceded by a flow conditioner, itself preceded by $10D$ of straight pipe. If using a shorter length of straight pipe instead of $70D$ gives a sufficient baseline, a shorter length may be used. If the calibration factors with nD , $(n + 10)D$ and $(n + 20)D$ [or nD , $(n + 5)D$ and $(n + 10)D$] of straight pipe upstream are all within $0,3S$ (30 % of the specified maximum permitted deviation due to the upstream fitting) then nD is sufficient. Any error in the baseline affects the values of l_{\min} that are determined.

For the following standardized set of perturbations, the following tests shall be conducted:

- a) a single 90° bend (radius of curvature of $1,5D$):
 - 1) USM in normal position,
 - 2) USM rotated 90°,
 - 3) USM rotated 180°,
 - 4) USM rotated 270°;
- b) two 90° bends in perpendicular planes (radius of curvature of $1,5D$, without spacer between bends):
 - 1) USM in normal position,
 - 2) USM rotated 45° (this test is required at l_{\min} only),
 - 3) USM rotated 90°,
 - 4) USM rotated 135° (this test is required at l_{\min} only);
- c) a standard expander with an expansion in diameter of 2:3 or 3:4;

1) This flowrate is different in the different pipe sizes.

- d) a diameter step with magnitude 5 % giving an increase in inner diameter (or a larger value, if the manufacturer allows larger steps);
- e) if required by the manufacturer, a flow conditioner chosen and positioned by the manufacturer in combination with perturbations listed in a) to d).

The tests shall be conducted for at least two Reynolds numbers. A ratio of 5:1 between the two Reynolds numbers is ideal (e.g. 10^5 and 2×10^4). Relevant are the mean values of the three single measurements at each Reynolds number. All calculated mean deviations between the values in perturbed flow and the baseline shall be within S .

Tests shall be undertaken with the specified fittings at a series of lengths upstream of the upstream flange of an in-line meter or upstream of the first holder of a meter with externally mounted transducers: the lengths are $3D$, $5D$, $10D$, $15D$, $20D$, $25D$, $30D$, $40D$, and $50D$. To establish that the meter is acceptable for distances greater than or equal to nD , it shall be demonstrated that it is acceptable for nD and the next two longer lengths in the series; tests are not required at longer lengths.

9.6 Path failure simulation and exchange of components

Where there is a possibility that a meter remains in service in the event of path failure, the effect of the failure shall be determined at the flow calibration of the meter by simulating the failure of one or more paths. The test should be carried out at or around the mid-point of the expected operating range of the meter. During the test, the flowrate should be varied by 20 % of the flowrate to ensure that the meter responds appropriately.

If the instrument is designed to allow the exchange of parts without removal, the manufacturer shall demonstrate the capability of the meter to replace or relocate transducers, electronic parts, and software, without a significant change in meter performance. This has to be demonstrated for:

- the electronics;
- transducers of different path types.

When components are exchanged, the resulting shift in the mean error of the meter shall not be more than a value determined to ensure that the meter maintains the required uncertainty in terms of Clause 6.

10 Meter characteristics

10.1 Meter body, materials, and construction

10.1.1 Materials and manufacture

The meter body should be manufactured from materials that are compatible with the intended service. A USM with internal diameter equal to flange internal diameter shall be indicated as “full bore”. A USM with internal diameter smaller than flange internal diameter shall be indicated as “reduced bore”.

10.1.2 Ultrasonic ports

Since the measured liquid may contain some impurities (e.g. gases, other liquids or solids), transducer ports shall be designed so as to reduce the possibility of gases, other liquids or solids accumulating in the transducer ports.

To minimize the effects of gas or sediment, transducers should not be installed on the top or bottom of the pipe.

10.1.3 Anti-roll provision

The meter shall be designed so that the meter body does not roll when resting on a smooth surface with a slope of up to 10 % ($5,7^\circ$). This is to prevent damage to any protruding transducers and the electronic system when the USM is temporarily set on the ground during installation or maintenance work.

The meter shall be designed in such a way that easy and safe handling of the meter during transportation and installation is possible; however, the anti-roll provision alone is not sufficient during transportation. Hoisting eyes or clearance for lifting straps shall be provided.

10.1.4 Flow conditioner

A flow conditioner (a device intended to improve both the stability and the shape of the flow profile inside the USM), attached to the USM in such a way that it is not intended to be removed from the USM, is regarded as part of the USM. For the purposes of this International Standard, the combination of the flow conditioner and USM is regarded as the "USM".

A flow conditioner, not attached to the USM but intended always to be used in conjunction with it, together with the USM and the linking meter tube, forms a USM-package (USMP). In a bidirectional setup, a thermowell may also be part of the USMP. In a USMP, the flow conditioner is usually mounted at a distance of $3D$ to $10D$ upstream of the USM.

Any other flow conditioner upstream of a USMP is regarded as part of the installation or of the calibration facility. For the calibration facility baseline, see 9.5.

10.1.5 Markings

Markings are typically covered by national laws and standards. One may expect to find the following items on the nameplate:

- a) manufacturer, model number and serial number;
- b) meter size, flange class, and total mass (if the instrument is heavy);
- c) meter body design code and material, flange design code and material;
- d) maximum operating pressure and operating temperature range;
- e) maximum and minimum actual volume flowrate per hour;
- f) direction of positive or forward flow;
- g) orientation of the meter ("this side up");
- h) month and year manufactured are required unless they can be easily determined from the serial number;
- i) compliance with national standards.

Nameplates may include the following:

- 1) purchase order number or shop order number;
- 2) the legal metrology approval identification;
- 3) attestation that the meter is explosion-proof.

If the transducer ports are accessible, each transducer port shall be permanently marked with a unique designation for easy reference. If markings are stamped on to the meter body, low stress stamps may be used which produce a round-bottomed impression.

10.1.6 Corrosion protection

Immediately after production, the inner surface of the meter, spool pieces and flow conditioners should, if required, be protected against corrosion.

10.2 Transducers

10.2.1 General

The type of transducer shall be suitable for the application conditions, e.g. the viscosity of the fluid.

10.2.2 Marking

If the transducer ports are accessible, each transducer shall be permanently marked with a unique serial number.

10.2.3 Cable

If the USM is sensitive to the characteristics of the individual transducer cable, then the cable shall be treated as an integral part of the meter and shall be marked with a warning indicating which characteristic is not to be changed, e.g. length.

10.3 Electronics

10.3.1 General requirements

The electronic system of a USM usually includes power supplies, microcomputer, signal processing components, and ultrasonic transducer excitation circuits.

All electronic equipment shall comply with national standards that govern the electrical safety and response to electromagnetic and environmental influences. In addition, they may prescribe requirements for explosion-proof enclosures and intrinsically safe designs. These standards typically state that the instrument shall operate within specification over the entire range of environmental conditions. Compliance with such standards (e.g. FCC, CE, IEC, IP) is marked on the instrument. When an instrument is accepted for a particular installation, it shall be verified which standards cover this particular operation and if the instrument complies with them. Compliance with standards can be checked by inspecting the markings and the manufacturer documentation. In a particular installation, there may be requirements that go beyond national standards. In that case, compliance shall be verified on a case by case basis.

10.3.2 Power supply

The manufacturer shall specify the necessary power supply, the tolerance on the voltage variation and the power consumption. The reaction of the USM to power interruptions and voltage drops shall be specified.

10.3.3 Pulsating flow

The meter shall cope with non-steady flow. For that purpose, signals may be sent at a non-constant rate. The manufacturer shall specify the maximum flow fluctuation frequency.

10.3.4 Cable jackets and insulation

Cable jackets, rubber, plastics, and other exposed parts shall be resistant to ultraviolet light, water, oil, and grease.

10.3.5 Marking

Each electronic assembly shall be permanently marked with a unique version number for easy reference. A list of electronic assemblies including version number shall be kept up to date by the manufacturer as part of a reliable version management system.

10.4 Software

10.4.1 Firmware

Computer codes responsible for the control and operation of the meter shall be stored in a non-volatile memory. All flow-calculation constants and user-entered parameters shall also be stored in non-volatile memory (or memory with a battery back-up).

It shall be possible to verify all constants and parameters while the meter is in operation. A firmware check-sum or event log shall be provided to validate that no unauthorized changes have been made to the firmware.

The check-sum and firmware version shall be mentioned in the calibration reports.

10.4.1 is only a requirement for custody-transfer and fiscal meters.

10.4.2 Discontinuity

As the USM is an electronic meter, the firmware may introduce flow calculation discontinuities due, for example, to level settings. Therefore, the firmware shall be designed in such a way that flow calculation discontinuities are avoided.

10.4.3 Marking and version management

The manufacturer shall maintain a record of all firmware revisions including revision serial number, date of revision, applicable meter models and circuit board revisions, as well as a description of changes to firmware performed by them or by their representative.

The firmware revision number, revision date, serial number or check-sum shall be available for inspection of the firmware chip, display or digital communications port.

The manufacturer may offer firmware upgrades from time to time to improve the performance of the meter or to add additional features. The manufacturer shall notify the user if the firmware revision affects the accuracy of a flow-calibrated meter.

10.4.4 Inspection and verification functions

It shall be possible to view and to print the flow measurement configuration parameters used by the electronic system, e.g. calibration constants, meter dimensions, time-averaging period and sampling rate. Provisions shall be made to prevent an accidental or undetectable alteration of those parameters that affect the performance of the meter. Suitable provisions include a sealable switch or jumper, or a permanent programmable read-only memory chip with verifiable check-sum or event log alarms. For every event with the USM (calibration, repair, etc.) a full parameter list before and after the event shall be available at the measuring station.

When the indicated flowrate output is invalid, an "output invalid" alarm-status output shall be provided.

The following alarm-status outputs may be provided:

- 1) warning: when any of several monitored parameters fall outside normal operation for a significant length of time,
- 2) partial failure: when one or more of the multiple ultrasonic path results is not usable.

10.4.4 is only a requirement for custody-transfer and fiscal meters.

10.4.5 Input for diagnostics

As a minimum, the following measurements shall be provided for diagnostic purposes:

- a) non-linearized average axial flow velocity through the meter;
- b) flow velocity for each ultrasonic path (or equivalent for evaluation of the flowing velocity profile);

- c) speed of sound along each ultrasonic path;
- d) average speed of sound;
- e) averaging time interval;
- f) percentage of accepted pulses for each ultrasonic path;
- g) signal-to-noise ratio and gain control;
- h) status and measurement quality indicators;
- i) alarm and failure indicator;
- j) optionally, the linearized average axial flow velocity.

The meter shall be supplied with a facility for storing these values in a data file.

Some functions may require the use of additional tools.

10.5 Exchange of components

If it is not possible to replace or relocate transducers, electronic parts, and software without a significant change in meter performance (i.e. within the reproducibility specification), the meter shall be recalibrated. See 9.6.

Procedures to be used when such components have to be exchanged, including possible mechanical, electrical or other measurements and adjustments, shall be specified. Any change of parts without recalibration of the meter may lead to additional uncertainties, which shall be specified by the manufacturer.

If parts are replaced by newer or different versions, their advantages and disadvantages shall be specified. The manufacturer shall provide a reliable version management system.

10.6 Determination of density and temperature

10.6.1 Density

If there is a requirement to convert volume flow to either mass flow or volume flow under standard conditions, liquid density shall be determined.

Liquid density may be determined by:

- a) direct measurement;
- b) calculation from pressure, temperature and liquid composition;
- c) inferential measurement.

Provided that the performance requirements (see Clause 5) are met, a fixed value of density may be used.

10.6.2 Temperature measurement

Any temperature-measuring device shall not affect the performance of the USM; a thermowell should preferably be installed downstream of the USM. If the USM is bi-directional, then the thermowell should be at least 15*D* upstream of the USM.

The temperature-measuring device shall be such that it gives a measurement representative of the temperature at the meter. It is particularly important if standard volume or mass is required.

11 Operational practice

11.1 General

This clause is directed at the user, to ensure that the USM, once in service, continues to meet the expected performance requirements after its installation.

In contrast to many other meters, a USM can deliver extended diagnostic information through which it may be possible to verify its functionality. Owing to the extended diagnostic capabilities, this International Standard advocates the addition and use of automated diagnostics instead of labour-intensive quality checks.

For applications where high potential financial risks are matched by high accuracy expectations, it is necessary to incorporate a number of advanced diagnostic and audit trail procedures within a re-certification package. Optional diagnostic information systems or diagnostic programs embedded within the database computer or distributed control system provide a continuous verification of the functionality of the USM.

11.2 Audit process

An audit trail files key documents and key characteristics of the USM throughout its life cycle. See Figure 6.

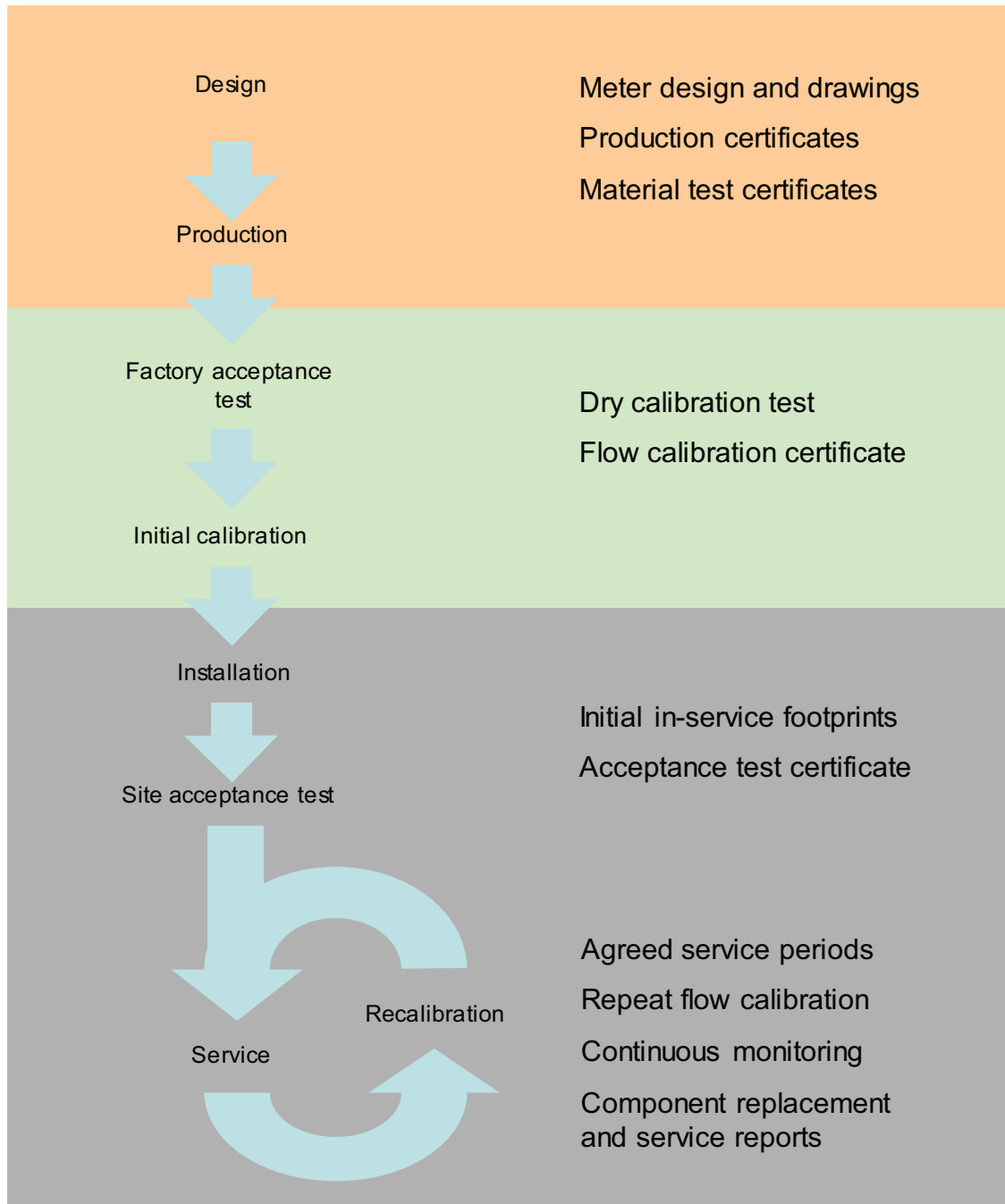

Figure 6 — Audit trail

An audit trail contains some or all of the following processes:

- manufacture;
- factory acceptance testing (FAT);
- calibration;
- field operation and condition-based monitoring;
- recalibration.

Documents produced by the above processes are:

- 1) production certificates;
- 2) test certificates;
- 3) calibration certificates;
- 4) parameter change certificates or reports;
- 5) component replacement certificates or reports;
- 6) inspection reports.

Characteristic indicators are deduced from measurement and diagnostic data as specified under 10.4.5:

- speed-of-sound footprints;
- trends in gain settings and other diagnostic data;
- inter-comparison results;
- log files.

11.3 Operational diagnostics

11.3.1 Speed of sound

11.3.1.1 General

When the liquid composition, temperature and pressure are measured, the reference speed of sound (RSOS) can be compared with the measured value. For water and other liquids for which accurate speed-of-sound data are available, the speed of sound is an excellent tool to monitor not only the ultrasonic liquid flowmeter, but also the other components in the system, such as the temperature transmitter.

The speed of sound measured by a USM, the “measured SOS” (MSOS), is influenced by:

- a) the liquid;
- b) the pressure (small dependence);
- c) the temperature;
- d) the geometry of the measurement section;
- e) the transit time measurement (by the meter).

11.3.1.2 Absolute speed-of-sound comparison

If both MSOS and RSOS are available, they may be compared: absolute comparison.

Differences between MSOS and RSOS may indicate:

- a) asynchronous determination of MSOS and RSOS due to analysis time lag;
- b) malfunction of:
 - 1) USM,
 - 2) temperature measurement;
- c) depositions on the transducer(s) or meter body which change the path length.

Statistical techniques may be helpful for monitoring MSOS and RSOS over time.

11.3.1.3 Relative speed-of-sound comparison; footprint

USMs with two or more paths may be monitored by comparison of the speed-of-sound values per path: relative comparison.

The advantages are:

- the measurement can be performed under flowing conditions;
- the calculation can be done automatically as part of a diagnostic package

The comparison may be displayed graphically as a “footprint”. As an example, in Figure 7 the footprint is shown from a five path ultrasonic liquid flowmeter, showing the relative deviations measured at the theoretical prediction procedure and flow calibration. In these figures, all the different relative deviations of the speed of sound from the various paths are shown. The relative deviations are numbered according to the path numbers; 5/1 means the speed of sound from path 5 divided by that of path 1, etc.

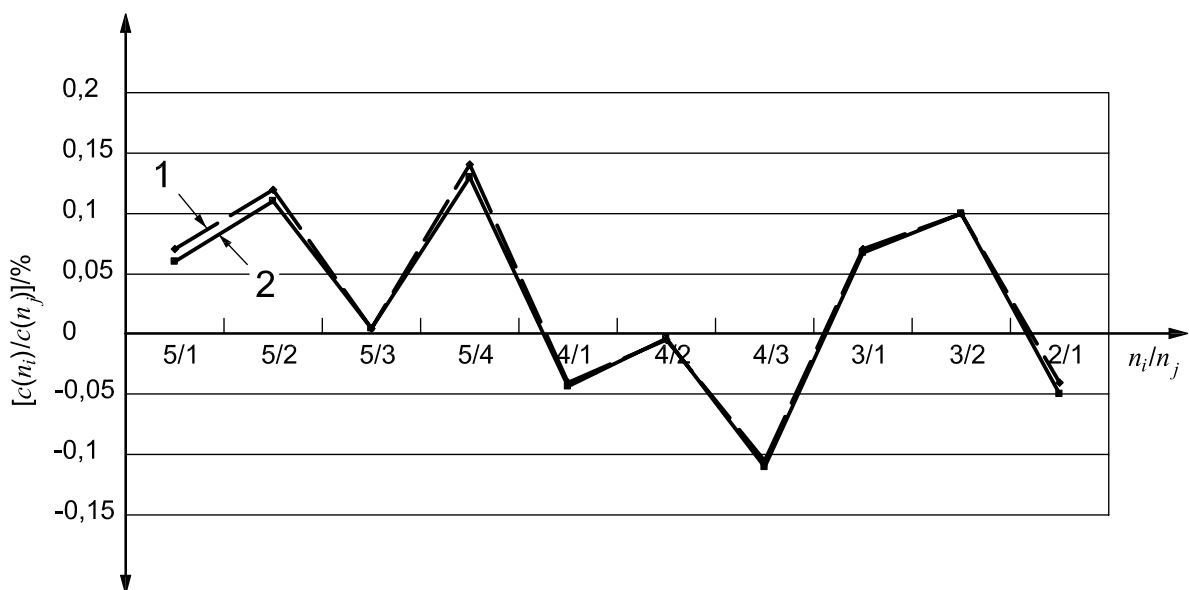

Key	
n_i	designation of path i ($i = 1 \dots 5$)
$c(n_i)$	SOS on path n_i
$[c(n_i)/c(n_j)]$	relative deviation in SOS ratio
1	theoretical prediction procedure
2	flow calibration

Figure 7 — Footprint: Ratio pattern determined during the theoretical prediction procedure and during the flow calibration at the calibration facility

This is just an example. Note that different graphs may be generated, dependent on the meter configuration, to serve as a footprint.

A change in the shape of the footprint over time may indicate malfunction of a path of the USM with a resulting potential for mismeasurement. Footprints from FAT, flow calibration and field may be compared in order to monitor changes in the behaviour of the USM.

11.3.2 Velocity ratios

The individual path velocities of the meter have unique relationships reflecting the flow profile that is produced by the pipe configuration. Except at low velocities or low Reynolds numbers, these relationships do not change

significantly over time in normal meter operating conditions and may therefore be monitored on line as a diagnostic tool.

11.3.3 Other parameters

Although the speed of sound (SOS) is one of the most important parameters to be used in verification, there are many more parameters that may be monitored in order to ensure optimum performance, and combinations of these may serve as the basis of an expert system.

11.4 Audit trail during operation; inter-comparison and inspection

11.4.1 Inter-comparison checks (with multiple meters in series)

If the USM is operated with another meter in series, e.g. via permanent serial installation or short-term serial installation, the output and key parameters from each meter can be monitored and compared to confirm agreement between the meters. If necessary, where 100 % redundancy has been provided as part of the system design, one of the meters can be designated the check meter and only introduced into service for this inter-comparison activity.

Where provision has been made for USMs to operate in series, either continually or for short periods, differences between the meters shall be confirmed at start-up and verified regularly during operation, using the integrated volume flowrate differences under metering conditions or standard conditions. As with all situations where meters of similar technology are used to verify each other, the potential for common-mode error shall be recognized.

The differences in integrated volume flowrate shall be evaluated according to control limits established for the specific inter-comparison method. If these differences exceed the control limits and prior to any action being taken, troubleshooting shall be performed to determine if possible which meter is faulty and also if any external effects may have had an impact on the performance of the meters.

ISO 17089-1:2010,^[41] Annex C gives an example from the reference meter method with two USMs in series.

11.4.2 Inspections

11.4.2.1 General

Monitoring based on measurement data leaves the USM undisturbed. However, there may be reasons for undertaking an internal inspection of the depressurized meter body and its transducers. In the case of insertion-type transducers, it may be possible to remove them for inspection independent of process line conditions.

11.4.2.2 Zero-flow checks

The USM is isolated from the production flow and the liquid velocity checked to confirm that the registration of that parameter on all the ultrasonic paths is zero. A zero flow check may only be attempted in the field if full isolation and temperature stability can be maintained. If either is suspect, then the check may be aborted.

When possible, the user may verify that the USM measures near zero when no liquid is flowing through the meter. When performing this test, the user may bypass any low-flow cut-off function, and be aware that any meter-run temperature differences cause thermal convection currents in the liquid inside the meter, which the USM may measure as a flowrate. With some types of meter, the speed-of-sound vertical gradient is an indicator of temperature gradient and convection problems.

A zero offset may be indicative of a more fundamental problem with the USM, or the user may wish to perform additional diagnostic checks as part of a repeat of the theoretical prediction procedure.

11.4.2.3 Visual Inspection

Deposits due to normal liquid transmission conditions, e.g. dirt, wax or sand, may affect the accuracy of the meter and should be avoided. The same effects may be experienced from rusting of untreated internal surfaces or defective internal coating. The internal surface and the wall roughness should therefore be monitored for

changes using optical (visual) methods as well as the meter diagnostics. The monitoring interval chosen should be dependent on the sensitivity of the USM as well as the expected changes in wall roughness. If the meter bore is clean and the original machining marks clearly visible, then there may not be a need or requirement to remeasure.

The bore of the USM may be inspected for contamination either by removing the meter from service or by employing a “bore-scope” or similar device to ensure that there has not been a particulate build-up or changes in surface finish which could affect the performance of the meter. Access to the inspection device may be through the line-pressure tapping or via purpose-built inspection ports in the upstream and downstream pipe spools adjacent to the meter. If the latter are employed, care should be taken to ensure that they do not produce local disturbances in the flowing liquid.

11.5 Recalibration

11.5.1 General

Depending on the outcome of diagnostics, internal company regulations or rules set forward by the authorities, USMs may need to be recalibrated.

11.5.2 Recalibration interval

The interval between successive recalibrations depends upon a number of issues including:

- a) the long-term reproducibility of the meter;
- b) commercial risk;
- c) accuracy requirements;
- d) the interpretation of diagnostic information as proposed in 11.3 and 11.4.

Once an initial recalibration interval has been adopted, new recalibration results may influence the length of the interval. Statistical techniques may be helpful.

11.5.3 Field recalibration

11.5.3.1 General

The effects of installation conditions and operating conditions on a USM can be reduced by calibrating the meter in the field. In general, the electronics used in modern USMs are not subject to significant drift. Moreover, transducers are commonly of the external type or are installed in a housing that isolates the transducer element from the fluid. Therefore, calibration is not generally required as a function of time, but may be required to reduce other influences on the calibration factor. Such influences can include a) to c).

- a) Installation effects, i.e. upstream hydraulics.

The potential magnitude of installation effects can be determined by performance testing (see Clause 9).

- b) Fluid properties and, in particular, changing viscosity.

This effect varies with meter design. To estimate the effects of changing viscosity, calibration data may be used, or an estimate may be made by reference to the data presented in Appendix B.

- c) Corrosion, erosion and deposition in the upstream pipe or measurement section.

Alteration of the surface of the upstream pipe may have an influence on K_p , see Annex B. Corrosion, erosion or contamination of the measurement section may alter both the cross-sectional area, A , and the path geometry factors.

Calibration of USMs in the field may be achieved by one of the following general methods:

- 1) calibration directly against a volumetric prover;

- 2) calibration using a volumetric prover and intermediate master meter;
- 3) calibration against a master meter.

In general, using a method that involves a volumetric prover results in lower uncertainty than relying on a master meter alone.

A stand-alone master meter may be incorporated into the metering system at the design stage and then used periodically to prove the duty meter(s). If this method is used, the master meter may itself be returned periodically to a calibration laboratory, or a mobile proving system could be used to calibrate the master meter. When a master meter is used, care should be taken to minimize the potential for “common-mode error”, i.e. an influence which is equal on both the duty meter(s) and the master meter. For example, in an application where contamination build-up is probable, then the master meter could be installed in such a way that it can be bypassed. The intent then is to keep the master meter in pristine condition, either by using it for shorter periods of time or by allowing it to be cleaned periodically.

11.5.3.2 Provers

Volumetric provers may be used to calibrate USMs in the field. In the past, these devices have mainly been used to calibrate mechanical meters such as turbine or positive displacement flowmeters, and it is important to recognize that the behaviour and requirements for USMs may differ.

USMs have no moving parts and hence are not subject to wear and tear in the way that a mechanical meter might be. Therefore there is no technical reason to specify that proving should be performed at a certain interval in time. However, regular proving may be mandated in some applications.

For USMs, proving can reduce the influence of velocity profile, viscosity, and temperature effects. The degree to which a USM is affected by changes in these is dependent on the meter design and can be evaluated by testing and/or analysis (see Clause 9 and Annex B). The provision of proving is also of benefit if changes to the internal condition of the meter are expected to occur.

Ultrasonic transit time meters generally sample the velocity on one or more paths, and then compute a volume flowrate, which is in turn provided as some form of output. Typically when used with a prover, the output is in the form of a volume-proportional pulse stream. The fact that there are several steps in the measurement and output process means that additional care may be required to ensure that proving can be carried out to the application requirements.

In turbulent flow, each sample of path velocity made by a USM is affected by the contributions to transit time that result from turbulent vortices or eddies along the path. This is a naturally occurring property of turbulent flow and can be dominant in terms of the short-term repeatability of the meter. Flow conditioning can alter the characteristics of turbulence upstream of the measurement paths and therefore can have either a positive or a negative impact on short-term repeatability.

For a given size and design of volumetric prover, the combined characteristics of the turbulence in the flow and the specific design of the USM together determine the level of repeatability that can be achieved. In this respect, if the calibration volume (and time) are increased, the repeatability improves.

The calibration volume of some volumetric provers, such as captive piston provers, is relatively small. As a result, it may be important to give greater consideration to the sampling and update rate employed in the flowmeter. For example, if the meter is designed to perform all its sampling, signal processing, calculation and output updating on a 1 s cycle, then it is clearly inappropriate for use with a prover where the calibration volume passes through the meter in an interval of 0,5 s.

As a general guide, when using volumetric provers, the sample rate should be as high as possible and there should be as little delay as possible in calculating the result and updating the output. Filtering or averaging of the output, as might be used in process control applications, should not be applied during calibration.

The objective of carrying out a number of proving runs is to validate, through statistics, that the average calibration factor obtained has an uncertainty consistent with the requirements of the application. In the past, when mechanical meters have been used, this requirement has been reduced to a simple rule such as achieving five runs with a spread in calibration factor, from minimum to maximum, of less than 0,05 %. In this example,

the uncertainty in the mean is approximately 0,027 %. For USMs, a more flexible approach is beneficial in order to enable the user to adopt a system design and proving routine to meet the requirements of the particular application. Formula (23) describes the relationship between the uncertainty in the mean, U , and the spread:

$$U = \frac{t_{95}R^*}{d^* \sqrt{n}} \quad (23)$$

where

- t_{95} is the value of the Student's t -probability distribution at 95 % confidence and $n - 1$ degrees of freedom;
- R^* is the range or repeatability spread (i.e. maximum minus minimum calibration factor in percentage terms);
- d^* is a range to standard deviation conversion factor for n samples, each sample in this case being a proving run.

This computation can be performed by introducing a range to uncertainty conversion factor, J , as follows:

$$J = \frac{U}{R^*} = \frac{t_{95}}{d^* \sqrt{n}} \quad (24)$$

Tabulated values of J are given in Table 3 for values of n up to 50. To calculate the allowable range or spread for a given number of runs, it is simply a case of dividing the required uncertainty by the appropriate value of J . For example, for an uncertainty of 0,05 % in 10 runs, the allowable range or spread is $0,05/0,234 = 0,214$ %. Similarly, if, for example, five runs are performed and the range of calibration factor obtained is 0,11 %, the estimated uncertainty, using $J = 0,537$, is 0,059 %.

Table 3 — Uncertainty conversion factor, J

Number of test points	Range to uncertainty conversion factor J	Target uncertainty in the mean value, examples			
		0,027 %	0,035 %	0,050 %	0,10 %
		Allowable range of calibration factor for the above uncertainty in the mean value			
3	1,477	0,018 %	0,024 %	0,034 %	0,068 %
4	0,776	0,035 %	0,045 %	0,064 %	0,129 %
5	0,537	0,050 %	0,065 %	0,093 %	0,186 %
6	0,417	0,065 %	0,084 %	0,120 %	0,240 %
7	0,344	0,078 %	0,102 %	0,145 %	0,290 %
8	0,296	0,091 %	0,118 %	0,169 %	0,338 %
9	0,261	0,104 %	0,134 %	0,192 %	0,384 %
10	0,234	0,115 %	0,149 %	0,214 %	0,427 %
11	0,213	0,127 %	0,164 %	0,234 %	0,469 %
12	0,196	0,138 %	0,178 %	0,255 %	0,509 %
13	0,182	0,148 %	0,192 %	0,274 %	0,548 %
14	0,171	0,158 %	0,205 %	0,293 %	0,586 %
15	0,160	0,168 %	0,218 %	0,312 %	0,623 %
16	0,152	0,178 %	0,231 %	0,330 %	0,659 %
17	0,144	0,187 %	0,243 %	0,347 %	0,694 %
18	0,137	0,197 %	0,255 %	0,364 %	0,728 %
19	0,131	0,206 %	0,267 %	0,381 %	0,762 %
20	0,126	0,214 %	0,278 %	0,397 %	0,794 %
25	0,105	0,258 %	0,334 %	0,477 %	0,954 %
30	0,091	0,296 %	0,384 %	0,548 %	1,097 %
35	0,081	0,332 %	0,430 %	0,615 %	1,230 %
40	0,074	0,366 %	0,474 %	0,678 %	1,355 %
45	0,068	0,398 %	0,516 %	0,737 %	1,475 %
50	0,063	0,429 %	0,556 %	0,794 %	1,589 %

11.5.4 As-found laboratory recalibration

11.5.4.1 General

Re-calibrations at an approved test facility require the meter to be removed from service and transported to the test facility. If production is to be maintained, there may also be a requirement to hold a spare meter in the field in order to maximize availability.

11.5.4.2 Handling in the field

In the field the following procedure is recommended:

- a) record a log file at flowing conditions (prior to zero flow and zero pressure conditions);
- b) record zero flow reading as in 11.4.2.2.;
- c) remove the USM or USMP;
- d) inspect, internally, the USM and adjacent meter spools as in 11.4.2.3 — a photographic record shall be kept;
- e) replace the USM with either a spare meter, a spool piece or blind flanges;

- f) the USM or USMP shall not be cleaned unless applicable health and safety regulations require it — if cleaning is performed this shall be recorded in the event log;
- g) prepare the USM for transportation: to prevent changes to wall roughness or contamination, the blind-flanged USM should be pressurized with nitrogen or equivalent techniques should be used, where practical.

11.5.4.3 Handling in the laboratory

In the laboratory the following procedure is recommended:

- a) inspect the USM — capture the situation photographically if necessary;
- b) if possible do not clean;
- c) mount the USM according to 8.3 — if the USM has been calibrated before, use identical upstream piping (preferably the same upstream pipe spools as in the original calibration);
- d) ensure alignment;
- e) avoid changing the USM parameters, i.e. make no adjustments;
- f) calibrate according to 8.3 using the same Reynolds number set points if the USM has been calibrated before.

If a USM has to be modified, it is recommended that an as-found calibration be performed prior to modification. After modification a new full calibration may not be necessary if the performance test permits, but verification should be carried out at least at one flowrate.

Annex A (normative)

Temperature and pressure correction

A.1 Temperature correction

For all meter types, the geometry-related temperature correction can be given as a straightforward analytical solution (see ISO 17089-1:2010,^[41] E.2.1). Owing to this, the correction has a very small uncertainty and the only uncertainties related to this correction are the uncertainties related to the material constants.

The flow correction factor due to a body temperature change, ΔT , is given by:

$$\frac{q_{V,true}}{q_{V,meas}} = (1 + \alpha\Delta T)^3 = \left(1 + 3\alpha\Delta T + 3(\alpha\Delta T)^2 + (\alpha\Delta T)^3\right) \quad (\text{A.1})$$

where

$$\Delta T = T_{op} - T_{cal}$$

α is the thermal expansion coefficient.

Other than in extreme situations, $\alpha\Delta T$ is generally very small and Formula (A.1) can be simplified to:

$$\frac{q_{V,true}}{q_{V,meas}} = 1 + 3\alpha\Delta T \quad (\text{A.2})$$

or alternatively, expressed as a relative correction term:

$$\left(\frac{\Delta q_V}{q_V}\right)_T = 3\alpha\Delta T \quad (\text{A.3})$$

Table A.1 gives typical values of thermal expansion coefficient for common body materials.

Table A.1 — Common thermal expansion coefficients in the 0 °C to 100 °C range

Material	Value, /°C
Stainless steel (304)	17×10^{-6}
Stainless steel (316)	16×10^{-6}
Stainless steel (420)	10×10^{-6}

The figures given in Table A.1 vary with both the temperature and the treatment process of the steel. For precise calculations, it is recommended that the data be obtained from the manufacturer.

A graphical presentation of Formula (A.3) is shown in Figure A.1 for two materials.

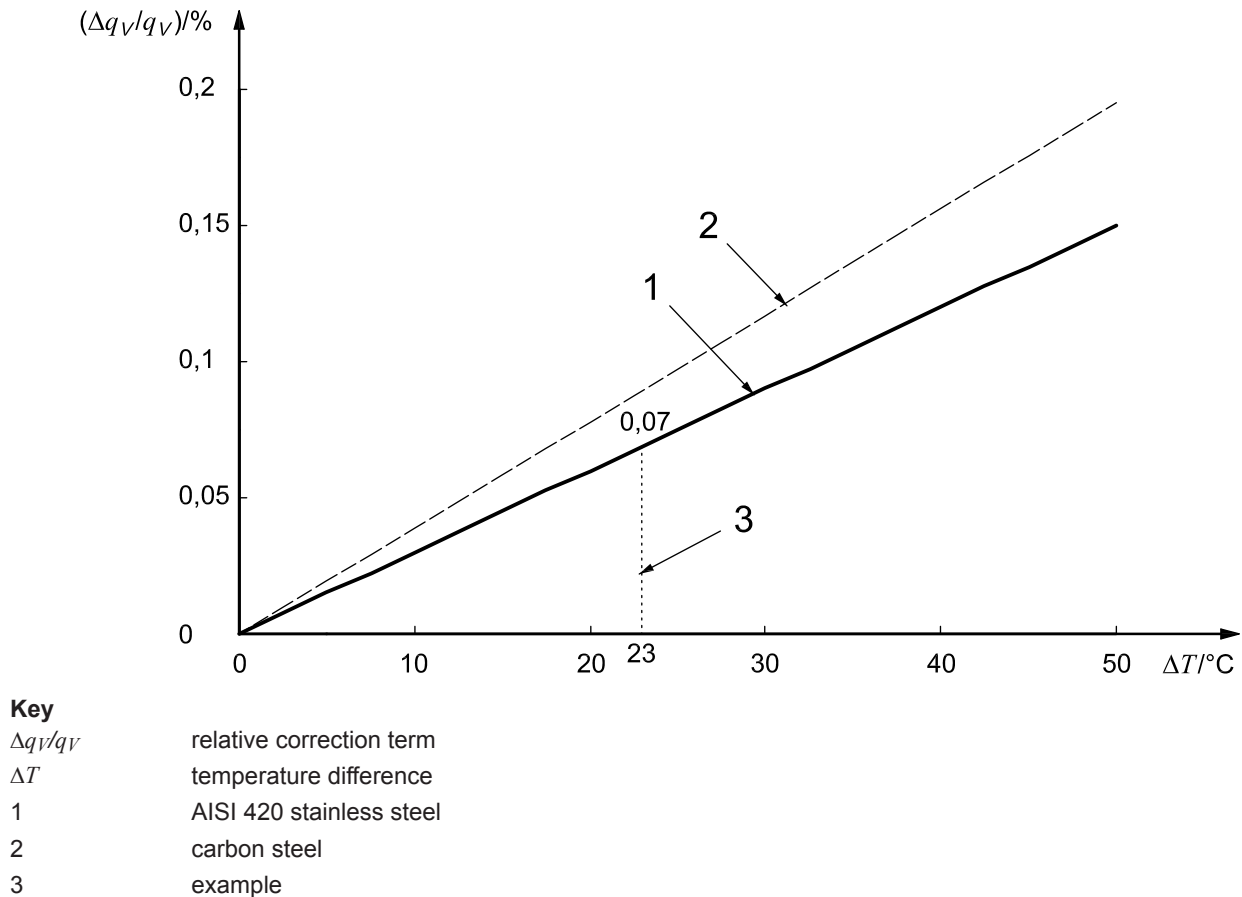

Figure A.1 — Temperature-related relative correction term for two example material types

Figure A.1 can be used to estimate quickly the percentage correction required for a given temperature change. The example point for a +23 °C temperature change with an AISI 420 stainless steel body shows a +0,07 % correction (i.e. the meter would underestimate the flow by 0,07 % without the correction). If ΔT is negative, $\Delta q_V/q_V$ is negative (i.e. the meter over-reads the flow).

A.2 Pressure correction

A.2.1 General

The geometry-related pressure correction is complex and depends on the design of the meter body, its end connections and the way the meter ends are supported in operation. Looking at the market, the various meter designs offered can be grouped into three broad categories:

- a) welded-in cylindrical body designs;
- b) meter bodies consisting of a pipe with welded-on flanges;
- c) non-cylindrical meter-body designs, e.g. those based on casting.

The following subclauses provide a means of making an initial estimate of the flow relative correction factor for any body type.

A.2.2 General simplified expression for any body type

As a first stage in estimating the pressure effects, a general basic expression can be derived assuming the meter body consists simply of a cylindrical pipe. An estimate of the maximum expected relative correction term due to a body pressure change, Δp , is (as described in ISO 17089-1:2010,^[41] E.2.2) given by:

$$\left(\frac{\Delta q_V}{q_V}\right)_{\text{body pressure, maximum}} = 4 \frac{\Delta r}{r} = 4 \left(\frac{R^2 + r^2}{R^2 - r^2} + \sigma \right) \frac{\Delta p}{E} \quad (\text{A.4})$$

where

r is the internal radius of the pipe;

R is the outside radius of the pipe;

σ is Poisson's ratio;

E is Young's modulus.

If the meter body is irregular or non-cylindrical (e.g. as might be the case for a cast body), then for the purposes of this initial estimate the value of outside radius, R , should be taken as the point where the wall is thinnest, since this gives the largest estimate of flow relative correction factor.

Formula (A.4) can be presented in graphical form as shown in Figure A.2 for a range of values of δ/r , i.e. the ratio of wall thickness to internal radius.

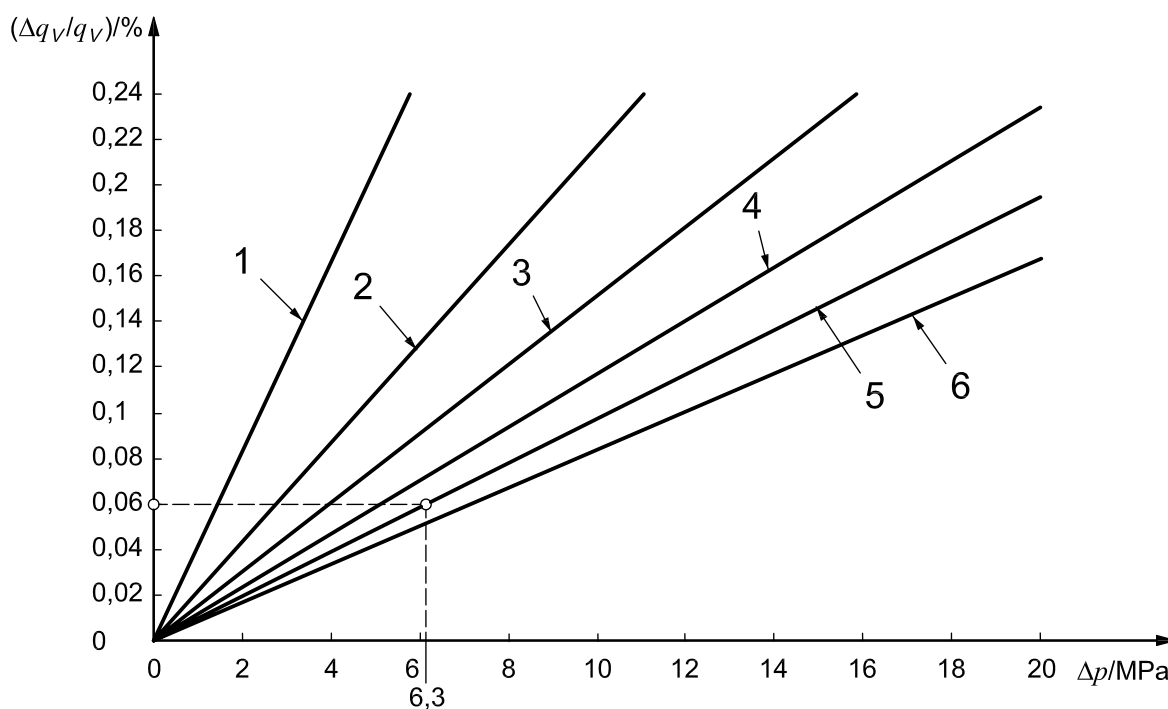

Key

	δ/r	
1	0,050	$\Delta q_V/q_V$ relative correction term
2	0,100	Δp pressure difference
3	0,150	r pipe internal radius
4	0,200	δ pipe wall thickness
5	0,250	
6	0,300	

Figure A.2 — Maximum expected pressure-related relative correction term for different δ/r ratios

Figure A.2 provides a rapid means of estimating the maximum expected flow relative correction term due to body pressure changes. The figure is plotted for a body material with a Young's modulus of 2×10^{11} Pa and a Poisson's ratio of 0,3. The example of a 63 bar (6,3 MPa) Δp shows the maximum expected pressure-induced relative correction term to be 0,06 % for $\delta/r = 0,25$. If Δp is negative, $\Delta q_V/q_V$ is negative (i.e. the meter over-reads the flow).

Since Formula (A.4) and Figure A.2 provide a maximum expected relative correction term, readers can, if they desire, go straight to A.4 (taking $K_E = K_S = 1$) to assess the significance of the relative correction factor, without the need of the refinement in the initial estimate provided in A.2.3 and A.2.4, since these result in a lower value for the flow relative correction factor.

A.2.3 Refinement in initial estimate to account for different meter body designs

Flanged ends or an irregular shape to the body stiffen the body compared with the simple cylindrical pipe approach used in A.2.2. Consequently, the body expansion and resulting flow relative correction factor are less than that given by Formula (A.4) and Figure A.2. To compensate for this local stiffening effect, a body "style correction factor", K_S , is used to give a revised estimate of the flow relative correction term:

$$\left(\frac{\Delta q_V}{q_V} \right)_{\text{bodypressure,rev1}} = K_S \left(\frac{\Delta q_V}{q_V} \right)_{\text{bodypressure,maximum}} \quad (\text{A.5})$$

K_S is always less than or equal to 1. The value of K_S to be used for a given body type is as follows:

- a) for a welded-in body with no flanges within $2R$ of the ultrasonic transducer locations, $K_S = 1$, i.e. the meter body behaves as a simple pipe;
- b) for a flanged meter body (e.g. consisting of two flanges welded to a pipe), or for a welded-in design where neighbouring flanges are within $2R$ of the transducer positions, the value of K_S has to be calculated as described in ISO 17089-1:2010,^[41] E.2.3;
- c) for irregularly shaped meter bodies, e.g. cast bodies, K_S is obtained as follows, based on an average flow relative correction factor:
 - 1) Formula (A.4), or Figure A.2, is used to obtain a second flow relative correction factor, y , but this time based on the thickest wall section;
 - 2) K_S is then calculated as $K_S = 0,5[1 + (y/x)]$ where x is the initial estimate based on the thinnest wall section.

A.2.4 Refinement in initial estimate for effects of end loading and end support or constraint

Formula (A.4) and Figure A.2 are based on the worst-case conditions for radial body expansion (no end loads and free ends). The effect of the best-case conditions (pressure end loads and free ends) for minimal radial body expansion can be taken into account by introducing an "end correction factor", K_E , given in Figure A.3 (for a Poisson's ratio of 0,3).

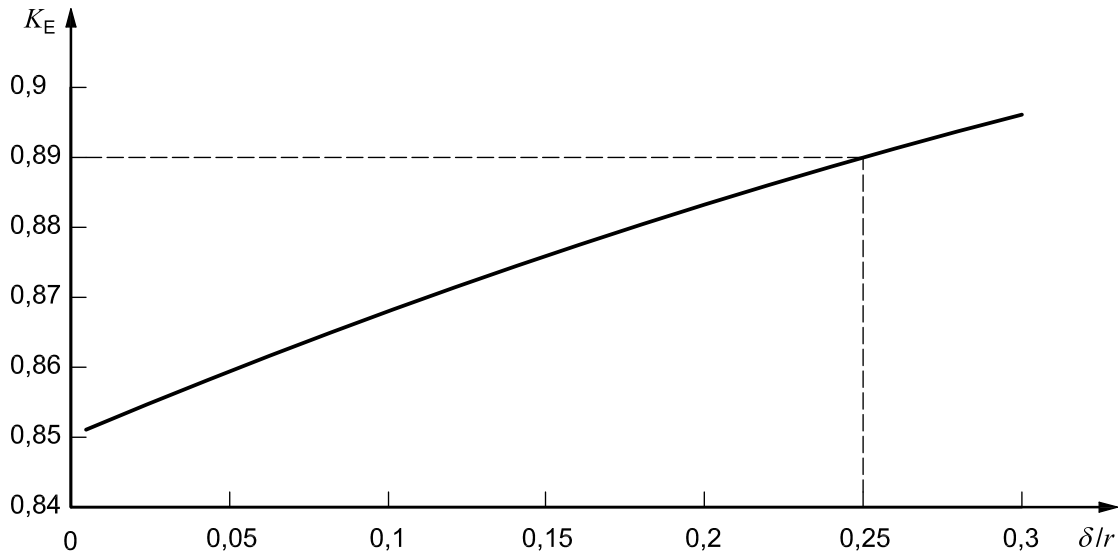

Key

K_E end correction factor

r inside pipe radius

δ pipe wall thickness

$$K_E = -0,122\ 9(\delta/r)^2 + 0,191\ 3(\delta/r) + 0,850\ 1$$

Figure A.3 — End loading and support correction factor, K_E

This is derived simply from the ratio of Formulae (E.12) and (E.14) in ISO 17089-1:2010.^[41] In the example in Figure A.3, $K_E = 0,89$ for $\delta/r = 0,25$. Note that the smallest value K_E can have is 0,85.

The flow relative correction factor $\Delta q_V/q_V$ then becomes:

$$\left(\frac{\Delta q_V}{q_V}\right)_{\text{bodypressure}} = K_E K_S \left(\frac{\Delta q_V}{q_V}\right)_{\text{bodypressure,maximum}} \quad (\text{A.6})$$

Note, Formula (A.6) gives an estimate of the expected minimum flow relative correction factor. It can therefore be used in combination with the maximum flow relative correction factor (i.e. with $K_E = K_S = 1$) to provide an initial estimate of the range or tolerance in expected flow relative correction factor.

A.3 Impact of temperature and pressure effects on the transducer ports

The combined impact of the transducer and the transducer port is normally an order of magnitude smaller than the effect on the meter body and can be neglected in most cases. However, for reference, ISO 17089-1:2010, E.2.5 provides a simple calculation method that includes an estimate of port effects. In these formulae, the transducer material coefficients have to be known, and for these the manufacturer has to be consulted.

A.4 Total effect of temperature and pressure

The initial estimate of the combined flow relative correction factor due to a temperature and a pressure difference is given by:

$$\left(\frac{\Delta q_V}{q_V}\right)_{\text{combined,estimate}} = \left(\frac{\Delta q_V}{q_V}\right)_{\text{temperature}} + K_E K_S \left(\frac{\Delta q_V}{q_V}\right)_{\text{bodypressure,maximum}} \quad (\text{A.7})$$

If the flow relative correction factor is deemed not significant, then it can be neglected.

If, however, the flow relative correction factor is deemed significant and hence requires correction, the detailed calculation as described in A.5 needs to be performed to obtain a more precise flow relative correction factor. If calculations in A.2.3 and A.2.4 were omitted in the estimate for pressure effect, a repeat estimate can be performed using those subclauses to provide a lowered estimate before reassessing the need for the more detailed calculation.

A.5 Detailed calculation procedure

ISO 17089-1:2010,^[41] Annex E describes the detailed calculation and includes the temperature and pressure effects on the transducer ports as well as effects on the meter body of body style and end loading.

The ratio between $q_{V,cal}$ at a reference calibration condition and $q_{V,op}$ under operational conditions can be written (see ISO 17089-1:2010,^[41] E.1) as a flow correction factor, $q_{V,op}/q_{V,cal}$, given by:

$$\frac{q_{V,op}}{q_{V,cal}} = \left(\frac{d_{op}}{d_{cal}} \right)^2 \left(\frac{l_{p,op}}{l_{p,cal}} \right)^2 \left(\frac{X_{cal}}{X_{op}} \right) \quad (\text{A.8})$$

where X is the transducer axial separation.

The detailed calculation contains estimates of extremes and allows the flow correction and relative correction factors to be described in either of the following equivalent forms:

$$q_{V,op}/q_{V,cal} = x,xxx \times \pm x,xxx \times \quad (\text{A.9})$$

$$\Delta q_V/q_V = x,xx \% \pm x,xx \% \quad (\text{A.10})$$

Stating the final flow correction factor, $q_{V,op}/q_{V,cal}$, to four decimal places and flow relative correction factor, $\Delta q_V/q_V$, to two decimal places is representative of the general level of accuracy of the calculation method. Since there is always some uncertainty as to the actual end-loading conditions on the meter, the flow estimates are never more precise than the tolerance values given in Formulae (A.9) and (A.10).

For meter bodies that are generally cylindrical in shape and either are welded in or have attached flanges, ISO 17089-1:2010,^[41] Annex E provides a simple procedure based on direct calculation from the physical characteristics of the meter. ISO 17089-1:2010,^[41] Annex E provides a worked example of such a direct calculation.

Where the meter body is such that the body shape is not a simple cylinder, flanges take up a significant proportion of the total body length or ports are not simple tubes, a finite element (FE) model provides a more accurate estimate of the body and port dimensions and the consequent flow relative correction factor obtained from Formula (A.8) than given by the direct calculations of ISO 17089-1:2010,^[41] E.2.2–E.2.4. ISO 17089-1:2010,^[41] E.3 provides guidance on the use of FE modelling to predict the temperature and pressure expansion effects.

Regardless of the complexity of the meter, an FE model of the body and ports can be used. It is recommended that Formulae (E.12) to (E.15) of ISO 17089-1:2010,^[41] including any body-style correction effects as in ISO 17089-1:2010,^[41] E.2.3 where relevant, be used as a means of checking the predicted dimensions from the FE model to provide added confidence in the FE model. Formula (A.8) is still used to predict the flow relative correction factor along each path based on the changes in physical dimensions between conditions.

Annex B (informative)

Effect of a change of roughness

This annex enables the user to estimate the effect of a roughness change on the calibration factor or velocity profile correction factor. This annex cannot be used to calculate the effect of a roughness change on a reduced-bore meter.

The factors in this annex have been calculated using the well known log law of the wall which can be used to describe velocity profiles as a function of the friction factor. The friction factor used here is calculated as a function of the relative pipe roughness and Reynolds number, using the explicit function published in Reference [45]. For further information on the derivation of the equations, the reader is referred to Reference [46]. The results for the two, three, four, and five path meter designs have been computed using the well-known spacing and weightings applied according to the rules of Gauss–Jacobi integration (sometimes referred to as Chebyshev integration); see, for example, Reference [25].

Tables are provided in the following for five different meter designs and guidance on applicability is given above each table. The process for estimating the effect of a roughness change is as follows:

- a) first calculate an appropriate pipe Reynolds number for the application (see 4.6);
- b) then calculate the relative roughness, k_r , for the initial condition (guidance on roughness calculation is given below);
- c) select the value of $K_{p_initial}$ for the initial condition from the appropriate table, using the calculated values of k_r and Re_D . Interpolate between the values in the table if necessary;
- d) calculate the relative roughness for the changed pipe condition;
- e) select the value of $K_{p_present}$ for the present condition from the appropriate table, using the calculated values of k_r and Re_D . Interpolate between the values in the table if necessary;
- f) calculate the percentage deviation using the formula:

$$\frac{K_{p_initial} - K_{p_present}}{K_{p_present}} \times 100$$

EXAMPLE 1

- meter details: meter with two diametric paths;
- fluid: water with a kinematic viscosity of 1 cSt (10^{-6} m²/s);
- pipe internal diameter: 100 mm;
- flow velocity: 5 m/s;
- initial roughness: 0,03 mm;
- present roughness: 0,3 mm;

Initial condition, $Re_D = 500\,000$, $k_r/D = 0,000\,3$, $K_{p_initial} = 0,946\,5$

Present condition, $Re_D = 500\,000$, $k_r/D = 0,003$, $K_{p_present} = 0,932\,8$

Deviation = 1,47 %

EXAMPLE 2

- meter details: four path chordal meter;

- fluid: oil with a kinematic viscosity of 10 cSt (10^{-5} m²/s);
- pipe internal diameter: 200 mm;
- flow velocity: 5 m/s;
- initial roughness: 0,06 mm;
- present roughness: 0,6 mm;

Initial condition, $Re_D = 100\,000$, $k_r/D = 0,000\,3$, $K_{p_initial} = 0,998\,03$

Present condition, $Re_D = 100\,000$, $k_r/D = 0,003$, $K_{p_present} = 0,997\,65$

Deviation = 0,038 %

Table B.1 applies for meters where all paths traverse a diameter of the cross-section, including single and multipath meters with external transducers.

Table B.1 — Diametric paths meters

Relative roughness	Pipe Reynolds number				
	10 000	25 000	100 000	500 000	50 000 000
0,000 01	0,927 8	0,935 4	0,944 1	0,951 6	0,961 2
0,000 03	0,927 8	0,935 3	0,944 0	0,951 1	0,958 1
0,000 10	0,927 6	0,935 0	0,943 4	0,949 5	0,953 8
0,000 30	0,927 3	0,934 4	0,941 9	0,946 5	0,948 7
0,001 00	0,926 0	0,932 3	0,938 0	0,940 7	0,941 7
0,003 00	0,923 0	0,927 8	0,931 5	0,932 8	0,933 3
0,010 00	0,915 1	0,918 1	0,920 0	0,920 6	0,920 8

Table B.2 applies for meters where all paths traverse the cross-section along paths that have their centre approximately half-way between the centre of the pipe and the pipe wall; this includes some common two-path meter designs.

Table B.2 — Mid-radius paths meters

Relative roughness	Pipe Reynolds number				
	10 000	25 000	100 000	500 000	50 000 000
0,000 01	0,988 02	0,989 34	0,990 86	0,992 13	0,993 75
0,000 03	0,988 01	0,989 33	0,990 83	0,992 05	0,993 24
0,000 10	0,987 99	0,989 29	0,990 73	0,991 78	0,992 50
0,000 30	0,987 92	0,989 18	0,990 47	0,991 26	0,991 65
0,001 00	0,987 71	0,988 82	0,989 81	0,990 27	0,990 44
0,003 00	0,987 16	0,988 02	0,988 66	0,988 90	0,988 98
0,010 00	0,985 75	0,986 29	0,986 62	0,986 73	0,986 77

Table B.3 applies for meters with the paths at two chordal positions, one of these being the diameter. This is typical of some three path meter designs, where one path is set on the diameter and the other two are equally spaced on either side of the diameter path. It also applies to other multipath designs where the additional paths lie either on the diameter or at the same distance from the centre as the non-diametric paths.

Table B.3 — Paths at two chordal positions, including the diameter

Relative roughness	Pipe Reynolds number				
	10 000	25 000	100 000	500 000	50 000 000
0,000 01	0,992 27	0,993 13	0,994 11	0,994 93	0,995 97
0,000 03	0,992 27	0,993 12	0,994 09	0,994 87	0,995 64
0,000 10	0,992 25	0,993 09	0,994 03	0,994 71	0,995 17
0,000 30	0,992 21	0,993 02	0,993 86	0,994 37	0,994 62
0,001 00	0,992 07	0,992 79	0,993 43	0,993 73	0,993 84
0,003 00	0,991 71	0,992 27	0,992 69	0,992 84	0,992 89
0,010 00	0,990 80	0,991 15	0,991 36	0,991 44	0,991 46

Table B.4 applies for meters with the paths at two chordal positions, both of which are offset from the diameter. This is typical of some four path meter designs, where one pair of paths is set at one distance either side of the centre of the pipe and the other pair of paths is set at a second distance either side of the centre of the pipe. It also applies to other multipath designs where all paths lie on either the first or the second distance from the centre of the pipe.

Table B.4 — Paths at two chordal positions, offset from the diameter

Relative roughness	Pipe Reynolds number				
	10 000	25 000	100 000	500 000	50 000 000
0,000 01	0,997 51	0,997 79	0,998 11	0,998 37	0,998 71
0,000 03	0,997 51	0,997 79	0,998 10	0,998 35	0,998 60
0,000 10	0,997 51	0,997 78	0,998 08	0,998 30	0,998 45
0,000 30	0,997 49	0,997 75	0,998 03	0,998 19	0,998 27
0,001 00	0,997 45	0,997 68	0,997 89	0,997 98	0,998 02
0,003 00	0,997 33	0,997 51	0,997 65	0,997 70	0,997 71
0,010 00	0,997 03	0,997 15	0,997 22	0,997 24	0,997 25

Table B.5 applies for meters with the paths at three chordal positions, one of these being the diameter. This is typical of some five path meter designs, where one path is on a diameter, one pair of paths is set at one distance either side of the diameter and the other pair of paths is set at a second distance either side of the diameter. It also applies to other multipath designs where all paths lie on either the diameter, the first or the second distance from the centre of the pipe.

Table B.5 — Paths at three chordal positions, including the diameter

Relative roughness	Pipe Reynolds number				
	10 000	25 000	100 000	500 000	50 000 000
0,000 01	0,995 57	0,996 06	0,996 63	0,997 10	0,997 69
0,000 03	0,995 56	0,996 06	0,996 61	0,997 06	0,997 51
0,000 10	0,995 56	0,996 04	0,996 58	0,996 97	0,997 23
0,000 30	0,995 53	0,996 00	0,996 48	0,996 77	0,996 92
0,001 00	0,995 45	0,995 86	0,996 23	0,996 40	0,996 47
0,003 00	0,995 25	0,995 57	0,995 81	0,995 90	0,995 93
0,010 00	0,994 72	0,994 92	0,995 05	0,995 09	0,995 10

The relative roughness (k_r/D) required for the tables is obtained by dividing the absolute value of the roughness by the pipe diameter. If in fact Ra is measured, then k_r is approximately obtained by multiplying Ra by π .

Some typical pipe roughness, k_r , values are provided below for guidance:

- new machined steel pipe, glass, copper, brass: 0,005 mm;
- new steel pipe: 0,03 mm;
- lightly corroded steel: 0,2 mm;
- new cast-iron pipe: 0,5 mm;
- concrete pipe, severely corroded steel: 2 mm.

Annex C (informative)

Example of uncertainty calculations

The purpose of this annex is to demonstrate how the general procedure described in Clause 6 can be applied to concrete examples. All calculations here are based on the methods presented in ISO/IEC Guide 98-3:2008.^[43] There is no rigorous separation in the treatment of type A and B uncertainties.

C.1 Uncertainty calculation for a calibrated non-refracting chordal multipath meter

C.1.1 Mathematical model

From Formulae (21) and (12), the measurand is given by:

$$q_V = K K_p A \sum_{i=1}^n w_i v_i \quad (\text{C.1})$$

$$v_i = \frac{l_{p,i}}{2 \cos \phi_i} \frac{\Delta t_i}{(t_{\text{me_up},i} - t_{0,i})(t_{\text{me_dn},i} - t_{0,i})} = K_{g,i} \frac{\Delta t_i}{(t_{\text{me_up},i} - t_{0,i})(t_{\text{me_dn},i} - t_{0,i})} \quad (\text{C.2})$$

K_g is the path geometry factor introduced in 6.2.5. For this uncertainty calculation it is assumed that the time difference Δt is small compared with the times measured upstream and downstream. Therefore they can be replaced by the average transit time t_{tr} upstream and downstream:

$$v_i = K_{g,i} \frac{\Delta t_i}{(t_{\text{me_up},i} - t_{0,i})(t_{\text{me_dn},i} - t_{0,i})} \approx K_{g,i} \frac{\Delta t_i}{(t_{\text{tr},i} - t_{0,i})^2} \quad (\text{C.3})$$

Uncertainties in the delay time t_0 can be viewed as uncertainties in the transit time. In that case we can simplify this even more if we redefine t_{tr} to include the delay time correction.

$$v_i \approx K_{g,i} \frac{\Delta t_i}{t_{\text{tr},i}^2} \quad (\text{C.4})$$

The simplified form of Formula (C.1) now becomes

$$q_V \approx K K_p A \sum_{i=1}^n \left(w_i K_{g,i} \frac{\Delta t_i}{t_{\text{tr},i}^2} \right) \quad (\text{C.5})$$

For simplicity, it is assumed that all products

$$w_i K_{g,i} \frac{\Delta t_i}{t_{\text{tr},i}^2}$$

are equal. Even though this would be very wrong for the actual flow calculation, for an uncertainty calculation this assumption has in many cases only minor consequences. This allows a further simplification:

$$q_V \approx K K_p A K_g \frac{\Delta t}{t_{\text{tr}}^2} \quad (\text{C.6})$$

C.1.2 Results from performance tests

Assume that the manufacturer has published the following data from *performance* testing:

- instrument outer diameter: 219,1 mm;
- instrument wall thickness: 5,0 mm;
- instrument inner diameter: $219,1 - 2 \times 5,0 = 209,1$ mm;
- temperature expansion coefficient: $17 \times 10^{-6} \text{ K}^{-1}$ (uncertainty: 5 %);
- pressure expansion coefficient: $3 \times 10^{-6} \text{ bar}^{-1}$ ($3 \times 10^{-5} \text{ MPa}^{-1}$) (uncertainty: 25 %);
- expanded uncertainty of the test facility: 0,05 %.

The calibration under reference conditions using water at approximately room temperature is given in Table C.1; the maximum flowrate is 0,2 m³/s (or 720 m³/h or a velocity of 5,75 m/s).

Table C.1 — Calibration under reference conditions at different flowrates

Flow indication	100 %	70 %	40 %	25 %	10 %	5 %
Flowrate (reference)	0,197	0,151	0,079 3	0,051 0	0,019 3	0,010 2
Reference volume	20,178 1	20,183 0	20,179 9	20,180 0	10,331 0	10,330 0
Measured volume	20,168 0	20,183 0	20,181 9	20,184 0	10,336 2	10,350 7
Temperature	17,2	17,3	17,4	17,4	17,5	17,5
Deviation	-0,05 %	0,00 %	0,01 %	0,02 %	0,05 %	0,20 %
Velocity	5,737	4,397	2,309	1,485	0,562	0,297
Reynolds number	1 115 433	854 976	449 004	288 767	109 278	57 753

The repeatability of the 10 measurements is calculated and given in Table C.2.

Table C.2 — Results of repeatability calculation at different flowrates

Flowrate	100 %	25 %	5 %
Repeatability	0,09 %	0,13 %	0,19 %
Standard deviation	0,03 %	0,04 %	0,06 %

Uncertainty due to a zero flow offset is specified as 1 mm/s.

Influence of interference from acoustic and electric signals from correlated sources measured as the amplitude of the deviation versus sound velocity curve: 0,1 % of velocity

Measurements were repeated 1 month later and were all within 0,1 % (reproducibility).

Disturbance tests (as specified in 9.6) show that l_{\min} is $10D$ for a maximum deviation S of 0,2 % and $25D$ for a maximum deviation S of 0,1 %.

All measurements were performed at approximately 17,5 °C and at a gauge pressure of 3 bar (300 kPa).

C.1.3 Installation conditions

Assume a maximum velocity of 3,5 m/s (440 m³/h). The liquid used in the installation has a kinematic viscosity of $3 \times 10^{-6} \text{ m}^2/\text{s}$. Assume that the meter is installed at a distance of $15D$ from the nearest upstream disturbance. Temperature is 75 °C and the gauge pressure 24 bar (2,4 MPa).

C.1.4 Evaluation of the contributory variances

C.1.4.1 General

The application of ISO/IEC Guide 98-3:2008,^[43] Formula 10 to Formula (C.6) yields:

$$u^2(q_V) = c_K^2 u^2(K) + c_{K_p}^2 u^2(K_p) + c_A^2 u^2(A) + c_{K_g}^2 u^2(K_g) + c_{t_{tr}}^2 u^2(t_{tr}) + c_{\Delta t}^2 u^2(\Delta t) \quad (C.7)$$

Here it is more convenient to work with relative uncertainties. In that case the formula becomes:

$$\begin{aligned} \frac{u^2(q_V)}{q_V^2} = & c_K^2 \frac{K^2}{q_V^2} \frac{u^2(K)}{K^2} + c_{K_p}^2 \frac{K_p^2}{q_V^2} \frac{u^2(K_p)}{K_p^2} + c_A^2 \frac{A^2}{q_V^2} \frac{u^2(A)}{A^2} + c_{K_g}^2 \frac{K_g^2}{q_V^2} \frac{u^2(K_g)}{K_g^2} + \\ & c_{\Delta t}^2 \frac{\Delta t^2}{q_V^2} \frac{u^2(\Delta t)}{\Delta t^2} + c_{t_{tr}}^2 \frac{t_{tr}^2}{q_V^2} \frac{u^2(t_{tr})}{t_{tr}^2} \end{aligned} \quad (C.8)$$

Using partial derivatives:

$$c_K \frac{K}{q_V} = c_{K_p} \frac{K_p}{q_V} = c_A \frac{A}{q_V} = c_{K_g} \frac{K_g}{q_V} = c_{\Delta t} \frac{\Delta t}{q_V} = 1 \quad (C.9)$$

$$c_{t_{tr}} \frac{t_{tr}}{q_V} = -2 \quad (C.10)$$

C.1.4.2 Uncertainties of the calibration factor $u(K)$, the cross-sectional area $u(A)$ and the geometry factor $u(K_g)$

Assume that the instrument is calibrated between Reynolds numbers 25 000 and 250 000. Assume that the expanded uncertainty of the calibration facility is equal to 0,05 % with a level of confidence of 95 %. The nearest upstream disturbance in the calibration facility is at $40D$. Assume that the calibration temperature is 35 °C and the gauge pressure is 7 bar (700 kPa).

The standard uncertainty of the calibration facility is calculated from its expanded uncertainty:

$$\frac{U_{95}(q_{V,\text{ref}})}{q_{V,\text{ref}}} = 0,05 \% \Rightarrow \frac{u(q_{V,\text{ref}})}{q_{V,\text{ref}}} \approx \frac{U_{95}(q_{V,\text{ref}})}{2q_{V,\text{ref}}} = 0,025 \% \quad (C.11)$$

It is assumed that the cross-sectional area and the path geometry do not change after calibration. Thus the uncertainties $u(A)$, $u(K_g)$ are removed by the calibration.

Pressure and temperature affect the cross-sectional area and the path geometry. The influence on flow is known and can be corrected for. The uncertainty of this correction can be treated as an additional uncertainty in the calibration factor K .

The calibration factor K now depends on pressure and temperature. The correction for body expansion due to temperature and pressure is given in Annex A:

$$K_{pT} = (1 + 3\alpha\Delta T)(1 + \beta\Delta p) \quad (C.12)$$

The combined standard uncertainty of the temperature and pressure correction is thus given by:

$$u^2(K_{pT}) = \left(\frac{\partial K_{pT}}{\partial \Delta T} \right)^2 u^2(\Delta T) + \left(\frac{\partial K_{pT}}{\partial \alpha} \right)^2 u^2(\alpha) + \left(\frac{\partial K_{pT}}{\partial \Delta p} \right)^2 u^2(\Delta p) + \left(\frac{\partial K_{pT}}{\partial \beta} \right)^2 u^2(\beta) \quad (C.13)$$

$$u^2(K_{pT}) = (3\alpha)^2 u^2(\Delta T) + (3\Delta T)^2 u^2(\alpha) + \beta^2 u^2(\Delta p) + \Delta p^2 u^2(\beta) \quad (\text{C.14})$$

Assuming 5 % standard uncertainty on α and 25 % standard uncertainty on β , and calculating ΔT and Δp from the difference between calibration and installed conditions and reasonable uncertainties in pressure and temperature measurements:

$$\alpha = 17 \times 10^{-6} \text{ K}^{-1}, \beta = 3 \times 10^{-6} \text{ bar}^{-1} (3 \times 10^{-5} \text{ MPa}^{-1}), \Delta T = 40 \text{ K},$$

$$\Delta p = 17 \text{ bar} (1,7 \text{ MPa}), u(\alpha) = 8,5 \times 10^{-7} \text{ K}^{-1}, u(\beta) = 7,5 \times 10^{-7} \text{ bar}^{-1} (7,5 \times 10^{-6} \text{ MPa}^{-1}), \quad (\text{C.15})$$

$$u(\Delta T) = 0,5 \text{ K}, u(\Delta p) = 0,25 \text{ bar} (25 \text{ kPa})$$

$$K_{pT} = (1 + 3\alpha\Delta T)(1 + \beta\Delta p) \approx 1,002 09$$

$$u^2(K_{pT}) = (3\alpha)^2 u^2(\Delta T) + (3\Delta T)^2 u^2(\alpha) + \beta^2 u^2(\Delta p) + \Delta p^2 u^2(\beta) \quad (\text{C.16})$$

$$u(K_{pT}) \approx 0,011\%$$

The combined standard uncertainty of the calibration factor thus is:

$$\frac{u^2(K)}{K^2} = \frac{u^2(K_{pT})}{K_{pT}^2} + \frac{u^2(q_{V,\text{ref}})}{q_{V,\text{ref}}^2} \Rightarrow \frac{u(K)}{K} \approx 0,027\% \quad (\text{C.17})$$

C.1.4.3 Uncertainty in the velocity profile, $u(K_p)$

The uncertainty caused by the flow profile is taken from the perturbation test results of the performance test. The meter is installed in the calibration facility at $40D$ after a disturbance. From performance tests we know that this adds an expanded uncertainty of approximately 0,1 % and a standard uncertainty of half that. In the actual installation, the distance to the first upstream disturbance is $15D$. This causes an extra penalty of 0,1 % (half of the number of the performance tests)

$$\frac{u(K_p)}{K_p} \approx \sqrt{(0,05\%)^2 + (0,1\%)^2} \approx 0,11\% \quad (\text{C.18})$$

C.1.4.4 Uncertainty of the time differences, $u(\Delta t)$

The uncertainty of the individual time differences is almost never given explicitly. It is derived from the repeatability obtained in the performance tests and from measurement of the influence of correlated sources. For the calculation in C.1.4.4 the worst case value of 0,06 % for the standard deviation in the repeatability test is taken. Because this already includes the summation of different acoustic paths, no adjustment for correlation between individual paths is required. The influence of the correlated sources was measured as an amplitude of 0,1 %. The actual uncertainty is thus about half this value. It is found that:

$$\frac{u^2(\Delta t)}{\Delta t^2} = (0,06\%)^2 + (0,05\%)^2 \Rightarrow \frac{u(\Delta t)}{\Delta t} \approx 0,078\% \quad (\text{C.19})$$

In addition to this, there is the uncertainty due to the zero offset. This uncertainty is specified as 1 mm/s by the manufacturer. Its contribution could be incorporated in the uncertainty, $u(\Delta t)$, but this is inconvenient. It can best be expressed as an uncertainty in the flow q_V :

$$\frac{u(q_V)}{q_V} = \frac{\pi D^2 u(v_0)}{4 \times q_V} \quad (\text{C.20})$$

At 0,5 m/s the relative uncertainty in the flow (based on the 1 mm/s specified by the manufacturer) amounts to 0,2 %; at 5 m/s it amounts to only 0,02 %.

Note that zero flow offsets are not easily determined on an installed instrument. This calculation assumes a factory-determined zero offset. If the zero flow offset is measured again after installation, it is necessary that

the flow (both the average flow and flow due to residual swirl and convection) in the installation is significantly less than the 1 mm/s uncertainty specified by the manufacturer. In most cases, it is impossible to guarantee this.

C.1.4.5 Uncertainties of the transit time measurement system $u(t_{tr})$ and the delay time $u(t_0)$

The manufacturer has specified the relative uncertainty of the transit time measurement as 10^{-5} . This gives:

$$\frac{u(t_{tr})}{t_{tr}} \approx 0,001\% \quad (C.21)$$

In many cases, the clock from all paths is derived from the same source. In that case, the uncertainties $u(t_{tr})$ from all paths are fully correlated.

Assume the manufacturer has specified the uncertainty in the delay time: $u(t_0) = 0,1 \mu\text{s}$. This uncertainty comes on top of the uncertainty in the transit time. The transit times of this instrument are not given. The transit time may be estimated as

$$c = 1300 \text{ m/s}, \quad l_p = 1,5D = 1,5 \times 209,1 \text{ mm} = 313,65 \text{ mm} \quad (C.22)$$

$$t_{tr} = l_p/c \approx 241 \mu\text{s}, \quad u(t_{tr}) \approx 10^{-5} \times t_{tr} \approx 0,00241 \mu\text{s}$$

Clearly this is much smaller than $0,1 \mu\text{s}$. The relative uncertainty is thus of the order of

$$u(t_{tr})/t_{tr} \approx 0,1 \mu\text{s}/241 \mu\text{s} \approx 0,041\% \quad (C.23)$$

This uncertainty needs more careful consideration. Delay times are typically measured only once. The value is then a *constant* in Formula (C.2), and all deviations end up in the meter constant. If the instrument is used at exactly the same sound velocity as during calibration, there is no deviation. Because this is typically not the case, there is some residual deviation, but it is less than the value given in C.21. The value in C.21 is thus an overestimation of the uncertainty.

C.1.5 Combined standard uncertainty

Table C.3 summarizes the results from the calculations in the preceding.

C.2 Uncertainty calculation for a meter with externally mounted transducers

C.2.1 Mathematical model

From Formulae (21) and (19), the measurand is given by:

$$q_V = KK_p A v_i \quad (C.24)$$

$$v_i = \frac{c_t}{\cos \phi_t} \frac{\Delta t}{t_{me_up} + t_{me_dn} - 2t_0} = K_g \frac{\Delta t}{t_{me_up} + t_{me_dn} - 2t_0} \quad (C.25)$$

The meter is installed on an existing pipe in the field. Therefore it is not flow-calibrated. Thus the calibration factor is $K = 1$, and the uncertainty $u(K) = 0$. K_g is the path geometry factor introduced in 6.2.5. For this uncertainty calculation, it is assumed that the time difference Δt is small compared with the times measured upstream and downstream. Therefore they can be replaced by the average transit time t_{tr} upstream and downstream:

$$v_i \approx K_g \frac{\Delta t}{2(t_{tr} - t_0)} \quad (C.26)$$

Table C.3 — Combined standard uncertainty

Standard uncertainty component $u(x_i)$	Source of uncertainty	Value of standard uncertainty		Sensitivity factors		Contribution	
		$u(x_i)$	$\frac{u(x_i)}{x_i}$	$\frac{c_i}{q_V}$	$c_i \frac{x_i}{q_V}$	0,5 m/s	5 m/s
$u(K)$	Calibration						
$u(q_{V,ref})$	Calibration facility		0,025 %		1	0,025 %	0,025 %
$u(\Delta T)$	Temperature difference	0,5 K		3α		0,003 %	0,003 %
$u(\alpha)$	Temperature expansion coefficient		5 %		$3\alpha\Delta T$	0,010 %	0,010 %
$u(\Delta p)$	Pressure difference	0,25 bar (25 kPa)		β		0,000 %	0,000 %
$u(\beta)$	Pressure expansion coefficient		25 %		$\beta\Delta p$	0,001 %	0,001 %
$u(A)$	Cross-sectional area		0		1	0	0
$u(K_g)$	Geometry factor		0		1	0	0
$u(K_p)$	Velocity profile		0,11 %		1	0,112 %	0,112 %
$u(\Delta t)$	Time difference (repeatability)		0,075 % — 0,058 %		1	0,075 %	0,058 %
$u(v_0)$	Zero flow offset	1 mm/s		$\frac{\pi D^2}{4 \times q_V}$		0,200 %	0,020 %
$u(t_{tr})$	Transmission time		0,041 %		2	0,083 %	0,083 %
$\frac{u(q_V)}{q_V} = \sqrt{\sum_j \left[\frac{c_j}{q_V} u(x_j) \right]^2}$						0,256 %	0,155 %
$\alpha = 1,7 \times 10^{-5} \text{K}^{-1}$, $\beta = 3 \times 10^{-6} \text{bar}^{-1} (3 \times 10^{-5} \text{MPa}^{-1})$, $\Delta T = 40 \text{ K}$, $\Delta p = 17 \text{ bar} (1,7 \text{ MPa})$, $c_{cal} = 1300 \text{ m/s}$, $D = 0,209 \text{ m}$							

Figure C.1 gives the expanded uncertainty ($k = 2$) over a range of mean velocities.

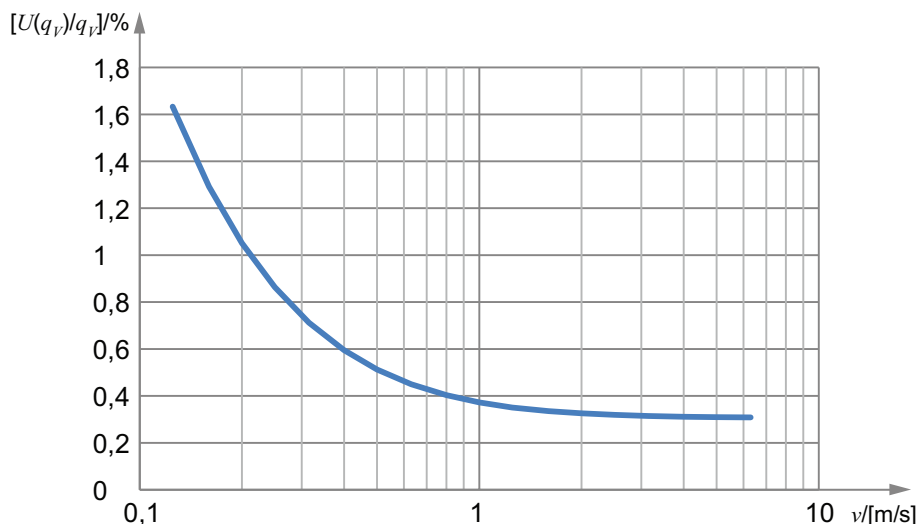

Key
 $U(\Delta q_v/q_v)$ expanded uncertainty in volume flowrate
 v path velocity

Figure C.1 — Percentage expanded uncertainty in volume flowrate for an example of a calibrated non-refracting chordal multipath meter

C.2.2 Results from performance tests

Assume that the manufacturer has published data from performance testing as given in this subclause. The repeatability of the 10 measurements is calculated and given in Table C.4.

Table C.4 — Results of repeatability calculation at different flowrates

Flowrate	100 %	25 %	5 %
Repeatability	0,19 %	0,25 %	0,38 %
Standard deviation	0,06 %	0,08 %	0,12 %

Uncertainty due to a zero flow offset is specified as 5 mm/s.

Influence of interference from acoustic and electric signals from correlated sources measured as the amplitude of the measurement deviation in dependence of sound velocity change: 0,1 % of velocity.

Measurements were repeated 1 month later and were all within 0,1 % (reproducibility).

Disturbance tests after a single 90° bend (as specified in 9.5) show that l_{\min} is 10D for a maximum deviation S of 2 % and 30D for a maximum deviation S of 0,8 %.

Based on the test as specified in 9.3 and 9.4, the expanded uncertainty of the geometry factor is calculated as $U(K_g) = 0,6 \%$, $k = 2$. The standard uncertainty, therefore, is $u(K_g) = 0,3 \%$.

All measurements were performed at approximately 17,5 °C and at a gauge pressure of 3 bar (300 kPa).

C.2.3 Installation conditions

The following values are used in this example:

- pipe outer diameter: 219,1 mm;
- pipe wall thickness: 5,0 mm;

- fluid: water;
- path velocity: 3,5 m/s;
- fluid temperature: 35 °C;
- fluid pressure: 3 bar (300 kPa);
- inflow conditions: 30D after a single 90° bend.

C.2.4 Evaluation of the contributory variances

C.2.4.1 General

The application of ISO/IEC Guide 98-3:2008,^[43] Formula 10 to Formulae (C.24) and (C.26), with $K = 1$ according to C.2.1, yields:

$$u^2(q_V) = c_{K_p}^2 u^2(K_p) + c_A^2 u^2(A) + c_{K_g}^2 u^2(K_g) + c_{t_{tr}}^2 u^2(t_{tr}) + c_{t_0}^2 u^2(t_0) + c_{\Delta t}^2 u^2(\Delta t) \quad (C.27)$$

Here it is more convenient to work with relative uncertainties. In that case, the formula becomes:

$$\begin{aligned} \frac{u^2(q_V)}{q_V^2} = & c_{K_p}^2 \frac{K_p^2}{q_V^2} \frac{u^2(K_p)}{K_p^2} + c_A^2 \frac{A^2}{q_V^2} \frac{u^2(A)}{A^2} + c_{K_g}^2 \frac{K_g^2}{q_V^2} \frac{u^2(K_g)}{K_g^2} + \\ & c_{t_{tr}}^2 \frac{t_{tr}^2}{q_V^2} \frac{u^2(t_{tr})}{t_{tr}^2} + c_{t_0}^2 \frac{t_0^2}{q_V^2} \frac{u^2(t_0)}{t_0^2} + c_{\Delta t}^2 \frac{\Delta t^2}{q_V^2} \frac{u^2(\Delta t)}{\Delta t^2} \end{aligned} \quad (C.28)$$

The relative sensitivities are:

$$c_{K_p} \frac{K_p}{q_V} = c_A \frac{A}{q_V} = c_{K_g} \frac{K_g}{q_V} = c_{\Delta t} \frac{\Delta t}{q_V} = 1 \quad (C.29)$$

$$c_{t_{tr}} \frac{t_{tr}}{q_V} = \frac{-t_{tr}}{t_{tr} - t_0} \approx -1 \quad (C.30)$$

$$c_{t_0} \frac{t_0}{q_V} = \frac{t_0}{t_{tr} - t_0} \quad (C.31)$$

In the following, the individual uncertainty contributions in Formula (C.28) are evaluated.

C.2.4.2 Uncertainty in the velocity profile, $u(K_p)$

The uncertainty caused by the flow profile is taken from the perturbation test results of the performance test. The meter is installed at 30D after a 90° bend. From performance tests, it is known that this adds an expanded uncertainty of 0,8 % and a standard uncertainty of half that.

$$\frac{u(K_p)}{K_p} \approx 0,4 \% \quad (C.32)$$

C.2.4.3 Uncertainty of the cross-sectional area, $u(A)$

The cross-sectional area of the pipe is calculated from the outer diameter and the wall thickness.

$$A = \frac{\pi}{4} (D_o - 2\delta)^2 \quad (C.33)$$

The outer diameter and the wall thickness are measured when the meter is installed on the pipe. The uncertainty of the cross-sectional area, $u(A)$, depends on the uncertainty of the outer diameter, $u(D_o)$, and of the wall

thickness, $u(\delta)$. The influence of temperature and pressure is negligible, because the geometry is measured at operational temperature and pressure. The application of ISO/IEC Guide 98-3:2008,^[43] Formula 10 to Formula (C.33) yields:

$$\begin{aligned}
 u(A)^2 &= \left(\frac{\partial A}{\partial D_o}\right)^2 u(D_o)^2 + \left(\frac{\partial A}{\partial \delta}\right)^2 u(\delta)^2 \\
 &= c_{A,D_o}^2 u(D_o)^2 + c_{A,\delta}^2 u(\delta)^2 \\
 \frac{u(A)^2}{A^2} &= c_{A,D_o}^2 \frac{D_o^2}{A^2} \frac{u(D_o)^2}{D_o^2} + c_{A,\delta}^2 \frac{w^2}{A^2} \frac{u(\delta)^2}{\delta^2}
 \end{aligned}
 \tag{C.34}$$

The sensitivities $c_{A,i}$ are given as follows:

$$\begin{aligned}
 c_{A,D_o} &= \frac{\partial A}{\partial D_o} = \frac{2A}{D_o - 2\delta} \approx \frac{2A}{D_o}; & c_{A,D_o} \frac{D_o}{A} &= 2 \\
 c_{A,\delta} &= \frac{\partial A}{\partial \delta} = \frac{-4A}{D_o - 2\delta} \approx \frac{-4A}{D_o}; & c_{A,\delta} \frac{\delta}{A} &= \frac{-4\delta}{D_o}
 \end{aligned}
 \tag{C.35}$$

Table C.5 summarizes the evaluation of Formula (C.34). The standard uncertainty of the wall thickness is assumed to be $u(\delta) = 0,1$ mm. The standard uncertainty of the outer diameter is assumed to be $u(D_o) = 0,5$ mm.

Table C.5 — Uncertainty of the cross-sectional area, $u(A)$

Standard uncertainty component	Source of uncertainty	Value of standard uncertainty		Sensitivity factor	Contribution
$u(x_i)$		$u(x_i)$	$\frac{u(x_i)}{x_i}$	$c_i \frac{x_i}{A}$	$\frac{c_i x_i}{A} \frac{u(x_i)}{x_i}$
$u(D_o)$	outer diameter	5×10^{-4}	0,23 %	2	0,46 %
$u(\delta)$	wall thickness	10^{-4}	1,67 %	$-4 \frac{\delta}{D_o} = 0,11$	0,18 %
		Standard uncertainty		$\frac{u(A)}{A} =$	0,49 %

C.2.4.4 Uncertainty of the geometry factor, $u(K_g)$

The standard uncertainty of the geometry factor according to the results of the performance testing is $u(K_g) = 0,3$ % (see C.2.2). The temperature dependency of K_g is assumed to be largely compensated for by the meter. The remaining uncertainty due to temperature is negligible in this example because the installation is near ambient temperature.

C.2.4.5 Uncertainty of the time difference, $u(\Delta t)$

The uncertainty of the time difference is derived from the repeatability obtained in the performance tests and from measurement of the influence of correlated sources. Furthermore the zero offset adds a contribution. For this example, the worst case value of $u_{rep}(\Delta t)/\Delta t = 0,12$ % for the standard deviation in the repeatability test is assumed. The influence of the correlated sources was measured as an amplitude of 0,2 %. The standard uncertainty $u_{CS}(\Delta t)/\Delta t$ is thus about half this value. The zero offset is specified as $u_0(\Delta t) = 5$ mm/s, which is 0,14 % expanded and 0,07 % standard uncertainty of the path velocity of $v_i = 3,5$ m/s. Therefore

$$\begin{aligned}
 \frac{u(\Delta t)}{\Delta t} &= \sqrt{\frac{u_{rep}^2(\Delta t)}{\Delta t^2} + \frac{u_{CS}^2(\Delta t)}{\Delta t^2} + \frac{u_0^2(\Delta t)}{\Delta t^2}} = \sqrt{(0,12\%)^2 + (0,1\%)^2 + (0,07\%)^2} \\
 \frac{u(\Delta t)}{\Delta t} &= 0,17\%
 \end{aligned}
 \tag{C.36}$$

C.2.4.6 Uncertainty of the delay time, $u(t_0)$

The delay time is the sum of twice the transit time in the transducer's coupling wedge, t_t , and twice the transit time in the pipe wall, t_w . The transit time in the pipe wall is calculated by the meter from the path length and the sound velocity of the pipe wall. The path length is derived from the speed of sound and the geometry factor K_g using Snell's law. The influence of temperature on the uncertainty is assumed to be negligible because the fluid temperature is near the ambient temperature. Thus the following formula holds:

$$t_0 = 2t_t + 2t_w = 2t_t + \frac{2t_w}{c_w} = 2t_t + \left(2\delta / c_w \sqrt{1 - \frac{c_w^2}{K_g^2}} \right) \quad (\text{C.37})$$

The uncertainty of the delay time, $u(t_0)$, depends on the uncertainties of the delay in the coupling wedge, $u(t_t)$, of the geometry factor, $u(K_g)$, of the thickness of the pipe wall, $u(\delta)$, and of the pipe wall SOS, $u(c_w)$. The application of ISO/IEC Guide 98-3:2008,^[43] Formula 10 to Formula (C.37) yields:

$$\begin{aligned} u(t_0)^2 &= \left(\frac{\partial t_0}{\partial t_t} \right)^2 u(t_t)^2 + \left(\frac{\partial t_0}{\partial K_g} \right)^2 u(K_g)^2 + \left(\frac{\partial t_0}{\partial \delta} \right)^2 u(\delta)^2 + \left(\frac{\partial t_0}{\partial c_w} \right)^2 u(c_w)^2 \\ &= c_{t_0, t_t}^2 u(t_t)^2 + c_{t_0, K_g}^2 u(K_g)^2 + c_{t_0, \delta}^2 u(\delta)^2 + c_{t_0, c_w}^2 u(c_w)^2 \end{aligned} \quad (\text{C.38})$$

The sensitivities $c_{t_0, i}$ are given as follows:

$$c_{t_0, t_t} = \frac{\partial t_0}{\partial t_t} = 2; \quad c_{t_0, t_t} \frac{t_t}{t_0} = \frac{2t_t}{t_0} \quad (\text{C.39})$$

$$c_{t_0, K_g} = \frac{\partial t_0}{\partial K_g} = \frac{-2c_w \delta}{\left[1 - \left(c_w^2 / K_g^2 \right) \right]^{3/2} K_g^3} = -\frac{2t_w^3 c_w^4}{\delta^2 K_g^3} \quad (\text{C.40})$$

$$c_{t_0, K_g} \frac{K_g}{t_0} = -\frac{2t_w^3 c_w^4}{\delta^2 K_g^2 t_0}$$

$$c_{t_0, \delta} = \frac{\partial t_0}{\partial \delta} = \frac{2t_w}{\delta}; \quad c_{t_0, \delta} \frac{\delta}{t_0} = \frac{2t_w}{t_0} \quad (\text{C.41})$$

$$c_{t_0, c_w} = \frac{\partial t_0}{\partial c_w} = -\left(2\delta / c_w^2 \sqrt{1 - \frac{c_w^2}{K_g^2}} \right) + \left[2\delta / K_g^2 \left(1 - \frac{c_w^2}{K_g^2} \right)^{3/2} \right] = -\frac{2t_w}{c_w} + \frac{2t_w c_w}{K_g^2 - c_w^2} \quad (\text{C.42})$$

$$c_{t_0, c_w} \frac{c_w}{t_0} = \left(-\frac{2t_w}{c_w} + \frac{2t_w c_w}{K_g^2 - c_w^2} \right) \frac{c_w}{t_0}$$

Table C.6 summarizes the evaluation of Formula (C.38). The uncertainty of the delay in the coupling wedge is specified as $u(t_t) = 0,5 \%$. The uncertainty of the geometry factor, $u(K_g)$, is as shown in C.2.4.4. The uncertainty of the pipe wall thickness is assumed to be $u(\delta) = 0,1 \text{ mm}$. The uncertainty of the pipe wall speed of sound is assumed to be $u(c_w) = 20 \text{ m/s}$. With the shear wave speed of sound of carbon steel $c_w = 3\,230 \text{ m/s}$, the relative uncertainty is $u(c_w) = 0,62 \%$:

Table C.6 — Uncertainty of the delay time, $u(t_0)$

Standard uncertainty component	Source of uncertainty	Value of standard uncertainty		Sensitivity Factor	Contribution
$u(x_i)$		$u(x_i)$	$\frac{u(x_i)}{x_i}$	$c_i \frac{x_i}{t_0}$	$\frac{c_i x_i}{t_0} \frac{u(x_i)}{x_i}$
$u(t_t)$	delay time in coupling wedge		0,25 %	$\frac{2t_t}{t_0} = 0,74$	0,18 %
$u(K_g)$	geometry factor		0,30 %	$\frac{-2t_w^3 c_w^4}{\delta^2 K_g^2 t_0} = -0,34$	-0,10 %
$u(\delta)$	wall thickness	10^{-4}	1,67 %	$\frac{2t_w}{t_0} = 0,26$	0,43 %
$u(c_w)$	speed of sound in wall	20	0,62 %	$\left(-\frac{2t_w}{c_w} + \frac{2t_w c_w}{K_g^2 - c_w^2} \right) \frac{c_w}{t_0} = 0,08$	0,05 %
		Standard uncertainty		$\frac{u(t_0)}{t_0} =$	0,48 %

C.2.4.7 Uncertainty of the transit time measurement system, $u(t_{tr})$

The manufacturer has specified the relative expanded uncertainty of the transit time measurement as $u_{rel}(t_{tr}) = 10^{-4}$ and an additional absolute contribution of $u_{abs}(t_{tr}) = 0,2T_0$, where T_0 is the signal period. The standard uncertainty is half of these numbers. Since the frequency is 1 MHz and the transit time is 319×10^{-6} s, this gives:

$$\frac{u(t_{tr})}{t_{tr}} = \sqrt{\left(0,5 \times 10^{-4}\right)^2 + \left(\frac{0,1 \times 10^{-6}}{319 \times 10^{-6}}\right)^2} = 0,03 \% \quad (C.43)$$

C.2.5 Combined standard uncertainty

Table C.7 summarizes the results from the calculation above. As can be seen in the last column, the main contributions are due to the uncertainties in the velocity profile, the cross-sectional area and the geometry factor. The uncertainty with varying path velocity is shown in Table C.8. The contribution of the uncertainty in time difference is increasing with decreasing path velocity. The other contributions remain constant. Figure C.2 shows this in graphical form.

Table C.7 — Total uncertainty of the volume flow

Standard uncertainty component	Source of uncertainty	Value of standard uncertainty		Sensitivity factor	Contribution
$u(x_i)$		$u(x_i)$	$\frac{u(x_i)}{x_i}$	$c_i \frac{x_i}{q_V}$	$\frac{c_i x_i}{q_V} \frac{u(x_i)}{x_i}$
$u(K_p)$	velocity profile		0,40 %	1	0,40 %
$u(A)$	cross-sectional area		0,49 %	1	0,49 %
$u(K_g)$	geometry factor		0,30 %	1	0,30 %
$u(\Delta t)$	time difference		0,17 %	1	0,17 %
$u(t_0)$	delay time		0,48 %	$\frac{t_0}{t_{tr} - t_0} = 0,07$	0,04 %
$u(t_{tr})$	transit time		0,03 %	-1	-0,03 %
		Standard uncertainty		$\frac{u(q_V)}{q_V} =$	0,72 %
		Expanded uncertainty ($k = 2$) (95 %)			1,45 %

Table C.8 — Total uncertainty of the volume flow with varying path velocity

Standard uncertainty component	Source of uncertainty	Path velocity, v_i , m/s			
		0,3	1,0	3,5	5,0
$u(x_i)$		Contribution $\frac{c_i x_i}{q_V} \frac{u(x_i)}{x_i}$			
$u(K_p)$	velocity profile	0,40 %	0,40 %	0,40 %	0,40 %
$u(A)$	cross-sectional area	0,49 %	0,49 %	0,49 %	0,49 %
$u(K_g)$	geometry factor	0,30 %	0,30 %	0,30 %	0,30 %
$u(\Delta t)$	time difference	0,85 %	0,29 %	0,17 %	0,16 %
$u(t_0)$	delay time	0,04 %	0,04 %	0,04 %	0,04 %
$u(t_{tr})$	transit time	-0,03 %	-0,03 %	-0,03 %	-0,03 %
	Standard uncertainty $\frac{u(q_V)}{q_V} =$	1,10 %	0,76 %	0,72 %	0,72 %
	Expanded uncertainty ($k_r = 2$) (95 %)	2,20 %	1,52 %	1,45 %	1,44 %

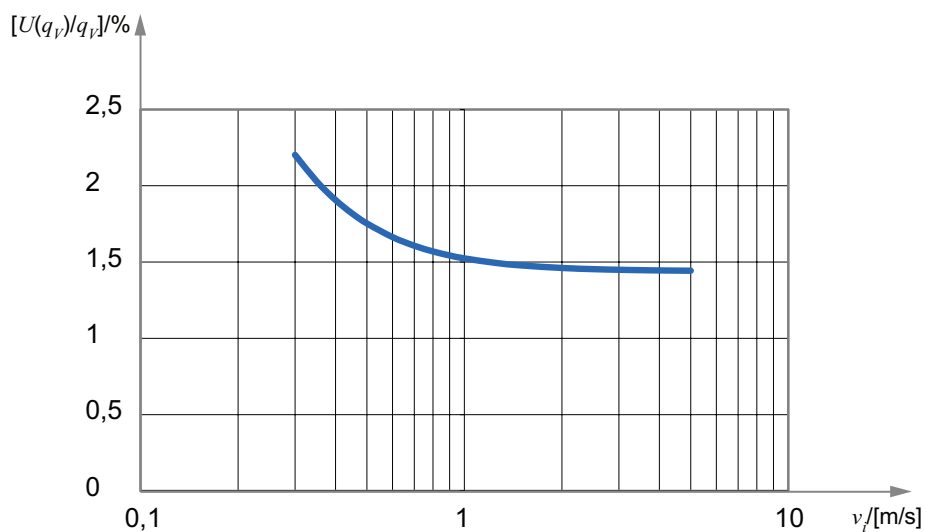

Key
 $U(\Delta q_v/q_v)$ expanded uncertainty in volume flowrate
 v_i path velocity

Figure C.2 — Expanded uncertainty versus path velocity for an example of a meter with externally mounted transducers

Annex D (informative)

Documents

D.1 General

In other clauses of this International Standard, documentation is required on accuracy, installation effects, electronics, ultrasonic transducers and zero flow verification. In addition to this documentation, the manufacturer shall provide all necessary data, certificates, and documentation for a correct configuration, set-up, and use of the particular meter for it to operate correctly. This includes a user's manual, pressure test certificates, material certificates, a measurement report on all geometrical parameters of the meter body, and certificates specifying the zero flow verification parameters used.

The manufacturer shall provide the following set of documents as a minimum:

- a) a description of the meter giving the technical characteristics and the principle of its operation;
- b) a perspective drawing or photograph of the meter;
- c) a nomenclature of parts with a description of constituent materials of such parts;
- d) an assembly drawing with identification of the component parts listed in the nomenclature;
- e) a dimensioned drawing;
- f) a drawing showing the location of verification marks and seals;
- g) a dimensioned drawing of metrologically important components;
- h) a drawing of the data plate or face plate and of the arrangements for inscriptions;
- i) a drawing of any auxiliary devices;
- j) instructions for installation, operation, and periodic maintenance;
- k) maintenance documentation including third party drawings for any field-repairable components;
- l) a description of the electronic signal processing unit, arrangement, and general description of operation;
- m) a description of the available output signals and any adjustment mechanisms;
- n) a list of electronic interfaces and user wiring termination points with their essential characteristics;
- o) a description of software functions and operating instructions;
- p) documentation that the design and construction comply with applicable safety codes and regulations;
- q) documentation that the performance of the meter meets the requirements of Clause 5;
- r) a field verification test procedure as described in Clause 11;
- s) a list of the documents submitted.

All documentation shall be dated.

D.2 After receipt of order

The manufacturer shall furnish meter outline drawings including overall flange face-to-face dimensions, inside diameter, maintenance space clearances, conduit connection points, and estimated mass.

The manufacturer shall provide a recommended list of spare parts.

The manufacturer shall also furnish meter-specific electrical drawings showing customer wiring termination points and associated electrical schematics for all circuit components back to the first isolating component, e.g. optical isolator, relay, and operational amplifier. This allows the designer to design the interfacing electronic circuits properly.

D.3 Before shipment

Prior to shipment of the meter, the manufacturer shall make the following available for the inspector's review: metallurgy reports, weld-inspection reports, pressure-test reports, final dimensional measurements and flow calibration certificates (where applicable).

Bibliography

- [1] ISO 5167-1:2003, *Measurement of fluid flow by means of pressure differential devices inserted in circular cross-section conduits running full — Part 1: General principles and requirements*
- [2] ISO/TR 7066-1:1997, *Assessment of uncertainty in calibration and use of flow measurement devices — Part 1: Linear calibration relationships*
- [3] ISO/TR 7871:1997,²⁾ *Cumulative sum charts — Guidance on quality control and data analyses using CUSUM techniques*
- [4] OIML D 11:2004, *General requirements for electronic measuring instruments*
- [5] AGA Report No. 9, *Measurement of gas by multipath ultrasonic meters*, Transmission Measurement Committee, 2nd edition. Arlington, VA: American Gas Association, 2007
- [6] API MPMS 5.8, *Measurement of liquid hydrocarbons by ultrasonic flow meters using transit time technology*. In: *API manual of petroleum measurement standards*
- [7] BROCA, O., ESCANDA, J., DELENNE, B. Influence of flow conditions on an ultrasonic flow meter. *Flomeko*, 2003
- [8] DE BOER, G., KURTH, M. Investigation regarding installation effects for small ultrasonic metering packages. *North Sea Flow Measurement Workshop*, 1999
- [9] BOKHORST, E. Impact of pulsation sources in pipe systems on multipath ultrasonic flow meters. *North Sea Flow Measurement Workshop*, 2000
- [10] BROWN, G. Velocity profile effects on multipath ultrasonic flow meters. *6th International Symposium on Fluid Flow Measurement*, 2006
- [11] CALOGIROU, A., BOEKHOVEN, J., HENKES, R.A.W.M. Effect of wall roughness changes on ultrasonic gas flow meters. *Flow Meas. Instrum.* 2001, **12**, pp. 219–229
- [12] COMMISSARIS, K.H., DE BOER, G. Realisation of compact metering runs with ultrasonic gas flow meters and reducing measurement uncertainty. *Flomeko*, 2003
- [13] COULL, J.C., BARTON, N.A. Investigation of the installation effects on ultrasonic flow meters and evaluation of computational fluid dynamics prediction methods. *North Sea Flow Measurement Workshop*, 2002
- [14] DANE, H.J., WILSACK, R. Upstream pipe wall roughness influence on ultrasonic flow measurement. *AGA Operations Conference*, 1999
- [15] DRENTHEM, J.G. *The use of the speed of sound as a verification tool*. Instromet International publication, 2000
- [16] DRENTHEM, J.G., KURTH, M., VAN KLOOSTER, J. A novel design of a 12 chords ultrasonic gas flow meter with extended diagnostic functions. *AGA Operations Conference*, 2007
- [17] FOLKESTAD, T., FLØLO, D., TUNHEIM, H., NESSE, Ø. Operating experience with two ultrasonic gas meters in series. *North Sea Flow Measurement Workshop*, 2003, Paper no 17
- [18] FURUICHI, N., SATO, H., TERAOKA, Y. Effect of surface roughness of pipe wall for transit time ultrasonic flowmeter. *6th International Symposium on Fluid Flow Measurement*, 2006
- [19] GERG PROJECT. Evaluation of flow conditioners — ultrasonic meters combinations. *North Sea Flow Measurement Workshop*, 2004
- [20] GRIMLEY, T.A. Performance testing of ultrasonic flow meters. *North Sea Flow Measurement Workshop*, 1997

2) Withdrawn.

- [21] HOGENDOORN, J., TAWACKOLIAN, K., VAN BRAKEL, P., VAN KLOOSTER, J., DRENTHE, J. High viscosity hydrocarbon flow measurement, a challenge for ultrasonic flow meters? *North Sea Flow Measurement Workshop*, 2009
- [22] KARNIK, U., GEERLINGS, J. The effect of steps and wall roughness on multipath ultrasonic meters. *5th International Symposium on Fluid Flow Measurement*, 2002
- [23] KEGEL, T.M. Uncertainty analysis of turbine and ultrasonic meter volume measurements. *AGA Operations Conference*, Orlando, Florida, 2003
- [24] MANTILLA, J., HANER, W. Process variable stability, data processing and installation end environmental influences during ultrasonic meter calibration. *6th International Symposium on Fluid Flow Measurement*, 2006
- [25] MOORE, P.I., BROWN, G.J., STIMPSON, B.P. Modelling of transit time ultrasonic flow meters in theoretical asymmetric flow. *Flomeko*, 2000
- [26] MOORE, P.I. Modelling of installation effects on transit time ultrasonic flow meters in circular pipes. PhD thesis, University of Strathclyde, 2000
- [27] MORRISON, G.L., TUNG, K. *Numerical simulation of the flow field downstream of 90 degree elbows and the simulated response of an ultrasonic flow meter*. Chicago, IL: Gas Research Institute, 2001. (Technical Report No. GRI-01/0090)
- [28] MORRISON, G.L. *Pipe wall roughness effect upon orifice and ultrasonic flow meters*. Chicago, IL: Gas Research Institute, 2001. (Technical Report No. GRI-01/0091.)
- [29] MORRISON, G.L., BRAR, P. *CFD evaluation of pipeline gas stratification at low flow due to temperature effects*. Chicago, IL: Gas Research Institute, 2004. (Topical Report GRI-04/0185.)
- [30] MORROW, T.B. *Line pressure and low-flow effects on ultrasonic gas flow meter performance*. Chicago, IL: Gas Research Institute, 2005. (Topical Report GRI-05/0133.)
- [31] RIEZEBOS, H.J. Whistling flow straighteners and their influence on US flow meter accuracy. *North Sea Flow Measurement Workshop*, 2000
- [32] SCHLICHTING, H., GERSTEN, K. *Boundary layer theory*, 8th edition. Berlin: Springer, 2000. 799 p.
- [33] SLOET, G.H. Bi-directional fiscal metering stations by means of ultrasonic meters. *North Sea Flow Measurement Workshop*, 1999
- [34] VERMEULEN, M.J.M., DE BOER, G., BUIJEN VAN WEELDEN, A., BOTTER, E., DIJKMANS, R. Coded multiple burst (CMB) signal processing applied to ultrasonic flow meters in applications with high noise levels. *North Sea Flow Measurement Workshop*, 2004
- [35] VOLKER, H., WEHMEIER, M., DIETZ, T., EHRLICH, A., DIETZEN, M. The use of an 8 path ultrasonic meter as a reference standard. *5th International South East Asia Hydrocarbon Flow Measurement Workshop*, 2005
- [36] WILSACK, R. Integrity of custody transfer measurement and ultrasonic technology. *CGA Measurement School*, 1996
- [37] ZANKER, K. The calibration, proving and validation of ultrasonic flow meters. *6th International Symposium on Fluid Flow Measurement* 2006
- [38] ISO 5168:2005, *Measurement of fluid flow — Procedures for the evaluation of uncertainties*
- [39] ISO 11631:1998, *Measurement of fluid flow — Methods of specifying flowmeter performance*
- [40] ISO/IEC 17025, *General requirements for the competence of testing and calibration laboratories*
- [41] ISO 17089-1:2010, *Measurement of fluid flow in closed conduits — Ultrasonic meters for gas — Part 1: Meters for custody transfer and allocation measurement*

- [42] ISO 80000-4:2006, *Quantities and units — Part 4: Mechanics*
- [43] ISO/IEC Guide 98-3:2008, *Uncertainty of measurement — Part 3: Guide to the expression of uncertainty in measurement (GUM:1995)*
- [44] ISO/IEC Guide 99:2007, *International vocabulary of metrology — Basic and general concepts and associated terms (VIM)*
- [45] SWAMEE, P.K.; JAIN, A.K. Explicit equations for pipe-flow problems. *J. Hydraulics Div. (ASCE)* 1976, **102**, pp. 657–664
- [46] HAACKE, A.C. Extended theory of the ultrasonic flowmeter. In: SZILVASSY, A., editor. *FLOMEKO '83*, 1983-09, Budapest

British Standards Institution (BSI)

BSI is the independent national body responsible for preparing British Standards and other standards-related publications, information and services. It presents the UK view on standards in Europe and at the international level.

BSI is incorporated by Royal Charter. British Standards and other standardisation products are published by BSI Standards Limited.

Revisions

British Standards and PASs are periodically updated by amendment or revision. Users of British Standards and PASs should make sure that they possess the latest amendments or editions.

It is the constant aim of BSI to improve the quality of our products and services. We would be grateful if anyone finding an inaccuracy or ambiguity while using British Standards would inform the Secretary of the technical committee responsible, the identity of which can be found on the inside front cover. Similar for PASs, please notify BSI Customer Services.

Tel: +44 (0)20 8996 9001 Fax: +44 (0)20 8996 7001

BSI offers BSI Subscribing Members an individual updating service called PLUS which ensures that subscribers automatically receive the latest editions of British Standards and PASs.

Tel: +44 (0)20 8996 7669 Fax: +44 (0)20 8996 7001

Email: plus@bsigroup.com

Buying standards

You may buy PDF and hard copy versions of standards directly using a credit card from the BSI Shop on the website www.bsigroup.com/shop. In addition all orders for BSI, international and foreign standards publications can be addressed to BSI Customer Services.

Tel: +44 (0)20 8996 9001 Fax: +44 (0)20 8996 7001

Email: orders@bsigroup.com

In response to orders for international standards, BSI will supply the British Standard implementation of the relevant international standard, unless otherwise requested.

Information on standards

BSI provides a wide range of information on national, European and international standards through its Knowledge Centre.

Tel: +44 (0)20 8996 7004 Fax: +44 (0)20 8996 7005

Email: knowledgecentre@bsigroup.com

BSI Subscribing Members are kept up to date with standards developments and receive substantial discounts on the purchase price of standards. For details of these and other benefits contact Membership Administration.

Tel: +44 (0)20 8996 7002 Fax: +44 (0)20 8996 7001

Email: membership@bsigroup.com

Information regarding online access to British Standards and PASs via British Standards Online can be found at www.bsigroup.com/BSOL

Further information about British Standards is available on the BSI website at www.bsi-group.com/standards

Copyright

All the data, software and documentation set out in all British Standards and other BSI publications are the property of and copyrighted by BSI, or some person or entity that own copyright in the information used (such as the international standardisation bodies) has formally licensed such information to BSI for commercial publication and use. Except as permitted under the Copyright, Designs and Patents Act 1988 no extract may be reproduced, stored in a retrieval system or transmitted in any form or by any means – electronic, photocopying, recording or otherwise – without prior written permission from BSI. This does not preclude the free use, in the course of implementing the standard, of necessary details such as symbols, and size, type or grade designations. If these details are to be used for any other purpose than implementation then the prior written permission of BSI must be obtained. Details and advice can be obtained from the Copyright & Licensing Department.

Tel: +44 (0)20 8996 7070

Email: copyright@bsigroup.com

BSI

389 Chiswick High Road London W4 4AL UK

Tel +44 (0)20 8996 9001

Fax +44 (0)20 8996 7001

www.bsigroup.com/standards