

Implants for surgery — Mechanical testing of implantable spinal devices — Fatigue test method for spinal implant assemblies using an anterior support

ICS 11.040.40

National foreword

This British Standard is the UK implementation of ISO 12189:2008.

The UK participation in its preparation was entrusted to Technical Committee CH/150/5, Osteosynthesis and spinal devices.

A list of organizations represented on this committee can be obtained on request to its secretary.

This publication does not purport to include all the necessary provisions of a contract. Users are responsible for its correct application.

Compliance with a British Standard cannot confer immunity from legal obligations.

This British Standard was published under the authority of the Standards Policy and Strategy Committee on 28 February 2009

© BSI 2009

ISBN 978 0 580 63685 1

Amendments/corrigenda issued since publication

Date	Comments

INTERNATIONAL STANDARD

ISO
12189

First edition
2008-05-01

Implants for surgery — Mechanical testing of implantable spinal devices — Fatigue test method for spinal implant assemblies using an anterior support

Implants chirurgicaux — Essais mécaniques des dispositifs spinaux implantables — Méthode d'essai de fatigue des ensembles d'implants spinaux utilisant un support antérieur



Reference number
ISO 12189:2008(E)

© ISO 2008

PDF disclaimer

This PDF file may contain embedded typefaces. In accordance with Adobe's licensing policy, this file may be printed or viewed but shall not be edited unless the typefaces which are embedded are licensed to and installed on the computer performing the editing. In downloading this file, parties accept therein the responsibility of not infringing Adobe's licensing policy. The ISO Central Secretariat accepts no liability in this area.

Adobe is a trademark of Adobe Systems Incorporated.

Details of the software products used to create this PDF file can be found in the General Info relative to the file; the PDF-creation parameters were optimized for printing. Every care has been taken to ensure that the file is suitable for use by ISO member bodies. In the unlikely event that a problem relating to it is found, please inform the Central Secretariat at the address given below.



COPYRIGHT PROTECTED DOCUMENT

© ISO 2008

All rights reserved. Unless otherwise specified, no part of this publication may be reproduced or utilized in any form or by any means, electronic or mechanical, including photocopying and microfilm, without permission in writing from either ISO at the address below or ISO's member body in the country of the requester.

ISO copyright office
Case postale 56 • CH-1211 Geneva 20
Tel. + 41 22 749 01 11
Fax + 41 22 749 09 47
E-mail copyright@iso.org
Web www.iso.org

Published in Switzerland

Contents

Page

Foreword.....	iv
Introduction	v
1 Scope	1
2 Normative references	1
3 Terms and definitions.....	1
4 Principle	2
5 Reagents and materials	3
5.1 Fluid test medium (optional).....	3
5.2 Test specimen	4
6 Apparatus	8
6.1 Testing machine.....	8
6.2 Means of mounting and enclosing the test specimen	8
6.3 Temperature control system (optional)	8
7 Procedure	8
8 Test report	9
9 Accuracy and bias	10
9.1 Accuracy.....	10
9.2 Bias.....	10
Bibliography	11

Foreword

ISO (the International Organization for Standardization) is a worldwide federation of national standards bodies (ISO member bodies). The work of preparing International Standards is normally carried out through ISO technical committees. Each member body interested in a subject for which a technical committee has been established has the right to be represented on that committee. International organizations, governmental and non-governmental, in liaison with ISO, also take part in the work. ISO collaborates closely with the International Electrotechnical Commission (IEC) on all matters of electrotechnical standardization.

International Standards are drafted in accordance with the rules given in the ISO/IEC Directives, Part 2.

The main task of technical committees is to prepare International Standards. Draft International Standards adopted by the technical committees are circulated to the member bodies for voting. Publication as an International Standard requires approval by at least 75 % of the member bodies casting a vote.

Attention is drawn to the possibility that some of the elements of this document may be the subject of patent rights. ISO shall not be held responsible for identifying any or all such patent rights.

ISO 12189 was prepared by Technical Committee ISO/TC 150, *Implants for surgery*, Subcommittee SC 5, *Osteosynthesis and spinal devices*.

Introduction

Different concepts of posterior spinal fusion devices such as “rigid” and “semi-rigid” or “dynamic” systems are available on the market. Some of these existing spinal implants are not indicated in major instability cases (“semi-rigid” or “dynamic” implants, hook- and wire-based fixation implants, artificial ligaments, etc.), because they have been designed to allow load-sharing with the anterior column. This document strongly emphasises the effects of the load-sharing phenomenon, largely described in the literature, as a very important feature regarding the load patterns to which the spinal implants are submitted.

As these different concepts result in different implant behaviour, a corpectomy configuration construct might not always be appropriate for testing, since total corpectomy without subsequent provision for anterior support occurs very seldom in clinical practice, and also because this kind of construct neglects the influence of anterior column support on implant loading. Moreover, some kinds of implant are often too flexible to be tested on their own or in a corpectomy configuration. This International Standard is intended to allow fatigue testing of flexible spinal implants and allow biomechanical fatigue testing of any kind of spinal implants, particularly semi-rigid and dynamic implants, regardless of their intrinsic rigidity. This document describes compression/flexion fatigue testing; additional mechanical tests, such as multi-directional testing (shear, torsion, lateral bending), might be required to assess clinical device safety.

For devices which are able to withstand loading in a corpectomy configuration, the test should be performed without anterior support in accordance with ASTM F1717 to demonstrate that, in a worst-case scenario, the device can support full load.

This International Standard is related to the methods for fatigue test of spinal implant assemblies (for fusion or motion preservation) with an anterior support.

www.bsigroup.com/standards

Implants for surgery — Mechanical testing of implantable spinal devices — Fatigue test method for spinal implant assemblies using an anterior support

1 Scope

This International Standard specifies methods for fatigue testing of spinal implant assemblies (for fusion or motion preservation) using an anterior support. It is intended to provide a basis for the assessment of intrinsic static and dynamic strength of spinal implants.

2 Normative references

The following referenced documents are indispensable for the application of this document. For dated references, only the edition cited applies. For undated references, the latest edition of the referenced document (including any amendments) applies.

ISO 10243, *Tools for pressing — Compression springs with rectangular section — Housing dimensions and colour coding*

ASTM F1717, *Standard Test Methods for Spinal Implant Constructs in a Vertebrectomy Model*

3 Terms and definitions

For the purposes of this document, the following terms and definitions apply.

3.1

active length of the longitudinal element

straight line distance between the centre of attachment of the superior anchor and the centre of attachment of the inferior anchor

3.2

model moment arm

perpendicular distance to the applied load between the insertion point of an anchor and the load application centre

3.3

failure

permanent deformation resulting from fracture; plastic deformation or loosening beyond the ultimate displacement that would render the spinal implant assembly ineffective or unable to adequately resist load

3.4

insertion point of an anchor

location where the anchor is attached to the segment model

3.5

intended spinal location

anatomic region of the spine intended for the application of the spinal implant assembly

NOTE Spinal implant assemblies are developed for specific spinal locations such as the anterior cervical spine or the posterior cervical, thoracolumbar, lumbar and lumbosacral spine.

3.6

maximum run-out load

maximum load that can be applied to a spinal implant assembly where all of the tested constructs have withstood 5 000 000 cycles without a failure

3.7

spinal implant assembly

complete spinal implant configuration as intended for surgical use

NOTE A spinal implant assembly will contain anchors, interconnections and longitudinal elements and can contain transverse elements.

3.8

spinal implant construct

complete spinal implant assembly attached to the appropriate test support

3.9

UHMWPE test block

component of the test apparatus for mounting the spinal implant assembly

NOTE 1 A specific design of UHMWPE test blocks is required for each intended spinal location and intended method of application. Figures 1, 2 and 3 describe the recommended designs for the test blocks (lumbar samples) and Figure 4 describes the recommended design for cervical samples; however, alternate designs can be used as long as equivalent performance is demonstrated.

NOTE 2 Spinal implant assemblies contain different types of anchors. Each type of anchor has an intended method of application to the spine.

4 Principle

The aim of this International Standard is to provide a fatigue test method that allows for testing of spinal devices that are not suited to corpectomy testing.

This protocol is based on the use of modified Ultra-High Molecular Weight Polyethylene (UHMWPE) test blocks (derived from those used in corpectomy or corporectomy testing) and springs (see Figure 1). This test support is composed of test blocks, made of UHMWPE representing vertebrae, and standardized springs representing the intervertebral disc stiffness. The springs are chosen from the "standardized" panel offered by ISO 10243. Then, fatigue tests in flexion compression are performed on the spinal implant construct (see Figure 1) in order to evaluate the spinal implant assembly (fatigue testing).

The insertion points shown in Figure 1 should be adhered to if possible. In situations where the design of the spinal implant assembly or the manufacturer's surgical instructions for installation dictate otherwise, the attachment points may deviate from these dimensions.

Dimensions in millimetres

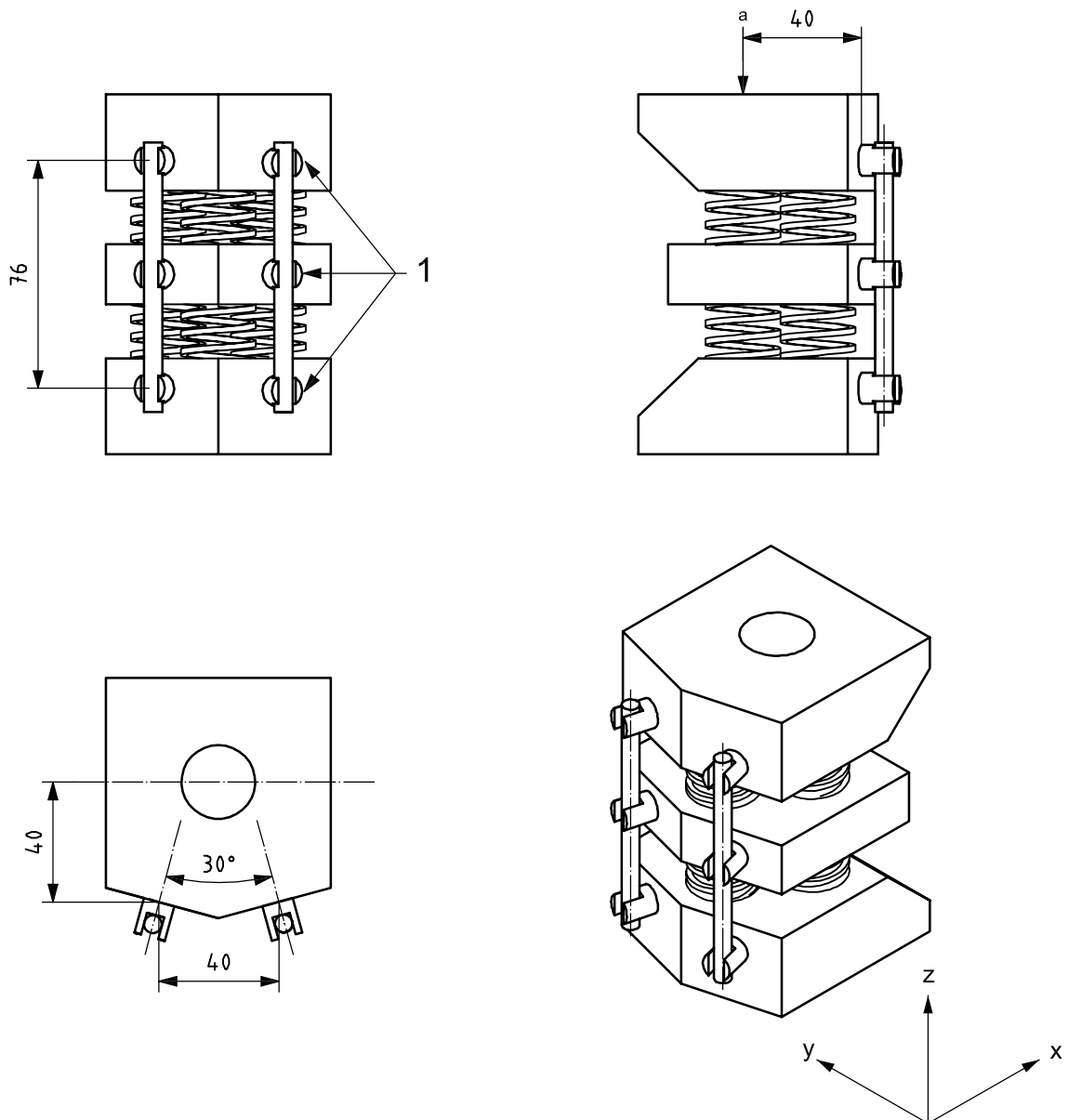

Key

- 1 insertion points
- a Load.

Figure 1 — A standard lumbar bilateral construct containing rods and screws

5 Reagents and materials

5.1 Fluid test medium (optional)

The use of a simulated body fluid, saline (9 g NaCl per 1 000 ml water), may be considered. In this case, it is necessary (before the fatigue test) to introduce the fluid test medium to completely immerse the contact surfaces of the test spinal implant construct. The temperature of the fluid test medium should be maintained at $37\text{ }^{\circ}\text{C} \pm 2\text{ }^{\circ}\text{C}$, and measurements during the tests should be taken at a location representative of the bulk temperature of the fluid.

NOTE In case of use of a simulated body fluid, and as ISO 10243 does not define the specific material properties of the springs, particular attention should be given to protecting the springs from corrosive agents, or to the use of springs (or alternative elastic elements, as long as the static and fatigue features are appropriate) made of corrosion-resistant materials.

5.2 Test specimen

The test support is implemented with UHMWPE test blocks and springs manufactured in accordance with ISO 10243 relative to housing dimensions and colour coding of compression springs with rectangular section, which define standardized stiffness of these springs. Springs are inserted between UHMWPE test blocks thanks to cylindrical reaming performed on each UHMWPE test block (see Figures 2 and 3). To preserve the spacing recommended in ASTM F1717 between UHMWPE test blocks (76 mm for lumbar implants and 35 mm for cervical implants), three blocks are considered for lumbar implants and two blocks for cervical implants. Alternative designs of the test support may be used as long as justification is provided. For example, a mono-segmental test set-up could be considered with a screw distance of 38 mm for lumbar implants.

The UHMWPE used to manufacture the tests blocks should have a tensile breaking strength equal to 40 MPa \pm 3 MPa.

To be consistent with the physiological behaviour of lumbar discs under compression loads, it is recommended that a combination of three springs in the same plane be used (see Figure 1). Each spring should have a spring stiffness of 375 N/mm with $L_0 = 25$ mm and $\phi_{\text{ext}} = 25$ mm.

NOTE 1 The stiffness under compression of the lumbar disc is roughly estimated in the literature to be between 700 N/mm and 2 500 N/mm (see References [1] to [4]).

NOTE 2 A spring with a stiffness of 375 N/mm that complies with ISO 10243 is colour-coded red.

For cervical implants (see Figure 4), use one spring with the same dimensions as that used for the lumbar disc but with a spring stiffness of either 147 N/mm or 100 N/mm.

NOTE 3 A spring with a stiffness of 147 N/mm that complies with ISO 10243 is colour-coded blue. A spring with a stiffness of 100 N/mm that complies with ISO 10243 is colour-coded green.

Alternative designs and springs (layout and stiffness) of the test support may be used as long as the static and fatigue features are appropriate. For example, other combinations of springs can be used to have a greater ratio of bending moment/compression force or for particular applications.

All components in the spinal implant assembly shall be previously unused parts only. Implants shall not be retested. The test support (UHMWPE test blocks and springs) shall be used for one test only. Then, label and maintain the tests constructs according to good laboratory practice, do not disassemble the test construct after testing unless disassembly is necessary to evaluate failure surface, interconnections, corrosion or loosening surfaces. Photograph the construct prior to disassembly.

Dimensions in millimetres

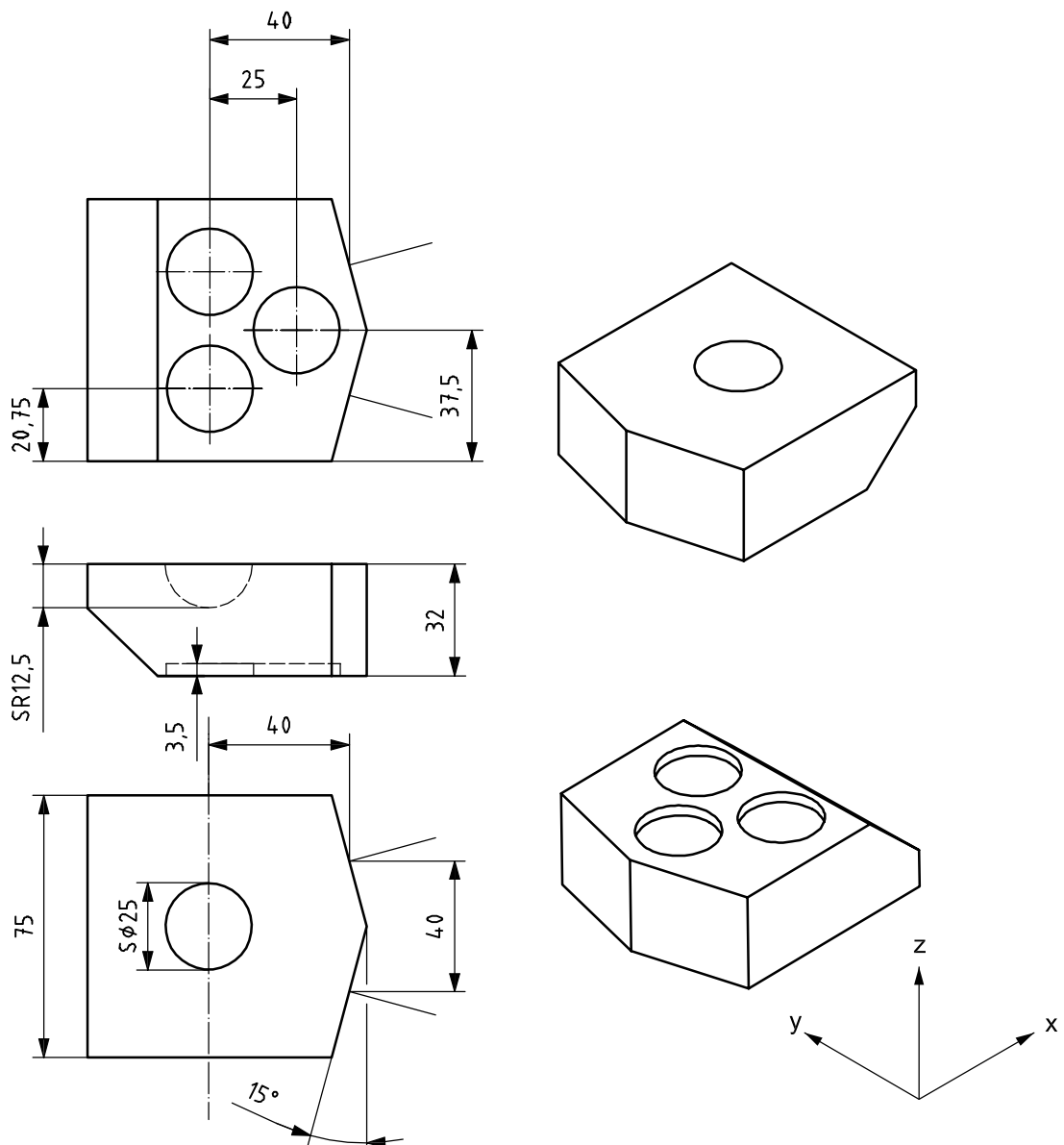

Figure 2 — Lumbar bilateral UHMWPE test block for screws or bolts

Dimensions in millimetres

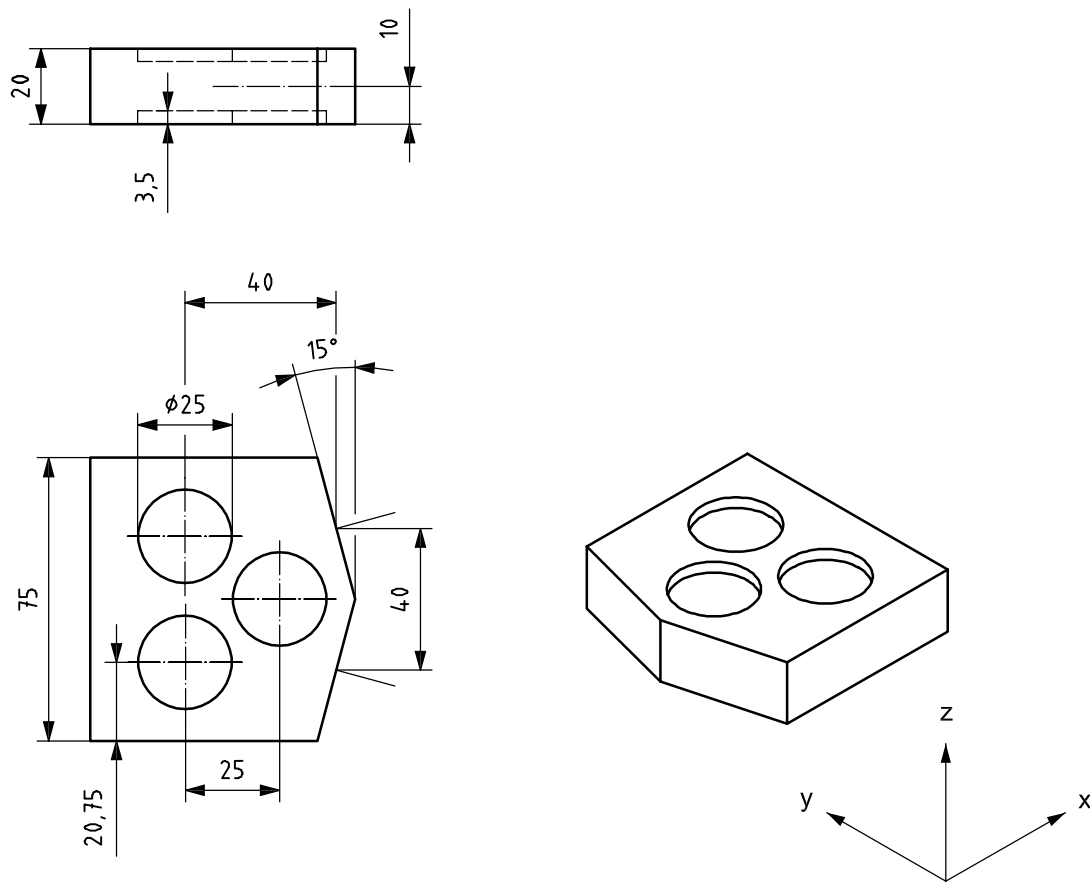
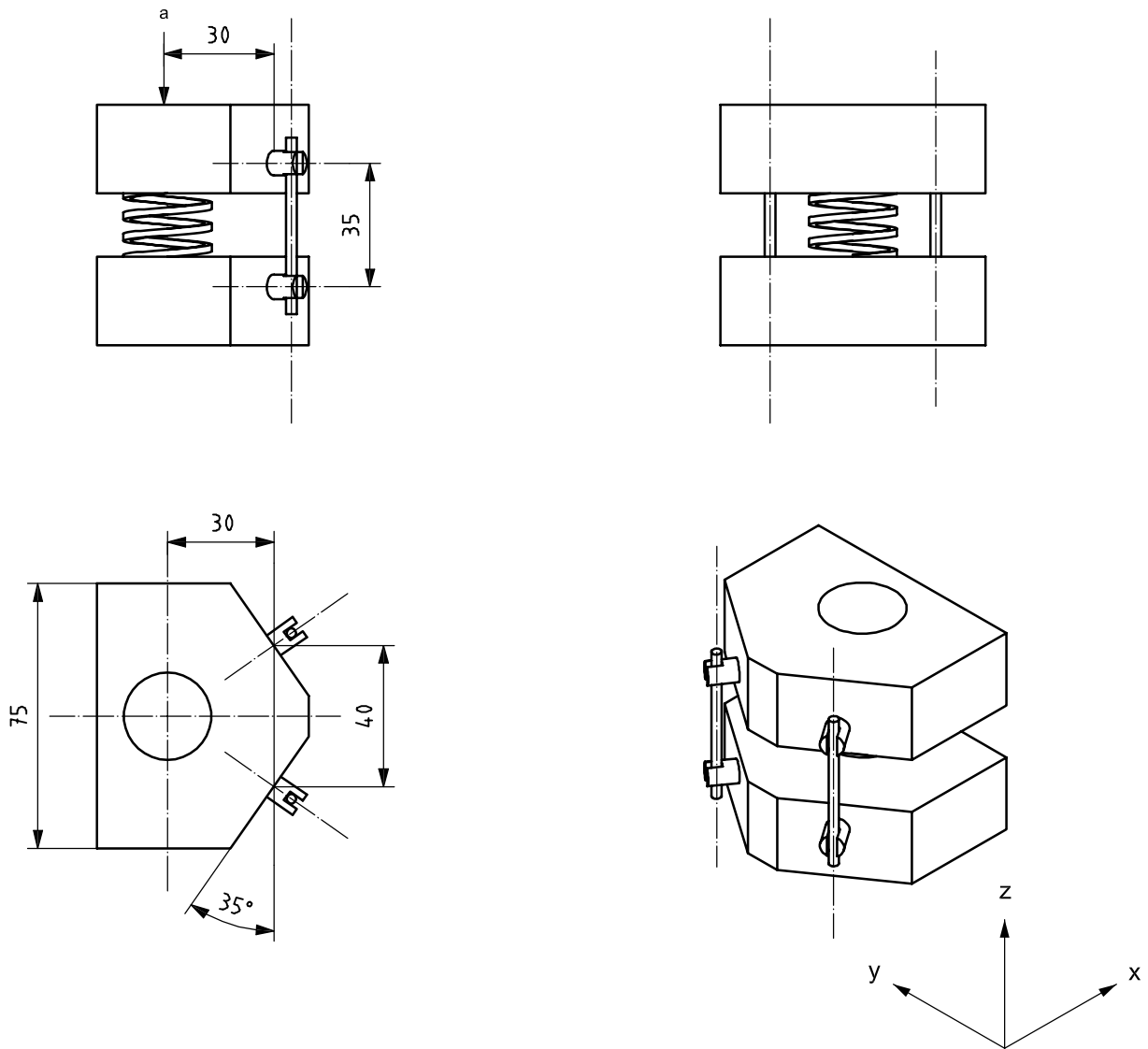

Figure 3 — Lumbar bilateral UHMWPE intermediary test block for screws or bolts

Dimensions in millimetres



a Load.

Figure 4 — Cervical bilateral construct and test block for screws or bolts

6 Apparatus

6.1 Testing machine

The testing machine shall be capable of producing the loads specified in Table 1, in association with the corresponding displacements, operating at a frequency of $5 \text{ Hz} \pm 0,1 \text{ Hz}$.

Table 1 — Load parameters of the testing machine

Implant	Load kN	Tolerance N
Lumbar	2,0 maximum	± 60
	0,6 minimum	± 60
Cervical	0,15 maximum	$\pm 4,5$
	0,05 minimum	$\pm 4,5$

The testing machine shall be capable of maintaining $\pm 1 \%$ of the cycle time for phasing.

6.2 Means of mounting and enclosing the test specimen

The testing machine shall have appropriate attachment methods (ball and socket system) to enclose the spinal implant construct.

6.3 Temperature control system (optional)

When employed, the temperature control system shall be capable of maintaining the temperature of the fluid test medium at $37 \text{ °C} \pm 2 \text{ °C}$ (see 5.1).

7 Procedure

7.1 Select the appropriate test support (intended spinal location and type of anchor). For hooks, cables and wires, the UHMWPE test blocks shall be modified in the same way as the blocks for corporectomy testing (see ASTM F1717).

7.2 Assemble and maintain blocks and springs together with a little preload (recommended: 1 mm compression for springs), then install the anchors according to the manufacturer's instructions. Complete the spinal implant assembly by applying all tightening, crimping or locking mechanisms as specified by the manufacturer.

7.3 Mount the spinal implant construct in the testing machine with an appropriate attachment system (ball and socket system).

7.4 If a fluid test medium is used, it shall completely immerse the spinal implant construct. Maintain the temperature of the fluid test medium at $37 \text{ °C} \pm 2 \text{ °C}$, taking the measurement at a location representative of the bulk temperature of the fluid. Determine the pH value (optional). During testing, replace the fluid lost by evaporation, at least daily.

7.5 Start the testing machine and adjust it so that the specified loads (in Table 1) are applied to the test specimen. The fatigue test applies a sinusoidal load to the spinal implant construct. The loading should be maintained via a constant sinusoidal load amplitude control. The maximum cycle rate is 5 Hz for the fatigue test (a lower cycle rate is recommended).

NOTE 1 Hz corresponds to 100 % of the cycle within one second.

7.6 Evaluate specimens at the initial fatigue loads. Continue fatigue testing of specimens with upper loads until failure of the spinal implant construct occurs. Establish the maximum run-out load. The suggested initial fatigue maximum loads should be 2 000 N, to be consistent with the physiological compression loads on lumbar discs roughly estimated in the literature (see References [5] to [7]).

A semi-log fatigue curve of the load versus number of cycles at failure shall be plotted.

7.7 Continue the test until one of the following occurs.

a) Completion of 5 000 000 cycles.

NOTE Upon request of the submitter of the specimen, the test can be conducted beyond this limit.

b) Failure or run-out of the spinal implant construct (functional or user-defined failure of the implant).

c) Failure of the testing machine to maintain the force and displacement parameters within the tolerances.

7.8 Note the initial and secondary failures, modes of failure and deformations of components prior to removing the spinal implant construct from the testing machine. Evaluate all surface changes.

7.9 Remove the spinal implant construct from the testing machine.

8 Test report

8.1 The test report shall:

a) include reference to this International Standard, i.e. ISO 12189:2008;

b) specify the spinal implant components, the spinal implant assembly, the intended spinal location and the numbers of specimens tested;

c) describe all relevant information about the components including name, lot number, manufacturer, material, part number, etc.;

d) include any specific information necessary to produce the assembly;

e) specify the spring length, the stiffness and spring constants for all springs;

f) describe all relevant information about the springs including reference, lot number, manufacturer, etc.;

g) include any specific information necessary to produce the assembly, including the preload and the tightening torque;

h) include an illustration of the exact loading configurations and describe the similarities and differences to relevant figures contained in this International Standard;

i) report the active length of the longitudinal element;

j) report the model moment arm and the distance in the X direction between the centreline of the longitudinal element and the insertion point of the anchors on the spine segment model;

k) note any deviations from the recommended test procedure;

l) state the rate of loading.

8.2 A report of the dynamic mechanical testing shall include the following details.

State the final sample sizes and load versus number of cycles at failure for all fatigue tests. State the load levels for the specimens enduring 5 000 000 cycles and the maximum run-out load.

Report all initial and secondary failures. Modes of failure and deformations of components for the spinal implant assembly and the testing machine shall also be reported. Fatigue failures should include a description of the failure initiation site, propagation zone and ultimate failure zone. Describe all surface changes, any fretting of interfaces or loosening of interconnections. Include pictures of failure surfaces and surface texturing from fretting.

Plot a semi-log fatigue curve of the compression load, compression bending load or compression bending moment versus number of cycles at failure. Indicate specimens which have not failed before 5 000 000 cycles.

Report a regression analysis of the compression load and compression bending load versus number of cycles for failed constructs only.

9 Accuracy and bias

9.1 Accuracy

It is not practical to specify the accuracy of the procedure in this International Standard because of the wide variance in design of the components to be tested.

9.2 Bias

No statement can be made as to bias in this International Standard since no acceptable reference values are available, nor can they be obtained because of the destructive nature of the test.

Bibliography

- [1] WHITE, A.A. and PANJABI, M.M., *Clinical biomechanics of the spine*, Lippincot, Philadelphia, 1990
- [2] BROWN, T., HANSEN, R.J. and YORRA, A.J., *Some mechanical tests on lumbosacral spine with particular reference to the intervertebral discs*, J. Bone Joint Surg., **39A**, pp.1135-63, 1957
- [3] MCGLASHEN, K.M., MILLER, J.A., SCHULTZ, A.B. and ANDERSSON, G.B., *Load displacement behavior of the human lumbo-sacral joint*, J. Orthop. Res., **5** (4), pp. 488-96, 1987
- [4] SHEA, M., et al., *A comparison of the effects of automated percutaneous diskectomy and conventional diskectomy on intradiscal pressure, disk geometry, and stiffness*, J. Spinal Disord., **7**(4), pp. 317-25, 1994
- [5] NACHEMSON, A.L., *Disc pressure measurements*. Spine, **6**(1), pp.93-7, 1981
- [6] NACHEMSON, A.L., *The load on lumbar discs in different positions of the body*, Clinical Orthopaedics, **45**, pp.107-22, 1966
- [7] WILKE, H.J., NEEF, P., CLIME, M., HOOGLAND, T. and CLAES, L.E., *New in vivo measurements of pressures in the intervertebral disc in daily life*. Spine, **24**(8), pp.755-62, 1999

www.bsi.org.uk

ICS 11.040.40

Price based on 11 pages

BSI - British Standards Institution

BSI is the independent national body responsible for preparing British Standards. It presents the UK view on standards in Europe and at the international level. It is incorporated by Royal Charter.

Revisions

British Standards are updated by amendment or revision. Users of British Standards should make sure that they possess the latest amendments or editions.

It is the constant aim of BSI to improve the quality of our products and services. We would be grateful if anyone finding an inaccuracy or ambiguity while using this British Standard would inform the Secretary of the technical committee responsible, the identity of which can be found on the inside front cover. Tel: +44 (0)20 8996 9000. Fax: +44 (0)20 8996 7400.

BSI offers members an individual updating service called PLUS which ensures that subscribers automatically receive the latest editions of standards.

Buying standards

Orders for all BSI, international and foreign standards publications should be addressed to Customer Services. Tel: +44 (0)20 8996 9001. Fax: +44 (0)20 8996 7001 Email: orders@bsigroup.com You may also buy directly using a debit/credit card from the BSI Shop on the Website <http://www.bsigroup.com/shop>

In response to orders for international standards, it is BSI policy to supply the BSI implementation of those that have been published as British Standards, unless otherwise requested.

Information on standards

BSI provides a wide range of information on national, European and international standards through its Library and its Technical Help to Exporters Service. Various BSI electronic information services are also available which give details on all its products and services. Contact Information Centre. Tel: +44 (0)20 8996 7111 Fax: +44 (0)20 8996 7048 Email: info@bsigroup.com

Subscribing members of BSI are kept up to date with standards developments and receive substantial discounts on the purchase price of standards. For details of these and other benefits contact Membership Administration. Tel: +44 (0)20 8996 7002 Fax: +44 (0)20 8996 7001 Email: membership@bsigroup.com

Information regarding online access to British Standards via British Standards Online can be found at <http://www.bsigroup.com/BSOL>

Further information about BSI is available on the BSI website at <http://www.bsigroup.com>

Copyright

Copyright subsists in all BSI publications. BSI also holds the copyright, in the UK, of the publications of the international standardization bodies. Except as permitted under the Copyright, Designs and Patents Act 1988 no extract may be reproduced, stored in a retrieval system or transmitted in any form or by any means – electronic, photocopying, recording or otherwise – without prior written permission from BSI.

This does not preclude the free use, in the course of implementing the standard, of necessary details such as symbols, and size, type or grade designations. If these details are to be used for any other purpose than implementation then the prior written permission of BSI must be obtained.

Details and advice can be obtained from the Copyright and Licensing Manager. Tel: +44 (0)20 8996 7070 Email: copyright@bsigroup.com