

BS ISO 12183:2016



BSI Standards Publication

# Nuclear fuel technology — Controlled-potential coulometric assay of plutonium

**National foreword**

This British Standard is the UK implementation of ISO 12183:2016.

The UK participation in its preparation was entrusted to Technical Committee NCE/9, Nuclear fuel cycle technology.

A list of organizations represented on this committee can be obtained on request to its secretary.

This publication does not purport to include all the necessary provisions of a contract. Users are responsible for its correct application.

© The British Standards Institution 2016. Published by BSI Standards Limited 2016

ISBN 978 0 580 87811 4

ICS 27.120.30

**Compliance with a British Standard cannot confer immunity from legal obligations.**

This British Standard was published under the authority of the Standards Policy and Strategy Committee on 31 August 2016.

**Amendments issued since publication**

Date	Text affected
------	---------------

---

---

---

**Nuclear fuel technology — Controlled-  
potential coulometric assay of  
plutonium**

*Technologie du combustible nucléaire — Dosage du plutonium par  
coulométrie à potentiel imposé*



**COPYRIGHT PROTECTED DOCUMENT**

© ISO 2016, Published in Switzerland

All rights reserved. Unless otherwise specified, no part of this publication may be reproduced or utilized otherwise in any form or by any means, electronic or mechanical, including photocopying, or posting on the internet or an intranet, without prior written permission. Permission can be requested from either ISO at the address below or ISO's member body in the country of the requester.

ISO copyright office  
Ch. de Blandonnet 8 • CP 401  
CH-1214 Vernier, Geneva, Switzerland  
Tel. +41 22 749 01 11  
Fax +41 22 749 09 47  
copyright@iso.org  
www.iso.org

# Contents

Page

<b>Foreword</b> .....	<b>iv</b>
<b>1 Scope</b> .....	<b>1</b>
<b>2 Normative references</b> .....	<b>1</b>
<b>3 Terms and definitions</b> .....	<b>1</b>
<b>4 Principle</b> .....	<b>1</b>
<b>5 Reagents</b> .....	<b>2</b>
<b>6 Apparatus</b> .....	<b>2</b>
<b>7 Procedure</b> .....	<b>8</b>
7.1 Plutonium determination.....	8
7.1.1 Weighing the test sample, with an uncertainty of $\pm 0,01$ %, $K = 1$ .....	8
7.1.2 Preparation of the test sample.....	9
7.1.3 Electrode pre-treatment.....	9
7.1.4 Electrical calibration of the current integration system.....	10
7.1.5 Formal potential determination.....	11
7.1.6 Coulometric blank determination.....	12
7.1.7 Plutonium measurement.....	13
7.2 Analysis of subsequent test samples.....	13
<b>8 Expression of results</b> .....	<b>14</b>
8.1 Calculation of the electrical calibration factor.....	14
8.2 Calculation of the blank.....	14
8.3 Fraction of electrolysed plutonium.....	15
8.4 Plutonium content.....	16
8.5 Quality control.....	16
<b>9 Characteristics of the method</b> .....	<b>16</b>
9.1 Repeatability.....	16
9.2 Confidence interval.....	17
9.3 Analysis time.....	17
<b>10 Interferences</b> .....	<b>17</b>
<b>11 Procedure variations and optimization</b> .....	<b>21</b>
11.1 Accountability measurements and reference material preparation.....	21
11.2 Process control measurements.....	21
11.3 Measurement cell design.....	21
11.4 Electrolyte and electrode options.....	22
11.5 Test sample size.....	22
11.6 Background current corrections.....	22
11.7 Correction for iron.....	23
11.8 Control-potential adjustment.....	24
11.9 Calibration methodologies.....	24
<b>Annex A (normative) Purification by anion-exchange separation</b> .....	<b>25</b>
<b>Annex B (normative) Determination of formal potential, <math>E_0</math></b> .....	<b>27</b>
<b>Bibliography</b> .....	<b>28</b>

## Foreword

ISO (the International Organization for Standardization) is a worldwide federation of national standards bodies (ISO member bodies). The work of preparing International Standards is normally carried out through ISO technical committees. Each member body interested in a subject for which a technical committee has been established has the right to be represented on that committee. International organizations, governmental and non-governmental, in liaison with ISO, also take part in the work. ISO collaborates closely with the International Electrotechnical Commission (IEC) on all matters of electrotechnical standardization.

The procedures used to develop this document and those intended for its further maintenance are described in the ISO/IEC Directives, Part 1. In particular, the different approval criteria needed for the different types of ISO documents should be noted. This document was drafted in accordance with the editorial rules of the ISO/IEC Directives, Part 2 (see [www.iso.org/directives](http://www.iso.org/directives)).

Attention is drawn to the possibility that some of the elements of this document may be the subject of patent rights. ISO shall not be held responsible for identifying any or all such patent rights. Details of any patent rights identified during the development of the document will be in the Introduction and/or on the ISO list of patent declarations received (see [www.iso.org/patents](http://www.iso.org/patents)).

Any trade name used in this document is information given for the convenience of users and does not constitute an endorsement.

For an explanation on the meaning of ISO specific terms and expressions related to conformity assessment, as well as information about ISO's adherence to the World Trade Organization (WTO) principles in the Technical Barriers to Trade (TBT) see the following URL: [www.iso.org/iso/foreword.html](http://www.iso.org/iso/foreword.html).

The committee responsible for this document is Technical Committee ISO/TC 85, *Nuclear energy, nuclear technologies, and radiological protection*, Subcommittee SC 5, *Nuclear fuel cycle*.

This third edition cancels and replaces the second edition (ISO 12183:2005), which has been technically revised.

# Nuclear fuel technology — Controlled-potential coulometric assay of plutonium

## 1 Scope

This document describes an analytical method for the electrochemical assay of pure plutonium nitrate solutions of nuclear grade, with a total uncertainty not exceeding  $\pm 0,2$  % at the confidence level of 0,95 for a single determination (coverage factor,  $K = 2$ ). The method is suitable for aqueous solutions containing more than 0,5 g/L plutonium and test samples containing between 4 mg and 15 mg of plutonium. Application of this technique to solutions containing less than 0,5 g/L and test samples containing less than 4 mg of plutonium requires experimental demonstration by the user that applicable data quality objectives will be met.

For some applications, purification of test samples by anion exchange is required before measurement to remove interfering substances when present in significant amounts. Refer to [Clause 10](#) for a discussion of interferences and corrective actions. Purification is also appropriate in situations where the purity of the test sample is unknown or when it may fluctuate unpredictably in a manufacturing process.

[Clause 11](#) discusses the changes in application of the method and methodology that can be applied and important considerations when selecting measurement parameters, while still remaining within the intended scope of this document.

## 2 Normative references

There are no normative references in this document.

## 3 Terms and definitions

No terms and definitions are listed in this document.

ISO and IEC maintain terminological databases for use in standardization at the following addresses:

- IEC Electropedia: available at <http://www.electropedia.org/>
- ISO Online browsing platform: available at <http://www.iso.org/obp>

## 4 Principle

The key steps and their purposes are outlined below:

- test samples are prepared by weighing and then fuming to dryness with sulphuric acid to achieve a consistent and stable anhydrous plutonium sulphate salt that is free from chloride, fluoride, nitrate, nitrite, hydroxylamine, and volatile organic compounds;
- if needed to remove interferences, dissolve test samples and purify by anion exchange, then fume the eluted plutonium solution in the presence of sulphuric acid to obtain the dry plutonium sulphate chemical form;
- measure a blank of the nitric acid supporting electrolyte and calculate the background current correction applicable to the electrolysis of the test sample from charging, faradaic, and residual current<sup>[1]</sup>;
- dissolve the dried test sample in the previously measured supporting electrolyte (the blank);

- reduce the test sample at a controlled potential that electrolyses the plutonium to greater than 99,8 % Pu<sup>3+</sup> and measure the equilibrium solution potential at the end of this step by control-potential adjustment[2];
- oxidize the test sample at a controlled potential that electrolyses the plutonium to greater than 99,8 % Pu<sup>4+</sup> and measure the equilibrium solution potential at the end of this electrolysis by control-potential adjustment;
- correct the result for the background current and the fraction of plutonium not electrolysed;
- calibrate the coulometer using traceable electrical standards and Ohm's Law;
- use the measured value of the coulometer calibration factor and the Faraday constant to convert the coulombs of integrated current from the electrolyses to moles of plutonium;
- use traceable quality-control plutonium standards to demonstrate independently the performance of the measurement system;
- periodically measure the formal potential of the plutonium couple,  $E_0$ , which is user-specific based on the cell design, connections, reference electrode type, and the acid-type and molarity of the supporting electrolyte.

These steps ensure that representative, reproducible, and stable test samples are prepared for measurement. The test samples are measured using a protocol that is based upon first principles and is consistent with a traceable, electrical calibration of the coulometer. Additional details are provided in [Clauses 10](#) and [11](#).

## 5 Reagents

Use only analytical grade reagents.

All aqueous solutions shall be prepared with double-distilled or distilled, demineralized water with a resistivity greater than 10 M $\Omega$ ·cm, i.e. ISO 3696 Grade 1 purified water.

### 5.1 Nitric acid solution, $c(\text{HNO}_3) = 0,9 \text{ mol/L}$ .

NOTE Refer to [11.4](#) for other electrolyte options.

### 5.2 Amidosulphuric acid solution, $c(\text{NH}_2\text{HSO}_3) = 1,5 \text{ mol/L}$ .

### 5.3 Sulphuric acid solution, $c(\text{H}_2\text{SO}_4) = 3 \text{ mol/L}$ .

NOTE Molarity is not a critical parameter for sulphuric acid used to fume plutonium test samples, provided the concentration of the reagent is well above the level where colloidal plutonium complexes form.

### 5.4 Pure argon or nitrogen, ( $\text{O}_2$ content lower than 10 ppm).

### 5.5 Pure air, free of organic contaminants.

## 6 Apparatus

Usual laboratory equipment found in a medium-activity radiochemical laboratory suitable for work with plutonium shall be used.

**6.1 Analytical balance**, installed in radiological containment unit and must be capable of weighing 1 g mass, with an uncertainty of  $\pm 0,1 \text{ mg}$  (coverage factor,  $K = 1$ ). This represents a relative uncertainty of 0,01 %.



- Weighing less than 1 g will increase the relative uncertainty to  $>0,01$  %, in an inversely proportional manner.
- If the uncertainty of the balance, as installed, does not meet the  $\pm 0,01$  mg criterion, then correspondingly larger test samples are required.

**6.2 Weighing burette**, glass or plastic, the material selection is not critical provided it maintains a stable mass (tare weight) and static charge is controlled as described in [7.1.1](#).

**6.3 Equipment for test sample evaporation in the coulometric cell**, comprising of an overhead radiant heater or hot-plate with controls to adjust temperature. Design requirements and optional features for effective evaporation and fuming include:

- providing settings that allow both rapid and well-controlled rate of initial evaporation, followed by fuming the remaining sulphuric acid solution to dryness at a higher temperature;
- preventing mechanical loss of the test sample solution from boiling and/or spattering;
- preventing contamination by extraneous chemicals, such as those which may be used to neutralize acid vapours;
- heating of the coulometer cell wall to optimize fuming and minimize refluxing of sulphuric acid by placing the cell inside an optional aluminium tube with an inner diameter that is 1 mm to 3 mm larger than the outer diameter of the cell and a height that is 1 mm to 5 mm shorter than the cell may be placed around the cell during the fuming step to heat the walls of the cell;

NOTE An aluminium block with holes bored to a similar specification for inserting the cell may be used instead of the aluminium tubes.

- addition of an optional air supply with the delivery tube directed towards the surface of the liquid to optimize the evaporation rate and disperse the acid fumes;
- addition of an optional vapour capture and local neutralization to control acid fumes, depending upon facility design and ventilation system requirements.

See [Figure 1](#).

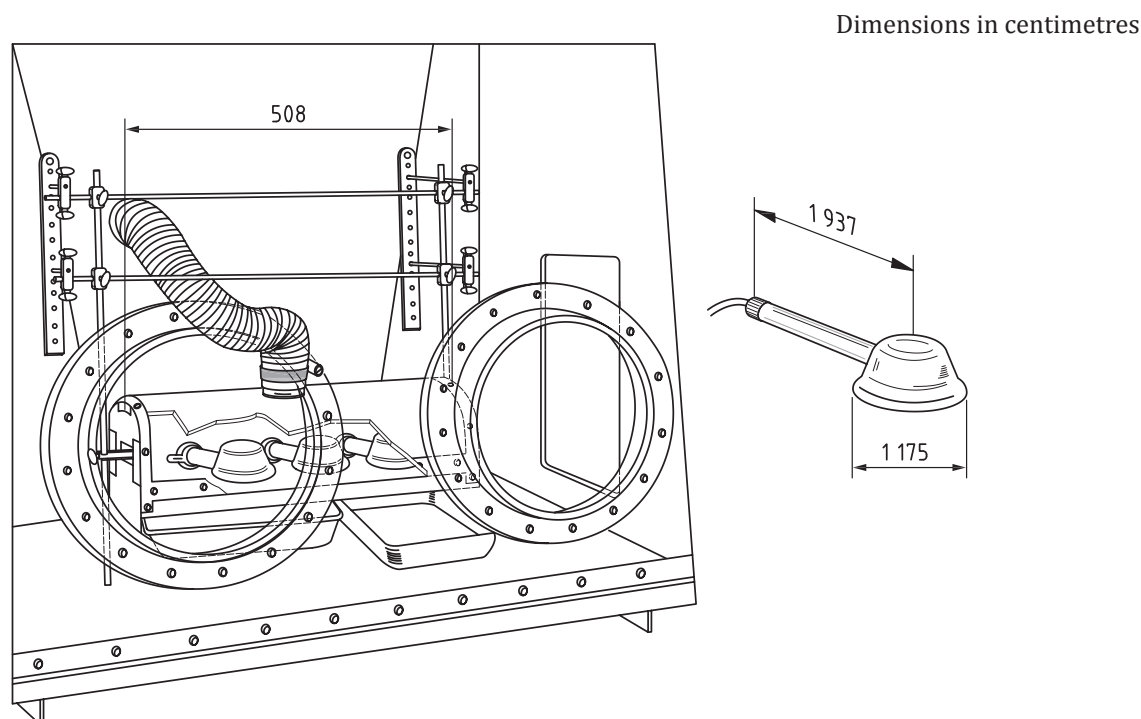

Figure 1 — Sample evaporation system

#### 6.4 Controlled-potential coulometer.

See [Figure 2](#).

##### 6.4.1 Coulometer cell assembly, comprising the following:

- a stirrer motor with a rotation frequency of at least  $1\,000\text{ min}^{-1}$ ;

NOTE 1 Adjustable-speed motors allow optimizing rotation rates for individual cell designs. Stirrer motors powered by isolated DC power supplies are desirable to prevent electrical noise from being superimposed on the blank and test sample electrolysis current signals sent to the integrator.

- a cylindrical or tapered glass coulometric cell of capacity 50 mL, or less, with an O-ring seal and a tight-fitting lid with openings to insert the following internal equipment:
  - an inlet tube for humidified, inert gas to displace dissolved and atmospheric oxygen from the solution and the electrolysis cell, respectively;
  - a stirrer with blade and shaft made from chemically inert materials [e.g. polytetrafluoroethylene (PTFE)], and designed to prevent splashing; the shaft of the stirrer is typically located in the centre of the cell and connected directly to the stirrer motor;
  - a working electrode made of gold (e.g. 99,99 %) and consisting of a gold wire welded or machined to a cylindrical gold wire frame, nominally 15 mm high and 20 mm in diameter, around which is welded or machined a very fine gold mesh, which is typically several layers (e.g. four layers);

NOTE 2 Refer to [11.4](#) for other working electrode options.

- a glass tube plugged at the bottom end with a sintered-glass disc (typical dimensions of 2,5-mm thick and pore size  $<0,01\ \mu\text{m}$ ), the tube filled with nitric acid ([5.1](#)) and the tip of the sintered-glass end positioned within the ring of the working electrode;
- a reference electrode, saturated calomel electrode (SCE), or other reference electrodes as described in [11.3](#), is inserted into the glass tube;

- another glass tube, similar to the first one, also filled with nitric acid (5.1), and the tip of the sintered-glass end positioned within the ring of the working electrode;
- an auxiliary electrode consisting of a platinum wire, 0,5 mm to 3,0 mm in diameter, is inserted into the second glass tube;

NOTE 3 The platinum wire may be coiled to increase the surface area submerged in the supporting electrolyte, as illustrated in Figure 2.

- a gas washer bottle, filled with reagent water as described in Clause 5, to humidify the inert gas before it is introduced into the coulometer cell assembly.

The diameter of the glass tube and sintered-glass disc containing the auxiliary electrode may be larger than that of the glass tube and sintered-glass disc containing the reference electrode. The flow rate of the solution through both glass discs shall be less than 0,05 mL/h.

- a) A thermocouple or resistance thermometer installed in the coulometer cell assembly for measuring the temperature of the test sample solution during the measurement process is an optional feature. The solution temperature should be measured either during the oxidation of the test sample or immediately following the analysis. An uncertainty goal for the temperature measurement is  $\pm 0,2$  °C ( $K = 1$ ).
  - If it is not possible to insert a temperature sensor into the electrolysis cell or not desirable to measure the temperature of the test sample solution immediately after the electrolysis is completed, then estimate the solution temperature from the ambient air temperature or the reagent temperature. Note that the purge gas is cooled by expansion causing the solution temperature to decrease relative to the ambient temperature; the extent of this decrease is a function of the inert-gas flow rate and the cell design. The measured air or reagent temperature value must be corrected for this cooling effect. A higher uncertainty of  $\pm 1$  °C,  $K = 1$ , is expected in the calculated solution temperature.
- b) For optimum potential control, position the sintered-glass discs of the reference and auxiliary electrodes glass tubes to meet the following requirements:
  - the closest distance from the reference electrode sintered-glass disc to the working electrode is 2 mm or less;
  - the distance between the two sintered-glass discs containing the auxiliary and reference electrodes is less than the distance between the auxiliary electrode disc and the nearest point on the working electrode.
- c) The hole through which the stirrer shaft is inserted serves as the primary escape vent for the inert gas. Except for this hole, all other insertions are tight fitting. The inert-gas flow rate must be sufficiently high to quickly remove oxygen from the supporting electrolyte and the test sample solution. Furthermore, it must prevent leakage of air into the cell assembly during the electrolysis. A practical guide for adjusting the flow rate is to direct all or part of the inert gas supply toward the solution, such that a 2 mm to 4 mm dimple is formed on the surface without causing the solution to splash.
  - Cell assemblies with an optimized design, an adequate inert-gas flow rate, and a tight fit, will remove oxygen in 5 min or less. The time required to remove oxygen from the solution should be established by users based on testing of their cell assembly under routine conditions.

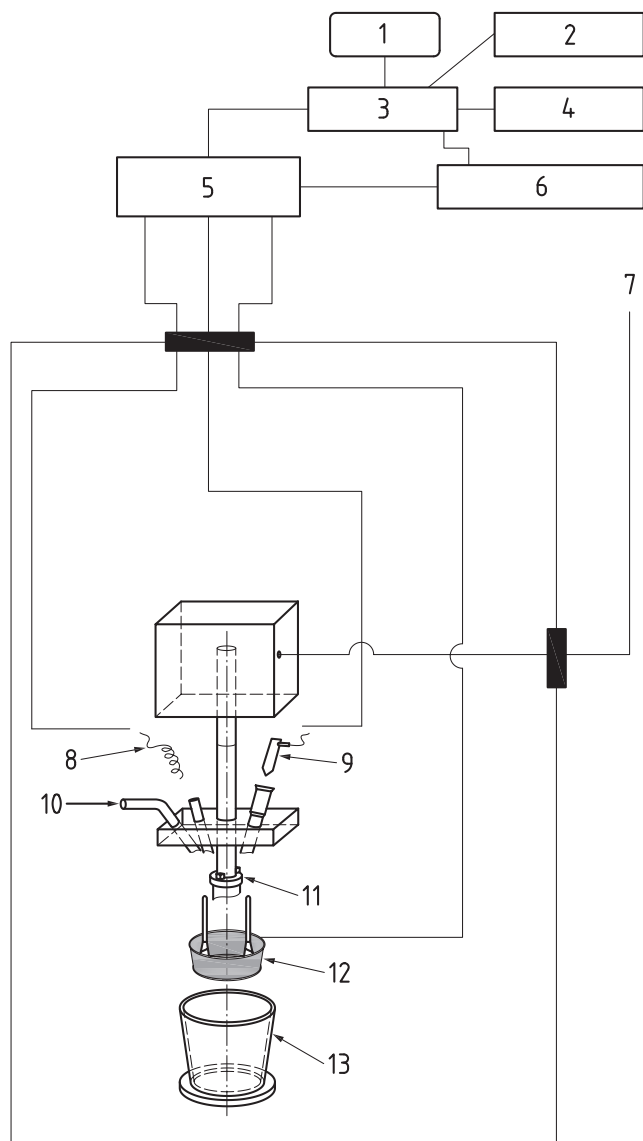

**Key**

- |                                  |  |
|----------------------------------|--|
| 1 video                          | 8 auxiliary (or counter) electrode in bridge tube filled with supporting electrolyte |
| 2 printer (optional)             | 9 reference electrode in bridge tube filled with supporting electrolyte              |
| 3 control computer               | 10 inert gas   |
| 4 keyboard                       | 11 stirrer   |
| 5 potentiostat and integrator    | 12 working electrode   |
| 6 digital voltmeter (DVM)        | 13 cell  |
| 7 AC/DC power for stirring motor |  |

**Figure 2 — Coulometric cell assembly connections**

**6.4.2 Instrumentation**, comprising the following<sup>[3][4]</sup>:

- a) **Potentiostat** with the desired range of electrolysis potentials for plutonium measurement and the following capabilities:
  - a power amplifier with a current output capability of 250 mA, or greater;

- a quick-response control-potential circuit, with maximum rise-time of 1 ms from zero volts to the desired control potential, with voltage overshoot not exceeding 1 mV;
- a control amplifier with a common-mode rejection of 90 dB, or greater;
- automatic control-potential adjustment, with a resolution of 0,001 V, or less;
- a voltage-follower amplifier, to isolate the reference electrode (electrometer), with a minimum input impedance of  $10^{11} \Omega$ ;
- capability to monitor the electrolysis current, including charging current for zero to 500 mA, with a detection capability of 0,5  $\mu\text{A}$ .

NOTE This procedure assumes that the coulometer has two accurate potentiometers, one for selecting the oxidation potential and the other for the reduction potential, although this is not a system requirement.

b) **Coulometric integrator** capable of integrating blank and test sample electrolysis currents from at least 150 mA down to 1  $\mu\text{A}$  with a readability of  $\pm 10 \mu\text{C}$  (refer to [7.1.4](#) for integrator capabilities and calibration requirements);

- The control-potential system should not drift more than  $\pm 1 \text{ mV}$  and the current integration system should not drift more than 0,005 % during routine measurements (between electrical calibrations), over the range of temperatures to which the control-potential circuitry will be exposed. If the room temperature varies excessively, the instrumentation should be located in a cabinet having temperature controls sufficient to limit electronic drift within these specifications.
- An electronic clock, with an uncertainty of  $\pm 0,002 \%$  ( $K = 1$ ) for determining the duration of electrical calibrations and electrolyses.
- A system for generating a known constant current, stable to  $\pm 0,002 \%$  over the range of temperatures to which the constant-current circuitry will be exposed. This system will be used for electrical calibration of the integration circuit of the coulometer, as described in [7.1.4](#).
- The cable connecting the potentiostat to the cell should be a three-wire conductor, twisted-shielded cable, preferably with the shield grounded at the potentiostat. Gold-plated connectors at the cell are recommended as these are not susceptible to corrosion.
- The charging-current peak maximum observed during the first 25 ms to 50 ms of the blank and test sample oxidations must be within the instrument specification for the integrator circuit. The surface area of the working electrode can be decreased to reduce the charging current peak maximum. An oscilloscope or a voltmeter with high-speed data acquisition is required to measure the amplitude of this peak, which has a typical width at half the maximum of 10 ms to 20 ms.

**6.5 Digital voltmeter (DVM)**, with an input impedance of  $10^{10} \Omega$  or greater and having an uncertainty within  $\pm 0,001 \%$  ( $K = 1$ ) for voltages in the range 0,5 V to 10 V, and within  $\pm 0,01 \%$  ( $K = 1$ ) for voltages in the range 100 mV to 500 mV. These uncertainties are required for electrical calibration of the instrumentation, as described in [7.1.4](#).

**6.6 Regulated power**, instrumentation should be protected with an uninterruptable power supply that provides a regulated voltage within  $\pm 1 \%$  of the standard for that particular country, and provides appropriate surge protection.

## 7 Procedure

### 7.1 Plutonium determination

#### 7.1.1 Weighing the test sample, with an uncertainty of $\pm 0,01$ %, $K = 1$ .

The test sample may be weighed after delivery into a tared coulometer cell, and the apparent mass corrected for the air buoyancy effect using either [Formula \(1\)](#) or [Formula \(2\)](#), as described below.

Alternatively, a known mass of the test sample may be delivered into the coulometer cell, as described in steps a) through f).

For test samples at high plutonium concentrations (e.g. 15 g/L or more), it is recommend that the solution be diluted to achieve an overall weighing uncertainty of  $\pm 0,01$  %.

If a weight burette made of polythene, or other material susceptible to static electricity, is used, then the problem of static electricity may be eliminated by contact between the dropping tube and a copper plate connected to the ground, or a similar arrangement.

- a) Fill a weighing burette with the solution to be analyzed.
- b) Weigh the burette to 0,1 mg.
- c) Deliver a test sample of at least 1 mL, drop by drop, into a coulometric cell, ensuring that at least 4 mg of plutonium has been delivered.
- d) Weigh the burette again to 0,1 mg.
- e) The mass difference gives the apparent mass,  $m_a$ , of the test sample in the cell.
- f) Correct the apparent mass of the test sample for the air buoyancy effect using [Formula \(1\)](#):

$$M_{\text{Real}} = M_a (1 - D_a/D_b) (1 - D_a/D_s)^{-1} \quad (1)$$

where

- $D_a$  is the density of air, which is a function of temperature, pressure, and humidity, but typically is between 0,001 16 g/cm<sup>3</sup> and 0,001 20 g/cm<sup>3</sup>;
- $D_b$  is the density of the stainless steel weights used in modern analytical balances, 8,0 g/cm<sup>3</sup>;
- $D_s$  is the density of the test sample.

In addition to applying an air buoyancy correction to the mass of the test sample, air buoyancy corrections should be applied to all mass measurements (including any bulk material mass measurements). This correction is required to eliminate systematic errors that can exceed 0,1 % for solutions. The correction is less for solids, but can still be significant.

For plutonium metal and alloy test samples, an additional buoyancy correction term for self-heating from radioactive decay, as detailed in [Formula \(2\)](#) is also appropriate.<sup>[5]</sup>

$$M_{\text{Real}} = M_a (1 - D_a/D_b) (1 - D_a/D_s)^{-1} (1 - \Delta m' \times M_a^{-2/3} \times Pu_{\text{heat}})^{-1} \quad (2)$$

where

- $M_a$  is the apparent mass, g;
- $\Delta m'$  is the mass coefficient for the heat buoyancy term, with a value of  $0,000\ 03\ \text{g}^{5/3}\ \text{mW}^{-1} \pm 0,000\ 01\ \text{g}^{5/3}\ \text{mW}^{-1}$  ( $1\sigma$ ) for test samples ranging from 1 g to 15 g;
- $Pu_{\text{heat}}$  is the specific-heat of the plutonium,  $\text{mW}\ \text{g}^{-1}$ , calculated from the plutonium isotopic abundance and  $^{241}\text{Am}$  content. This value is nominally  $2\ \text{mW}\ \text{g}^{-1}$  to  $3\ \text{mW}\ \text{g}^{-1}$  for plutonium with a burn up ranging from  $2\ \text{MWDKg}^{-1}$  to  $8\ \text{MWDKg}^{-1}$  (or GW-days per metric ton). The specific heat increases with higher reactor burn up and increased  $^{238}\text{Pu}$  content.

### 7.1.2 Preparation of the test sample

- a) Add 1 mL of sulphuric acid solution (5.3) to the coulometric cell containing the test sample.
- b) Place the cell containing the test sample into the sample evaporation system and carefully evaporate the liquid in the test sample so as to avoid splashing.
- c) Evaporate the remaining liquid in the test sample at a temperature sufficient to evolve fumes of  $\text{SO}_3$ , and continue until  $\text{SO}_3$  fumes are no longer observed and a residue of plutonium sulphate (pink/orange-coloured precipitate) is formed. Do not allow the solution to boil or splash as this will cause mechanical loss.

The colour of the plutonium sulphate is dependent on the type of lighting used in the laboratory. Under fluorescent lighting the dried sulphate is coral pink. Degradation of plutonium sulphate to plutonium oxide should not be expected even after baking the residue unless subjected to extremely high temperatures. Failure to use (i) high purity reagents, (ii) anion-exchange resins washed free of resin fines, and (iii) heating equipment that is well maintained and clean will impact the fuming operation adversely. Any or all of these failures can produce a visible black residue in combination with the dried sulphate powder. These residues could be mistaken for plutonium oxide, and depending on their composition might interfere in the coulometric measurement.

- d) Allow the test sample to cool to room temperature.
- e) If  $\text{Pu}^{6+}$  ( $\text{PuO}_2^{2+}$ ) is present, it shall be reduced to lower oxidation states ( $\text{Pu}^{3+}$  and  $\text{Pu}^{4+}$ ) prior to coulometric measurement by the addition of either hydrogen peroxide or nitrite ion or ferrous ion. The excess reducing agent shall be removed by purification or destroyed prior to coulometric measurement. Refer to [Clause 10](#) for details.
- f) If the presence of significant amounts of impurities is suspected, dissolve and purify the dried test sample to eliminate the interfering elements. Repeat the sulphuric acid fuming step as detailed in [7.1.2](#). Anion-exchange is an effective purification process; it is outlined in [Annex A](#).

### 7.1.3 Electrode pre-treatment

Electrode conditioning is critical to ensuring reproducibility. The following storage and treatment techniques may be used individually or in combination to condition the working and auxiliary electrodes:

- storing in 8 mol/L nitric acid when the electrodes are not in use (this storage technique is recommended as the general practice);
- soaking in concentrated nitric acid;

- soaking in concentrated sulphuric acid containing 10 % hydrofluoric acid, followed by 8 mol/L nitric acid;
- soaking in aqua regia (limited to several minutes to prevent damage to the working electrode);
- boiling in nitric acid;
- flaming the platinum auxiliary electrode to white or red heat.

Electrode treatment may be performed on a preventative basis, at the beginning and/or at the end of the day of electrode use. Alternatively, treatment may be on an “as needed” basis, particularly needed in case of failure to obtain optimum electrode performance in either the blank or the test sample measurements. The background current values (total mC, charging current mA maximum, and residual current  $\mu\text{A}$ ) should be reproducible for a given installation and are normally used as indicators of satisfactory performance.

Each day, or more often as desired, before performing the actual blank determination, further conditioning of the electrodes is achieved by performing the following sequence of electrolyses:

- a) Assemble the cell lid, complete with the electrodes and other internal equipment (6.4.1).
- b) Take a clean dry coulometric cell and add sufficient nitric acid solution (5.1) to immerse the working electrode, and the sintered-glass discs of the reference and auxiliary electrode tubes.
- c) Add one drop of amidosulphuric acid solution (5.2).
- d) Firmly fit the cell under the lid.
- e) Start the stirrer at the desired speed. This speed should be selected to maximize the stirring rate, while avoiding splashing or forming any excessive vortex that would interrupt electrical connections.
- f) Open the gas inlet and maintain a sufficient flow of inert gas throughout the electrolysis period. Inadequate purging to remove oxygen can be mistaken for an electrode-conditioning problem.
- g) Preselect the oxidation potential at  $E_0+0,32\text{ V}$  and the reduction potential at  $E_0-0,36\text{ V}$ .
- h) After degassing for 5 min, start the oxidation and oxidize at  $E_0+0,32\text{ V}$  until a residual current of  $10\ \mu\text{A}$  is obtained.
- i) Start the reduction and reduce at  $E_0-0,36\text{ V}$  until a residual current lower than  $10\ \mu\text{A}$  is obtained.
- j) Oxidize at  $E_0+0,32\text{ V}$ .
- k) Stop the electrolysis when the current is lower than  $10\ \mu\text{A}$ .
- l) Rinse the electrolysis cell and the outside wall of the fritted-glass tubes with fresh supporting electrolyte.
- m) Based upon electrode performance,
  - perform further electrode conditioning (see 7.1.3) until the desired performance is observed, or
  - measure the supporting electrode blank determination (see 7.1.6) in preparation for the subsequent measurement of plutonium test samples.

#### 7.1.4 Electrical calibration of the current integration system

The electrical calibration factor of the coulometer is measured by using a high accuracy, highly stable constant current in place of the electrolysis cell. Detailed instructions for the calibration of a current integration system are highly dependent upon the design of the specific integration circuit. However,



the following general principles and specifications apply toward determining the calibration factor within an uncertainty envelope not exceeding  $\pm 0,01\%$  ( $K = 1$ ).

- Generate a constant current (stable and known to within  $\pm 0,002\%$ ,  $K = 1$ ) in a manner that is electronically equivalent to the process by which the electrolysis current from the test sample and the blank are integrated.

NOTE Typically, the potentiostat is converted into a constant current source with the current flowing through a standard resistor, instead of the cell assembly. The voltage drop across the standard resistor is measured to determine accurately the actual calibration current. Alternatively, if a constant current source is used instead of the potentiostat, then this external source requires periodic calibration to ensure consistency and traceability.

- Determine the duration of calibration (i.e. current flow) within  $\sim 0,002\%$ ,  $K = 1$ .

The linearity of the integrator response shall be demonstrated for the range of currents observed during plutonium measurement ( $\sim 50\ \mu\text{A}$  to  $100\ \text{mA}$ ). Ensure that the impact of the integrator nonlinearity on the plutonium measurement is  $0,005\%$ ,  $K = 1$ , or less.

A typical sequence for performing an electrical calibration is:

- a) configure the instrumentation for electrical calibration and set to the desired constant current, for example  $10,000\ \text{mA}$ ;
- b) set the integration time to an appropriate duration, for example  $300\ \text{s}$ ;
- c) reset the integrator;
- d) allow time for the electronics to stabilize;
- e) initiate the calibration and record the constant current used,  $I_c$ ,  $\text{mA}$ ;
- f) at the completion of the calibration, record the output signal from the integrator,  $Q_c$  (in the units appropriate for the specific measurement system) and the actual calibration time,  $t_c$ , in seconds;

Electrical calibration should be performed at least daily and in the same laboratory where the plutonium measurements are performed. An automated coulometer should perform the electrical calibration without the user needing to reconfigure the instrumentation. Refer to [8.1](#).

### 7.1.5 Formal potential determination

The formal potential,  $E_0$ , of the  $\text{Pu}^{4+}/\text{Pu}^{3+}$  couple should be measured at regular intervals (as described in [Annex B](#)), especially when electrodes have been replaced or if the electrodes have been out of use for a considerable time. Before performing this measurement, ensure that the working and auxiliary electrodes have been properly pre-treated and conditioned. Also ensure that the SCE is filled with saturated potassium chloride solution and contains a few free-flowing salt crystals, but is not clogged by excessive amounts of salt crystals.

When the control potentials  $E_3$  and  $E_4$  are measured during the analysis of the test sample, as described in [7.1.7](#), these potentials are approximately equal to  $E_0 - 0,17\text{V}$  and  $E_0 + 0,17\text{V}$ , respectively. Thus, the average of  $E_3$  and  $E_4$  is highly correlated with  $E_0$ . The average of  $E_3$  and  $E_4$  may be plotted on a control chart and used as an indicator of the stability of the electrolysis cell and the reference electrode between periodic  $E_0$  determinations.

The formal potential is close to  $+0,668\ \text{V}$  vs SCE when nitric acid is used as the supporting electrolyte but small variations can be expected because different calomel electrodes exhibit slightly different potentials. The formal potential is also moderately dependent on the concentration of the nitric acid supporting electrolyte. The selection of a different supporting electrolyte such as  $0,5\ \text{mol/L}$  sulphuric acid would significantly shift the formal potential into the range of  $+0,492\ \text{V}$  vs SCE.

Failure to fume completely test samples to a dry plutonium residue before dissolving in nitric acid supporting electrolyte will result in an inconsistent shift of the formal potential due to the varying

amount of excess sulphuric acid. In the analysis of U/Pu mixed oxides, additional sulphate ions from dried uranium sulphate will also shift the formal potential as a function of the U:Pu ratio. The appropriate formal potential value should be used in [Formula \(6\)](#) when mixed oxide materials are assayed for plutonium.

### 7.1.6 Coulometric blank determination

Blank measurement parameters are set match the electrolysis conditions of the test sample. Optimum reliability in the blank value is obtained when the initial and final oxidation potentials during the blank and the test samples are matched as well as the duration of the blank and the test sample. Matching the current level at which the control potential is adjusted for both the blank and test sample is not appropriate. Refer to [8.2](#).

- a) Rinse the outside wall of the fritted-glass tubes and, if necessary, fill them up with 0,9 mol/L nitric acid solution ([5.1](#)).
- b) Repeat steps [7.1.3](#) b) to f).
- c) Preselect the oxidation potential at  $E_0+0,24$  V (SCE) and the reduction potential at  $E_0-0,26$  V (SCE).
- d) Degas the supporting electrolyte until dissolved oxygen is removed, as described in [6.4.1](#) c). Oxygen removal should be accomplished in about 5 min, or less.
- e) Start the oxidation at  $E_0+0,24$  V (SCE) until a residual current of approximately 5  $\mu$ A is obtained.
- f) Start the reduction at  $E_0-0,26$  V until the electrolysis current decreases to approximately 10  $\mu$ A, or less. (This should not take more than 2 min to 3 min if degassing is adequate.)
- g) Slowly raise the control potential to the typical final reduction potential of test samples (nominally  $E_0-0,17$  V), then allow the electrolysis current to equilibrate as needed (typically 30 s to 60 s) to a residual current in the range 1  $\mu$ A to 10  $\mu$ A. Ideally, this residual current is between 1  $\mu$ A and 3  $\mu$ A.
- h) Measure the control potential  $E_1$  supplied by the potentiostat at the end of the reduction step, using the DVM ([6.5](#)).
- i) Reset the integrator. The starting of the integrator and timer shall coincide with the beginning of the oxidation.
- j) Start the oxidation at  $E_0+0,24$  V and wait 200 s, or wait a period of time that matches the typical duration for the plutonium test sample to be oxidized to 1/750 of the initial current, or less.
- k) Slowly lower the control potential to the typical final oxidation potential of the plutonium test samples (nominally  $E_0+0,17$  V), then allow the electrolysis current to equilibrate as needed (typically 30 s to 60 s) to a residual current  $I_{r1}$  in the range 1  $\mu$ A to 10  $\mu$ A. Ideally, this residual current is between 1  $\mu$ A and 3  $\mu$ A.
- l) Measure the control potential  $E_2$  supplied by the potentiostat at the end of the oxidation step, using the DVM ([6.5](#)).
- m) Record
  - the final reduction and oxidation potentials,  $E_1$  and  $E_2$  (V),
  - the residual current,  $I_{r1}$  (mA),
  - the integrated current,  $Q_1$ , in the units of the output signal from the integrator (ideally, this quantity equates to 5 mC, or less), and
  - the electrolysis time,  $t_b$  (s).
- n) Stop the stirrer (and if desired, turn off the gas supply).

### 7.1.7 Plutonium measurement

- a) Transfer the nitric acid solution from the blank determination to the coulometric cell containing the dried test sample, taking care to rinse thoroughly the sample cell wall.
- b) Inspect the test sample solution to determine if the solid plutonium sulphate has dissolved completely. Even if the solids have not dissolved completely, continue with steps c) to g) below, but increase the degassing time in step g), as needed, to ensure complete dissolution.
- c) Firmly fit the cell under the lid.
- d) Start the stirrer.
- e) Ensure that the gas inlet is open and leave it open throughout the electrolysis period, as described in [6.4.1 c\)](#).
- f) Preselect the oxidation potential at  $E_0+0,24$  V (SCE) and the reduction potential at  $E_0-0,26$  V (SCE).
- g) Degas as described in [6.4.1 c\)](#) until dissolved oxygen is removed. Oxygen removal should be accomplished in 5 min, or less.
- h) Start the reduction at  $E_0-0,26$  V (SCE) and reduce until an electrolysis current is obtained that is 1/750 of the initial reduction current, or less, typically in the range of 50  $\mu\text{A}$  to 150  $\mu\text{A}$  depending upon the quantity of plutonium in the test sample. Reduction should not take more than 10 min, if the stirring and degassing are adequate.
- i) Slowly raise the potential so as to obtain an electrolysis current lower than 1  $\mu\text{A}$ , then allow the test solution to equilibrate (10 s to 60 s) to a stable residual current, typically between 1  $\mu\text{A}$  and 5  $\mu\text{A}$ .
- j) Measure the control potential  $E_3$  supplied by the potentiostat at the end of the reduction, using the DVM ([6.5](#)).  $E_3$  should be approximately  $E_0-0,17$  V.
- k) Reset the integrator and timer.
- l) Start the oxidation at  $E_0+0,24$  V (SCE) and oxidize until an electrolysis current is obtained that is 1/750 of the initial oxidation current, or less, typically in the range of 50  $\mu\text{A}$  to 150  $\mu\text{A}$  depending upon the quantity of plutonium in the test sample. This should not take more than 10 min, if the stirring is adequate.
- m) Slowly lower the potential so as to obtain an electrolysis current lower than 1  $\mu\text{A}$ , then allow the solution to equilibrate (10 s to 60 s) to a stable residual current  $I_{r2}$ , typically between 1  $\mu\text{A}$  and 5  $\mu\text{A}$ .
- n) Measure the control potential  $E_4$  supplied by the potentiostat at the end of the oxidation, using the DVM ([6.5](#)).  $E_4$  should be approximately  $E_0+0,17$  V.
- o) Record
  - the final reduction and oxidation potentials,  $E_3$  and  $E_4$  (V),
  - the residual oxidation current,  $I_{r2}$  (mA),
  - the integrated electrolysis current  $Q_S$ , in the units of the output signal from the integrator,
  - the electrolysis time,  $t_S$  (s), and
  - the temperature of the solution during electrolysis,  $T$  (K).

### 7.2 Analysis of subsequent test samples

Subsequent test samples that were weighed and prepared as described in [7.1.1](#) and [7.1.2](#), are measured as described in [7.1.6](#) and [7.1.7](#).

If no subsequent analysis will be performed:

- rinse the cell and components with supporting electrolyte or double-distilled water;
- store the reference electrode in a saturated solution of potassium chloride;
- store the working and the auxiliary electrodes in 8 mol/L nitric acid, or greater concentration.

NOTE The user may elect to implement other storage protocols, which they have demonstrated as effective for maintaining the desired electrode condition.

## 8 Expression of results

### 8.1 Calculation of the electrical calibration factor

Calculate the electrical calibration factor,  $C$ , using [Formula \(3\)](#). This factor is used to convert the integrator output signal to millicoulombs. The integrator output signal may be in pulses, volts, or directly in millicoulombs. In the last case, the electrical calibration factor is a quantity of dimension one.

$$C = I_C t_C Q_C^{-1} \quad (3)$$

where

$I_C$  is the constant current generated during the electrical calibration, mA;

$t_C$  is the time of the electrical calibration, s;

$Q_C$  is the integral of the calibration current, expressed in the units of the output signal from the integration system.

The electrical calibration factor calculated above should equal the theoretical value,  $C_{\text{theoretical}}$ , based upon circuit design and the measurement of key components in the circuit. However, the design and component layout may not lend themselves to the *in situ*, direct and independent measurement of load resistance,  $L_R$  and the response of the integrator to the input signal,  $R_S$ :

$$C_{\text{theoretical}} = L_R^{-1} R_S^{-1} \quad (4)$$

For example, if the electrolysis current signal supplied to the integrator is actually a voltage drop across a high precision 100,00  $\Omega$  load resistor and the integrator utilizes a voltage-to-frequency converter with a response of 10 000,0 Hz per volt, then the theoretical calibration factor is calculated as follows:

$$\begin{aligned} C_{\text{theoretical}} &= (100,00 \Omega \times 10\,000,0 \text{ Hz/V})^{-1} = 10^{-6} \Omega^{-1} \text{ V Hz}^{-1} = 10^{-6} \text{ A Hz}^{-1} = 10^{-6} \text{ A s pulse}^{-1} \\ &= 1,000\,0 \times 10^{-6} \text{ coulombs/pulse} = 1,000\,0 \mu\text{C/pulse} \end{aligned}$$

### 8.2 Calculation of the blank

The integrated current  $Q_1$ , obtained during the coulometric blank determination ([7.1.6](#)) is used to calculate the blank correction that is appropriate for the conditions observed during the plutonium determination.

The value of the blank correction,  $Q_b$ , is given by the following formula:

$$Q_b = (Q_1 C - I_{r1} t_1) (E_4 - E_3) (E_2 - E_1)^{-1} + I_{r2} t_2 \quad (5)$$

where

- $C$  is the electrical calibration factor, calculated using [Formula \(3\)](#);
- $E_1$  is the control potential measured at the completion of the blank reduction, V;
- $E_2$  is the control potential measured at the completion of the blank oxidation, V;
- $E_3$  is the control potential measured at the completion of the plutonium reduction, V;
- $E_4$  is the control potential measured at the completion of the plutonium oxidation, V;
- $Q_1$  is the integral of the current from the blank determination, expressed in the units of the output signal from the integration system, (measured during the oxidation between potentials  $E_1$  and  $E_2$ );
- $t_1$  is the electrolysis time for oxidation of the blank, s;
- $t_2$  is the electrolysis time for oxidation of the plutonium, s;
- $I_{r1}$  is the residual current after oxidation of the blank, mA;
- $I_{r2}$  is the residual current after oxidation of plutonium, mA.

The parameters of the blank measurement are fully optimized when  $E_1 = E_3$ ,  $E_2 = E_4$ , and  $t_2 = t_1$ . Under these ideal conditions, the term  $(E_4 - E_3)/(E_2 - E_1)$  in [Formula \(5\)](#) is equal to unity; the correction for constant background current is minimized when using [Formula \(5\)](#) and the value of  $Q_b$  is approximately that of  $Q_1$ .

### 8.3 Fraction of electrolysed plutonium

The fraction of electrolysed plutonium,  $f$ , is given by the following formula:

$$f = \frac{e^{\frac{nF(E_4 - E_0)}{RT}}}{1 + e^{\frac{nF(E_4 - E_0)}{RT}}} - \frac{e^{\frac{nF(E_3 - E_0)}{RT}}}{1 + e^{\frac{nF(E_3 - E_0)}{RT}}} \quad (6)$$

where

- $E_0$  is the formal potential of the  $\text{Pu}^{4+}/\text{Pu}^{3+}$  couple in the 0,9 mol/L nitric acid supporting electrolyte, V;  
NOTE This potential is determined with chemically pure plutonium analyzed in the same manner as the test sample (see [Annex B](#)).
- $R$  is the molar gas constant;  $R = 8,3145 \text{ J mol}^{-1} \text{ K}^{-1}$  [\[6\]](#)[\[7\]](#)
- $T$  is the absolute temperature, in Kelvin, of the solution during electrolysis ( $T = T_C + 273,15$ ) where  $T_C$  is the temperature in °C;
- $F$  is the Faraday constant;  $F = 96 485,34 \text{ C mol}^{-1}$  [\[6\]](#)[\[7\]](#)
- $n$  is the number of moles of electrons exchanged per mole of plutonium electrolysed,  $n = 1$  (a dimensionless quantity; i.e. a quantity of dimension one).

NOTE 1 For integration data collected from current cut-off measurements made before reaching a residual current without using the control-potential adjustment technique detailed in this document, the correction  $f$  based on the control potentials applied during reduction and oxidation would be inaccurate. Refer to [Clause 11](#) for details.

NOTE 2 The current CODATA values for the Faraday constant and the molar gas constant are available at <http://physics.nist.gov/cuu/Constants/index.html>.

## 8.4 Plutonium content

The plutonium content in the test sample,  $m_{Pu}$ , expressed in milligrams, is given by [Formula \(7\)](#):

$$m_{Pu} = (Q_s C - Q_b) A_r F^{-1} f^{-1} \quad (7)$$

where

$Q_s$  is the integral of the electrolysis current, expressed in the units of the output signal from the integration system, during plutonium oxidation between the equilibrium potentials  $E_3$  and  $E_4$ ;

$Q_b$  is the calculated blank from [Formula \(5\)](#), mC;

$A_r$  is the relative atomic mass of plutonium calculated from its isotopic composition, g mol<sup>-1</sup>;

$C$  is the electrical calibration factor from [Formula \(3\)](#);

$F$  is the Faraday constant;

$f$  is the fraction of plutonium electrolysed from [Formula \(6\)](#).

## 8.5 Quality control

Electrical calibration of the instrumentation provides an accurate and reliable conversion of the integrator output signal into millicoulombs, from which the plutonium content is calculated. Electrical calibration does not independently test all of the parameters involved in measuring plutonium. A reliable quality-control programme<sup>[8][9]</sup> based upon analysis of traceable standard reference materials (see ISO 10980) is needed to verify, reliability of mass measurements and proper fuming of the test samples with sulphuric acid; quantitative recovery of plutonium, if anion-exchange purification is used; satisfactory electrode treatment and conditioning practices (verified through consistently low background currents during the blank and test sample measurements); reliability in instrument operations; and the overall performance of the analyst. Control charting is recommended for (i) quality-control standards measured utilising electrical calibration; (ii) electrical calibration data, (iii) periodic formal potential,  $E_0$ , measurements and (iv) the average of the  $E_3$  and  $E_4$  potentials measurements. A distinct advantage of combining electrical calibration and traceable quality-control standards is the increased confidence from independently ensuring system performance, demonstration of measurement uncertainty, and the ability to monitor all aspects of the measurement process including the preparation and control of plutonium reference materials. Accreditation of the user's coulometric measurement capabilities in accordance with ISO 17025 and participation in external sample exchange programmes and/or performance evaluation test programmes will enhance measurement quality assurance and continuous improvement efforts.

## 9 Characteristics of the method

### 9.1 Repeatability

The short-term repeatability has been demonstrated by several laboratories through measurements of certified reference materials yielding results with relative standard deviation (1-sigma) of 0,02 % to 0,03 %. The long-term repeatability has been demonstrated by these same laboratories to be 0,04 %

to 0,08 % (1-sigma). The long-term precision estimate is based on routine measurements of quality-control standards and replicate measurements of test samples that meet the requirements given in [Clause 1](#).

## 9.2 Confidence interval

Short-term and long-term systematic errors have been demonstrated to be  $\pm 0,03$  % or less,  $K = 2$ . Combining systematic and random errors yields a confidence interval of  $\pm 0,1$  % to  $\pm 0,2$  % at the confidence level of 0,95 for a single determination ( $K = 2$ ).

The measurement uncertainty and associated coverage factor reported with plutonium assay results should be computed in accordance with JCGM 100.

## 9.3 Analysis time

The time needed for a plutonium determination is 30 min to 60 min depending upon the cell design, electrode conditioning, and the selection of measurement parameters. Electrolysis times for the blank and test sample can be longer if conditions are not optimized.

## 10 Interferences

Iron present at 500  $\mu\text{g/g}$  of plutonium increases the plutonium result by about 0,1 % in nitric acid supporting electrolyte. If the iron content is both known and equal to 2 000  $\mu\text{g/g}$  plutonium or less, and the formal potential of pure iron has been measured for the system, then a mathematical correction for the iron is possible. The fraction of iron that would be electrolysed along with plutonium can be calculated using [Formula \(6\)](#) by substituting the formal potential of the  $\text{Fe}^{3+}/\text{Fe}^{2+}$  couple for  $E_0$ . See [Table 1](#) for calculations of  $f$  for impurity elements that are reversible couples.

**Table 1 — Fraction electrolysed for impurity elements**

Given  $E_0(\text{Pu}) = 0,668$  V vs SCE

Given plutonium control-potential adjustment at 1/750 of the initial electrolysis currents.

Assuming final plutonium solution potentials: reduction,  $E_3$ , at 0,500 V vs SCE and oxidation,  $E_4$ , at 0,836 V vs SCE.

$E_0$ (impurity) vs SCE	Fraction of impurity reduced during plutonium reduction	Fraction of impurity oxidized during plutonium oxidation	Total fraction of impurity electrolysed during Pu measurement, $f_{\text{impurity}}$
	0,002 9	1,000 0	0,002 9
0,350	0,007 6	1,000 0	0,007 6
0,375	0,020 0	1,000 0	0,020 0
0,400	0,051 2	1,000 0	0,051 2
0,425	0,125 0	1,000 0	0,125 0
0,450	0,274 3	1,000 0	0,274 3
0,475	0,500 0	1,000 0	0,500 0
0,500	0,725 7	1,000 0	0,725 7
0,525	0,875 0	1,000 0	0,875 0
0,550	0,948 8	1,000 0	0,948 8
0,575	0,980 0	0,999 9	0,979 9
0,600	0,992 4	0,999 7	0,992 1
0,625	0,997 1	0,999 3	0,996 4

**Table 1** (continued)

$E_0$ (impurity) vs SCE	Fraction of impurity reduced during plutonium reduction	Fraction of impurity oxidized during plutonium oxidation	Total fraction of impurity electrolysed during Pu measurement, $f_{\text{impurity}}$
0,650	0,998 9	0,998 1	0,997 0
0,675	0,999 6	0,995 0	0,994 6
0,700	0,999 8	0,986 9	0,986 7
0,725	0,999 9	0,966 0	0,966 0
0,750	1,000 0	0,914 9	0,914 8
0,775	1,000 0	0,802 4	0,802 4
0,800	1,000 0	0,605 4	0,605 4
0,825	1,000 0	0,367 0	0,367 0
0,850	1,000 0	0,179 7	0,179 7
0,875	1,000 0	0,076 5	0,076 5
0,900	1,000 0	0,030 3	0,030 3
0,925	1,000 0	0,011 7	0,011 7
0,950	1,000 0	0,004 4	0,004 4
0,975	1,000 0	0,001 7	0,001 7

The information in [Table 1](#) is only applicable for a reversible couple, such as iron or neptunium.

The mass of plutonium corrected for iron impurity,  $m_{\text{Pu-Fe}}$ , is calculated as follows:

$$m_{\text{Pu-Fe}} = m_{\text{Pu}} - m_{\text{Fe}} f_{\text{Fe}} f_{\text{Pu}}^{-1} A_{\text{rPu}} A_{\text{rFe}}^{-1} \quad (8)$$

where

$m_{\text{Pu}}$  is the mass of plutonium, mg [from [Formula \(7\)](#)];

$m_{\text{Fe}}$  is the mass of iron (mg) in the test sample, based upon the measurement of the iron impurity content by an appropriate measurement technique such as spectrophotometry, inductively coupled plasma optical emission spectrometry or inductively coupled plasma mass spectrometry;

$f_{\text{Fe}}$  is the fraction of iron electrolysed, calculated based on [Formula \(6\)](#), with  $E_0$  assigned the value of the formal potential of iron;

$f_{\text{Pu}}$  is the fraction of plutonium electrolysed from [Formula \(6\)](#);

$A_{\text{rPu}}$  is the relative atomic mass of plutonium calculated from its isotopic composition, g mol<sup>-1</sup>;

$A_{\text{rFe}}$  is the relative atomic mass of iron, 55,845, g mol<sup>-1</sup> (see IUPAC 2009[12]; use most current IUPAC value).

The uncertainty in the iron content in the test sample,  $m_{\text{Fe}}$ , depends upon the uncertainty and the detection limit of the method used to determine the iron content. For nuclear grade materials, the uncertainty in the iron content should be a minor component in the uncertainty budget for the plutonium assay.

The uncertainty in  $f_{\text{Fe}}$  is dependent upon the potential difference between the plutonium reduction potential and the formal potential of the iron. The closer these potentials are, the greater the uncertainty. This is illustrated in [Table 1](#) by the rapid change in the fraction electrolysed when the formal potential of an impurity is close to either the final plutonium reduction or oxidation potentials.



A 25-mV difference in potentials will shift the fraction of the impurity electrolysed from 0,50 to either 0,27 or 0,73, depending upon the direction of the shift.

When the  $E_0$  of the impurity element is within 70 mV of the  $E_0$  of Pu, the fraction electrolysed approaches unity and the interference can be assumed to be quantitative given the typical uncertainties associated with the concentration measurement of the trace impurity. This situation is observed for iron in sulphuric acid supporting electrolyte. Refer to [Clause 11](#) for additional details.

Neptunium interferes with plutonium measurement in nitric acid supporting electrolyte.  $\text{Np}^{4+}$  is especially problematic since it does not react electrochemically at the same rate as the reversible  $\text{Np}^{6+}/\text{Np}^{5+}$  ( $\text{NpO}_2^{2+}/\text{NpO}_2^+$ ) couple. The percentage of neptunium in the  $\text{Np}^{4+}$  oxidation state is dependent on the sample source and sample pre-treatment, therefore uncertainty in making the neptunium correction depends not only on the uncertainty in the neptunium impurity measurements and the fraction of the neptunium involved in the reversible reaction of  $\text{Np}^{6+}/\text{Np}^{5+}$  ( $\text{NpO}_2^{2+}/\text{NpO}_2^+$ ), but also upon ensuring complete oxidation of  $\text{Np}^{4+}$  prior to the oxidation of the plutonium in a manner that does not adversely impact background current levels during the plutonium measurements.

Interference from uranium has been reported by some but not all users. The mechanism for the reported interference is not well understood. The discussion in [7.1.5](#) for determining the formal potential of the plutonium as a function of the Pu:U ratio may be effective at addressing part or all of the reported interference from uranium.

If  $\text{Pu}^{6+}$  ( $\text{PuO}_2^{2+}$ ) is present, it shall be reduced to  $\text{Pu}^{4+}$  prior to coulometric assay. Several options are available for reducing  $\text{Pu}^{6+}$  ( $\text{PuO}_2^{2+}$ ):

- Reducing  $\text{Pu}^{6+}$  ( $\text{PuO}_2^{2+}$ ) with ferrous ion is effective. Since iron interferes it must be removed by anion exchange prior to coulometric measurement. Following the coulometric measurement, the iron content of the solution should be measured to make the correction using [Formula \(8\)](#).
- The  $\text{Pu}^{6+}$  ( $\text{PuO}_2^{2+}$ ) can also be reduced with  $\text{H}_2\text{O}_2$  preceding the fuming step by the addition of 50  $\mu\text{L}$  to 100  $\mu\text{L}$  of 30 % hydrogen peroxide to the test sample solution in 8 mol/L nitric acid. Cover the test sample with a watch glass to prevent loss of solution from slow effervescence caused by the  $\text{H}_2\text{O}_2$  reaction. After several hours the test solution should turn blue indicating complete reduction of the  $\text{Pu}^{6+}$  ( $\text{PuO}_2^{2+}$ ) to  $\text{Pu}^{3+}$ . The solution should then be gently heated on a hot plate to oxidize the plutonium to  $\text{Pu}^{4+}$ , as indicated by a colour change in the solution to green. The condensate on the watch glass should then be rinsed into the test sample, sulphuric acid added, and the solution fumed to dryness. If the test sample is heated with overhead lamps instead of a hot plate, then sulphuric acid should be added before this heating step to prevent the drying of the condensate on the watch glass as the condensate may contain traces of the dissolved plutonium spattered from the effervescent reaction of the peroxide. If the nitric acid condensate dries on the watch glass, the resulting plutonium nitrate salt can oxidize and the resulting residue may not readily dissolve when the watchglass is rinsed.
- The addition of  $\text{NO}_2^-$  to test samples dissolved in dilute nitric acid preceding the fuming step could be used to reduce  $\text{Pu}^{6+}$  ( $\text{PuO}_2^{2+}$ ) to  $\text{Pu}^{4+}$ .

Humidifying the inert gas by bubbling it through a reservoir of reagent water will (i) restore some of the heat lost by the gas from expansion prior to its introduction into the coulometer cell and (ii) minimize evaporation of the solution into the moist gas. Controlling temperature and humidity of the inert gas decreases the rate of evaporation of the supporting electrolyte and the resulting cooling during the measurement of the blank and sample.

In principle, anion-exchange purification (see [Annex A](#)) can be effective at removing the interferences referenced above and in [Figure 3](#), and achieving quantitative plutonium recovery<sup>[13][14]</sup>. It is recommended that plutonium solutions in 7,8 mol/L nitric acid be treated with  $\text{NO}_2^-$  when neptunium is present. After  $\text{NO}_2^-$  addition, heat the solution to 70 °C to 80 °C for 10 min to obtain  $\text{Np}^{5+}$  ( $\text{NpO}_2^+$ ). This step ensures separation of plutonium from neptunium in the anion exchange method, since  $\text{Np}^{5+}$  ( $\text{NpO}_2^+$ ) is not adsorbed by the resin. In general, fuming to dryness in sulphuric acid and oxidation state adjustment must be done to obtain the hexa-nitrato plutonium (iv) anion complex in the loading solution in 7,8 mol/L nitric acid for the anion exchange purification method. Attention to reagent purity,

resin selection, and good experimental technique (loading the solution, washing, and elution) are other critical parameters to achieve quantitative separation and recovery of plutonium free from interfering impurity elements<sup>[14]</sup>.

Gold, iridium, palladium, and platinum interfere quantitatively and are not easily removed by anion-exchange purification. However, these elements are rarely ever present in sufficient abundance in nuclear grade plutonium to be of a cause for concern.

Fuming in the presence of sulphuric acid is an essential step in the plutonium measurement method described in this document, independent of the dilute mineral acid selected for the supporting electrolyte selected. The fuming step helps to eliminate interferences from organic materials and other anions if originally present in the test sample. Analysis of test samples that have not been fumed is likely to result in degradation of electrode performance and may result in induced background current during the plutonium measurement that is not included in the background current from the blank measurement.

Organic compounds interfere through electrochemical reactions and through coating of the working electrode resulting in degraded performance. Volatile organic compounds are removed by fuming to dryness in sulphuric acid. Drying in sulphuric acid also facilitates conversion of some organic material to inert ash, which does not interfere in the analysis.

The anions chloride, fluoride, nitrate, and nitrite and the inorganic reducing agent hydroxylamine are removed by fuming to dryness in sulphuric acid.

Nitrite anions in the nitric acid supporting electrolyte are destroyed by adding amidosulphuric acid.

Elements that are not quantitatively removed by the anion-exchange purification and elements that interfere in the quantitative electrochemical oxidation of the Pu<sup>4+</sup>/Pu<sup>3+</sup> couple are shown in [Figure 3](#).

H																	He
Li	Be											B	C	N	O	F	Ne
Na	Mg											Al	Si	P	S	Cl	Ar
K	Ca	Sc	Ti	K	Cr	Mn	<u>Fe</u>	Co	Ni	Cu	Zn	Ga	Ge	As	Se	Br	Kr
Rb	Sr	Y	Zr	<i>Nb</i>	Mo	Tc	Ru	Rh	<i>Pd</i>	<i>Ag</i>	Cd	In	Sn	Sb	Te	I	Xe
Cs	Ba	<i>La</i>	Hf	<i>Ta</i>	W	Re	Os	<i>Ir</i>	<i>Pt</i>	<i>Au</i>	Hg	<i>Tl</i>	Pb	Bi	Po	At	Rn
K	Ca	Sc															
<i>Lanthanides</i>	<i>Ce</i>	Pr	Nd	Pm	Sm	Eu	Gd	Tb	Dy	Ho	Er	Tm	Yb	Lu			
<i>Actinides</i>	<i>Th</i>	Pa	U	<i>Np</i>	Pu	Am	Cm	Bk	Cf	Es	Fm	Md	No	Lr			

The boxes for the elements Fe, Pd, Ir, Pt, Au, and Np are marked with diagonal lines in the periodic table to indicate that these elements interfere during plutonium measurement as described in this document. Fe is removed by the anion exchange purification described in this document. The symbols for the elements *Pd*, *Ir*, *Pt*, *Au*, and *Np*, along with the elements that do not interfere: *Nb*, *Ag*, *La*, *Ta*, *Tl*, *Ce*, and *Th*, are shown in italics to indicate that these elements remain with the plutonium after anion exchange purification.

**Figure 3 — Elemental interferences in plutonium coulometry**

## 11 Procedure variations and optimization

### 11.1 Accountability measurements and reference material preparation

Controlled-potential coulometric determination of plutonium is an important analytical technique in accountability measurements and reference material preparation. Minimizing measurement and sampling uncertainties and providing clear traceability to the International System of Units, SI<sup>[15]</sup>, are integral components of the analytical procedure described in this document. The impacts from sampling and measurement uncertainties are understood for safeguards and the accountability applications, and do not require further discussion within this document. For estimating uncertainties in nuclear material sampling refer to applicable International Standards and guidelines<sup>[16]</sup>.

### 11.2 Process control measurements

Applying controlled-potential coulometry to process control measurements, especially if the plutonium measurement is used to make process decisions that are important to nuclear safety, requires the same rigor as in routine material accountability measurement, although some specifics will vary. A well developed and qualified sampling procedure and knowledge of the plutonium matrix, especially with respect to the purity of the material, are a few of those specific needed for process control measurements. The point where the process is sampled shall be demonstrated to be free from significant interferences or the test sample shall be purified appropriately. The ability to detect independently a process upset condition, especially one that can be anticipated to introduce interferences that are not normally present, shall be a part of the sampling and analysis strategy. The consequence of sampling and analytical errors shall be well defined and mitigating actions shall be taken to minimize the consequence from these error sources as well as reduce their frequency. The replication processes should also be well understood and arranged to eliminate common mode failures from the sampling and measurement process or from the individuals providing these services. Validation measurements such as solution density on replicate test samples, physical inspection of test samples, and independent verification of the sampling process can be effective tools for identifying and controlling sampling errors and identifying process upsets. Certain applications, especially those demanding a high reliability such as nuclear criticality prevention, may require verification by a second plutonium measurement method for example isotope dilution mass spectrometry. Application of two different analytical techniques helps to identify hidden or unaccounted sources contributing to measurement errors in either of the techniques.

### 11.3 Measurement cell design

The cell design presented in this document is known to be effective for plutonium coulometric analysis. However, other cell designs may be more efficient or reduce the background current by: minimizing electrolyte volume; decreasing the working electrode size; increasing ratio of the area of the working electrode to the volume of electrolyte; and/or positioning of the auxiliary electrode more symmetrically with respect to the working electrode<sup>[17][18]</sup>.

The smaller the quantity of plutonium taken for the test sample, the more significant is the background correction and the higher the uncertainty contribution from it. To reduce these uncertainties it may be desirable to optimize the cell parameters to reduce the background current. It is important to note that any new cell design shall be qualified for plutonium measurement with appropriate testing.

The cell design shown in this document uses a SCE that is separated from the test solution by an electrolysis bridge (sintered glass tube) that is filled with the supporting electrolyte. This design should minimize or eliminate any leakage of chloride ion from the saturated KCl solution. A few, free flowing crystals of KCl in the reference electrode indicate that the solution is saturated, however excessive crystal formation will impact the performance of the reference electrode.

An alternative to SCE is the silver/silver chloride (Ag/AgCl) reference electrode. Instead of SCE or Ag/AgCl electrodes, a mercury (I) sulphate reference electrode may be used to eliminate the source of chloride ions. The formal potential,  $E_0$ , value of the plutonium couple depends upon the reference

electrode selected and shall be determined experimentally and the controlled potentials for plutonium reduction and oxidation are set based on this experimentally determined value.

#### 11.4 Electrolyte and electrode options

Other options that are considered within the existing scope of this document are:

- substituting platinum or platinum alloy for gold as the working electrode;
- using dilute sulphuric acid as the supporting electrolyte;
- using dilute nitric acid at a concentration other than 0,9 mol/L.

Platinum and platinum alloy electrodes may require flaming (to white heat) to achieve optimum electrode condition, if boiling in nitric acid is not effective.

Dilute sulphuric acid may be used as the supporting electrolyte provided the formal potential is measured in the concentration of acid selected and the dissolved oxygen in the supporting electrolyte is removed exhaustively prior to measuring the blank and the test sample. Sulphuric acid has the advantage that neptunium does not interfere in the plutonium measurement.

When oxygen is properly removed, sulphuric acid can be an excellent choice for a supporting electrolyte. However, the significance of effective oxygen removal (i.e. degassing with an inert gas) in sulphuric acid supporting electrolyte cannot be underestimated. Cell assemblies with an optimized design, an adequate inert-gas flow rate, and a tight fit, will remove oxygen from sulphuric acid in 10 min or less. The time required to remove oxygen from the solution should be established by users based on testing of their cell assembly under routine conditions. If the purging time before beginning any electrolyses is not adequate to remove oxygen and the flow rate is not sufficient to prevent diffusion of oxygen into the cell then high and erratic background currents will be obtained, resulting in increased measurement times, inaccurate control-potential adjustments, and serious measurement biases for both the blank and the test sample.

Dilute nitric acid at a concentration other than 0,9 mol/L may be used provided the formal potential is measured in the concentration of acid selected.

#### 11.5 Test sample size

Amounts of plutonium in the test sample above 15 mg are acceptable, but may not significantly improve overall measurement reliability unless background currents are unusually high. Achieving low background currents is an important objective and therefore large size test samples are usually not needed.

Test samples containing less than 4 mg of plutonium can be measured using this document. However, background current and plutonium solution potential measurements require more stringent controls. Cell designs should be optimized to minimize the background currents and their variability so that their contributions to the overall measurement error are not excessive. In addition, the control-potential adjustments shall be performed more slowly to avoid even small reversals in the polarity of the electrolysis current. For smaller quantities of plutonium reversals in polarity can cause significant shifts in the plutonium solution potential that move it close to the formal potential than desired. The uncertainty in determining the plutonium solution potential from measuring the control potential also increases for smaller test sample sizes.

#### 11.6 Background current corrections

The measurement of the background current should test the full range of the electrode/electrolyte performance for both reduction and oxidation. The criteria established for the blank measurement should be verified during each blank measurement or at least routinely, such as at the start of the day, before measuring test samples. Although the background criteria established for a specific cell design, electrode material and electrolyte are expected to vary, the total accumulated background current (blank) for a properly conditioned working electrode should be reproducible. The blank measured from

a 5-min electrolysis should be less than 5 mC (equivalent to 12 µg Pu). The blank electrolysis current for both reduction and oxidation should reach 30 µA in less than 1 min and a residual current of less than 10 µA in 2 min to 3 min. If these criteria are not met, then the user should investigate the effectiveness of oxygen removal, electrode conditioning, and cell-design parameters (e.g. electrode connections, working electrode size, electrolyte volume, stirring speed and electrode configuration). The capability to achieve low residual current during both blank and test sample measurement is equally important for reduction and oxidation. However, integrated current is measured during the oxidation only for both the blank and the sample. The control-potential adjustment technique depends upon achieving low residual current for both reduction and oxidation steps on the order of 5 µA or less. Under these conditions, the solution potential determined from measuring the control potential at or near 0 µA is reliable.

The uncertainty in the measurement of the supporting electrolyte blank may be reduced by matching the duration of the blank oxidation to the typical test sample electrolysis time. Simulating the control-potential adjustment for the blank measurement should be performed at approximately the same time required for the test sample to reach the desired (low) current level where the control potential is adjusted. Do not perform this adjustment when the blank reaches the same (low) current level. If the latter was done, the majority of the blank electrolysis would be performed at a potential that matched the end-point for the test sample electrolysis rather than at the actual control potential applied during most of the electrolysis of the test sample. Residual background currents at the different control potentials may be different and would thus increase the uncertainty in the blank correction.

The residual background current values,  $I_{r1}$  and  $I_{r2}$ , are measured values, at the completion of the blank and test sample electrolysis, which only approximate the actual residual background currents at the initial control potential used during most of the blank and test sample measurements. As such, these measured values are estimates of the residual currents actually experienced during the electrolyses. Periodically, the actual residual currents of a blank and a test sample should be measured at  $E_0+0,24$  V by performing an exhaustive electrolysis of each to ensure that the uncertainty associated with this methodology is not significant for the method, as performed by the individual laboratory. These periodically measured values may be used in place of the measured  $I_{r1}$  and  $I_{r2}$  values when calculating the blank correction,  $Q_b$ , using [Formula \(5\)](#).

### 11.7 Correction for iron

The procedure presented in this document is for the measurement of test samples containing pure or purified plutonium. [Clause 10](#), Interferences, provides an option for correcting the plutonium result for the interference due to iron in the test sample. The correction methodology is valid provided that

- iron is the only significant interfering impurity present in the test sample of nuclear grade material,
- iron is measured independently and with sufficient accuracy using an appropriate trace level measurement technique, and
- the formal potential of pure iron is measured using the same protocol provided in [Annex B](#) for plutonium, with sufficient reliability to calculate accurately the fraction of iron electrolysed during the plutonium measurement, using the same calculation methodology provided by [Formula \(6\)](#).

If a dilute sulphuric acid supporting electrolyte is selected, the first two requirements remain the same. However, in dilute sulphuric acid the formal potentials of plutonium and iron are sufficiently close that their fractions electrolysed are approximately the same. Thus, iron impurity content can be subtracted from total plutonium on an atom-for-atom basis. [Formula \(8\)](#) simplifies to:

$$m_{\text{Pu-Fe}} = m_{\text{Pu}} - m_{\text{Fe}} A_{\text{rPu}} A_{\text{rFe}}^{-1} \quad (9)$$

Thus, in sulphuric acid supporting electrolyte, a mathematical correction for iron is larger per microgram of iron compared to nitric acid supporting electrolyte, but the uncertainty in this correction is not dependent upon the fraction of iron electrolysed since the formal potentials of plutonium and iron are similar in this acid.

## 11.8 Control-potential adjustment

The selection of the electrolysis current level of 1/750 of the initial electrolysis current at which to begin the control-potential adjustment is somewhat arbitrary. Selecting 1/500 of the initial electrolysis current to initiate this adjustment will increase the uncertainty in the determination of the fraction of plutonium electrolysed to  $\pm 0,02\%$ ,  $K = 1$ , while decreasing slightly the total electrolysis time and thus decreasing the size of the background current correction. Alternatively, selecting 1/1 000 of the initial electrolysis current will decrease the uncertainty in the fraction electrolysed to  $\pm 0,01\%$ ,  $K = 1$ , or less at the expense of efficiency and an increase in the total background current correction. However, if a correction in excess of 0,05 % will be made for the interference from iron in the test sample, the electrolysis current level at which to begin the control-potential adjustment for the sample reduction should be selected to control the uncertainty in the calculation of the fraction of iron electrolysed,  $f_{\text{Fe}}$ . This is accomplished by ensuring that the control potential at the end of the test sample reduction,  $E_3$ , is at least 50 mV away from the formal potential of iron,  $E_0(\text{Fe})$ . Values of 1/1 000 or greater are sometimes required to accomplish this objective.

Although the following methodology and calculation is outside the scope of this document, it is provided to clarify the key components in calculating the fraction electrolysed. If a current cut-off end-point greater than the residual current is chosen, without using the control-potential adjustment to locate the solution potential, then the formula for calculating the fraction electrolysed is not complete. In addition to calculating the fraction electrolysed from the control potentials applied using [Formula \(6\)](#), a further correction would be required based on the ratio of the initial and final electrolysis current for both the test sample reduction and oxidation:

$$f_{\text{cutoff}} = f \times (1 - I_{\text{fr}} I_{\text{ir}}^{-1} - I_{\text{fo}} I_{\text{io}}^{-1}) \quad (10)$$

where

- $f$  is the fraction electrolysed, [Formula \(6\)](#);
- $I_{\text{fr}}$  is the final electrolysis current, sample reduction cut-off well before reaching residual current;
- $I_{\text{fo}}$  is the final electrolysis current, sample oxidation cut-off well before reaching residual current;
- $I_{\text{ir}}$  is the initial electrolysis current, at start of sample reduction ( $t = 0$  s);
- $I_{\text{io}}$  is the initial electrolysis current, at start of sample oxidation ( $t = 0$  s).

If the current cut-off is actually close to the residual current, the correction is significantly smaller, since the variables,  $I_{\text{fr}}$  and  $I_{\text{fo}}$ , should be reduced by the actual residual currents for reduction and oxidation, respectively, before substituting in the [Formula \(10\)](#).

## 11.9 Calibration methodologies

The methodology described in this document is optimized for electrical calibration. Traceability to the national measurement system is achieved through electrical standards and the Faraday constant. Traceability may also be achieved through chemical calibration using appropriate traceable plutonium reference materials for both calibration and quality control, provided the measurement procedure is optimized for chemical calibration. Both calibration methodologies are effective, reliable, and have combined uncertainties that are comparable when the individual procedures are optimized appropriately.

## Annex A (normative)

### Purification by anion-exchange separation

#### A.1 General

Test samples to be purified by anion exchange have been previously fumed to dryness in sulphuric acid. The methodology provided in [Annex A](#) is capable of achieving plutonium recoveries at or very near 100,00 %. A vacuum-assisted separation may be used to increase the flow rate during anion-exchange purification to reduce the elapsed time for the purification<sup>[19]</sup>.

Resin selection, capacity, and method implementation shall be shown by the user to provide a quantitative plutonium recovery (or a bias that is well defined may be appropriately included in the calculations and the uncertainty estimates).

#### A.2 Additional reagents and equipment for anion-exchange purification

**A.2.1 Resin**, analytical grade, quaternary amine on polystyrene resin, with 8 % cross-linkage and 3 milliequivalents per gram capacity, in nitrate-form, and stored in water (50 to 100 mesh for gravity feed and 200 to 400 mesh for vacuum-assisted extraction systems.)

**A.2.2 Ferrous sulphate heptahydrate (FeSO<sub>4</sub>·7H<sub>2</sub>O)**, 0,1 mol/L. Prepare by dissolving 1,0 g reagent-grade ferrous sulphate heptahydrate in 33 mL of distilled, demineralized water containing approximately 0,1 mL of concentrated sulphuric acid.

NOTE 1 An evaluation performed at AEA Technology, UK indicated that 20 % hydroxylamine hydrochloride is an effective substitute for ferrous sulphate heptahydrate, and has an advantage when neptunium is present. It reduces plutonium without reducing neptunium to the Np<sup>4+</sup> state, which loads on the anion exchange resin and follows plutonium through the purification<sup>[20]</sup>.

**A.2.3 Eluting solution**, 0,36 mol/L HCl and 0,01 mol/L HF. Prepare by diluting 30 mL of concentrated Hydrochloric and 0,4 mL of concentrated hydrofluoric reagent-grade acids into distilled, demineralized water to a volume of 1 L.

The corrosive properties of hydrochloric acid prevent some laboratories from using this dilute reagent. Method modifications to allow for alternative reagents shall be rigorously evaluated by the user for applicability, recovery percentage, and contribution to measurement precision.

NOTE 2 Measurements performed at AEA Technology, UK demonstrated recoveries of 99.96 % to 99.99 % for test samples containing 2 mg of plutonium, when eluting with three 2-mL portions of 1 mol/L sulphuric acid<sup>[20]</sup>.

**A.2.4 Columns**, nominal capacity 15 mL, tapered, with 6 mm to 8 mm inner radius.

**A.2.5 Vacuum-extraction system or equivalent**, with appropriate racks for coulometer cells.

#### A.3 Purification by anion-exchange separation

##### A.3.1 Procedure sequence

Dissolve each of the dry plutonium residues in 8 mL of 0,9 mol/L nitric acid.

Add 3 mL of 0,1 mol/L ferrous sulphate solution to each plutonium solution and swirl to mix.

Add 10 mL of concentrated nitric acid to each plutonium solution and swirl to mix.

If an excess of  $\text{NO}_2^-$  is added to the 7,8 mol/L  $\text{HNO}_3$  anion-exchange load solution and the solution heated at 70 °C to 80 °C for 10 min, the neptunium should be oxidized selectively, and the fraction of the neptunium retained on the anion-exchange column reduced significantly.

Prepare one anion-exchange column for each test sample and standard to be separated, by adding 4 mL of nitrate-form anion-exchange resin to each column and acidifying with 15 mL of 8 mol/L nitric acid.

Load each of the test samples on an anion-exchange column.

Wash the impurities from the column using 25 mL to 30 mL of 8 mol/L nitric acid, delivered in 3 mL to 5 mL portions that are allowed to drain between portions. Use the first three or four portions to wash out the test sample beaker and transfer the wash to the column.

Under each column, place a clean coulometry cell containing 1 mmol to 2 mmol of sulphuric acid (1 or 2 drops of concentrated sulphuric acid).

Elute the purified plutonium using 15 mL to 20 mL of a mixture of 0,36 mol/L hydrochloric acid and 0,01 mol/L hydrofluoric acid, delivered in 3 mL to 5 mL portions.

Rinse the tip of each column with a few drops of eluting solution into each corresponding cell.

Add 3 mol/L sulphuric acid to each cell then evaporate the solution of purified plutonium to a dry plutonium sulphate residue.

If desired, redissolve the plutonium residue in 3 mol/L sulphuric acid and repeat the evaporation to dryness.



## Annex B (normative)

### Determination of formal potential, $E_0$

#### B.1 Basic method

The formal potential  $E_0$  for the  $\text{Pu}^{4+}/\text{Pu}^{3+}$  couple in the 0,9 mol/L nitric acid can be determined immediately after a coulometric assay of pure plutonium.

- Carry out the procedure specified in [Clause 7](#). After completion of the steps described in [7.1.7](#), stop the electrolysis, keep on stirring and maintain the gas flow.
- Preset the reduction potential at + 0,400 V (SCE) and the oxidation potential at + 0,460 V (SCE).
- Start the reduction at + 0,400 V (SCE) and reduce until a residual current lower than 1  $\mu\text{A}$  is obtained.
- Reset the integrator.
- Start the oxidation at + 0,460 V (SCE) and oxidize until a residual current lower than 1  $\mu\text{A}$  is obtained.
- Record the integrated current and the corresponding potential.
- Increase, step by step, the oxidation potential value up to + 0,840 V (SCE). For each 0,02 V step, oxidize until a residual current lower than 1  $\mu\text{A}$  is obtained. Then record the integrated current  $Q$  and the corresponding potential  $E_{\text{ox}}$ .
- Plot the curve  $Q = f(E_{\text{ox}})$  and calculate the redox formal potential of the  $\text{Pu}^{4+}/\text{Pu}^{3+}$  couple in 0,9 mol/L nitric acid by the differential or the Fortiun method modified by Wolf[21][22].

The  $E_0$  value obtained is valid only with the reference electrode used for the measurement.

If the discrepancy between two determinations of  $E_0$  is greater than 10 mV, evaluate or change the reference electrode.

#### B.2 Alternate method

As an alternative the formal potential may be determined by first measuring the total plutonium in a test sample or standard, then repeating the electrolysis until half of the plutonium has been oxidized. The electrolysis is halted at 50 % complete by adjusting the control potential until it matches the solution potential, as evidenced by the electrolysis current being approximately zero (<10  $\mu\text{A}$ ). At this point, the solution potential,  $E_S$ , is equal to the formal potential. If the electrolysis is not halted at exactly 50 %  $\text{Pu}^{4+}/50$  %  $\text{Pu}^{3+}$ , the formal potential,  $E_0$ , may be calculated as follows:

$$E_0 = E_S - \frac{RT}{nF} \ln (\% \text{Pu}^{4+} / \% \text{Pu}^{3+}) \quad (\text{B.1})$$

This correction is very small when the concentrations of  $\text{Pu}^{4+}$  to  $\text{Pu}^{3+}$  are close. For example, for a 51/49 mixture, the correction is 0,001 V.

In principle, the formal potential could also be determined by generating a voltage-versus-current curve using a very small working electrode. However, this methodology was not tested during method evaluation.

## Bibliography

- [1] MEITES L., & MOROS S.A. *Anal. Chem.* 1959, **31** p. 25
- [2] HOLLAND M.K., WEISS J.R, PIETRI C.E *Anal. Chem.* 1978, **50** p. 236
- [3] HOLLAND M.K., & CORDARO J.V., U.S. Department of Energy Publication DP-1751, "An Automated Instrument for Controlled-Potential Coulometry: System Documentation, (June 1988), Savannah River Site, P. O. Box 616, Aiken, SC, 29808, USA
- [4] HOLLAND M.K., CORDARO J.V., , FIELDS T.C, REEVES G.E. "Automated Controlled-Potential Coulometer for the IAEA," Proceedings from the 6th International Conference on Nuclear Engineering, San Diego, California, USA, May 10-14, 1998
- [5] HOLLAND MICHAEL K., & CORDARO JOSEPH V. *Radioanal. Nucl. Chem.* 2009, **282** pp. 555–563
- [6] MOHR P.J., TAYLOR B.N., NEWELL D.B. *Journal of Physical and Chemical Reference Data*, (2008), Vol. 37, No.3, pp.1187-1284 (2008)<sup>1)</sup>
- [7] MOHR P.J., TAYLOR B.N., NEWELL D.B. Review of Modern Physics ( 2008), Vol.80, No.2, pp. 633-730<sup>1)</sup>
- [8] ANSI N15.41-1984, R1994, *Derivation of Measurement Control Programs – General Principles*
- [9] ANSI N15.51-1990, R2007, *Nuclear Materials Management — Measurement Control Programs – Nuclear Materials Analytical Chemistry Laboratory*
- [10] ISO 17025, *General requirements for the competence of testing and calibration laboratories*
- [11] JCGM 100:2008<sup>2)</sup>, *Evaluation of measurement data — Guide to the expression of uncertainty in measurement*
- [12] WIESER MICHAEL E., & COPLEN TYLER B. *Pure Appl. Chem.*, (2011) 83-2:359–396<sup>3)</sup>
- [13] PIETRI C.E, FREEMAN B.P, WEISS J.R U.S. Department of Energy Publication NBL-298, "The Quantitative Ion Exchange Separation of Plutonium from Impurities," (September 1981), U.S. Department of Energy, New Brunswick Laboratory, 9800 S. Cass Avenue, Argonne, Illinois, 60539, USA
- [14] MITCHELL W.G., SPALETTO M.I, LEWIS K, SORIANO M.D., SMITH M.M., U.S. Department of Energy Publication NBL-323, "The Effects of Ion Exchange Purification on the Determination of Plutonium at the New Brunswick Laboratory," (July 1990), U.S. Department of Energy, New Brunswick Laboratory, 9800 S. Cass Avenue, Argonne, Illinois, 60539, USA
- [15] ISO/IEC 80000 (all parts), *Quantities and units*
- [16] ISO 12803, *Representative sampling of plutonium nitrate solutions for determination of plutonium concentration*
- [17] HARRAR J.E., U.S. Atomic Energy Commission Publication UCRL-50417, "Platinum Working Electrode Cell for Controlled-Potential Coulometry," (March 27, 1968) University of California, Lawrence Livermore National Laboratory, Livermore, California, USA

---

1) References [6] and [7] are the work of the Committee on Data for Science and Technology (CODATA) for international use.

2) GUM 1995 with minor corrections.

3) Atomic weights of the elements (IUPAC Technical Report 2009)" © 2010 IUPAC, Publication date (Web): 12 December 2010. Sponsoring body: IUPAC Inorganic Chemistry Division, Commission on Isotopic Abundances and Atomic Weights.

- [18] HARRAR J.E., & SHAIN L. *Anal. Chem.* 1996, **38** p. 1148
- [19] MAXWELL S.L. *Radioactivity and Radiochemistry Journal.* 1998, **8** (4) p. 36
- [20] TUSHINGHAM R.W.A., MITCHELL C.R., FOSTER J.S. AEA Technology Report SRDP-R273, (December 2000), AEA Technology plc, 220, Harwell, Didcot, Oxfordshire, OX11 0QJ, UK
- [21] FORTIUN J.M.H *Anal. Chim. Acta.* 1961, **24** p. 175
- [22] WOLF S.Z *Anal. Chem.* 1970, **250** p. 13
- [23] ISO 10980, *Validation of the strength of reference solutions used for measuring concentrations*
- [24] ISO 3696, *Water for analytical laboratory use — Specification and test methods*





# British Standards Institution (BSI)

BSI is the national body responsible for preparing British Standards and other standards-related publications, information and services.

BSI is incorporated by Royal Charter. British Standards and other standardization products are published by BSI Standards Limited.

## About us

We bring together business, industry, government, consumers, innovators and others to shape their combined experience and expertise into standards-based solutions.

The knowledge embodied in our standards has been carefully assembled in a dependable format and refined through our open consultation process. Organizations of all sizes and across all sectors choose standards to help them achieve their goals.

## Information on standards

We can provide you with the knowledge that your organization needs to succeed. Find out more about British Standards by visiting our website at [bsigroup.com/standards](http://bsigroup.com/standards) or contacting our Customer Services team or Knowledge Centre.

## Buying standards

You can buy and download PDF versions of BSI publications, including British and adopted European and international standards, through our website at [bsigroup.com/shop](http://bsigroup.com/shop), where hard copies can also be purchased.

If you need international and foreign standards from other Standards Development Organizations, hard copies can be ordered from our Customer Services team.

## Copyright in BSI publications

All the content in BSI publications, including British Standards, is the property of and copyrighted by BSI or some person or entity that owns copyright in the information used (such as the international standardization bodies) and has formally licensed such information to BSI for commercial publication and use.

Save for the provisions below, you may not transfer, share or disseminate any portion of the standard to any other person. You may not adapt, distribute, commercially exploit, or publicly display the standard or any portion thereof in any manner whatsoever without BSI's prior written consent.

## Storing and using standards

Standards purchased in soft copy format:

- A British Standard purchased in soft copy format is licensed to a sole named user for personal or internal company use only.
- The standard may be stored on more than 1 device provided that it is accessible by the sole named user only and that only 1 copy is accessed at any one time.
- A single paper copy may be printed for personal or internal company use only.

Standards purchased in hard copy format:

- A British Standard purchased in hard copy format is for personal or internal company use only.
- It may not be further reproduced – in any format – to create an additional copy. This includes scanning of the document.

If you need more than 1 copy of the document, or if you wish to share the document on an internal network, you can save money by choosing a subscription product (see 'Subscriptions').

## Reproducing extracts

For permission to reproduce content from BSI publications contact the BSI Copyright & Licensing team.

## Subscriptions

Our range of subscription services are designed to make using standards easier for you. For further information on our subscription products go to [bsigroup.com/subscriptions](http://bsigroup.com/subscriptions).

With **British Standards Online (BSOL)** you'll have instant access to over 55,000 British and adopted European and international standards from your desktop. It's available 24/7 and is refreshed daily so you'll always be up to date.

You can keep in touch with standards developments and receive substantial discounts on the purchase price of standards, both in single copy and subscription format, by becoming a **BSI Subscribing Member**.

**PLUS** is an updating service exclusive to BSI Subscribing Members. You will automatically receive the latest hard copy of your standards when they're revised or replaced.

To find out more about becoming a BSI Subscribing Member and the benefits of membership, please visit [bsigroup.com/shop](http://bsigroup.com/shop).

With a **Multi-User Network Licence (MUNL)** you are able to host standards publications on your intranet. Licences can cover as few or as many users as you wish. With updates supplied as soon as they're available, you can be sure your documentation is current. For further information, email [subscriptions@bsigroup.com](mailto:subscriptions@bsigroup.com).

## Revisions

Our British Standards and other publications are updated by amendment or revision.

We continually improve the quality of our products and services to benefit your business. If you find an inaccuracy or ambiguity within a British Standard or other BSI publication please inform the Knowledge Centre.

## Useful Contacts

### Customer Services

**Tel:** +44 345 086 9001

**Email (orders):** [orders@bsigroup.com](mailto:orders@bsigroup.com)

**Email (enquiries):** [cservices@bsigroup.com](mailto:cservices@bsigroup.com)

### Subscriptions

**Tel:** +44 345 086 9001

**Email:** [subscriptions@bsigroup.com](mailto:subscriptions@bsigroup.com)

### Knowledge Centre

**Tel:** +44 20 8996 7004

**Email:** [knowledgecentre@bsigroup.com](mailto:knowledgecentre@bsigroup.com)

### Copyright & Licensing

**Tel:** +44 20 8996 7070

**Email:** [copyright@bsigroup.com](mailto:copyright@bsigroup.com)

### BSI Group Headquarters

389 Chiswick High Road London W4 4AL UK