

Plastics pipes and fittings — Equipment for fusion jointing polyethylene systems

Part 2: Electrofusion

ICS 23.040.20; 23.040.45; 75.200

National foreword

This British Standard is the UK implementation of ISO 12176-2:2008.

The UK participation in its preparation was entrusted to Technical Committee PRI/88/2, Plastics piping for pressure applications.

A list of organizations represented on this committee can be obtained on request to its secretary.

This publication does not purport to include all the necessary provisions of a contract. Users are responsible for its correct application.

Compliance with a British Standard cannot confer immunity from legal obligations.

This British Standard was published under the authority of the Standards Policy and Strategy Committee on 30 September 2008

© BSI 2008

ISBN 978 0 580 57287 6

Amendments/corrigenda issued since publication

Date	Comments

INTERNATIONAL STANDARD

ISO
12176-2

Second edition
2008-06-15

Plastics pipes and fittings — Equipment for fusion jointing polyethylene systems —

Part 2: Electrofusion

*Tubes et raccords en matières plastiques — Appareillage pour
l'assemblage par soudage des systèmes en polyéthylène —*

Partie 2: Électrosoudage



Reference number
ISO 12176-2:2008(E)

© ISO 2008

PDF disclaimer

This PDF file may contain embedded typefaces. In accordance with Adobe's licensing policy, this file may be printed or viewed but shall not be edited unless the typefaces which are embedded are licensed to and installed on the computer performing the editing. In downloading this file, parties accept therein the responsibility of not infringing Adobe's licensing policy. The ISO Central Secretariat accepts no liability in this area.

Adobe is a trademark of Adobe Systems Incorporated.

Details of the software products used to create this PDF file can be found in the General Info relative to the file; the PDF-creation parameters were optimized for printing. Every care has been taken to ensure that the file is suitable for use by ISO member bodies. In the unlikely event that a problem relating to it is found, please inform the Central Secretariat at the address given below.



COPYRIGHT PROTECTED DOCUMENT

© ISO 2008

All rights reserved. Unless otherwise specified, no part of this publication may be reproduced or utilized in any form or by any means, electronic or mechanical, including photocopying and microfilm, without permission in writing from either ISO at the address below or ISO's member body in the country of the requester.

ISO copyright office
Case postale 56 • CH-1211 Geneva 20
Tel. + 41 22 749 01 11
Fax + 41 22 749 09 47
E-mail copyright@iso.org
Web www.iso.org

Published in Switzerland

Contents

Page

Foreword.....	iv
1 Scope	1
2 Normative references	1
3 Terms and definitions.....	2
4 Designation of the different types of control unit	3
5 Construction requirements.....	3
5.1 General.....	3
5.2 Electrical safety.....	4
5.3 Cables	4
5.4 Cable connectors.....	4
5.5 Operator controls.....	5
5.6 Displays	5
5.7 Temperature-sensing element for fusion energy compensation	5
5.8 Input data decoder.....	5
5.9 Digital data output connectors.....	5
5.10 Transformers	6
5.11 Duty cycle	6
6 Operating procedures	6
6.1 Supply checks.....	6
6.2 Data input	7
6.3 Data validation	7
6.4 Fusion cycle	8
7 Operating requirements	8
7.1 General.....	8
7.2 Power supply.....	8
7.3 Coil resistance measurement/electrical continuity check.....	8
7.4 Energy output.....	9
7.5 Safety devices	9
7.6 Counter	10
7.7 Endurance	10
8 Mechanical performance.....	11
8.1 Shock resistance test	11
8.2 Vibration test	11
9 Technical file	11
10 Marking	12
Annex A (normative) Designation scheme	13
Annex B (informative) Duty cycle	16
Annex C (normative) Shock resistance test.....	17
Annex D (normative) Vibration test	18
Bibliography	19

Foreword

ISO (the International Organization for Standardization) is a worldwide federation of national standards bodies (ISO member bodies). The work of preparing International Standards is normally carried out through ISO technical committees. Each member body interested in a subject for which a technical committee has been established has the right to be represented on that committee. International organizations, governmental and non-governmental, in liaison with ISO, also take part in the work. ISO collaborates closely with the International Electrotechnical Commission (IEC) on all matters of electrotechnical standardization.

International Standards are drafted in accordance with the rules given in the ISO/IEC Directives, Part 2.

The main task of technical committees is to prepare International Standards. Draft International Standards adopted by the technical committees are circulated to the member bodies for voting. Publication as an International Standard requires approval by at least 75 % of the member bodies casting a vote.

Attention is drawn to the possibility that some of the elements of this document may be the subject of patent rights. ISO shall not be held responsible for identifying any or all such patent rights.

ISO 12176-2 was prepared by Technical Committee ISO/TC 138, *Plastics pipes, fittings and valves for the transport of fluids*, Subcommittee SC 4, *Plastics pipes and fittings for the supply of gaseous fuels*.

This second edition cancels and replaces the first edition (ISO 12176-2:2000), which has been technically revised.

ISO 12176 consists of the following parts, under the general title *Plastics pipes and fittings — Equipment for fusion jointing polyethylene systems*:

- *Part 1: Butt fusion*
- *Part 2: Electrofusion*
- *Part 3: Operator's badge*
- *Part 4: Traceability coding*

Plastics pipes and fittings — Equipment for fusion jointing polyethylene systems —

Part 2: Electrofusion

1 Scope

This part of ISO 12176 specifies performance requirements for electrofusion control units for use with polyethylene (PE) electrofusion fittings for the supply of gaseous fuels or for the conveyance of water for human consumption, including raw water prior to treatment, and for the conveyance of water for general purpose or other fluids.

The control units are divided into three input voltage classes: SVLV [safety, very low voltage (up to 50 V)], LV [low voltage (50 V to 250 V)] and HV [higher voltage (250 V to 400 V)].

This part of ISO 12176 is applicable to electrofusion control units designed for use in the construction of joints between PE pipes and fittings conforming to International Standards for the supply of gaseous fuels or for the conveyance of water, where the normal operating temperature of the control unit is in the range $-10\text{ }^{\circ}\text{C}$ to $+40\text{ }^{\circ}\text{C}$. If temperatures outside this range are expected, suitable operating limits are subject to agreement between manufacturer and purchaser.

This part of ISO 12176 is applicable to control units with current or voltage control for fitting systems based on standard resistance wire heating technology.

2 Normative references

The following referenced documents are indispensable for the application of this document. For dated references, only the edition cited applies. For undated references, the latest edition of the referenced document (including any amendments) applies.

ISO 13950, *Plastics pipes and fittings — Automatic recognition systems for electrofusion joints*

IEC 60068-2-27, *Environmental testing — Part 2-27: Tests — Test Ea and guidance: Shock*

IEC 60335-1, *Household and similar electrical appliances — Safety — Part 1: General requirements*

IEC 60335-2-45, *Household and similar electrical appliances — Safety — Part 2-45: Particular requirements for portable heating tools and similar appliances*

IEC 60529, *Degrees of protection provided by enclosures (IP Code)*

IEC 61558-1, *Safety of power transformers, power supplies, reactors and similar products — Part 1: General requirements and tests*

IEC 61558-2-6, *Safety of power transformers, power supply units and similar — Part 2: Particular requirements for safety isolating transformers for general use*

3 Terms and definitions

For the purposes of this document, the following terms and definitions apply.

3.1

operator

competent person entitled to assemble polyethylene pipes with electrofusion fittings

3.2

control unit

unit implementing the output fusion parameters of voltage or current and time or energy to execute the fusion cycle as specified by the electrofusion fitting manufacturer

NOTE Control units are classified with respect to electrical and process characteristics. Different types of control units are defined in 3.2.1 to 3.2.5.

3.2.1

preset control unit

control unit providing a stepped output power, preset by the manufacturer and generated at one or several selectable levels of voltage or current or energy or time

3.2.2

variable control unit

control unit providing a stepped output power generated from variable parameters defined from an external source

EXAMPLE Bar code, magnetic card.

3.2.3

multimode control unit

control unit providing a stepped output power generated at several levels of voltage and current and covering the energy input requirements of fittings from several manufacturers within the specification of each system, using at least one preset system associated with one variable system

3.2.4

multipurpose control unit

control unit providing a stepped or continuous output power generated at several levels of either voltage or current

3.2.5

universal control unit

control unit providing a stepped or continuous output power generated at several levels of both voltage and current coming from a variable system

3.3

data retrieval unit

any type of **control unit** (3.2) allowing the storage of the actual fusion data and permitting a read-out of these data

3.4

automatic control unit

any type of **control unit** (3.2) with automatic data input or fusion cycle control, where the **operator** (3.1) cannot alter the fusion parameters

3.5

control cycle

t

fixed period of time, composed of an on-load period, t_1 , and an off-load period, t_2 , i.e. the total time $t = t_1 + t_2$

**3.6
duty cycle**

t_d
proportion of the control cycle time, t , for which the output power is on load, t_1 , expressed as a percentage, i.e.
 $t_d = [t_1/(t_1 + t_2)] \times 100$

**3.7
output voltage**

output voltage value expressed as the root mean square (RMS) value (and not peak value)

**3.8
reference output voltage**

output voltage value at 75 % of the maximum output voltage of the control unit

**3.9
soft start**

stepped voltage increases over time periods of the order of seconds

4 Designation of the different types of control unit

The code letters in the designation of the types of control units are given in Table 1.

Table 1 — Code letters in the designation of the types of control units

Type of control unit	Code letter
Preset control unit (3.2.1)	Fifth code letter: F (see A.2.1)
Variable control unit (3.2.2)	Fifth code letter: V (see A.2.1)
Multimode control unit (3.2.3)	Fifth code letter: V (see A.2.1)
Multipurpose control unit (3.2.4)	Fifth code letter: V (see A.2.1)
Universal control unit (3.2.5)	Third code letter: W (see A.1.3) Fifth code letter: V (see A.2.1) Sixth code letter: A (see A.2.2)

5 Construction requirements

5.1 General

An electrofusion control unit can be a single unit or composed of several separate units. Therefore the control panel and the regulation system may or may not be integrated in a single unit.

Where the control unit is to be connected to a power generator, the manufacturer of the unit shall specify the input power requirements.

A portable control unit, with its frame (if supplied) and any associated input cable of at least 3 m included, shall not be heavier than 35 kg.

The control unit shall not start the fusion cycle if the fusion parameters introduced are out of the specified working range of the control unit.

The control unit should be designed to allow ease of readjustment and maintenance.

The control unit should be designed and constructed to allow its safe use in normal field conditions.

The control unit and its accessories should be designed to minimize the risk of corrosion or mechanical damage due to transport and handling in the field, which are likely to impair the performance of the control unit.

The control panel (e.g. keyboard, display) should be protected from impact damage during transport and handling.

5.2 Electrical safety

The control unit shall be protected in accordance with IEC 60529 such that the protection against direct contacts shall be at least to IP5X and the protection against the ingress of moisture shall be in accordance with class IPX4. All printed circuit boards shall be protected against the effects of condensation. No water shall lodge or accumulate in switches or buttons mounted on the control unit.

The control unit and its accessories shall fulfil the safety requirements specified in IEC 60335-1 and IEC 60335-2-45 and shall conform to national regulations, if any.

5.3 Cables

5.3.1 General

Input and output cables may be disconnectable or permanently connected. The cables shall remain flexible over the whole range of normal operating and storage conditions (i.e. $-10\text{ }^{\circ}\text{C}$ to $+40\text{ }^{\circ}\text{C}$).

A cable winding or storage facility shall be provided on the control unit.

Cables may require additional screening to satisfy the conditions required for safe operation of portable power supplies (i.e. isolated or earthed systems) and safety features fitted to the control unit.

5.3.2 Input cable

If a permanently attached input cable is provided, its nominal length shall be at least 3 m and a facility for input cable winding, storage and protection during transport shall be fitted to the control unit.

5.3.3 Output cable

The nominal length of the output cable(s) shall be at least 2,5 m.

The output cable(s) shall be suitable for the following functions:

- supply of electrical power to the fitting;
- sensing of the applied voltage and transmission of a feedback signal;
- supply and return of the identification voltage for the fitting verification procedure (resistance sensing).

5.4 Cable connectors

The connectors shall conform to the requirements given in IEC 60529 (see 5.2) for use in outside weather conditions.

The connectors shall have:

- a) a contact resistance as low as practicable;
- b) an ability to sense the applied voltage;
- c) facility of attachment;
- d) protection against direct human contact when connected to the fitting during the fusion cycle.

The connectors should be suitable for typical terminal connection to electrofusion fittings, as given in the relevant product standards, e.g. ISO 8085-3^[1].

5.5 Operator controls

The control unit shall at least have the following operator controls:

- a) a START button which shall be green;
- b) a RESET/STOP button, operation of which under any fault conditions shall cause at least a break in the output circuit;
- c) a STOP/ON-OFF switch, which shall be red and whose operation under any fault conditions shall directly cause a physical break in the input circuit.

If allowed by national regulations, control units without a STOP/ON-OFF switch can be used.

An overload protection device shall be fitted to the input side of the control unit.

5.6 Displays

All displays shall be clearly visible both in bright sunlight and in subdued light conditions.

5.7 Temperature-sensing element for fusion energy compensation

The control unit may be equipped with a temperature-sensing element for measurement of ambient temperature with an accuracy of ± 1 °C. The temperature-sensing lead may be fitted inside the control unit or externally for manual control by the operator. If fitted inside, it shall not be influenced by the heat produced by the control unit.

External temperature-sensing elements shall be protected from mechanical damage.

5.8 Input data decoder

The control unit shall be equipped with a decoder for reading the input data received from a manual keyboard or from an automatic system, e.g. using a terminal sensor, bar code or magnetic card.

Control units with an automatic fusion data recognition system as specified in ISO 13950 shall be programmed to allow decoding of such data.

It shall not be possible to introduce or modify the input data once the fusion cycle has started.

5.9 Digital data output connectors

5.9.1 General

The control unit may be equipped with a data retrieval unit which allows retrieval of stored fitting and fusion data. The data retrieval unit shall include the following components:

- a) a memory for storage of the data;
- b) an interface for data transmission (communication).

The control unit shall have a routine incorporated to facilitate data downloading.

5.9.2 Memory

The memory may be either an integral or removable part of the unit. The capacity of the memory shall allow a minimum storage of 250 fusion records.

A warning program may be included to prevent loss of data.

In case of memory overflow, the oldest data shall be deleted.

5.9.3 Interface

Units with data retrieval shall have an interface available to download the data stored in the memory to other electronic devices (e.g. personal computer, printer) for analysis and/or display and for storage.

The interface shall be a connector of a standard type (e.g. PCMCIA, serial port and/or parallel port), with or without an intermediate remote transmitter/receiver link.

5.9.4 Data protection

Control units with data retrieval shall include the following features to prevent loss of data:

- a) fusion data shall be recorded continuously during the fusion operation;
- b) in the event of interruption, the current fusion data shall remain available for control purposes;
- c) any data retrieval device fitted shall not operate if the memory unit is disconnected.

5.10 Transformers

All transformers shall be safety isolating transformers conforming to IEC 61558-1 and IEC 61558-2-6.

5.11 Duty cycle

For all control units with a classified output power up to and including 2 kW, the control cycle shall be 10 min. Thus, for a 60 % duty cycle (say), t_1 is equal to 6 min and t_2 is equal to 4 min.

For all control units with a classified output power greater than 2 kW, the control cycle shall be 15 min. Thus, for a 60 % duty cycle (say), t_1 is equal to 9 min and t_2 is equal to 6 min.

An example of a duty cycle is shown in Annex B. The graph is defined by the manufacturer for each control unit between 35 % and 100 % duty cycles at the reference output voltage, as defined in 3.8.

6 Operating procedures

6.1 Supply checks

When the checking system of the control unit verifies that the input voltage and frequency are within the permitted tolerance limits, these checks shall be indicated on a display. When the measured values are outside the tolerance limits, the control unit shall give an audible and/or visual warning signal and a display shall indicate the source of the fault.

6.2 Data input

6.2.1 Manual input

Units with manual data input shall be designed to introduce the process parameter(s) (voltage, current, time and/or energy) as applicable, namely:

- a) one of the parameters for preset control units (see 3.2.1);
- b) a combination of the parameters for multipurpose and universal control units.

Units with manual data input may be designed with a memory to allow a minimum storage capacity of six combinations of the details of the manufacturer/type/size of fitting; the choice of these combinations is usually based on an agreement between the purchaser and the manufacturer. The data input keyboard may also allow the introduction of the trade mark, the type of fitting (e.g. socket, saddle or reducer) and the diameter.

6.2.2 Automatic input

Control units provided with a system for automatic data input shall be able to decode data in accordance with ISO 13950.

Automatic input control units shall display the necessary information to permit the operator, if necessary, to check that the displayed information correspond to the type of fitting being connected.

6.3 Data validation

6.3.1 General

When the input of data is required to start the fusion process, means shall be incorporated to check if the data introduced correspond to the fitting being connected. This operation shall be done by the operator and/or the control unit.

If the check shows that the data introduced correspond to the fitting being connected, the data are accepted. If not, the control unit shall not start its fusion program and shall give a warning signal.

If any single part of the fusion program introduced cannot be implemented by the control unit, the fusion cycle shall be prevented from starting and the reason shall be displayed.

6.3.2 Data validation by the control unit

The control unit may be equipped with a system which checks the fitting being connected by measuring the resistance of the coil and comparing it with the data introduced, or the control unit may be fitted with another fitting identification system.

In the case of resistance measurement, the measured value may be displayed for verification purposes. If resistance measurement is used, the calculation shall be based on the resistivity of the coil material (data in the memory of the control unit or data introduced together with the fusion parameters) and the measured ambient temperature.

6.3.3 Data validation by the operator

After displaying control data, the control unit shall require operators to indicate manually that they have validated the displayed information, by pressing either the START button or a separate ACCEPT button.

6.4 Fusion cycle

6.4.1 Fusion time and energy

All relevant information concerning time and energy shall be displayed during the fusion cycle.

6.4.2 Incidents during fusion cycle

Any break in the input or output circuit shall require a restart of the complete fusion procedure.

If there is any fault or interruption during the fusion cycle, the control unit shall display the reason in plain text or as an encoded message. Relevant information regarding the fusion cycle may also be displayed.

6.4.3 Optional programs and equipment

Control units may be provided with specific programs or equipment introducing obligatory steps which have to be carried out before the fusion cycle can be started, for instance:

- a) external devices for manual temperature measurement;
- b) operator identification;
- c) construction site information.

Control units may also be equipped with complementary programs which reduce the current peak at the beginning of the fusion cycle. In such cases, the total specified energy shall nevertheless be supplied to the fitting.

7 Operating requirements

7.1 General

The required accuracy of operation shall be maintained at maximum and minimum ambient temperature for at least 12 months without the need for adjustment of the control unit.

7.2 Power supply

The control unit shall be capable of operating satisfactorily from a mains supply or from a generator.

Control units designed for use with portable generators shall, if possible, not be affected by harmonic distortion, inductance and reactance levels of the generator, which might affect its maximum power output.

The input voltage range shall be within $\pm 15\%$ of the nominal value.

The control unit manufacturer shall specify the operating frequency limits, indicating them either on the equipment or in the technical file (see Clause 9).

The manufacturer should provide information related to generator suitability of the control unit.

7.3 Coil resistance measurement/electrical continuity check

For control units fitted with resistance measurement equipment, the accuracy of this equipment shall be within $\pm 5\%$.

The control unit shall check the electrical continuity of the output circuit before allowing the fusion current to be switched on and fed to the fitting. The continuity-checking circuit shall be powered by a voltage which does not significantly heat up the coil but, in any case, shall not be higher than 24 V.

7.4 Energy output

7.4.1 Energy control

7.4.1.1 General

The control unit shall control either the voltage or the current during the fusion cycle, as specified in 7.4.1.2 or 7.4.1.3, to produce the required energy.

7.4.1.2 Voltage control

The output voltage shall be stabilized to within $\pm 1,5$ % of the nominal voltage value, but shall not exceed $\pm 0,5$ V.

The control unit shall use the voltage at the fitting, or in the transition plug, to control the voltage applied to the fitting.

Voltage-controlled control units may have a design transient current range of up to 100 A.

Including the progressive voltage increase steps, the required voltage shall be obtained within 1 % of the total fusion time, rounded up to the nearest whole second.

7.4.1.3 Current control

The output current shall be stabilized to within $\pm 1,5$ % of the nominal current value.

Including the progressive current increase steps or the soft start (see 3.9), the required current shall be obtained in less than 1 % of the total fusion time.

7.4.2 Cycle time

The cycle time shall be controlled to an accuracy of ± 1 % over the whole range of operating conditions.

7.4.3 Energy control

The total energy supplied to the fitting shall be controlled to an accuracy of ± 5 % over the whole range of operating conditions and taking into account, if necessary, ambient temperature compensation.

7.4.4 Power overload

The control unit shall be able to tolerate an overload of 10 % of the nominal power output (see Annex A) for at least 1 min.

7.5 Safety devices

7.5.1 General

All safety devices fitted shall remain operational during the complete fusion cycle. They shall interrupt the fusion cycle within the specified time and this shall be indicated on the display and on the data recorder, if present.

7.5.2 Obligatory safety devices

7.5.2.1 Output voltage or current

When the value of the output voltage or current exceeds $\pm 2\%$ of the selected value for more than 5 % of the nominal fusion time, with a maximum of 3 s, the fusion cycle shall be interrupted (not relevant for energy-controlled control units).

7.5.2.2 Break in output circuit

The control unit shall not operate when connected to a resistance above 200 Ω .

NOTE This is for operator safety reasons.

The control unit shall measure the electrical continuity across the voltage-sensing points at the fitting or in the transition plug. The continuity of this circuit shall be continuously monitored during the fusion cycle. If a break (open circuit) occurs in the output circuit, the control unit shall switch off in less than 1 s and a fault condition shall be indicated.

7.5.2.3 Stop switch

The fusion cycle shall be interrupted immediately on activation of the stop switch.

7.5.3 Optional safety devices

7.5.3.1 Input voltage

If the input voltage is outside the permitted limits (see 7.2) for more than 5 s, the fusion cycle shall be interrupted.

It is permissible to maintain the fusion cycle if the output voltage fulfils the required limits, even though the input voltage is outside the limit.

7.5.3.2 Frequency

If the frequency of the power supply is outside the permitted limits (see 7.2) for more than 5 s, the fusion cycle shall be interrupted.

7.5.3.3 Short circuit

In the event of a short circuit, the fusion cycle shall be interrupted. Thus any increase in current of, for instance, $> 10\%$ during any 4 s period shall cause the control unit to switch off.

7.6 Counter

The control unit may be equipped with a counter for recording or displaying the total number of fusion cycles.

7.7 Endurance

Following conditioning for 24 h at an ambient temperature of $(23 \pm 2)^\circ\text{C}$, the control unit shall operate for 1 h with a duty cycle of 60 % at $(23 \pm 2)^\circ\text{C}$, based on the duty cycle graph provided by the manufacturer of the control unit.

After testing, the control unit shall still meet the requirements of this part of ISO 12176.

8 Mechanical performance

8.1 Shock resistance test

The control unit with its frame (if supplied) shall be capable of withstanding the shock test given in IEC 60068-2-27 using the following conditions and in accordance with Figure C.1.

Shock level:	50g m/s ²
Pulse duration:	8 ms to 15 ms
Shock wave:	half-sine
Number of shocks:	three per axis along the X, -X, Y, -Y, Z, -Z axes (total 18 shocks)

After testing, the control unit shall still meet the requirements of this part of ISO 12176.

8.2 Vibration test

The control unit with its frame (if supplied) shall be capable of withstanding a vibration test using the following conditions and in accordance with Figures D.1 and D.2.

Vibration level:	2,186 RMS (average acceleration)
Frequency:	1,25 Hz to 10 Hz, +20 dB/oct 10 Hz to 20 Hz, 0,1 g ² /Hz 20 Hz to 500 Hz, -4,2 dB/oct
Test duration:	10 min per axis (X, Y, Z); see Figure D.2 (test starts after the maximum level is reached)

After testing, the control unit shall still meet the requirements of this part of ISO 12176.

9 Technical file

The manufacturer shall provide a technical file containing the following information:

- the designation of the control unit (see Annex A);
- simulation curves at 24 V output, if relevant, and at the reference output voltage;
- the duty cycle at 100 %, 60 % and 30 %.

The following additional information shall be provided either in the technical file or on the control unit:

- soft start;
- ambient temperature compensation;
- fitting temperature compensation;
- fusion data recorder.

10 Marking

The marking on the control unit shall include the following:

- manufacturer's identification;
- type of control unit;
- serial number;
- period of manufacture;
- designation (see Annex A);
- input voltage;
- input frequency;
- output power (single value) (see A.1.2).

Annex A (normative)

Designation scheme

NOTE Control units are classified with respect to their electrical and process characteristics. These characteristics are identified by eight code letters defined in Tables A.1 to A.8.

A.1 Electrical characteristics

A.1.1 Input voltage

Code letter No. 1: The input voltage is divided into three classes as defined in Table A.1.

Table A.1 — Designation with respect to the nominal input voltage

Code letter	P ₁	P ₂	P ₃
Definition	SVLV: safety, very low voltage (up to 50 V)	LV: low voltage (between 50 V and 250 V)	HV: higher voltage (between and 250 V and 400 V)

A.1.2 Output power

For designation purposes, the output power is defined at the reference voltage for a 60 % duty cycle. A single value shall be marked on the unit.

Code letter No. 2: The output power is divided into five classes as defined in Table A.2.

Table A.2 — Designation with respect to the output power

Code letter	1	2	3	4	5
Definition	>0 kW but ≤ 1 kW	>1 kW but ≤ 2 kW	>2 kW but ≤ 3 kW	>3 kW but ≤ 4 kW	> 4 kW

A.1.3 Control

Code letter No. 3: The type of control is divided into four classes as defined in Table A.3.

Table A.3 — Designation with respect to the type of output control

Code letter	U	I	E	W
Definition	Voltage control	Current control	Energy control	Voltage and current control

A.1.4 Output voltage

Code letter No. 4: The output voltage is divided into three classes as defined in Table A.4.

Table A.4 — Designation with respect to the output voltage

Code letter	S ₁	S ₂	S ₃
Definition	SVLV: safety, very low voltage (8 V to 42 V)	VLV: very low voltage (8 V to 84 V)	LV: low voltage (8 V to 250 V)

A.2 Process characteristics

A.2.1 Fusion parameters

Code letter No. 5: The fusion parameters are divided into two types as defined in Table A.5.

Table A.5 — Designation with respect to the fusion parameters

Code letter	F	V
Definition	Fixed fusion parameters	Variable fusion parameters

A.2.2 Data input

Code letter No. 6: The methods of data input are divided into two types as defined in Table A.6.

Table A.6 — Designation with respect to the method of data input

Code letter	K	A
Definition	Manual data input	Automatic data input

A.2.3 Data retrieval

Code letter No. 7: The inclusion of a data retrieval system is indicated as defined in Table A.7.

Table A.7 — Designation with respect to data retrieval

Code letter	D
Definition	Equipped with data retrieval system

A.2.4 Number of fitting trade marks

Code letter No. 8: The number of different fitting trade marks with which the control unit is compatible is indicated as defined in Table A.8.

Table A.8 — Designation with respect to the number of compatible fitting trade marks

Code letter	M	X
Definition	Single-purpose (one trade mark)	Multipurpose (several trade marks)

A.3 Complete designation

The complete designation of a control unit is as given in Table A.9.

Table A.9 — Complete designation

	Input voltage	Output power	Control	Output voltage	Fusion parameters	Data input	Data retrieval	Number of compatible fitting trade marks
Code letter (see tables above)	P ₁ or P ₂ or P ₃ See Table A.1	1 or 2 or 3 or 4 or 5 See Table A.2	U or I and/or E or W See Table A.3	S ₁ or S ₂ or S ₃ See Table A.4	F and/or V See Table A.5	K and/or A See Table A.6	D or "blank" See Table A.7	M or X See Table A.8

A.4 Examples of complete designations

P₂3UES₂VADX: Low voltage input (50 V to 250 V) — 3 kW — Voltage and energy control — Very low voltage output (8 V to 84 V) — Variable fusion parameters — Automatic data input — Data retrieval — Multipurpose

P₁3US₁VADX: Safety, very low voltage input (0 V to 50 V) — 3 kW — Voltage control — Safety, very low voltage output (8 V to 42 V) — Variable fusion parameters — Automatic data input — Data retrieval — Multipurpose

Annex B (informative)

Duty cycle

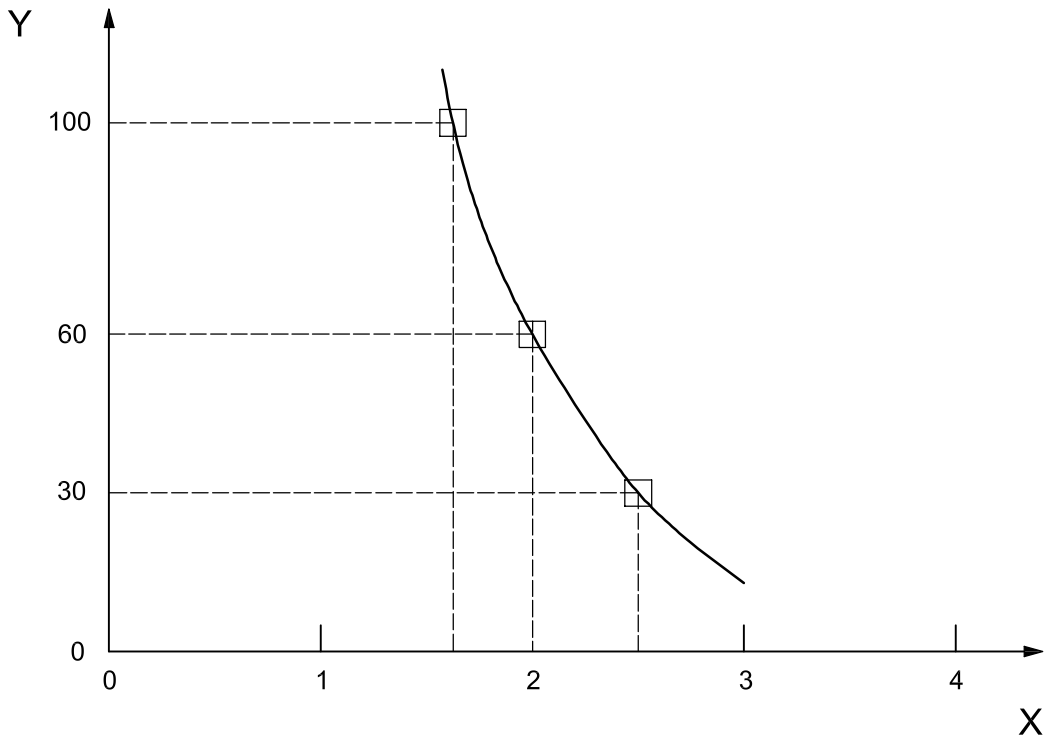

Key

- X output power at reference voltage, kW
- Y duty cycle, %

Figure B.1 — Example of duty cycle related to output power at reference voltage

Annex C (normative)

Shock resistance test

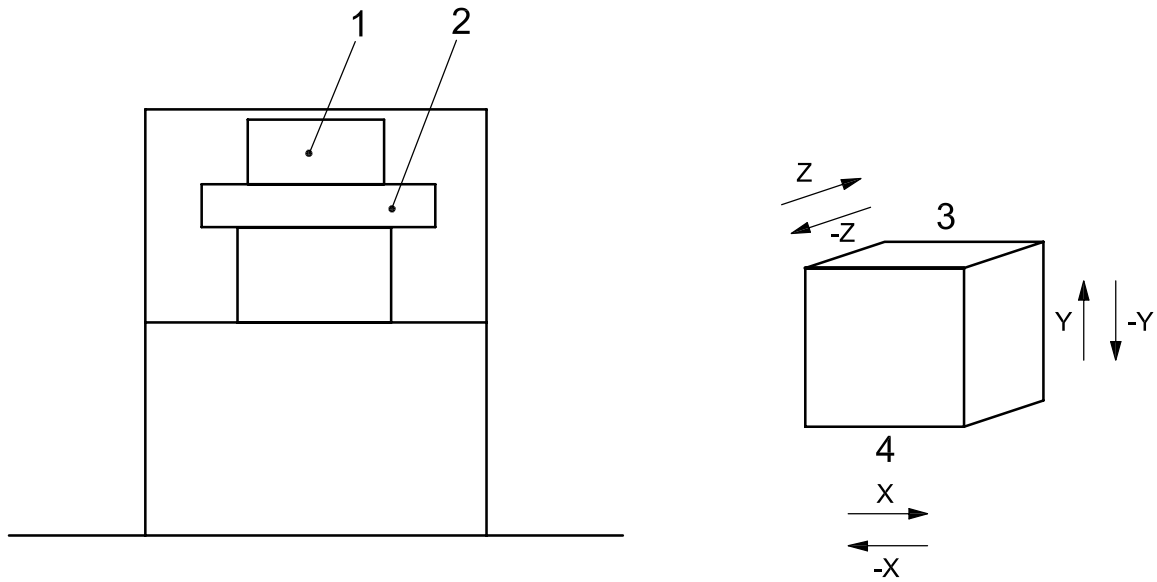

Key

- 1 control unit
- 2 anchorage
- 3 top
- 4 bottom

Figure C.1 — Shock test equipment

Annex D (normative)

Vibration test

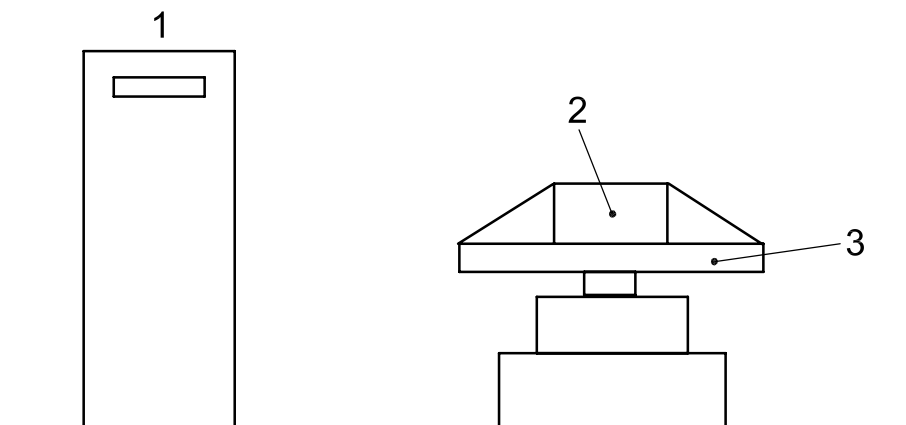

Key

- 1 generator
- 2 control unit
- 3 anchorage

Figure D.1 — Vibration test equipment

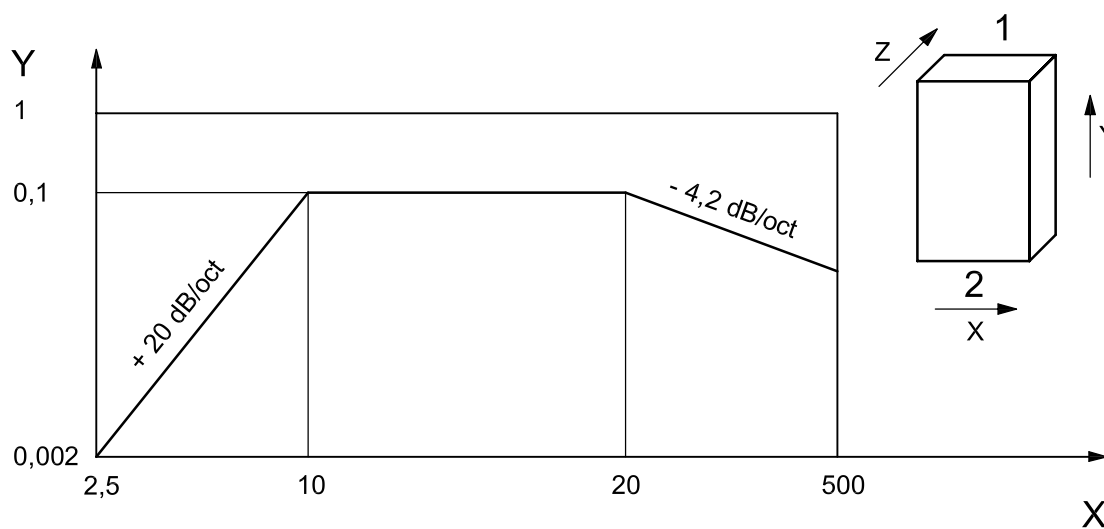

Key

- X frequency, Hz
- Y vibration intensity, g^2/Hz
- 1 top
- 2 bottom

Figure D.2 — Transport test

Bibliography

- [1] ISO 8085-3, *Polyethylene fittings for use with polyethylene pipes for the supply of gaseous fuels — Metric series — Specifications — Part 3: Electrofusion fittings*

ICS 23.040.20; 23.040.45; 75.200

Price based on 19 pages

BSI - British Standards Institution

BSI is the independent national body responsible for preparing British Standards. It presents the UK view on standards in Europe and at the international level. It is incorporated by Royal Charter.

Revisions

British Standards are updated by amendment or revision. Users of British Standards should make sure that they possess the latest amendments or editions.

It is the constant aim of BSI to improve the quality of our products and services. We would be grateful if anyone finding an inaccuracy or ambiguity while using this British Standard would inform the Secretary of the technical committee responsible, the identity of which can be found on the inside front cover. Tel: +44 (0)20 8996 9000. Fax: +44 (0)20 8996 7400.

BSI offers members an individual updating service called PLUS which ensures that subscribers automatically receive the latest editions of standards.

Buying standards

Orders for all BSI, international and foreign standards publications should be addressed to Customer Services. Tel: +44 (0)20 8996 9001. Fax: +44 (0)20 8996 7001 Email: orders@bsigroup.com You may also buy directly using a debit/credit card from the BSI Shop on the Website <http://www.bsigroup.com/shop>

In response to orders for international standards, it is BSI policy to supply the BSI implementation of those that have been published as British Standards, unless otherwise requested.

Information on standards

BSI provides a wide range of information on national, European and international standards through its Library and its Technical Help to Exporters Service. Various BSI electronic information services are also available which give details on all its products and services. Contact Information Centre. Tel: +44 (0)20 8996 7111 Fax: +44 (0)20 8996 7048 Email: info@bsigroup.com

Subscribing members of BSI are kept up to date with standards developments and receive substantial discounts on the purchase price of standards. For details of these and other benefits contact Membership Administration. Tel: +44 (0)20 8996 7002 Fax: +44 (0)20 8996 7001 Email: membership@bsigroup.com

Information regarding online access to British Standards via British Standards Online can be found at <http://www.bsigroup.com/BSOL>

Further information about BSI is available on the BSI website at <http://www.bsigroup.com>

Copyright

Copyright subsists in all BSI publications. BSI also holds the copyright, in the UK, of the publications of the international standardization bodies. Except as permitted under the Copyright, Designs and Patents Act 1988 no extract may be reproduced, stored in a retrieval system or transmitted in any form or by any means – electronic, photocopying, recording or otherwise – without prior written permission from BSI.

This does not preclude the free use, in the course of implementing the standard, of necessary details such as symbols, and size, type or grade designations. If these details are to be used for any other purpose than implementation then the prior written permission of BSI must be obtained.

Details and advice can be obtained from the Copyright and Licensing Manager. Tel: +44 (0)20 8996 7070 Email: copyright@bsigroup.com