



BSI Standards Publication

# Paints and varnishes — Determination of curing characteristics using a free damped oscillation method

Part 1: Start temperature of the  
curing reaction

**National foreword**

This British Standard is the UK implementation of ISO 12013-1:2012.

The UK participation in its preparation was entrusted to Technical Committee STI/10, Test methods for paints.

A list of organizations represented on this committee can be obtained on request to its secretary.

This publication does not purport to include all the necessary provisions of a contract. Users are responsible for its correct application.

© The British Standards Institution 2012.  
Published by BSI Standards Limited 2012.

ISBN 978 0 580 66517 2

ICS 87.040

**Compliance with a British Standard cannot confer immunity from legal obligations.**

This British Standard was published under the authority of the Standards Policy and Strategy Committee on 30 November 2012.

**Amendments issued since publication**

Date	Text affected
------	---------------

---

---

---

**Paints and varnishes — Determination  
of curing characteristics using a free  
damped oscillation method —**

Part 1:

**Start temperature of the curing reaction**

*Peintures et vernis — Détermination des caractéristiques de  
polymérisation par une méthode utilisant un pendule amorti —*

*Partie 1: Température de début de réaction de polymérisation*





**COPYRIGHT PROTECTED DOCUMENT**

© ISO 2012

All rights reserved. Unless otherwise specified, no part of this publication may be reproduced or utilized in any form or by any means, electronic or mechanical, including photocopying and microfilm, without permission in writing from either ISO at the address below or ISO's member body in the country of the requester.

ISO copyright office  
Case postale 56 • CH-1211 Geneva 20  
Tel. + 41 22 749 01 11  
Fax + 41 22 749 09 47  
E-mail [copyright@iso.org](mailto:copyright@iso.org)  
Web [www.iso.org](http://www.iso.org)

Published in Switzerland

## Contents

Page

<b>Foreword</b> .....	<b>iv</b>
<b>Introduction</b> .....	<b>v</b>
<b>1 Scope</b> .....	<b>1</b>
<b>2 Normative references</b> .....	<b>1</b>
<b>3 Terms and definitions</b> .....	<b>1</b>
<b>4 Principle</b> .....	<b>2</b>
<b>5 Pendulum-damping apparatus</b> .....	<b>2</b>
<b>6 Sampling</b> .....	<b>6</b>
<b>7 Test panels</b> .....	<b>6</b>
<b>7.1 Substrate</b> .....	<b>6</b>
<b>7.2 Preparation and coating</b> .....	<b>6</b>
<b>7.3 Thickness of coating</b> .....	<b>7</b>
<b>8 Procedure</b> .....	<b>7</b>
<b>9 Expression of results</b> .....	<b>8</b>
<b>10 Precision</b> .....	<b>8</b>
<b>10.1 General</b> .....	<b>8</b>
<b>10.2 Repeatability limit</b> .....	<b>8</b>
<b>10.3 Reproducibility limit</b> .....	<b>8</b>
<b>11 Test report</b> .....	<b>8</b>
<b>Annex A (informative) Selection of pendulum and knife edge</b> .....	<b>9</b>
<b>Bibliography</b> .....	<b>10</b>

## Foreword

ISO (the International Organization for Standardization) is a worldwide federation of national standards bodies (ISO member bodies). The work of preparing International Standards is normally carried out through ISO technical committees. Each member body interested in a subject for which a technical committee has been established has the right to be represented on that committee. International organizations, governmental and non-governmental, in liaison with ISO, also take part in the work. ISO collaborates closely with the International Electrotechnical Commission (IEC) on all matters of electrotechnical standardization.

International Standards are drafted in accordance with the rules given in the ISO/IEC Directives, Part 2.

The main task of technical committees is to prepare International Standards. Draft International Standards adopted by the technical committees are circulated to the member bodies for voting. Publication as an International Standard requires approval by at least 75 % of the member bodies casting a vote.

Attention is drawn to the possibility that some of the elements of this document may be the subject of patent rights. ISO shall not be held responsible for identifying any or all such patent rights.

ISO 12013-1 was prepared by Technical Committee ISO/TC 35, *Paints and varnishes*, Subcommittee SC 9, *General test methods for paints and varnishes*.

ISO 12013 consists of the following parts, under the general title *Paints and varnishes — Determination of curing characteristics using a free damped oscillation method*:

- *Part 1: Start temperature of the curing reaction*
- *Part 2: Glass transition temperature*

## Introduction

A freshly applied coating dries and/or cures depending on its physical and chemical characteristics. There are “wet characteristics” of various substrates and the evaporation of the solvent in the drying/or curing process. The structure of the coating changes according to the drying or curing process of the coating. The start temperature of reaction is very important. It is essential to consider the evaporation of the solvent in the measurement of the start temperature of reaction.

- a) While a solvent evaporates, the curing of the coating begins. The evaporation of the solvent depends on:
  - 1) the evaporation behaviour of the solvents;
  - 2) the behaviour of the solvents in the coating film during each drying stage. This is affected by the boiling point.
- b) The evaporation characteristic of the solvents depends on the solubility and the thermal conductivity of the substrate.





# Paints and varnishes — Determination of curing characteristics using a free damped oscillation method —

## Part 1: Start temperature of the curing reaction

### 1 Scope

This part of ISO 12013 specifies a free damped oscillation method for determining the start temperature of the curing reaction of coatings.

### 2 Normative references

The following referenced documents are indispensable for the application of this document. For dated references, only the edition cited applies. For undated references, the latest edition of the referenced document (including any amendments) applies.

ISO 1513, *Paints and varnishes — Examination and preparation of test samples*

ISO 1514, *Paints and varnishes — Standard panels for testing*

ISO 2808, *Paints and varnishes — Determination of film thickness*

ISO 4618, *Paints and varnishes — Terms and definitions*

ISO 15528, *Paints, varnishes and raw materials for paints and varnishes — Sampling*

### 3 Terms and definitions

For the purposes of this document, the terms and definitions given in ISO 4618 and the following apply.

#### 3.1

##### **period**

absolute value of the time between two oscillations in the same direction of the free damping oscillation

#### 3.2

##### **logarithmic damping ratio**

$\Delta$

logarithm of the ratio between consecutive amplitudes of a free damped oscillation

#### 3.3

##### **crosslinking temperature**

$T_{cl}$

temperature at which the logarithmic damping ratio starts to increase rapidly and the period of oscillation starts to decrease rapidly

NOTE Figure 1 shows a study diagram from which the crosslinking temperature can be deduced (labelled 1).

#### 3.4

##### **start temperature of reaction**

temperature at which the logarithmic damping ratio begins to increase

NOTE The start temperature of reaction is shown in Figure 1 (labelled 2).

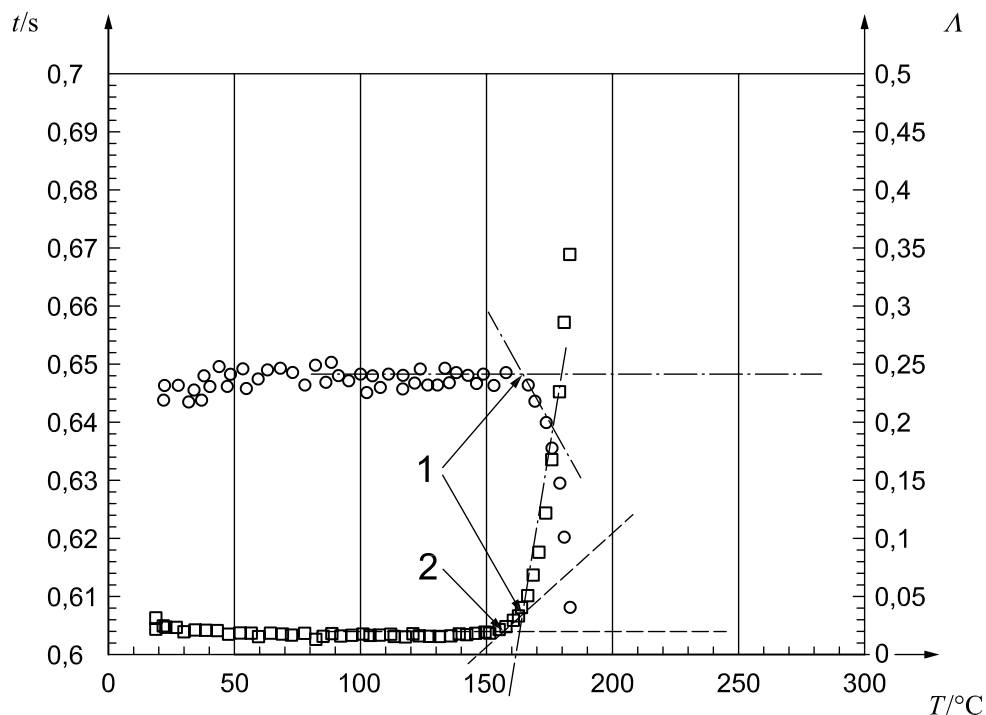

**Key**

$t$	period of oscillation	1	crosslinking temperature and network formation
$\Delta$	logarithmic damping ratio	2	start temperature of reaction
$T$	temperature	O	period of oscillation
		□	logarithmic damping ratio

**Figure 1 — Temperature dependence of the logarithmic damping ratio**

## 4 Principle

A coating is applied to a test panel. The coated panel is fixed in the apparatus and a rigid-body pendulum with a knife edge is lowered on to the coating. The heating rate and the amplitude of the first pendulum oscillation are set. The pendulum is released and allowed to oscillate. As the coating starts to dry or cure, the logarithmic damping ratio increases and the amplitude of oscillation of the pendulum becomes progressively smaller. The damping ratio is determined from measurements of the amplitude of the oscillation of the pendulum and plotted against the temperature. The point at which the logarithmic damping ratio begins to increase rapidly is recorded as the start temperature of reaction.

## 5 Pendulum-damping apparatus

**5.1 General.** Figure 2 shows an example of a pendulum-damping apparatus. In addition to the pendulum itself, the apparatus includes an electromagnet with which the required oscillation can be generated, a temperature-controlled test block, and a displacement sensor that detects each swing of the pendulum. The swings of the pendulum, the time that elapses from the beginning of the first oscillation and the temperature of the coating are monitored electronically.

**5.2 Temperature-controlled test block,** shown in Figure 3. The coated test panel is mounted on a mounting table (A), the temperature of which is regulated by means of an electric heating current passing through the block from B.

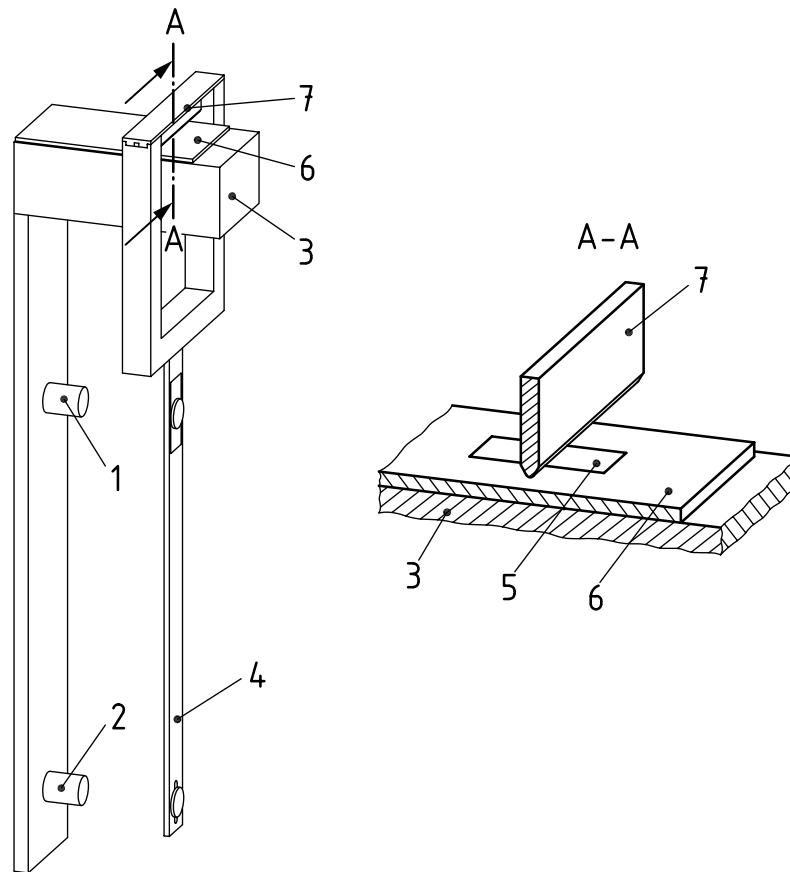

**Key**

- |   |                                   |   |            |
|---|-----------------------------------|---|------------|
| 1 | displacement sensor               | 5 | coating    |
| 2 | electromagnet                     | 6 | test panel |
| 3 | temperature-controlled test block | 7 | knife edge |
| 4 | rigid-body pendulum               |   |            |

**Figure 2 — Pendulum-damping apparatus**

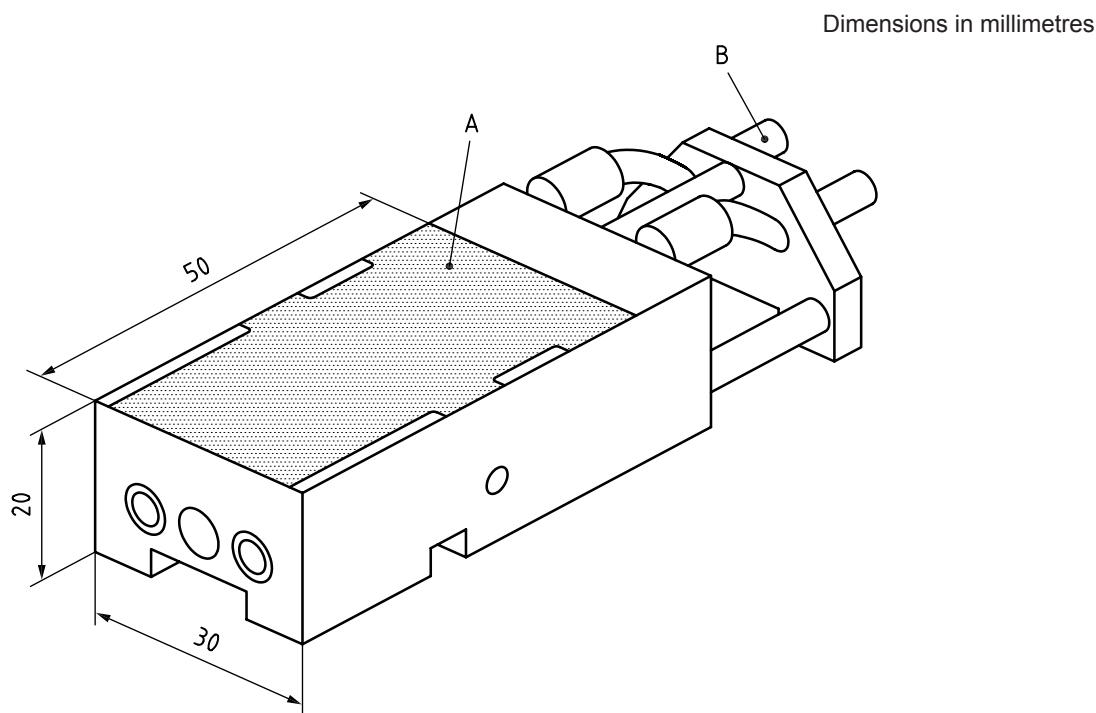

**Key**

A mounting table for test panel

B connection for electric-power supply

**Figure 3 — Temperature-controlled test block**

**5.3 Rigid-body pendulum**, of which Figure 4 shows the dimensions of two different types. These pendulums are designed so that their oscillation is generated by an electromagnet. The period and amplitude of oscillation are recorded automatically by a computer.

NOTE Guidance on the selection of the pendulum is given in Annex A.

**5.4 Knife edge**, attached to the pendulum and placed in contact with the coated test panel at the beginning of the test. The shape and dimensions of the knife edge are shown in Figure 5.

NOTE Guidance on the selection of the knife edge is given in Annex A.

Dimensions in millimetres

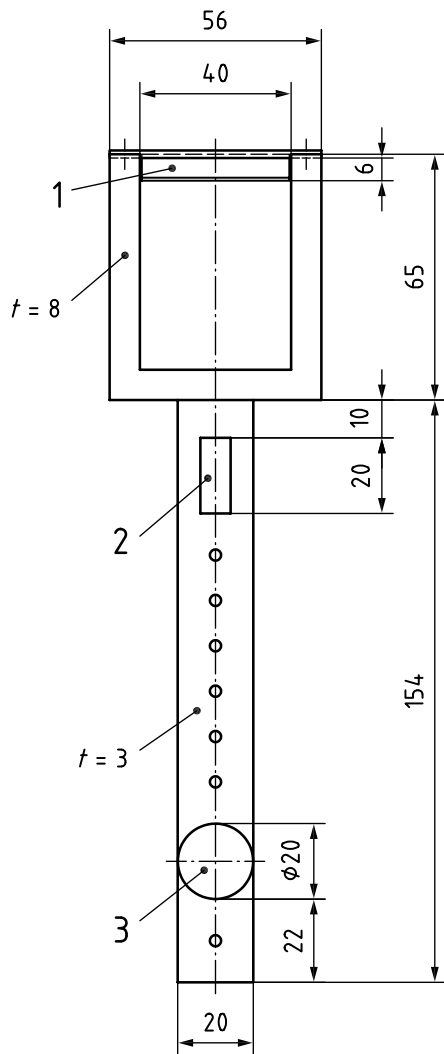

a) Type 1, steel, mass 51 g

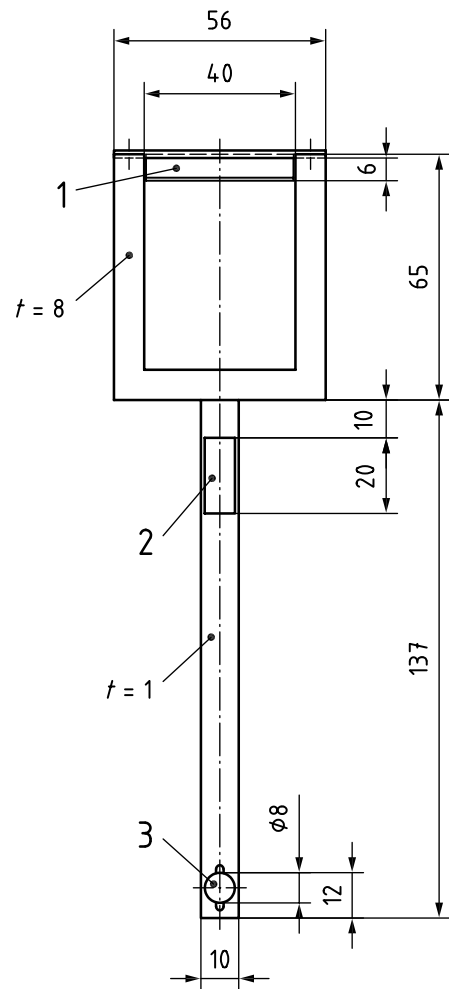

b) Type 2, steel, mass 45 g

**Key**

1 knife edge

2 displacement sensor

3 electromagnet

**Figure 4 — Rigid-body pendulum**

Dimensions in millimetres

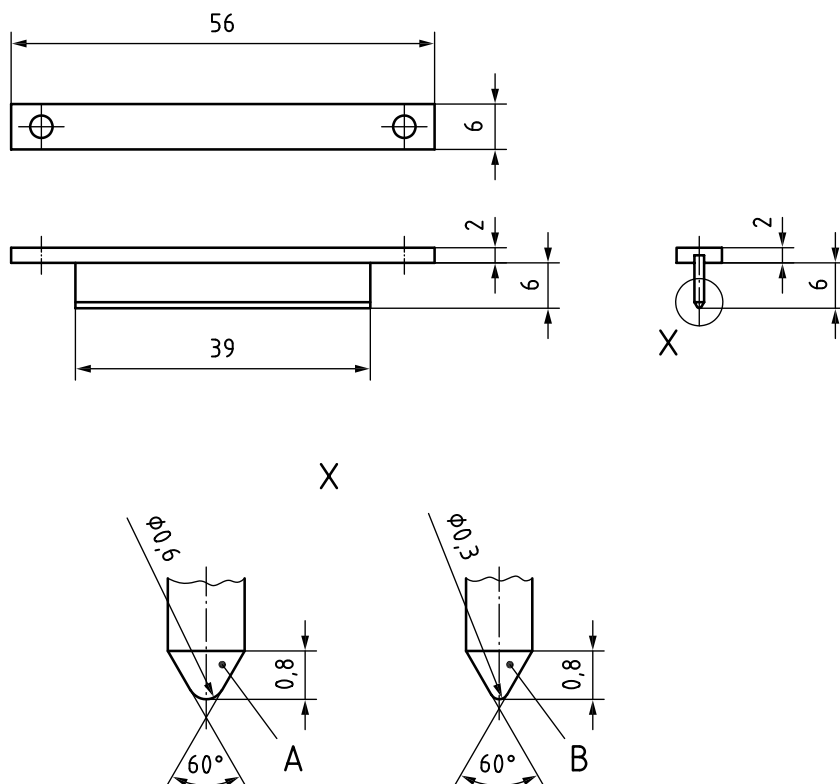

**Key**

- A knife edge A, material steel, mass 6 g, see Annex A
- B knife edge B, material steel, mass 6 g, see Annex A

**Figure 5 — Dimension of knife edge**

**6 Sampling**

Take a representative sample of the product to be tested (or of each product in the case of a multicoat system), as specified in ISO 15528.

Examine and prepare each sample for testing as specified in ISO 1513.

**7 Test panels**

**7.1 Substrate**

Select the substrate from those specified in ISO 1514, ensuring that the panels are planar and rigid. Metal, glass or plastic panels are recommended, with dimensions of 25 mm × 50 mm × (0,3 mm to 1,0 mm).

**7.2 Preparation and coating**

Prepare each test panel in accordance with ISO 1514 and then coat it with the product under test by using the draw-down method. The direction of application shall be as indicated by the arrow in Figure 6. The test coating shall be smooth and free from surface irregularities.

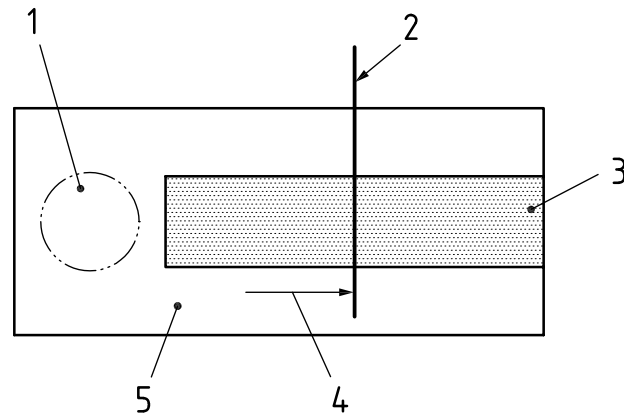

**Key**

- |   |                                |   |                                     |
|---|--------------------------------|---|-------------------------------------|
| 1 | position of temperature sensor | 4 | direction of application of coating |
| 2 | position of knife edge         | 5 | test panel (substrate)              |
| 3 | coating                        |   |                                     |

**Figure 6 — Test arrangement of temperature sensor, coating, and knife-edge**

### 7.3 Thickness of coating

After completion of the test, determine the thickness, in micrometres, of the dry coating, on a part of the test panel not affected by the test, by one of the procedures specified in ISO 2808.

## 8 Procedure

Carry out the determination in duplicate.

The starting temperature and the temperature increase are dependent not only on the type of coating and the substrate used, but also on the test conditions. The test conditions should preferably be agreed between the interested parties. If the conditions have not been agreed, a) to d) are recommended.

- Carry out the determination at a temperature of  $(23 \pm 2) ^\circ\text{C}$  and a relative humidity of  $(50 \pm 5) \%$ .
- Set the temperature at which the measurements are to begin to preferably  $30 ^\circ\text{C}$  and the heating rate to  $10 ^\circ\text{C}/\text{min}$ .
- Set the temperature at which the measurements are to finish to more than  $20 ^\circ\text{C}$  above the expected start temperature of the reaction.
- Measure the logarithmic damping ratio  $\Delta$  every 12 s. The oscillation of the rigid-body pendulum is performed at each reading interval. The time to draw a rigid-body pendulum to a magnet is 1 s to 2 s.

Immediately after the product under test has been applied to the test panel, place the coated test panel on the test block (5.2). Mount the temperature sensor on the upper surface of the test panel (see Figure 6) and record the temperature.

Place the knife edge, mounted on the pendulum, in contact with the coating on the test panel (see Figure 6). Start the apparatus.

During the test, the temperature of the test panel and the period of oscillation of the pendulum are recorded. The logarithmic damping ratio  $\Delta$  is calculated from the amplitude of oscillation of the pendulum and plotted against the temperature.

## 9 Expression of results

The starting temperature of reaction is taken to be the temperature, in degrees Celsius, at which the logarithmic damping ratio start to increase rapidly (see Figure 1). Calculate the mean of the values obtained in the two individual determinations and round this mean value to the nearest whole number.

## 10 Precision

### 10.1 General

Precision data for this method have been obtained with a melamine–polyester resin.

### 10.2 Repeatability limit

The repeatability limit  $r$  is the value below which the absolute difference between two single test results, each the mean of duplicates, can be expected to lie with a 95 % probability when this method is used under repeatability conditions (i.e. test results obtained on identical material by one operator in one laboratory within a short interval of time using the standardized test method). For the particular melamine–polyester resin tested,  $r$  has been found to be 4 °C.

### 10.3 Reproducibility limit

The reproducibility limit  $R$  is the value below which the absolute difference between two-single test results, each the mean of duplicates, can be expected to lie with a 95 % probability when this test method is used under reproducibility conditions (i.e. test results obtained on identical material by operators in different laboratories using the standardized test method). For the particular melamine–polyester resin tested,  $R$  has been found to be 20 °C.

## 11 Test report

The test report shall contain at least the following information:

- a) all details necessary for complete identification of the product tested (manufacturer, trade name, batch number, etc.);
- b) a reference to this part of ISO 12013 (ISO 12013-1:2012);
- c) details of the coated test panel (substrate material, film thickness, state of surface);
- d) the equipment and test conditions used (i.e. the type of rigid-body pendulum and knife edge, the temperature at which the test was begun, the heating rate, and the temperature at which the test was finished);
- e) the results of the test, including both the results of the individual determinations and their mean as specified in Clause 9;
- f) any specific agreements between the interested parties;
- g) any deviations from the procedure specified;
- h) any unusual features (anomalies) observed during the test;
- i) the date of the test.



## Annex A (informative)

### Selection of pendulum and knife edge

Table A.1 gives recommendations for the selection of the pendulum and the knife edge.

**Table A.1 — Selection of pendulum and knife edge**

Product under test	Type of knife edge	Type of pendulum
Thermosetting coatings		
Solvent-borne(oil-based) paints	A	2
Coating powders	A	2 or 1
Electrodeposition paints	B	1
Water-borne paints	A	2
Thick-film coatings ( $d > 100 \mu\text{m}$ )	A	1
Room-temperature-drying coatings		
Urethane paints	A	2
Lacquers	A	1
Thick-film coatings ( $d > 100 \mu\text{m}$ )	B	1

NOTE Shape of the edge:

Knife edge A 0,6 mm  $\varnothing$

Knife edge B 0,3 mm  $\varnothing$

## Bibliography

- [1] CHIU H.T., WU J.-H. A study on the curing behavior of silicone/polyurethane/epoxy blends by rigid-body pendulum rheometer. *Polym. Plast. Technol. Eng.* 2006, **45** pp. 1081–1085
- [2] TANAKA, T. Structure change and evaluation method in the curing process of coatings. 3rd Asia Coating Forum, 1990



---

---

**ICS 87.040**

Price based on 10 pages



# British Standards Institution (BSI)

BSI is the national body responsible for preparing British Standards and other standards-related publications, information and services.

BSI is incorporated by Royal Charter. British Standards and other standardization products are published by BSI Standards Limited.

## About us

We bring together business, industry, government, consumers, innovators and others to shape their combined experience and expertise into standards-based solutions.

The knowledge embodied in our standards has been carefully assembled in a dependable format and refined through our open consultation process. Organizations of all sizes and across all sectors choose standards to help them achieve their goals.

## Information on standards

We can provide you with the knowledge that your organization needs to succeed. Find out more about British Standards by visiting our website at [bsigroup.com/standards](http://bsigroup.com/standards) or contacting our Customer Services team or Knowledge Centre.

## Buying standards

You can buy and download PDF versions of BSI publications, including British and adopted European and international standards, through our website at [bsigroup.com/shop](http://bsigroup.com/shop), where hard copies can also be purchased.

If you need international and foreign standards from other Standards Development Organizations, hard copies can be ordered from our Customer Services team.

## Subscriptions

Our range of subscription services are designed to make using standards easier for you. For further information on our subscription products go to [bsigroup.com/subscriptions](http://bsigroup.com/subscriptions).

With **British Standards Online (BSOL)** you'll have instant access to over 55,000 British and adopted European and international standards from your desktop. It's available 24/7 and is refreshed daily so you'll always be up to date.

You can keep in touch with standards developments and receive substantial discounts on the purchase price of standards, both in single copy and subscription format, by becoming a **BSI Subscribing Member**.

**PLUS** is an updating service exclusive to BSI Subscribing Members. You will automatically receive the latest hard copy of your standards when they're revised or replaced.

To find out more about becoming a BSI Subscribing Member and the benefits of membership, please visit [bsigroup.com/shop](http://bsigroup.com/shop).

With a **Multi-User Network Licence (MUNL)** you are able to host standards publications on your intranet. Licences can cover as few or as many users as you wish. With updates supplied as soon as they're available, you can be sure your documentation is current. For further information, email [bsmusales@bsigroup.com](mailto:bsmusales@bsigroup.com).

## BSI Group Headquarters

389 Chiswick High Road London W4 4AL UK

## Revisions

Our British Standards and other publications are updated by amendment or revision.

We continually improve the quality of our products and services to benefit your business. If you find an inaccuracy or ambiguity within a British Standard or other BSI publication please inform the Knowledge Centre.

## Copyright

All the data, software and documentation set out in all British Standards and other BSI publications are the property of and copyrighted by BSI, or some person or entity that owns copyright in the information used (such as the international standardization bodies) and has formally licensed such information to BSI for commercial publication and use. Except as permitted under the Copyright, Designs and Patents Act 1988 no extract may be reproduced, stored in a retrieval system or transmitted in any form or by any means – electronic, photocopying, recording or otherwise – without prior written permission from BSI. Details and advice can be obtained from the Copyright & Licensing Department.

## Useful Contacts:

### Customer Services

**Tel:** +44 845 086 9001

**Email (orders):** [orders@bsigroup.com](mailto:orders@bsigroup.com)

**Email (enquiries):** [cservices@bsigroup.com](mailto:cservices@bsigroup.com)

### Subscriptions

**Tel:** +44 845 086 9001

**Email:** [subscriptions@bsigroup.com](mailto:subscriptions@bsigroup.com)

### Knowledge Centre

**Tel:** +44 20 8996 7004

**Email:** [knowledgecentre@bsigroup.com](mailto:knowledgecentre@bsigroup.com)

### Copyright & Licensing

**Tel:** +44 20 8996 7070

**Email:** [copyright@bsigroup.com](mailto:copyright@bsigroup.com)



...making excellence a habit.™