

Reaction to fire tests — Ignitability of building products subjected to direct impingement of flame —

Part 3: Multi-source test

ICS 13.220.50

National foreword

This British Standard reproduces verbatim ISO 11925-3:1997, including Technical Corrigendum 1:1998, and implements it as the UK national standard.

The UK participation in its preparation was entrusted by Technical Committee FSH/21, Reaction to fire tests, to Subcommittee FSH/21/2, Ignitability tests, which has the responsibility to:

- aid enquirers to understand the text;
- present to the responsible international/European committee any enquiries on the interpretation, or proposals for change, and keep the UK interests informed;
- monitor related international and European developments and promulgate them in the UK.

A list of organizations represented on this subcommittee can be obtained on request to its secretary.

The following errors have been identified in this document:

1. Page iv, Introduction, 4th paragraph, second line, replace “with” with “in”.
2. Page 3, clause 7.1 c) — replace “growing duration” with “varying in size and intensity with time”.
3. Page 16, Figure 5 — move arrow 1 to point to the next prong on the left. Delete item 1 in the Key.

Cross-references

The British Standards which implement international or European publications referred to in this document may be found in the BSI Standards Catalogue under the section entitled “International Standards Correspondence Index”, or by using the “Find” facility of the BSI Standards Electronic Catalogue.

A British Standard does not purport to include all the necessary provisions of a contract. Users of British Standards are responsible for their correct application.

Compliance with a British Standard does not of itself confer immunity from legal obligations.

Summary of pages

This document comprises a front cover, an inside front cover, pages i and ii, the ISO title page, pages ii to iv, pages 1 to 17 and a back cover.

This standard has been updated (see copyright date) and may have had amendments incorporated. This will be indicated in the amendment table on the inside front cover.

This British Standard, having been prepared under the direction of the Health and Environment Sector Board, was published under the authority of the Standards Board and comes into effect on 15 February 1998

© BSI 05-1999

Amendments issued since publication

| Amd. No. | Date | Comments |
|----------|---------------|---------------------------------------|
| 10297 | February 1999 | Indicated by a sideline in the margin |
| | | |
| | | |
| | | |

Contents

| | Page |
|---------------------|--------------------|
| National foreword | Inside front cover |
| Foreword | iii |
| Text of ISO 11925-3 | 1 |

INTERNATIONAL
STANDARD

ISO
11925-3

First edition
1997-06-15

**Reaction to fire tests — Ignitability
of building products subjected to direct
impingement of flame —**

**Part 3:
Multi-source test**

*Essais de réaction au feu — Allumabilité des produits du bâtiment soumis
à l'incidence directe de la flamme —*

Partie 3: Essai multi-sources



Reference number
ISO 11925-3:1997(E)

Contents

| | Page |
|--|------|
| Foreword | iii |
| Introduction | 1 |
| 1 Scope | 1 |
| 2 Normative reference | 1 |
| 3 Definitions | 2 |
| 4 Principle | 2 |
| 5 Safety requirements | 2 |
| 6 Ignition processes | 2 |
| 7 Characteristics of ignition sources | 3 |
| 8 Gas supply and regulation | 3 |
| 9 Ignition sources | 3 |
| 10 Specimens | 4 |
| 11 Test apparatus | 5 |
| 12 Testing room | 6 |
| 13 Conditioning and testing atmospheres | 6 |
| 14 Room ventilation | 6 |
| 15 Flame application times | 6 |
| 16 Test procedure | 7 |
| 17 Observations during testing | 8 |
| 18 Test report | 8 |
| Annex A (informative) Characteristics of ignition sources | 16 |
| Annex B (informative) Use by specifiers | 16 |
| Annex C (informative) Advice on testing end-use products | 16 |
| Annex D (informative) Bibliography | 17 |
| Figure 1 — Gas burner | 9 |
| Figure 2 — Burner for ignition sources E and F | 10 |
| Figure 3 — Test frame with draught shields | 11 |
| Figure 4 — Burner carriage | 12 |
| Figure 5 — Typical restraining comb for thermoplastic and flexible materials | 13 |
| Figure 6 — Surface ignition | 14 |
| Figure 7 — Bottom edge ignition | 15 |
| Table 1 — Specimen size and flame application times | 6 |

Descriptors: Buildings, fire protection, building components, construction materials, tests, fire tests, flammability testing, determination, ignitability.

Foreword

ISO (the International Organization for Standardization) is a worldwide federation of national standards bodies (ISO member bodies). The work of preparing International Standards is normally carried out through ISO technical committees. Each member body interested in a subject for which a technical committee has been established has the right to be represented on that committee. International organizations, governmental and non-governmental, in liaison with ISO, also take part in the work. ISO collaborates closely with the International Electrotechnical Commission (IEC) on all matters of electrotechnical standardization.

Draft International Standards adopted by the technical committees are circulated to the member bodies for approval before their acceptance as International Standards by the ISO Council. They are approved in accordance with ISO procedures requiring at least 75 % approval by the member bodies voting.

International Standard ISO 11925-3 was prepared by Technical Committee ISO/TC 92, *Fire safety*, Subcommittee SC 1, *Reaction to fire*.

ISO 11925 consists of the following parts under the general title *Reaction to fire tests — Ignitability of building products subjected to direct impingement of flame*:

- *Part 2: Single flame source test;*
- *Part 3: Multi-source test.*

Part 1 is under preparation.

Annex A to Annex D of this part of ISO 11925 are for information only.

Introduction

Fire is a complex phenomenon: its behaviour and effects depend upon a number of interrelated factors. The behaviour of materials and products depends upon the characteristics of the fire, the method of use of the materials and the environment in which they are exposed. The philosophy of “reaction to fire” tests is explained in ISO/TR 3814.

With the exception of rare cases of spontaneous ignition, for any fire to start, whether smouldering or flaming, it is essential for some form of ignition source to be applied to, or in some way contact, a product in such a way that continuing combustion can take place.

The ignition source can take three forms, something which imposes heat by conduction and/or radiation and/or convection. An example of ignition by conduction is by a hot wire coil or a hot metal bar; by radiation by an electric bar heater; and by convection by a convection heater or paint stripper. Usually, ignition sources of the radiative type include some degree of convection, and a flame includes a contribution from all three.

Recourse to various material fire statistics shows that many fires start from a range of common sources which vary in intensity and severity. Frequent sources of fire have been found to be as follows:

- i) Cooking appliances
- ii) Space heating
- iii) Electrical wiring and installations
- iv) Other electrical appliances
- v) Cigarettes and smokers materials (i.e. matches, lighters)
- vi) Blow lamps, etc.
- vii) Rubbish burning
- viii) Candles

A test such as is specified in this part of ISO 11925 deals only with a simple representation of a particular aspect of a potential fire situation typified by a flame playing directly onto a material, composite or assembly. It cannot alone provide any direct guidance on behaviour or safety in fire. A test of this type may, however, be used for comparative purposes or to ensure the existence of a certain quality of performance (in this case ignitability) considered to have a bearing on fire performance generally. It would be wrong to attach any other meaning to performance in this test.

The term “ignitability” is defined in ISO/IEC Guide 52 as the capability of a material of being ignited. It is one of the first fire properties to be manifest and should almost always be taken into account in any assessment of fire hazard. It may not, however, be the main characteristic of the material which affects the subsequent development of fire in a building.

This test does not rely upon the use of asbestos-based materials.

CAUTION — So that suitable precautions may be taken to safeguard health, the attention of all concerned in fire tests is drawn to the possibility that toxic or harmful gases may be evolved during exposure of test specimens. The advice on safety given in clause 5 should also be followed.

1 Scope

This part of ISO 11925 specifies a series of ignition sources which can be used for the determination of the ignitability of materials, composites and assemblies when subjected to direct impingement of flames of different size and intensity but without impressed irradiance. The sources may be used in isolation or with the test method specified.

This test method determines the ignitability of a material, composite or assembly and is not designed to assess any other fire parameter (e.g. flame spread). The possibility of the material composite or assembly causing secondary ignition of other materials is also considered by the observation of burning droplets or debris which may be formed.

NOTE Secondary ignition of material in a growing fire situation can be addressed using ISO 5657 which assesses the ignitability of building products by irradiance.

2 Normative reference

The following standard contains provisions which, through reference in this text, constitute provisions of this part of ISO 11925. At the time of publication, the edition indicated was valid. All standards are subject to revision, and parties to agreements based on this part of ISO 11925 are encouraged to investigate the possibility of applying the most recent editions of the standards indicated below. Members of IEC and ISO maintain registers of currently valid International Standards.

ISO/IEC Guide 52:1990, *Glossary of fire terms and definitions*.

3 Definitions

For the purposes of this part of ISO 11925, the definitions given in ISO/IEC Guide 52 and the following apply.

3.1

sustained ignition

after withdrawal of the ignition source, the presence of a flame on the surface of the specimen that persists for at least 4 s

3.2

transient ignition

after withdrawal of the ignition source, the appearance of flashes, or flames, which are not sustained for a continuous 4 s

3.3

progressive smouldering

an exothermic oxidation not accompanied by flaming which is self-propagating (i.e. independent of the ignition source) and may be accompanied by incandescence

3.4

flaming debris

matter flowing or separating from the specimen during the test procedure and falling below the initial lower edge of the specimen and continuing to flame as it falls

3.5

afterglow

persistence of glowing of a specimen, under specified test conditions, after cessation of flaming or, if no flaming occurs, after removal of the ignition source

3.6

flame application time

the time (in seconds) for which the burner is in its final testing position

3.7

constant mass

the state of a test specimen when two successive weighing operations, carried out at an interval of 24 h, do not differ by more than 0,1 % of the mass of the specimen or 0,1 g, whichever is the greater

4 Principle

Specimens are exposed to specified flames of different sizes and intensities and their ignition behaviour is observed. Annex C gives guidance on the application of this range of ignition sources to end-use products or specimens which are not essentially flat.

5 Safety requirements

There are hazards encountered when assessing the ignitability of any product using flame sources and it is essential that adequate precautions are taken. Particular attention should be paid to: the handling of flammable gases; the evolution of potentially toxic gases; and the fact that extensive flaming of specimens may occur.

The atmosphere of the testing room (see clause 12) may become hazardous and shall be cleared of smoke and toxic gases by an extractor fan or other means of ventilation.

Adequate means of extinguishing the specimen should be provided, bearing in mind that some specimens may produce severe flaming during the test. A hand and/or fixed water spray which can be directed over the burning area should be available with other means, such as fire extinguishers and fire blankets.

NOTE In some cases, smouldering may be difficult to extinguish completely and immersion in water may be necessary.

6 Ignition processes

6.1 When building products are exposed to thermal energy, flammable vapours may be generated from their surface. Under suitable conditions (especially in high temperatures), a critical concentration of flammable vapour may form and spontaneous ignition will result. If a flame is present as the sole energy source, or as a supplementary source, the ignition process will be assisted; this mechanism is sometimes known as pilot ignition.

6.2 A specimen of a building product is regarded as ignited when flames appear on its surface. Ignition from the sources detailed in this standard may be transitory or sustained.

6.3 After ignition has occurred, some burning materials create additional fire hazards by forming flaming debris or drips. If this flaming debris falls onto combustible material, secondary ignition may occur and the fire will spread more rapidly.

6.4 The localised application of a heat source to some materials may result in glowing combustion.

7 Characteristics of ignition sources

7.1 The main characteristics of ignition sources and their relation to the test specimen may be defined by the following factors.

- a) The intensity of the ignition source. This is a measure of the heat flux on the specimen resulting from the combined conduction, convection and radiation effects caused by the ignition source.
- b) The area of impingement of the ignition source on the specimen.
- c) The duration of exposure of the specimen and whether it is continuous, intermittent or varying in size and intensity with time.
- d) The presentation of the ignition source to the specimen and whether or not it impinges.
- e) The orientation of the specimen in relation to the ignition source.
- f) The ventilation conditions in the vicinity of the ignition source and exposed surface of the specimen.

7.2 Flame ignition sources

Two types have been selected.

7.2.1 Diffusion flame source

To form a diffusion flame source, gas (e.g. propane) flows through stainless steel tubes without ingress of air prior to the base of the flame.

NOTE These flames simulate natural flames well but they often fluctuate and are not convenient to direct if any angular presentation is required toward the specimen.

7.2.2 Premixed flame source

To form a premixed flame source, use a gas burner (e.g. using propane) fitted with air inlet ports or air intake manifold.

NOTE 1 Premixed flame sources are more directional than diffusion flame sources and are more suitable for some laboratory quality assurance tests.

NOTE 2 Premixed flame sources are generally hotter than diffusion flame sources.

8 Gas supply and regulation

A supply of commercial propane connected to the ignition sources by:

- a) a cylindrical regulator with an outlet pressure of 1 bar absolute;
- b) an appropriate length of 5 mm internal diameter high pressure hose;
- c) two flowmeters with integral needle valves and accuracies of $\pm 0,25$ %, with flow ranges covering 25 ml/min to 160 ml/min and 1 L/min to 10 L/min, connected to a common manifold top and bottom to allow measurement with either meter.

Some difficulties have been reported with the supply and measurement of the propane particularly where the propane cylinder has, of necessity, to be stored in an environment cooler than the defined test conditions and/or some distance from the test rig. In these cases, and other situations where difficulties occur, it is important that there is a sufficient length of tubing inside the controlled environment (10 °C to 30 °C) to ensure that the propane equilibrates to the required temperature before flow measurement. One way to assist this is to pass the propane (before flow measurement) through a metal tube immersed in water maintained at 25 °C.

Great care also needs to be exercised with the measurement and setting of the flow rate of the propane. Direct reading flow meters, even those obtained with a direct propane calibration, need to be checked when initially installed, and also at regular intervals during testing, with a method capable of measuring accurately the absolute propane flow at the burner tube. One way of doing this is to connect the burner tube with a short length of tubing (about 7 mm internal diameter) to a soap bubble flowmeter, such that the upward passage of a soap foil meniscus in a glass tube of calibrated volume (e.g. a burette) over a known period of time gives an absolute measurement of the flow. Fine control valves which can be preset to one of the desired propane flow rates, with simple switching means from one to the other, have also proved helpful.

9 Ignition sources

9.1 General

The following ignition sources provide a range of intensities and areas of impingement to be considered for use in fire tests involving building materials. The sources may be used in isolation or may be used with the test method and apparatus described in clause 11. The size of flame and its thermal characteristics for each of these ignition sources are detailed in Annex A.

9.2 Ignition source A

This consists of a burner consisting of a stainless steel tube bore of $0,5 \pm 0,1$ mm and with a minimum length of 35 mm.

NOTE 1 A hypodermic syringe, with the tapered end cut off square and cleanly, has been found suitable.

The flowmeter shall be calibrated to supply a propane gas flow rate at 25 °C of 25 ± 2 ml/min.

NOTE 2 This source provides a low intensity, low area diffusion flame and is used to simulate the effect of small flames resulting from fault conditions within electrical equipment.

9.3 Ignition source B (Kleinbrenner)

This consists of a burner constructed as shown in Figure 1. The burner consists of three parts, a gas jet, a burner tube and a flame stabilizer. The orifice diameter of the gas jet shall be $0,19 \pm 0,02$ mm. The burner tube shall consist of four zones, the air chamber, the gas mixing zone, the diffusion zone and the gas outlet within the air chamber. The burner tube shall have four air holes of 4 mm diameter for air inlets. The forward edge of the air holes shall be approximately level with the tip of the jet. The burner shall have a bore of 1,7 mm and an outlet of 3,0 mm inside diameter.

The flowmeter shall be calibrated to supply a propane gas flow rate at 25 °C of 25 ± 1 ml/min.

NOTE This source provides a low density premixed flame similar in calorific value to source C and its use is advantageous for tests where a small, stable, directable flame is required.

9.4 Ignition source C

This consists of a burner tube consisting of a length of stainless steel tube ($8,0 \pm 0,1$ mm outside diameter, $6,5 \pm 0,1$ mm internal diameter and 200 ± 5 mm in length). The flowmeter shall be calibrated to supply a propane gas flow rate at 25 °C of 45 ± 2 ml/min.

NOTE This diffusion flame has a calorific output approximately that of a burning match.

9.5 Ignition source D

This consists of a burner tube consisting of a length of stainless steel tube ($8,0 \pm 0,1$ mm outside diameter, $6,5 \pm 0,1$ mm internal diameter and 200 ± 5 mm in length). The flowmeter shall be calibrated to supply a propane gas flow rate at 25 °C of 160 ± 5 ml/min.

NOTE This diffusion flame has an intensity and area of impingement simulating that of a cigarette lighter.

9.6 Ignition source E

This consists of a gas burner comprising a 185 mm horizontal stainless steel tube (12,0 mm outside diameter, 9,0 mm inside diameter) closed at each end and fitted with a central gas pipe. The burner tube shall have a row of 14 holes of 1,5 mm diameter at 12,5 mm pitch, arranged so that the gas jets issue at an angle of 45° below the horizontal (see Figure 2). The flowmeter shall be calibrated to supply a propane gas flow rate at 25 °C of 2 L/min.

NOTE The heat output and area of impingement of flame simulates that of a burning crumpled newspaper.

9.7 Ignition source F

This consists of a gas burner comprising a 185 mm long horizontal stainless steel tube (12,0 mm outside diameter, 9,0 mm inside diameter) closed at each end and fitted with a central gas supply pipe. The burner tube shall have a row of 14 holes of 1,5 mm diameter at 12,5 mm pitch, arranged so that the gas jets issue at an angle of 45° below the horizontal (see Figure 2). The flowmeter shall be calibrated to supply a propane gas flow rate at 25 °C of 10 L/min.

NOTE This source simulates the flame produced by a flaming chip pan, 3 min after ignition of the cooking oil.

9.8 Ignition source G

This consists of a mild steel nickel plated burner (nominally 15,75 mm outside diameter, 13,5 mm internal diameter and 66 mm in length) with four pre-mixing air holes each nominally 20 mm × 3 mm and each nominally 40 mm from the burner end, and spaced equidistant from each other.

NOTE No flowmeter is required. This premixed source represents a plumbers blow torch. Under these conditions the flame height is approximately 110 mm.

9.9 Ignition source H

This consists of a mild steel nickel plated burner (nominally 38 mm outside diameter, 34 mm internal diameter and 98 mm in length) with 10 pre-mixing air holes each nominally 30 mm × 5 mm and each nominally 63 mm from the burner end, and spaced equidistant from each other.

NOTE No flowmeter is required. The premixed source is representative of a roofers torch. Under these conditions the flame height is approximately 230 mm.

10 Specimens

10.1 Dimensions

The dimensions of the specimens shall be as shown in Table 1 with a tolerance of $\begin{matrix} 0 \\ -5 \end{matrix}$ mm. In its usual form, the apparatus is able to accommodate specimens up to a maximum thickness of 50 mm. If thicker specimens are required to be tested, appropriate modifications to the specimen holder and rest position of the burner carriage shall be made.

10.2 Number and cutting

Take a minimum of six full thickness representative specimens for each ignition source to be applied and each flame application time (three for surface ignition and three for bottom ignition). If a material under test is asymmetric through its thickness, and in practice either face may be exposed to a source of ignition, test a separate series of specimens on each face. Similarly, for materials which are chemically or physically not uniform in any other plane, test by as many series of specimens as needed to represent the actual behaviour of the material when exposed to the various ignition sources.

Most composite materials and many homogenous ones are installed with covered edges and edge ignition tests shall be carried out on specimens of this form. If such materials may be used with unprotected edges they shall be tested in this form.

NOTE 1 To take an extreme example, a composite material with a grain/material direction and asymmetrical through its thickness, which could be installed with edges protected or otherwise, would require 8 sets of 3 specimens for bottom edge ignition and 4 sets of 3 specimens for face ignition, for each chosen ignition exposure in order to characterise its ignition behaviour.

Where materials will be fixed to substrates in practice, analogous procedures shall be used to prepare test specimens.

NOTE 2 Care is needed when preparing specimens for bottom edge exposure of materials applied to substrates since in practice the substrate may extend beyond the bottom of the material to be tested and not itself be subject to edge exposure. The configuration of the test specimen should reflect the practical aspects of such factors as type of substrate, fixing to substrate and presence and form of joints.

10.3 Suitability of a product for testing

10.3.1 An essentially flat product having one of the following characteristics is suitable for evaluation by this method:

- a) an essentially flat exposed surface;
- b) a surface irregularity that is evenly distributed over the exposed surface provided that:
 - i) at least 50 % of the surface of a representative square area of 250 mm × 250 mm lies within a depth of 6 mm from a plane taken across the highest points on the exposed surface; or
 - ii) for a surface containing cracks, fissures or holes which do not exceed 6,5 mm in width nor 10 mm in depth, the total area of such cracks, fissures or holes at the surface does not exceed 30 % of a representative square area of 250 mm × 250 mm of the exposed surface.

10.3.2 Where a product has areas of its surface which are distinctly different, but each of these separate areas can satisfy the surface characteristics described in **10.3.1**, then more than one test shall be conducted to fully evaluate the product.

10.3.3 When an exposed surface does not comply with the conditions of either item a) or b) of **10.3.1**, the product may be tested in a modified form with an essentially flat exposed surface and this shall be stated in the report.

11 Test apparatus

11.1 General

The test apparatus is designed to present each of the flame sources detailed in this part of ISO 11925 to the specimen in a smooth and repeatable manner. The apparatus consists of a specimen holder and mounting frame, and a burner carriage.

11.2 Test frame, comprising a horizontal steel platform to which a sliding burner carriage and burner tubes are attached. At one end of the platform, means shall be provided to maintain the specimen holder in a vertical position (see Figure 3).

NOTE Because of the corrosive conditions of testing and extinguishing, it is suggested that the frame be constructed of stainless steel.

11.3 Specimen holder, vertical, capable of accommodating the largest size of specimen. Specimens shall be gripped at intervals along both vertical edges.

For narrower specimens, holders may be designed to fit within the widest holder in order to provide a common position for testing.

11.4 Burner carriage and tube

The ignition source (see clause **10**) shall be mounted on a burner support tube fitted to the burner carriage (see Figure 4). The tube shall be equipped with means to allow vertical adjustment of the ignition source position as required by the various tests. The burner carriage shall be designed in such a way that the distance between the burner and the specimen is obtained accurately, reproducibility and automatically, and manufactured so that the ignition source can be brought into the prescribed position smoothly and within 1 s.

11.5 Timer, capable of being read to 0,1 s and preferably with a suitable audible warning device.

11.6 Restraining combs, two (see Figure 5), consisting of mild steel flat bars, 4 mm thick and 20 mm deep, through which prongs of mild steel, 2,5 mm thick and 300 mm long, are passed. One comb may be attached to the test frame via bolts and using wing nuts at a distance at least 75 mm below the specimen; the prongs on this comb shall be positioned at 100 mm pitch. The back comb shall be capable of being attached to the front comb using nuts and 60 mm long bolts; this comb shall have 5 prongs at 100 mm pitch and 50 mm from each end.

11.7 Draught shields, of 9 mm thick non-combustible board, triangular in shape, with a base of approximately 500 mm and approximately 750 mm in height, for use with ignition sources A, B and C. One shield shall be positioned on each side of the test frame and adjacent to it (see Figure 3).

12 Testing room

Use a room equipped with an extractor fan or other means of ventilation, capable of providing a substantially draught-free environment at between 10 °C and 30 °C and a relative humidity of 50 ± 20 %.

NOTE 1 It is recommended that the testing room be divided into two parts, the inner part for carrying out the tests and easily viewed from the outer part in which control equipment would be situated.

NOTE 2 It has been found that a partially darkened room assists with the perception of small surface flames.

For large ignition sources (of heat output more than 1 kW), either a testing room with a minimum volume of 20 m³ is required or, alternatively, a smaller enclosure with a through flow of air. If the latter is used it shall be equipped with inlet and extraction systems with air flow rates between 0,02 m/s and 0,2 m/s in the locality of the test specimen.

These limits provide adequate oxygen without disturbing the burning behaviour.

Testing with ignition sources A, B, C and D may be carried out in either of these environments, or in a suitable ventilated fume cupboard.

13 Conditioning and testing atmospheres

Before testing, the product to be tested shall be conditioned to constant mass at a temperature of 23 ± 2 °C and a relative humidity of 50 ± 5 %.

Testing shall be carried out in an atmosphere with a temperature of 20 ± 10 °C.

14 Room ventilation

Before any specimen or product is tested, ventilate the testing room or fume cupboard to ensure removal of combustion gases from previous tests then allow adequate time for air movement to reduce to the limits given in clause 12.

15 Flame application times

It is recommended that the flame application times as shown in Table 1 are used with this test method, for each of the ignition sources used in the test.

Table 1 — Specimen size and flame application times

| Ignition source | Specimen size (mm) | Flame application times (s) | | | |
|-----------------|-----------------------|--------------------------------|---|----|-----|
| | | 1 | 5 | 20 | 120 |
| A | 100 × 150 | 1 | 5 | 20 | 120 |
| B | 100 × 150 | 1 | 5 | 20 | 40 |
| C | 100 × 150 | 1 | 5 | 20 | 40 |
| D | 300 × 300 | 1 | 5 | 20 | 40 |
| E | 500 × 750 | — | 5 | 60 | 180 |
| F | 500 × 1 200 | — | 5 | 60 | 180 |
| G | 300 × 300 | 1 | 5 | 20 | 40 |
| H | 500 × 750 | — | 5 | 60 | 180 |

NOTE Whilst it is possible to test a product against the complete matrix of source and times it is recognised that a more economic approach would be to select a limited number of combinations

16 Test procedure

16.1 Specimen mounting

Mount a specimen in the specimen holder (11.3).

16.2 Restraining frame

With some materials, particularly those which are flexible at ambient temperature or which flex under the action of heat, it is necessary to restrain the larger specimens in order to maintain their surface at the specified distance from the burner tube orifice. This can be achieved by use of a restraining comb system as shown in Figure 5. The combs (11.6) clamp the specimen between their off-set prongs.

The procedure for their use is as follows:

- a) clamp the first comb to the test frame (Figure 5);
- b) mount the specimen in the test frame;
- c) clamp the second comb to the first comb so that the specimen is sandwiched between the prongs of the two combs (Figure 5);
- d) apply the ignition sources following the procedure given in 16.3 and 16.4 using a fresh specimen for each ignition source and flame application time.

16.3 Face ignition

16.3.1 Ignition sources A, B, C, D, E and F

Apply the flame from the ignition source to the face of the specimen at an angle of 45 degrees so that the axis of the burner is on the vertical centre line of the specimen, and 30 mm above the bottom edge, and the end of the burner tube is 5 mm from the face of the specimen [see Figure 6 a)]. Simultaneously start the clock. After the specified application time (see Table 1) remove the burner by withdrawing it smoothly from the specimen within 1 s.

Record for each specimen, for each ignition source and for each flame application time:

- a) whether a sustained ignition (greater than 4 s, see 3.1) or transient ignition (less than 4 s, see 3.2) occurs;
- b) whether debris separates and whether it is flaming or glowing;
- c) whether flaming (or glowing) reaches any edge within 4 s of the end of the flame application time;
- d) whether flaming (or glowing) reaches any edge during application of the ignition source.

16.3.2 Ignition sources G and H

Apply the flame from the ignition source to the face of the specimen at an angle of 90° so that the axis of the burner is on the vertical centre line of the specimen, and 150 mm (ignition source G) or 300 mm (ignition source H) above the bottom edge and the end of the burner tube is 90 mm (ignition source G) or 70 mm (ignition source H) from the face of the specimen [see Figure 6 b)]. Simultaneously start the clock. After the specified application time (see Table 1), remove the burner by withdrawing it smoothly from the specimen within 1 s.

Record for each specimen, for each ignition source and for each flame application time:

- a) whether a sustained ignition (greater than 4 s, see 3.1) or transient ignition (less than 4 s, see 3.2) occurs;
- b) whether debris separates and whether it is flaming or glowing;
- c) whether flaming (or glowing) reaches any edge within 4 s of the end of the flame application time;
- d) whether flaming (or glowing) reaches any edge during application of the ignition source.

16.4 Bottom edge ignition

Apply the flame from ignition sources A, B, C, D, E and F at an angle of 45° to the bottom edge of the specimen, with the end of the burner tube positioned 5 mm below the bottom edge and 5 mm from the face of the specimen as shown in Figure 7 a).

For ignition sources G and H, apply the flame to the bottom edge of the specimen at an angle of 90° to the specimen face and at a distance of 90 mm and 70 mm for ignition sources G and H respectively as shown in Figure 7 b). Simultaneously start the clock. After the specified application time (see Table 1) remove the burner by withdrawing it smoothly from the specimen within 1 s.

Record for each specimen, for each ignition source and for each flame application time:

- a) whether a sustained ignition (greater than 4 s, see 3.1) or transient ignition (less than 4 s, see 3.2) occurs;
- b) whether debris separates and whether it is flaming or glowing;
- c) whether flaming (or glowing) reaches any edge within 4 s of the end of the flame application time;
- d) whether flaming (or glowing) reaches any edge during application of the ignition source.

17 Observations during testing

Record for each product or specimen tested:

- a) flame source used;
- b) flame application time;
- c) face or edge exposure;
- d) whether a sustained ignition (greater than 4 s, see **3.1**) or transient ignition (less than 4 s, see **3.2**) occurs;
- e) whether debris separates and whether it is flaming or glowing;
- f) whether flaming (or glowing) reaches any edge within 4 s of the end of the flame application time;
- g) whether flaming (or glowing) reaches any edge during application of the ignition source.

18 Test report

The test report shall include the following:

- a) reference to this part of ISO 11925;
- b) identification and description of the product tested including its colour, thickness and density;
- c) full description of the test procedure, reference to a published method of test or reference to the test method detailed in this part of ISO 11925;
- d) for each specimen, the information recorded in accordance with clause **17**;
- e) the statement: "The test results relate only to the behaviour of the test specimens of the product under the particular conditions of test; they are not intended to be the sole criterion for assessing the potential fire hazard of the product in use".

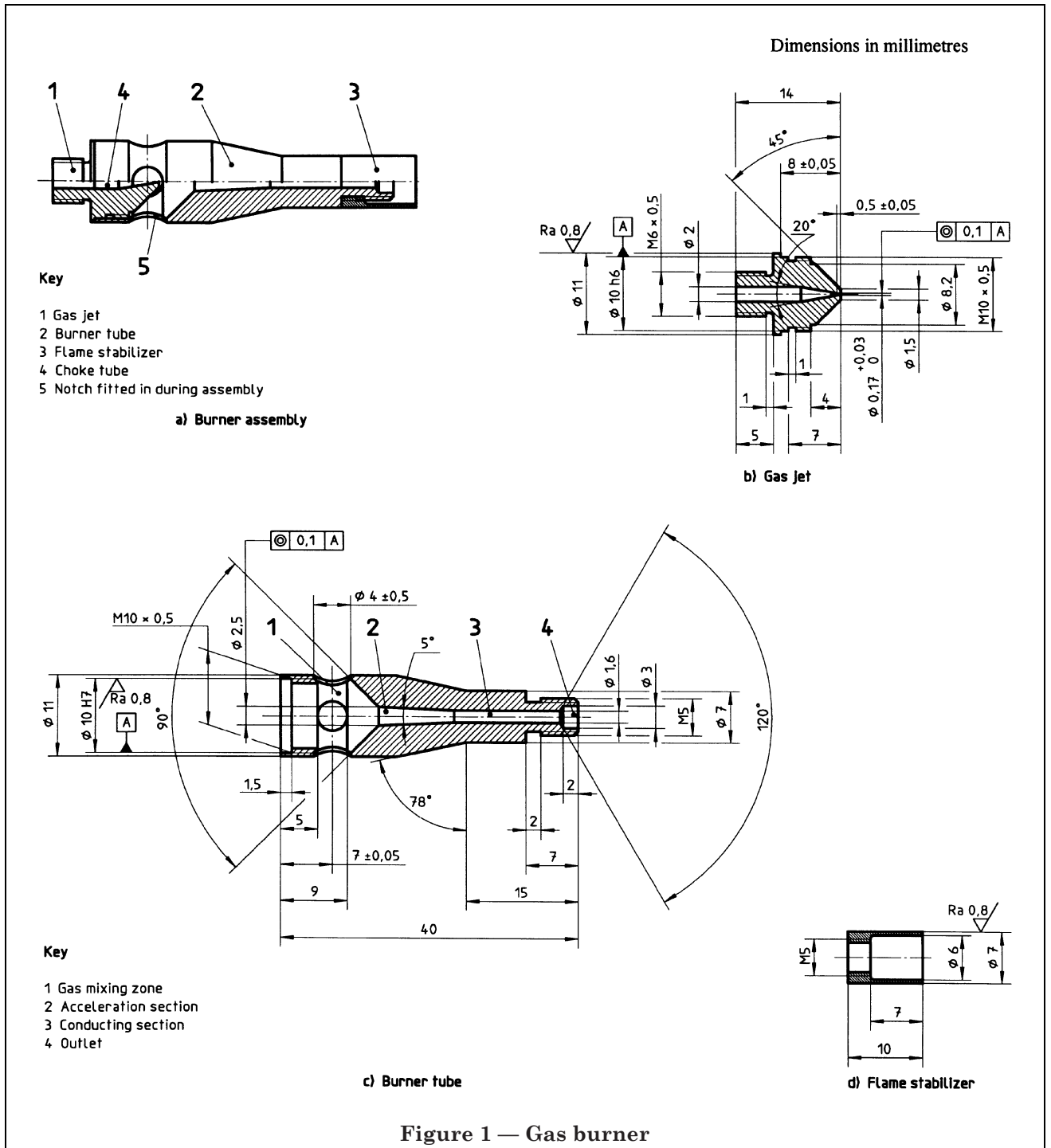

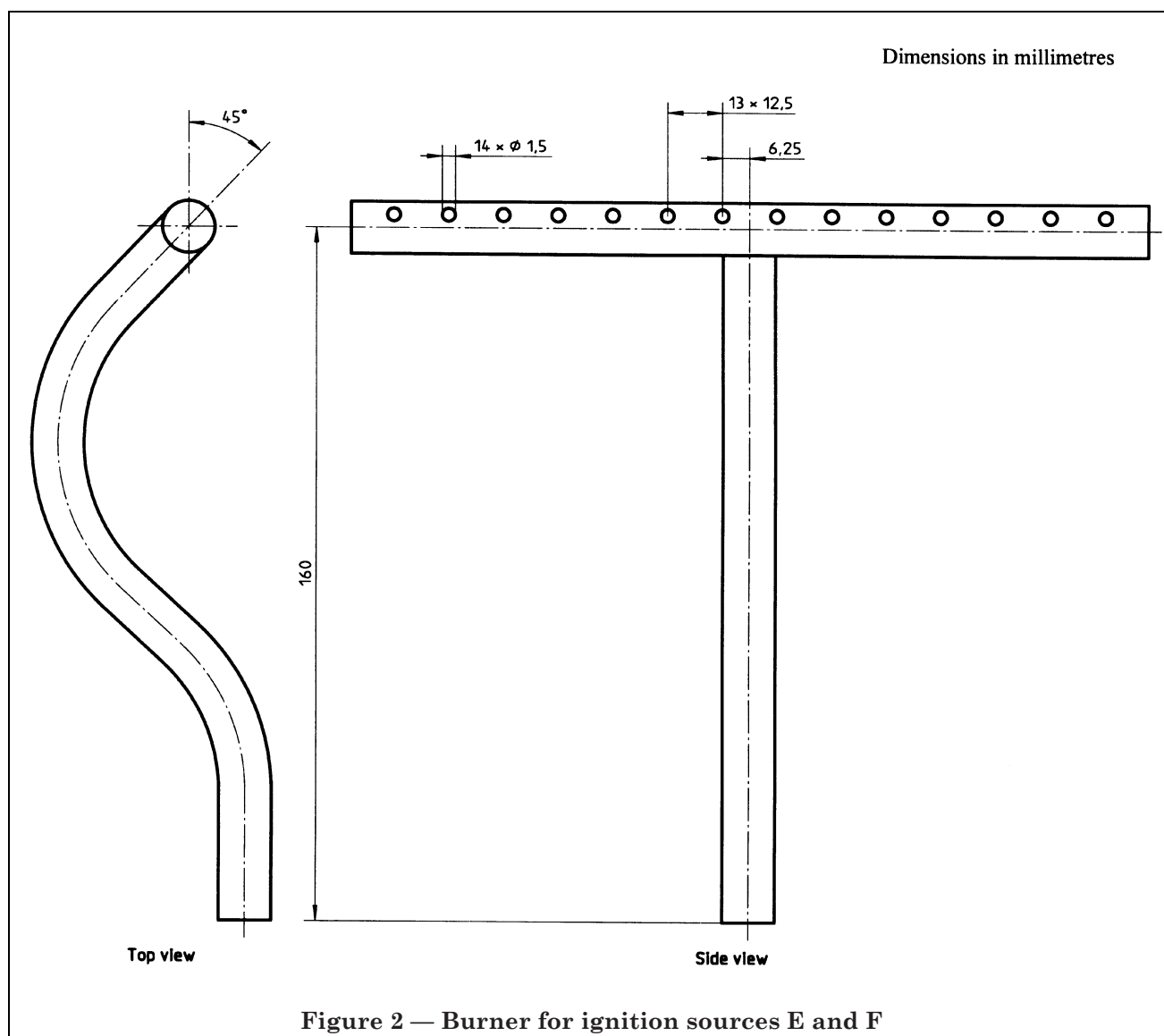

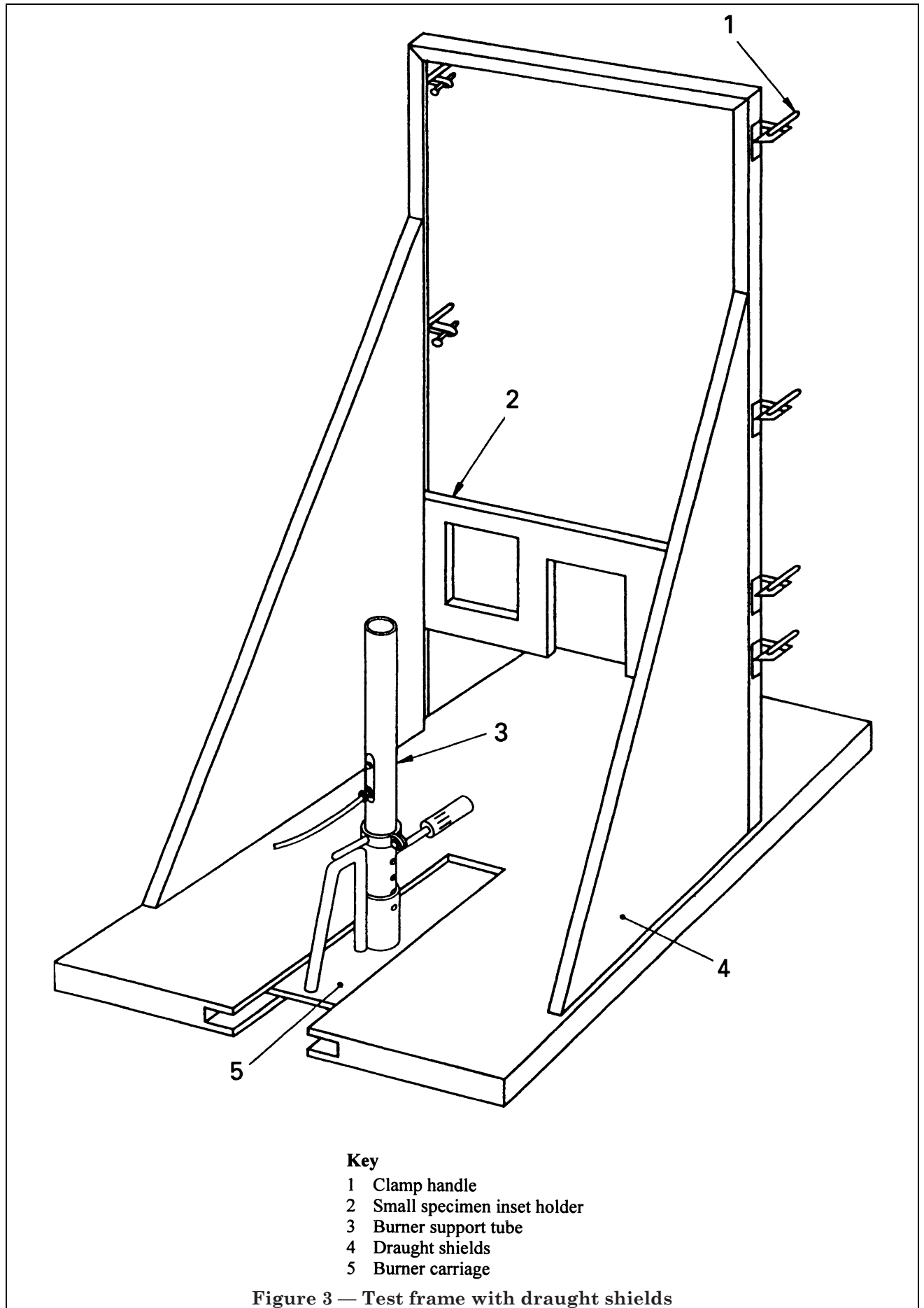

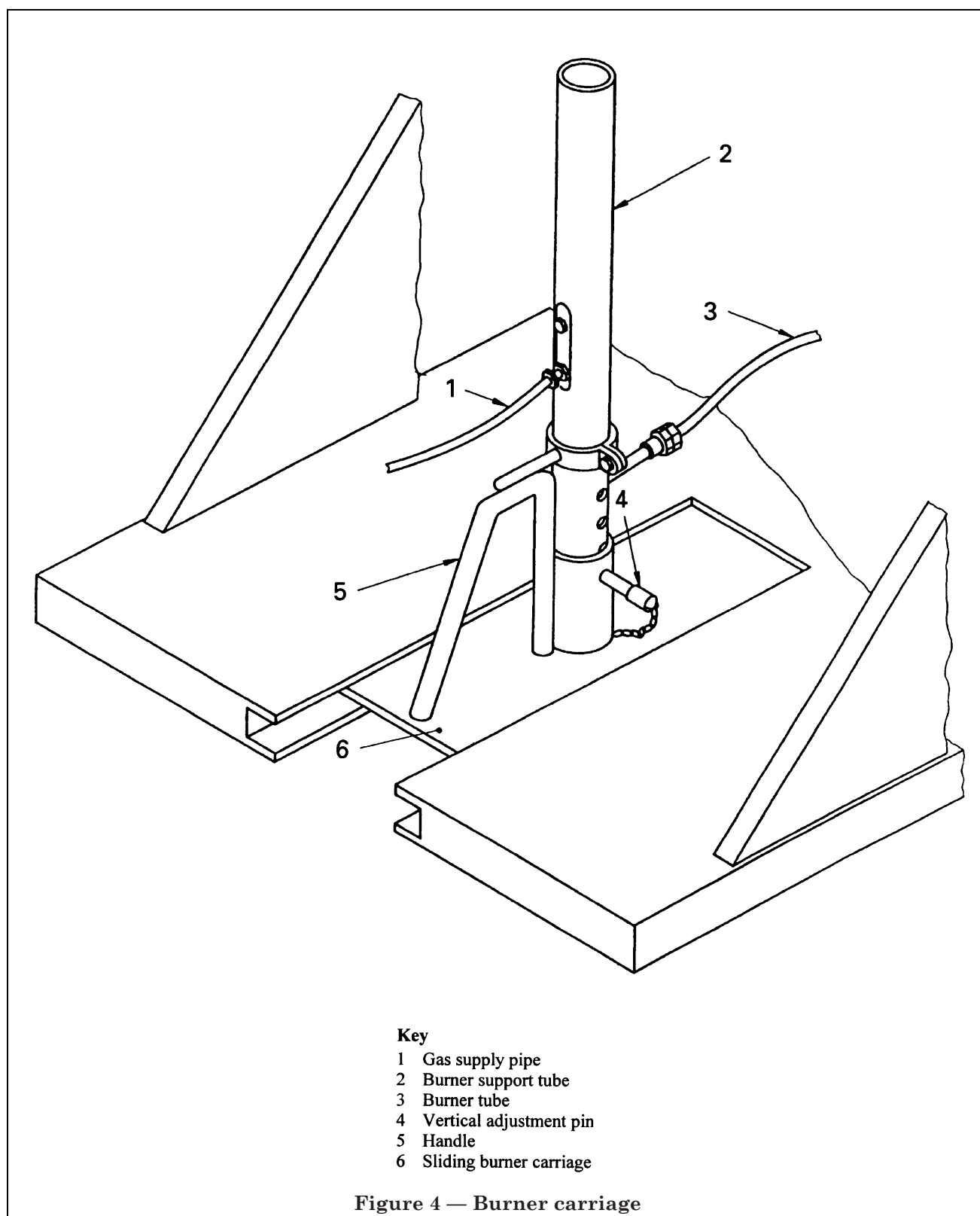

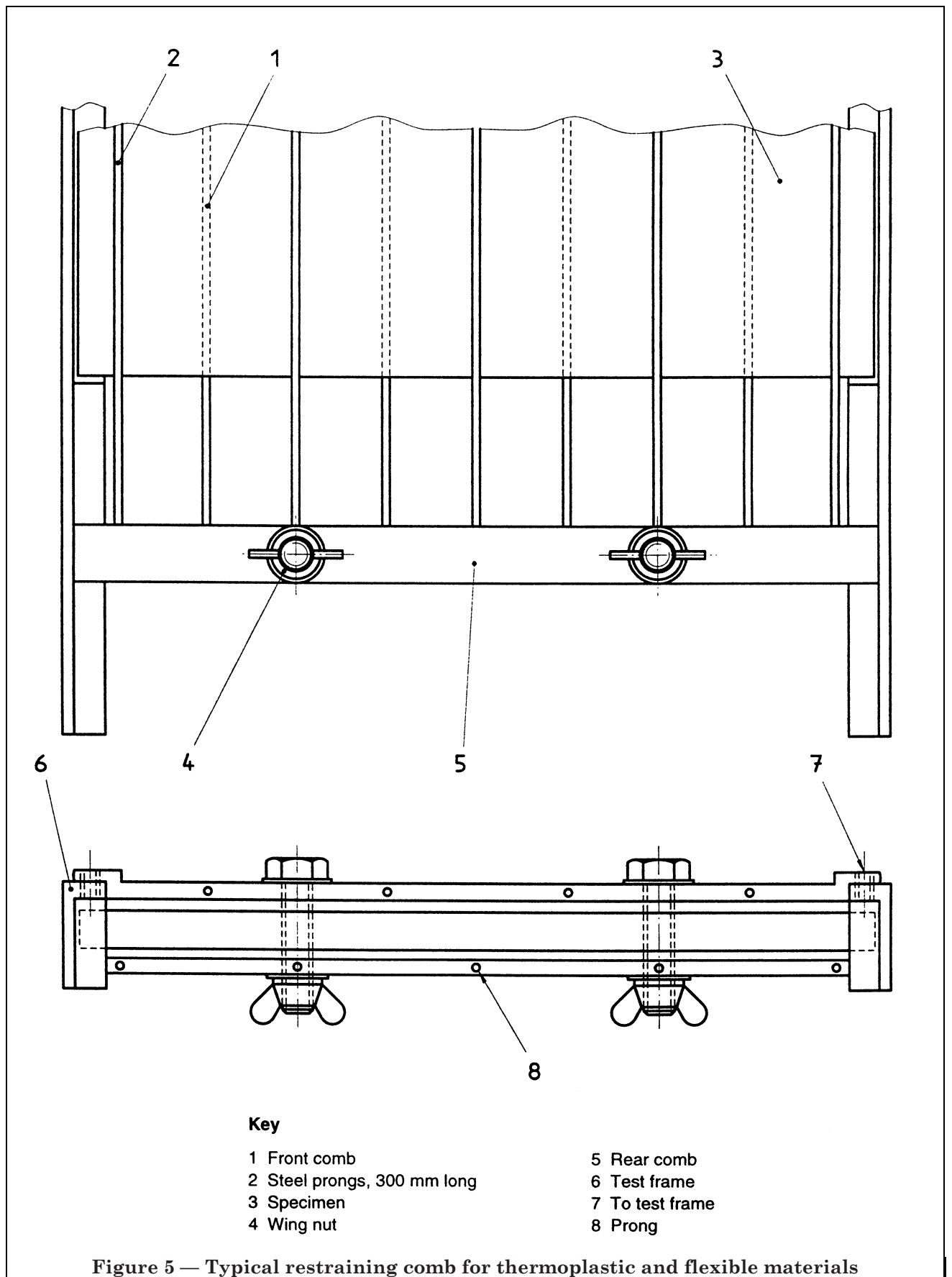

Dimensions in millimetres

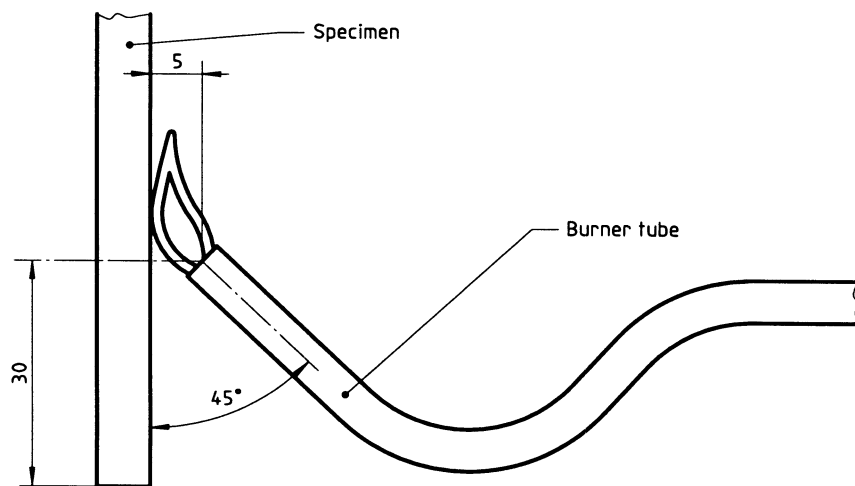

a) Sources A, B, C, D, E and F

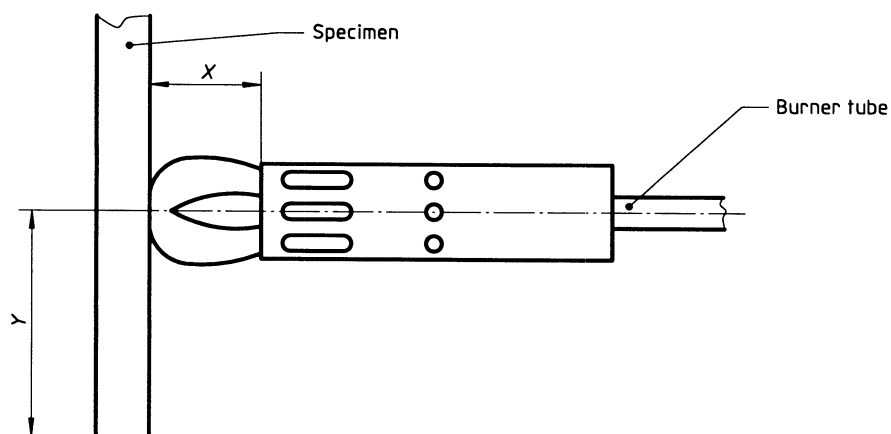

X is 90 mm for source G
and 70 mm for source H
Y is 150 mm for source G
and 300 mm for source H

b) Sources G and H

Figure 6 — Surface ignition

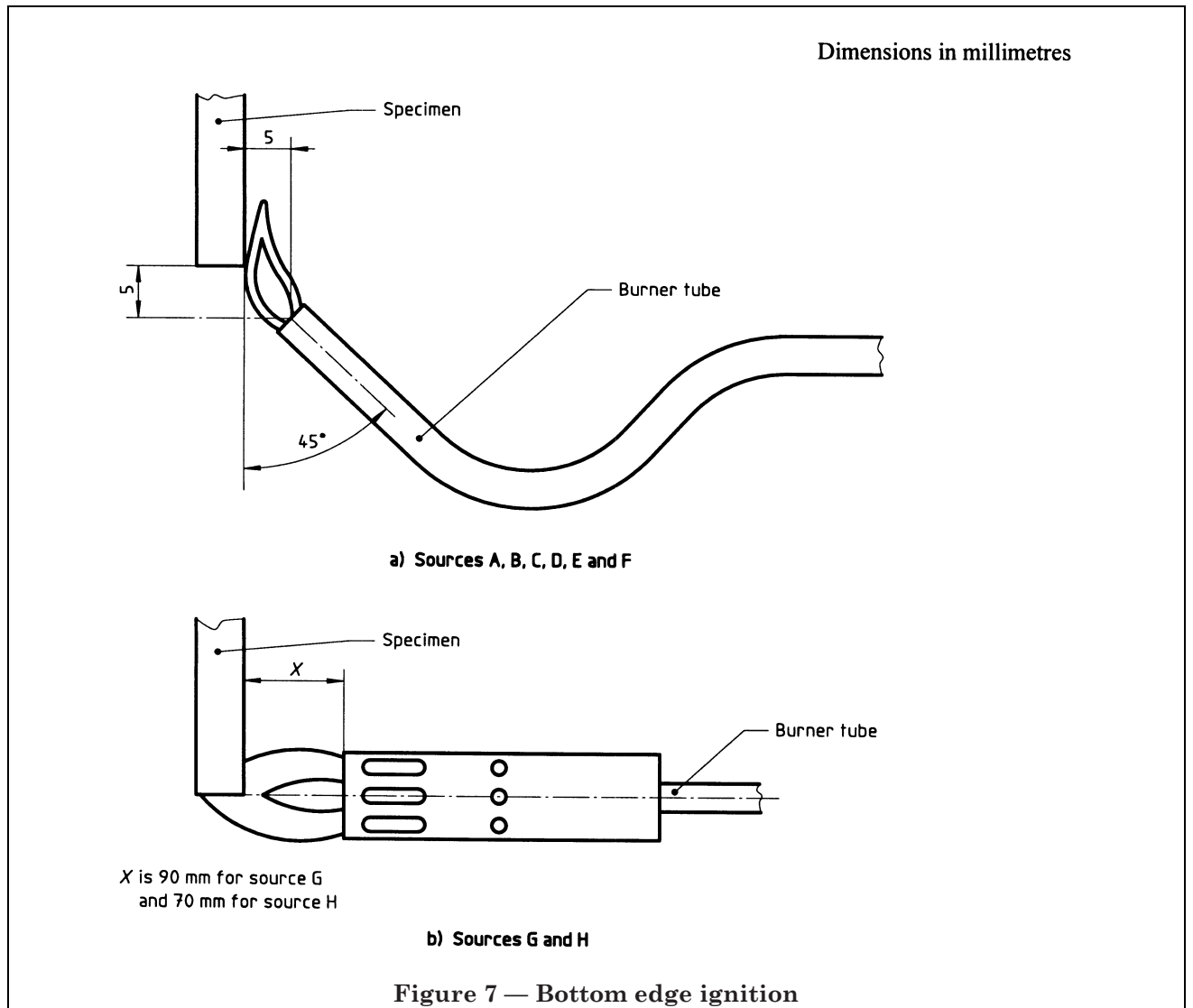

Annex A (informative)

Characteristics of ignition sources

| Ignition source | Description | Characteristics | | | | |
|-----------------|------------------------------------|-------------------------------|-----------------------------|--|------------------------------|-----------------------------|
| | | Calculated heat release kW | Measured heat release kW | Heat transfer (average) kW/m ² | Flame length (average) mm | Flame width (average) mm |
| A | Syringe burner micro flame | 0,04 | ^a | 36 | 12 | 5 |
| B | Kleinbrenner pre-mixed flame | 0,04 | ^a | 39 | 20 | 5 |
| C | Tube burner short flame | 0,063 5 | 0,08 | 40 | 35 | 11 |
| D | Tube burner long flame | 0,22 | 0,21 | 36 | 120 | 12 |
| E | Manifold burner | 2,8 | 3,1 | 45 | 240 | 170 |
| F | Manifold burner simulated chip pan | 13,9 | 14 to 20 | 47 | 780 | 170 |
| G | Plumbers' torch pre-mixed flame | 0,5 | 0,3 | 100 | 120 | 14 |
| H | Roofers' torch pre-mixed flame | 8,5 | 13 to 14 | 140 | 230 | 30 |

NOTE A to D and G and H: heat release measured under cone hood
E and F: heat release measured under ISO 9705 hood.

^a Below sensitivity level of measurement system.

Annex B (informative)

Use by specifiers

It is expected that with experience, specifiers will make use of this standard by requiring that a product does not ignite when tested by a specific ignition source for a specific flame application time.

Specifiers in reaching these decisions should consider the details of the end-use of the product.

For example, it may be decided that for a particular end use the product should not ignite when tested by source H for 60 s by face ignition.

In this case, it would be necessary to specify that the test should be carried out and none of the three specimens should ignite.

Because of the recognised variability of fire performance and fire tests, however, it may be appropriate to consider what action should be taken in the event of a single specimen igniting. This may be considered as an outlier and it may be acceptable to require that an additional three specimens be tested. If none of these additional specimens ignite, then the product could be accepted as complying with the requirement.

Annex C (informative)

Advice on testing end-use products

The various ignition sources described in this standard may also be used to determine the ignitability of end-use products which are not essentially flat. This may however require a modification of the normative procedure.

NOTE The modification to the procedure will normally only require a change in the specimen holder. In some instances, however, the burner carriage and/or the test frame may also be inappropriate and the ignition source(s) may need to be held and applied manually.

The product may be free standing or may be held in its end-use orientation in a retaining frame which may be as simple as a laboratory clamp stand or may require a more substantial, especially constructed framework. A full description of the method of retention should be given in the test report.

The product to be tested may be supplied in its entirety or as a specimen of minimum dimensions as described in Table 1, depending upon the ignition sources to be applied.

The flame sources used should be selected after some consideration of the perceived end-use hazard to the end-use product.

The flame source should be applied by manual operation for the application times specified in Table 1 for each relevant ignition source to a variety of positions on the test product or specimen depending on the perceived worst case (i.e. on an edge, corner, overhang, within a fold or cavity etc.). The positions to which the flame is applied should be accurately described within the test report.

For each ignition source, at least six flame applications to various positions should be conducted, three applications to each chosen position. A minimum of six specimens should therefore be provided.

For each of the specimens or products, the test results should be recorded as required in clause 18.

Annex D (informative)

Bibliography

- [1] ISO/TR 3814:1989, *Tests for measuring “reaction to fire” of building materials — Their development and application.*
- [2] ISO 5657:—, *Reaction to fire tests — Ignitability of building products using a radiant heat source¹⁾.*
- [3] ISO 9705:1993, *Fire tests — Full-scale room test for surface products — Single flame source test.*

¹⁾ To be published.

BSI — British Standards Institution

BSI is the independent national body responsible for preparing British Standards. It presents the UK view on standards in Europe and at the international level. It is incorporated by Royal Charter.

Revisions

British Standards are updated by amendment or revision. Users of British Standards should make sure that they possess the latest amendments or editions.

It is the constant aim of BSI to improve the quality of our products and services. We would be grateful if anyone finding an inaccuracy or ambiguity while using this British Standard would inform the Secretary of the technical committee responsible, the identity of which can be found on the inside front cover. Tel: 020 8996 9000. Fax: 020 8996 7400.

BSI offers members an individual updating service called PLUS which ensures that subscribers automatically receive the latest editions of standards.

Buying standards

Orders for all BSI, international and foreign standards publications should be addressed to Customer Services. Tel: 020 8996 9001. Fax: 020 8996 7001.

In response to orders for international standards, it is BSI policy to supply the BSI implementation of those that have been published as British Standards, unless otherwise requested.

Information on standards

BSI provides a wide range of information on national, European and international standards through its Library and its Technical Help to Exporters Service. Various BSI electronic information services are also available which give details on all its products and services. Contact the Information Centre. Tel: 020 8996 7111. Fax: 020 8996 7048.

Subscribing members of BSI are kept up to date with standards developments and receive substantial discounts on the purchase price of standards. For details of these and other benefits contact Membership Administration. Tel: 020 8996 7002. Fax: 020 8996 7001.

Copyright

Copyright subsists in all BSI publications. BSI also holds the copyright, in the UK, of the publications of the international standardization bodies. Except as permitted under the Copyright, Designs and Patents Act 1988 no extract may be reproduced, stored in a retrieval system or transmitted in any form or by any means – electronic, photocopying, recording or otherwise – without prior written permission from BSI.

This does not preclude the free use, in the course of implementing the standard, of necessary details such as symbols, and size, type or grade designations. If these details are to be used for any other purpose than implementation then the prior written permission of BSI must be obtained.

If permission is granted, the terms may include royalty payments or a licensing agreement. Details and advice can be obtained from the Copyright Manager. Tel: 020 8996 7070.