

BS ISO 11837:2011



BSI Standards Publication

# Machinery for forestry — Saw chain shot guarding systems — Test method and performance criteria

**bsi.**

...making excellence a habit.™

**National foreword**

This British Standard is the UK implementation of ISO 11837:2011.

The UK participation in its preparation was entrusted to Technical Committee AGE/29, Forestry machinery.

A list of organizations represented on this committee can be obtained on request to its secretary.

This publication does not purport to include all the necessary provisions of a contract. Users are responsible for its correct application.

© BSI 2011

ISBN 978 0 580 66309 3

ICS 65.060.80

**Compliance with a British Standard cannot confer immunity from legal obligations.**

This British Standard was published under the authority of the Standards Policy and Strategy Committee on 31 July 2011.

**Amendments issued since publication**

Date	Text affected
------	---------------

---

# INTERNATIONAL STANDARD

BS ISO 11837:2011

**ISO**  
**11837**

First edition  
2011-07-15

---

---

## **Machinery for forestry — Saw chain shot guarding systems — Test method and performance criteria**

*Matériel forestier — Système de protection contre l'éjection d'éléments  
de chaînes de scie — Méthode d'essai et critères de performance*



Reference number  
ISO 11837:2011(E)

© ISO 2011



**COPYRIGHT PROTECTED DOCUMENT**

© ISO 2011

All rights reserved. Unless otherwise specified, no part of this publication may be reproduced or utilized in any form or by any means, electronic or mechanical, including photocopying and microfilm, without permission in writing from either ISO at the address below or ISO's member body in the country of the requester.

ISO copyright office  
Case postale 56 • CH-1211 Geneva 20  
Tel. + 41 22 749 01 11  
Fax + 41 22 749 09 47  
E-mail [copyright@iso.org](mailto:copyright@iso.org)  
Web [www.iso.org](http://www.iso.org)

Published in Switzerland

# Contents

Page

Foreword .....	iv
Introduction .....	v
<b>1 Scope .....</b>	<b>1</b>
<b>2 Terms and definitions .....</b>	<b>1</b>
<b>3 Test equipment .....</b>	<b>2</b>
3.1 Test apparatus .....	2
3.2 Drive unit .....	2
3.3 Saw chain speed control .....	2
3.4 Drive shaft speed measurement .....	2
3.5 Saw chain tensioning system .....	2
3.6 Saw chain lubrication system .....	2
3.7 Saw chain stopping device .....	2
3.8 Protective cover .....	2
<b>4 Cutting attachment .....</b>	<b>2</b>
4.1 Guide bar .....	2
4.2 Drive sprocket .....	3
4.3 Saw chain .....	3
<b>5 Reference panels .....</b>	<b>3</b>
<b>6 Pre-calibration of test arrangement .....</b>	<b>3</b>
<b>7 Assembly of saw chain shot guarding system in test rig .....</b>	<b>4</b>
7.1 Position .....	4
7.2 Alternative positions .....	4
7.3 Obstacles .....	5
<b>8 Test procedure .....</b>	<b>5</b>
<b>9 Total number of test runs .....</b>	<b>6</b>
<b>10 Performance requirements .....</b>	<b>6</b>
<b>11 Test report .....</b>	<b>6</b>
<b>Annex A (normative) Saw chain stopping device .....</b>	<b>8</b>

## Foreword

ISO (the International Organization for Standardization) is a worldwide federation of national standards bodies (ISO member bodies). The work of preparing International Standards is normally carried out through ISO technical committees. Each member body interested in a subject for which a technical committee has been established has the right to be represented on that committee. International organizations, governmental and non-governmental, in liaison with ISO, also take part in the work. ISO collaborates closely with the International Electrotechnical Commission (IEC) on all matters of electrotechnical standardization.

International Standards are drafted in accordance with the rules given in the ISO/IEC Directives, Part 2.

The main task of technical committees is to prepare International Standards. Draft International Standards adopted by the technical committees are circulated to the member bodies for voting. Publication as an International Standard requires approval by at least 75 % of the member bodies casting a vote.

Attention is drawn to the possibility that some of the elements of this document may be the subject of patent rights. ISO shall not be held responsible for identifying any or all such patent rights.

ISO 11837 was prepared by Technical Committee ISO/TC 23, *Tractors and machinery for agriculture and forestry*, Subcommittee SC 15, *Machinery for forestry*.

## Introduction

On the basis of a risk analysis, the types of saw chain breakage can be determined and a saw chain shot guarding system selected that protects against these risks.

Harvester heads and grip saws need an effective saw chain shot guarding system. However, no such system can give 100 % safety protection against a saw chain shot. This International Standard specifies a method for evaluating the performance of a guarding system for the prevention of saw chain shot from behind the drive sprocket and upwards, relative to the direction of movement of the saw chain.

The test apparatus specified in this International Standard is designed to simulate the situation in which the saw chain becomes stuck in the wood at a cut and is broken. The end of the saw chain passes the drive sprocket in the guide bar plane. At different saw chain speeds and combinations of distance to the saw chain breakage, the break force, guide bar geometry and saw chain preload will throw the saw chain in a curve, producing a whiplash that could create a chain shot.

The test procedures presented in this International Standard can be used to evaluate a guarding system's ability to prevent the saw chain from producing whiplash and chain shot.





# Machinery for forestry — Saw chain shot guarding systems — Test method and performance criteria

**CAUTION** — The test method specified in this International Standard involves the use of processes which could lead to a hazardous situation. The test creates saw chain shots. Under no circumstances shall the test be performed without the protective cover for the test apparatus in place. The protective cover is only to be removed when rotating parts are standing still.

## 1 Scope

This International Standard specifies performance requirements and a corresponding test method for saw chain shot guarding systems on the harvester heads and grip saws of forestry machines.

It is applicable only to saw chain breakage on the cutting side of the guide bar.

**NOTE** Other test methods and test apparatus can be used if shown to give equivalent performance results.

## 2 Terms and definitions

For the purposes of this document, the following terms and definitions apply.

### 2.1

#### **saw chain shot**

object flying with high speed and consisting of one or more parts (drivelinks, sidelinks, cutters) of a broken saw chain

**NOTE 1** A saw chain consists of parts in the form of drivelinks, cutters and sidelinks held together by rivets.

**NOTE 2** The saw chain shot will have a weight of 1 g to 100 g, depending on the size of the saw chain and the broken saw chain parts.

**NOTE 3** During a test run, more than one saw chain shot can be created by the same saw chain whiplash, in different directions.

### 2.2

#### **maximum design saw chain speed**

*C*

highest saw chain speed under no load, for a given combination of saw chain, guide bar and drive sprocket

### 2.3

#### **cutting attachment**

combination of saw chain, guide bar and drive sprocket mounted on the harvester head or grip saw

### 2.4

#### **saw chain shot guarding system**

system that prevents the saw chain from whiplashing and/or creating a saw chain shot after passing the drive sprocket in the event of a saw chain breakage

### 2.5

#### **reference panel**

plane panel consisting of plastic film, kraft paper or similar material to indicate a saw chain shot

### **3 Test equipment**

#### **3.1 Test apparatus**

The saw chain shot guarding system, with all its component parts, shall be attached to the test rig as it would be on the respective harvester head or grip saw. Alternatively, the complete harvester head or grip saw shall be attached to the test rig.

#### **3.2 Drive unit**

The drive unit shall be maintained at constant speed to within 2 m/s during breakage, taking into account the increased force involved in the breakage of the saw chain.

NOTE One way to accommodate this is using an electric motor (15 kW and 50 r/s) with a belt transmission gearing up the speed four times and with a flywheel mass of 15 kg mounted on the drive shaft (360 mm in diameter and 19 mm in thickness).

#### **3.3 Saw chain speed control**

It shall be possible to adjust the saw chain speed within the range of 30 m/s to 60 m/s with a maximum tolerance of  $\pm 2$  m/s.

#### **3.4 Drive shaft speed measurement**

A drive shaft speed indicator shall be used to verify the saw chain speed with a maximum uncertainty of  $\pm 1,0$  % of the reading.

#### **3.5 Saw chain tensioning system**

The saw chain tensioning system shall tension the saw chain according to the manufacturer's recommendations.

#### **3.6 Saw chain lubrication system**

The saw chain lubrication system shall lubricate the saw chain with oil flow and oil quality according to the manufacturer's recommendations.

#### **3.7 Saw chain stopping device**

The saw chain stopping device shall be as specified in Annex A.

#### **3.8 Protective cover**

A protective cover shall fully enclose the test equipment and the harvester head or grip saw under test. The protective cover shall have a strength at least equivalent to 6 mm steel sheet.

### **4 Cutting attachment**

#### **4.1 Guide bar**

The longest available guide bar shall be chosen for the test runs. If a guide bar with a different shape is an option, it also shall be tested.

The mounting of the guide bar shall be on a unit with original mounting attachments, according to the manufacturer's specifications.

## 4.2 Drive sprocket

The test runs shall be performed within the manufacturer's operating specifications and with the drive sprocket available in the original cutting attachment that provides

- a) the highest saw chain speed, and
- b) the largest distance between the drive sprocket and the saw chain shot guarding system.

## 4.3 Saw chain

A saw chain that is recommended in the harvester-head or grip-saw manufacturer's instruction handbook for use together with the guide bar and drive sprocket shall be chosen. One of the following reference saw chain dimensions shall be preferred:

- saw chain with 0,404 inch pitch, thickness 1,6 mm;
- saw chain with 0,404 inch pitch, thickness 2,0 mm;
- saw chain with 3/4 inch pitch, thickness 3,1 mm.

The number of drive links is determined in relation to the guide bar length.

## 5 Reference panels

There shall be two reference panels (see items 1a and 1b in Figure 1) with a width of  $400 \text{ mm} \pm 20 \text{ mm}$  and a length of  $1\ 000 \text{ mm} \pm 20 \text{ mm}$ , consisting of plastic film, kraft paper or similar material. The location and orientation of the two reference panels shall be as described in Figure 1.

## 6 Pre-calibration of test arrangement

The pre-calibration is performed in order to secure the statistical confidence of the test results.

Ten test runs without the saw chain shot guarding system mounted shall be performed to evaluate the functioning of the test arrangement. Perform the test procedure specified in Clause 8, but without assembling the saw chain guarding system. Run five test runs at 0,8 times the maximum design saw chain speed,  $C$ , and five test runs at  $1,2C$ . At least four of the five test runs at each speed shall result in a saw chain shot through one of the reference panels.

If a complete harvester head or grip saw is tested, some parts of the saw chain shot guarding system and obstacles (see 7.3) will have to be removed prior to the pre-calibration tests, to ensure that saw chain shots are created.

If the criterion of at least four saw chain shots out of five test runs is not met, the test arrangement shall be modified and the pre-calibration repeated until this criterion is met.

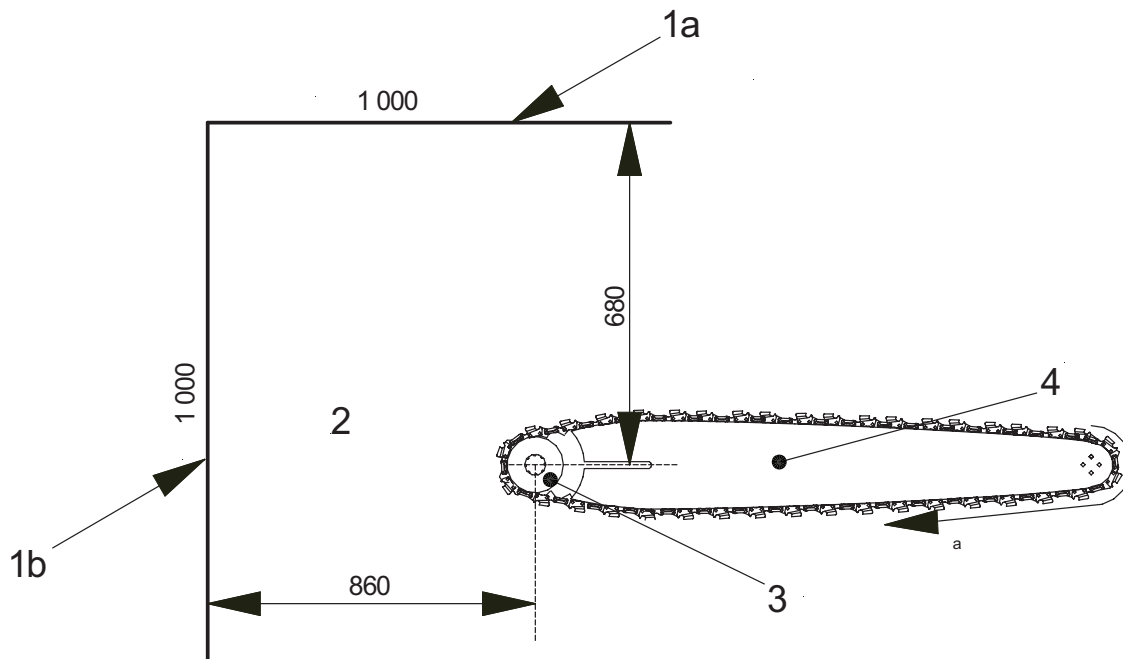

**Key**

- 1a reference panel parallel to the guide bar centre line
- 1b reference panel perpendicular to the guide bar centre line
- 2 saw chain shot area
- 3 drive sprocket
- 4 guide bar
- a Saw chain rotation direction.

**Figure 1 — Guide bar and location of reference planes**

## 7 Assembly of saw chain shot guarding system in test rig

### 7.1 Position

The saw chain shot guarding system shall be positioned at the same distance, in both the horizontal and vertical directions, from the drive sprocket as it was originally on the harvester head or grip saw.

### 7.2 Alternative positions

If the position of the saw chain shot guarding system changes relative to the guide bar during cutting, the system shall be tested in the following three different positions:

- Position 1 — guide bar in “home” position;
- Position 2 — guide bar at half cutting depth;
- Position 3 — guide bar at maximum cutting depth.

### 7.3 Obstacles

Any part or parts on the harvester head or grip saw which can be considered to influence the behaviour of a broken saw chain shall be included in the test.

EXAMPLE Screws, nuts, welding, saw casing and reinforcements.

## 8 Test procedure

The test shall be performed as follows.

- a) Assemble the saw chain shot guarding system and the cutting attachment (guide bar, saw chain and drive sprocket) in the test rig. Use only new saw chains.

Alternatively, a complete harvester head or grip saw may be attached to the test rig.

- b) Connect the drive sprocket to the drive system and activate the saw chain lubrication system.
- c) Position the saw chain stopping device (see Annex A). The position shall depend on the guide bar length,  $X_S$ , measured from the centre of the drive sprocket to the guide bar tip. See Figure 2. Distance  $X_1$  shall be  $0,5X_S$  and distance  $X_2$  shall be  $0,8X_S$ .

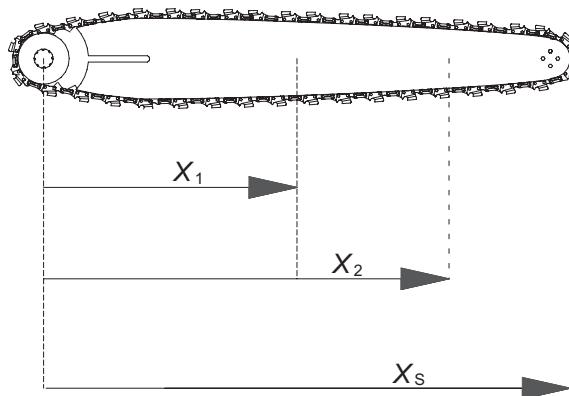

Figure 2 — Saw chain stopping device positions

- d) Preload the saw chain stopping device and block it in the start position as close as possible to the saw chain while allowing the saw chain to move freely. See Figure A.1.
- e) Unblock the saw chain stopping device and put the protective cover in position before performing any test runs.
- f) Adjust the saw chain tension and, with the protective cover in place, allow the cutting attachment to run in and warm up.
- g) Start the test run by running the saw chain.
- h) Adjust and calibrate the saw chain speed to the chosen test speed, maintaining that speed constant to within  $\pm 2$  m/s.
- i) Release the saw chain stopping device.
- j) Turn off the power source to the drive system and allow all rotating parts to come to a complete stop.
- k) Open the protective cover.
- l) Evaluate all reference panels. If a reference panel has been penetrated by a saw chain, report this.
- m) Photograph each test sample of broken saw chain, including all loose parts.
- n) Continue with the next test run in accordance with Clause 9.

## 9 Total number of test runs

Each test run shall consist of three tests with the same configuration of the test rig. The total number of test runs will also depend on the number of different guide bars (see 4.1), sprockets (see 4.2) and possible saw chain shot guarding system positions (see 7.2), as well as at least two chosen saw chain stopping device positions [see Clause 8, c)] and two different saw chain speeds. The two different saw chain speeds shall be

- 1,2 times the maximum design saw chain speed, *C*, and
- 0,8 times the maximum design saw chain speed, *C*.

Table 1 presents the required test run sequence with two types of guide bar and a possible position of the saw chain shot guarding system.

For the evaluation of the wear resistance on the saw chain shot guarding system, at least 24 test runs shall be performed. If only one guide bar is tested, then repeat test run Nos. 1 to 12 at different saw chain speeds and saw chain stopping device positions.

## 10 Performance requirements

The saw chain shot guarding system shall be considered to have failed if a saw chain shot passes through the reference panel in any of the individual test runs.

The wear from the saw chain on the saw chain shot guarding system shall be maximum 50 % of the original material thickness or 2 mm, whichever is less, after 24 test runs.

## 11 Test report

The test report shall contain at least the test results recorded in Table 1 as well as the following information:

- a) description of test facility or test location, name of the tester, date of the test;
- b) a reference to this International Standard (i.e. ISO 11837);
- c) identification of the saw chain shot guarding system (manufacturer, photographs, drawing number or part number);
- d) the saw chain shot guarding system design and material specification (photographs or drawings);
- e) assembly of the saw chain shot guarding system in the test rig, including any hindrance from the structure near the sprocket area (photographs or drawings);
- f) identification of alternative positions of the saw chain shot guarding system (if applicable);
- g) cutting attachment (saw chain, guide bar and sprocket);
- h) saw chain tensioning;
- i) type of saw chain lubrication;
- j) description of the test run sequence (saw chain speed, position of the saw chain shot guarding system, position of the saw chain stopping device, guide bar and sprocket);
- k) number of saw chain shots passing through the reference panels (see Clause 10);
- l) wear on the saw chain shot guarding system after 24 test runs (see Clause 10);
- m) photos or videos of each test run sample of broken saw chain, including all loose parts;

- n) a concluding statement on the test results, including information on the saw chain shot guarding system to which the test results are applicable;
- o) any modification of the test arrangement and test procedure that might have been necessary, including justification for such modification.

**Table 1 — Required test run sequence**

Test run No.	Saw chain speed m/s	Alternative position of saw chain shot guarding system	Distance for positioning saw chain stopping device	Guide bar No.	Sprocket No.	Result (position of saw chain shot through reference panel)	Saw chain part No. (photo)
1	1,2C	A	X <sub>1</sub>	1	1		
2	1,2C	A	X <sub>1</sub>	1	1		
3	1,2C	A	X <sub>1</sub>	1	1		
4	0,8C	A	X <sub>1</sub>	1	1		
5	0,8C	A	X <sub>1</sub>	1	1		
6	0,8C	A	X <sub>1</sub>	1	1		
7	1,2C	A	X <sub>2</sub>	1	1		
8	1,2C	A	X <sub>2</sub>	1	1		
9	1,2C	A	X <sub>2</sub>	1	1		
10	0,8C	A	X <sub>2</sub>	1	1		
11	0,8C	A	X <sub>2</sub>	1	1		
12	0,8C	A	X <sub>2</sub>	1	1		
13	1,2C	A	X <sub>1</sub>	2	1		
14	1,2C	A	X <sub>1</sub>	2	1		
15	1,2C	A	X <sub>1</sub>	2	1		
16	0,8C	A	X <sub>1</sub>	2	1		
17	0,8C	A	X <sub>1</sub>	2	1		
18	0,8C	A	X <sub>1</sub>	2	1		
19	1,2C	A	X <sub>2</sub>	2	1		
20	1,2C	A	X <sub>2</sub>	2	1		
21	1,2C	A	X <sub>2</sub>	2	1		
22	0,8C	A	X <sub>2</sub>	2	1		
23	0,8C	A	X <sub>2</sub>	2	1		
24	0,8C	A	X <sub>2</sub>	2	1		
n	...	...	...	...	...		
<p>C maximum design saw chain speed</p> <p>A Position 1, 2 or 3 in accordance with 7.2</p> <p>X<sub>1</sub>, X<sub>2</sub> see 8 c) and Figure 2</p>							

## Annex A (normative)

### Saw chain stopping device

The function of the saw chain stopping device is to grab and block the moving saw chain within half the pitch, without clamping the saw chain up to the guide bar.

The saw chain stopping device consists of the following:

- a) a mechanism for positioning the stopping device in relation to the guide bar at specified locations;
- b) a stroke limiter (see Figure A.1) for adjusting the height of the saw chain stopping device tip so that it will, in its released position (see Figure A.2) grab and block the moving saw chain without clamping the saw chain up to the guide bar (see Figure A.3);
- c) a mechanism to hold the saw chain stopping device tip preloaded and blocked in a start position (see Figure A.1);
- d) a mechanism to release the saw chain stopping device tip from its start position, preferably by remote control (see Figure A.2).

The shape of the tip of the stopping device shall be modified to fit the shape of the saw chain cutting link (see Figure A.3). The height of the tip shall be 1,5 times the height of the saw tooth. The tip design must be strong enough for the forces involved.

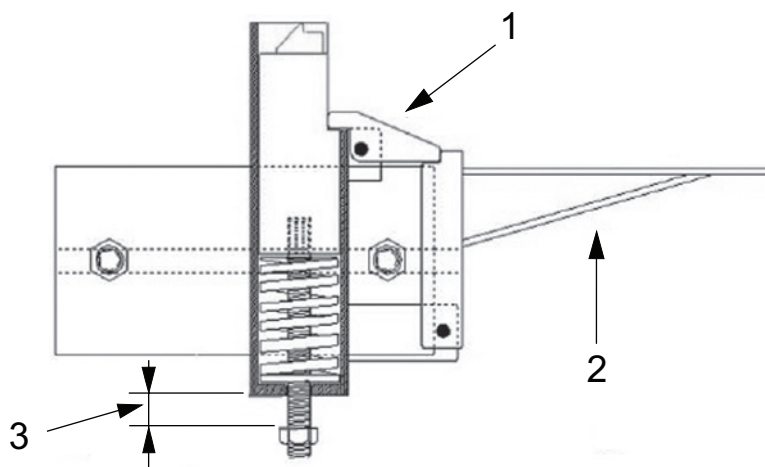

#### Key

- 1 blocking mechanism in blocked position
- 2 release mechanism
- 3 stroke limiter

Figure A.1 — Preloaded and blocked saw chain stopping device



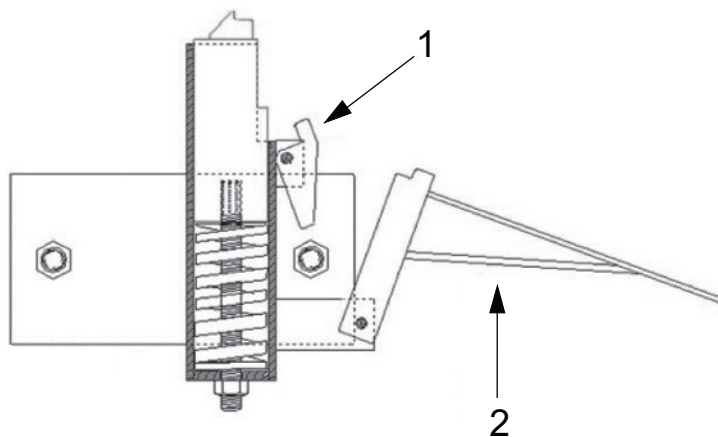

**Key**

- 1 blocking mechanism in released position
- 2 release mechanism

**Figure A.2 — Released saw chain stopping device**

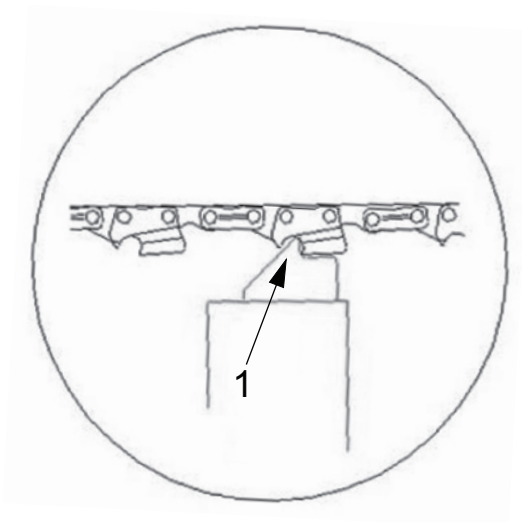

**Key**

- 1 tip of saw chain stopping device

**Figure A.3 — Saw chain stopping device blocking the saw chain**

---

---

**ICS 65.060.80**

Price based on 9 pages



# British Standards Institution (BSI)

BSI is the national body responsible for preparing British Standards and other standards-related publications, information and services.

BSI is incorporated by Royal Charter. British Standards and other standardization products are published by BSI Standards Limited.

## About us

We bring together business, industry, government, consumers, innovators and others to shape their combined experience and expertise into standards-based solutions.

The knowledge embodied in our standards has been carefully assembled in a dependable format and refined through our open consultation process. Organizations of all sizes and across all sectors choose standards to help them achieve their goals.

## Information on standards

We can provide you with the knowledge that your organization needs to succeed. Find out more about British Standards by visiting our website at [bsigroup.com/standards](http://bsigroup.com/standards) or contacting our Customer Services team or Knowledge Centre.

## Buying standards

You can buy and download PDF versions of BSI publications, including British and adopted European and international standards, through our website at [bsigroup.com/shop](http://bsigroup.com/shop), where hard copies can also be purchased.

If you need international and foreign standards from other Standards Development Organizations, hard copies can be ordered from our Customer Services team.

## Subscriptions

Our range of subscription services are designed to make using standards easier for you. For further information on our subscription products go to [bsigroup.com/subscriptions](http://bsigroup.com/subscriptions).

With **British Standards Online (BSOL)** you'll have instant access to over 55,000 British and adopted European and international standards from your desktop. It's available 24/7 and is refreshed daily so you'll always be up to date.

You can keep in touch with standards developments and receive substantial discounts on the purchase price of standards, both in single copy and subscription format, by becoming a **BSI Subscribing Member**.

**PLUS** is an updating service exclusive to BSI Subscribing Members. You will automatically receive the latest hard copy of your standards when they're revised or replaced.

To find out more about becoming a BSI Subscribing Member and the benefits of membership, please visit [bsigroup.com/shop](http://bsigroup.com/shop).

With a **Multi-User Network Licence (MUNL)** you are able to host standards publications on your intranet. Licences can cover as few or as many users as you wish. With updates supplied as soon as they're available, you can be sure your documentation is current. For further information, email [bsmusales@bsigroup.com](mailto:bsmusales@bsigroup.com).

## BSI Group Headquarters

389 Chiswick High Road London W4 4AL UK

## Revisions

Our British Standards and other publications are updated by amendment or revision.

We continually improve the quality of our products and services to benefit your business. If you find an inaccuracy or ambiguity within a British Standard or other BSI publication please inform the Knowledge Centre.

## Copyright

All the data, software and documentation set out in all British Standards and other BSI publications are the property of and copyrighted by BSI, or some person or entity that owns copyright in the information used (such as the international standardization bodies) and has formally licensed such information to BSI for commercial publication and use. Except as permitted under the Copyright, Designs and Patents Act 1988 no extract may be reproduced, stored in a retrieval system or transmitted in any form or by any means – electronic, photocopying, recording or otherwise – without prior written permission from BSI. Details and advice can be obtained from the Copyright & Licensing Department.

## Useful Contacts:

### Customer Services

**Tel:** +44 845 086 9001

**Email (orders):** [orders@bsigroup.com](mailto:orders@bsigroup.com)

**Email (enquiries):** [cservices@bsigroup.com](mailto:cservices@bsigroup.com)

### Subscriptions

**Tel:** +44 845 086 9001

**Email:** [subscriptions@bsigroup.com](mailto:subscriptions@bsigroup.com)

### Knowledge Centre

**Tel:** +44 20 8996 7004

**Email:** [knowledgecentre@bsigroup.com](mailto:knowledgecentre@bsigroup.com)

### Copyright & Licensing

**Tel:** +44 20 8996 7070

**Email:** [copyright@bsigroup.com](mailto:copyright@bsigroup.com)



...making excellence a habit.™