

# Tractors and machinery for agriculture and forestry — Serial control and communications data network —

**Part 1: General standard for mobile  
data communication**

ICS 35.240.99; 65.060.01

## National foreword

This British Standard is the UK implementation of ISO 11783-1:2007.

The UK participation in its preparation was entrusted by Technical Committee AGE/6, Agricultural tractors and forestry machinery, to Subcommittee AGE/6/1, Agricultural electronics.

A list of organizations represented on this committee can be obtained on request to its secretary.

This publication does not purport to include all the necessary provisions of a contract. Users are responsible for its correct application.

**Compliance with a British Standard cannot confer immunity from legal obligations.**

This British Standard was published under the authority of the Standards Policy and Strategy Committee on 31 July 2007

© BSI 2007

ISBN 978 0 580 55628 9

### Amendments issued since publication

Amd. No.	Date	Comments

INTERNATIONAL  
STANDARD

**ISO**  
**11783-1**

First edition  
2007-06-15

---

---

**Tractors and machinery for agriculture  
and forestry — Serial control and  
communications data network —**

Part 1:  
**General standard for mobile data  
communication**

*Tracteurs et matériels agricoles et forestiers — Réseaux de commande  
et de communication de données en série —*

*Partie 1: Système normalisé général pour les communications de  
données avec les équipements mobiles*



Reference number  
ISO 11783-1:2007(E)



# Contents

Page

Foreword.....	iv
Introduction .....	v
<b>1 Scope .....</b>	<b>1</b>
<b>2 Normative references .....</b>	<b>1</b>
<b>3 Terms and definitions.....</b>	<b>1</b>
<b>4 Abbreviated terms .....</b>	<b>9</b>
<b>5 Application of OSI model to ISO 11783 .....</b>	<b>10</b>
<b>6 ISO 11783 network requirements .....</b>	<b>11</b>
<b>6.1 General.....</b>	<b>11</b>
<b>6.2 Physical layer .....</b>	<b>11</b>
<b>6.3 Data link layer.....</b>	<b>11</b>
<b>6.4 Network layer .....</b>	<b>13</b>
<b>6.5 Network management.....</b>	<b>13</b>
<b>6.6 Network segments .....</b>	<b>13</b>
<b>6.7 Virtual terminal.....</b>	<b>15</b>
<b>6.8 Tractor ECU .....</b>	<b>15</b>
<b>6.9 Task controllers .....</b>	<b>15</b>
<b>6.10 Farm management computer interface .....</b>	<b>15</b>
<b>6.11 Diagnostics.....</b>	<b>16</b>
<b>6.12 File server .....</b>	<b>16</b>
<b>6.13 Process data.....</b>	<b>16</b>
<b>6.14 Working sets .....</b>	<b>16</b>
<b>6.15 Safe mode operation .....</b>	<b>18</b>
<b>6.16 Addition of parameters and messages.....</b>	<b>18</b>
<b>Annex A (normative) Parameter group assignments .....</b>	<b>19</b>
<b>Annex B (normative) ISO 11783 Industry groups .....</b>	<b>53</b>
<b>Annex C (normative) ISO 11783 Industry group 0 preferred addresses .....</b>	<b>54</b>
<b>Annex D (normative) ISO 11783 Industry group 2 initial addresses.....</b>	<b>59</b>
<b>Annex E (normative) ISO 11783 NAMEs .....</b>	<b>60</b>
<b>Annex F (normative) ISO 11783 All industry NAMEs.....</b>	<b>75</b>
<b>Annex G (normative) ISO 11783 manufacturer codes .....</b>	<b>81</b>
<b>Annex H (informative) ISO 11783 Request forms.....</b>	<b>88</b>
<b>Bibliography .....</b>	<b>94</b>

## Foreword

ISO (the International Organization for Standardization) is a worldwide federation of national standards bodies (ISO member bodies). The work of preparing International Standards is normally carried out through ISO technical committees. Each member body interested in a subject for which a technical committee has been established has the right to be represented on that committee. International organizations, governmental and non-governmental, in liaison with ISO, also take part in the work. ISO collaborates closely with the International Electrotechnical Commission (IEC) on all matters of electrotechnical standardization.

International Standards are drafted in accordance with the rules given in the ISO/IEC Directives, Part 2.

The main task of technical committees is to prepare International Standards. Draft International Standards adopted by the technical committees are circulated to the member bodies for voting. Publication as an International Standard requires approval by at least 75 % of the member bodies casting a vote.

ISO 11783-1 was prepared by Technical Committee ISO/TC 23, *Tractors and machinery for agriculture and forestry*, Subcommittee SC 19, *Agricultural electronics*.

ISO 11783 consists of the following parts, under the general title *Tractors and machinery for agriculture and forestry — Serial control and communications data network*:

- *Part 1: General standard for mobile data communication*
- *Part 2: Physical layer*
- *Part 3: Data link layer*
- *Part 4: Network layer*
- *Part 5: Network management*
- *Part 6: Virtual terminal*
- *Part 7: Implement messages application layer*
- *Part 8: Power train messages*
- *Part 9: Tractor ECU*
- *Part 10: Task controller and management information system data interchange*
- *Part 11: Mobile data element dictionary*
- *Part 12: Diagnostics services*
- *Part 13: File server*

Automated functions is to form the subject of a future part 14.

## Introduction

ISO 11783 specifies a communications system for agricultural equipment based on the CAN 2.0 B [1] protocol. SAE J 1939 documents<sup>1)</sup>, on which parts of ISO 11783 are based, were developed jointly for use in truck and bus applications and for construction and agriculture applications. Joint documents were completed to allow electronic units that meet the truck and bus SAE J 1939 specifications to be used by agricultural and forestry equipment with minimal changes. General information on ISO 11783 is to be found in this part of ISO 11783.

The purpose of ISO 11783 is to provide an open, interconnected system for on-board electronic systems. It is intended to enable electronic control units (ECUs) to communicate with each other, providing a standardized system.

The International Organization for Standardization (ISO) draws attention to the fact that it is claimed that compliance with this part of ISO 11783 may involve the use of a patent concerning the controller area network (CAN) protocol referred to throughout the document.

ISO takes no position concerning the evidence, validity and scope of this patent.

The holder of this patent has assured ISO that he is willing to negotiate licences under reasonable and non-discriminatory terms and conditions with applicants throughout the world. In this respect, the statement of the holder of this patent right is registered with ISO. Information may be obtained from:

Robert Bosch GmbH  
Wernerstrasse 51  
Postfach 30 02 20  
D-70442 Stuttgart-Feuerbach  
Germany

Attention is drawn to the possibility that some of the elements of this part of ISO 11783 may be the subject of patent rights other than those identified above. ISO shall not be held responsible for identifying any or all such patent rights.

---

1) Society of Automotive Engineers, Warrendale, PA, USA.





# Tractors and machinery for agriculture and forestry — Serial control and communications data network —

## Part 1: General standard for mobile data communication

### 1 Scope

ISO 11783 as a whole specifies a serial data network for control and communications on forestry or agricultural tractors and mounted, semi-mounted, towed or self-propelled implements. Its purpose is to standardize the method and format of transfer of data between sensors, actuators, control elements, and information-storage and -display units, whether mounted on, or part of, the tractor or implement. It is intended to provide open system interconnect (OSI) for electronic systems used by agricultural and forestry equipment. This part of ISO 11783 gives a general overview of ISO 11783. Its annexes contain the identifiers for messages, addresses, control functions, implements and manufacturers, required for the implementation of a compliant network.

### 2 Normative references

The following referenced documents are indispensable for the application of this document. For dated references, only the edition cited applies. For undated references, the latest edition of the referenced document (including any amendments) applies.

ISO 11783 (all parts), *Tractors and machinery for agriculture and forestry — Serial control and communications data network*

ISO 11898-1, *Road vehicles — Controller area network (CAN) — Part 1: Data link layer and physical signalling*

ISO 11898-2, *Road vehicles — Controller area network (CAN) — Part 2: High-speed medium access unit*

### 3 Terms and definitions

For the purposes of this document, the following terms and definitions apply.

#### 3.1

##### **active mask**

collection of display elements selected by a working set for display on a virtual terminal

NOTE An active mask may or need not be visible.

#### 3.2

##### **address**

eight-bit field used to define the source or destination of a message

#### 3.3

##### **alarm mask**

object that defines alarm information for display on a virtual terminal

**3.4  
auxiliary input unit**

electronic control unit providing auxiliary controls for common use

NOTE These may be physically located on the virtual terminal.

**3.5  
bridge**

electronic control unit interconnecting two ISO 11783 network segments that stores and forwards messages between the two or more network segments

NOTE 1 This permits changes of media, the electrical interface, and data rate between segments, but the data link protocol and address space are the same on both connections of a bridge.

NOTE 2 A bridge can selectively filter messages going across it so that the network load is minimized on each segment.

**3.6  
coding data**

data that changes infrequently, such as machine or chemical data, or that does not vary from task to task

**3.7  
command configurable address**

source address of a control function that can be altered using the command address message during normal operations

**3.8  
control function**

function that performs operations to complete a specific function on or within devices

NOTE A control function has one unique address on the network.

**3.9  
data dictionary**

listing of data variables and their identifiers

NOTE The data dictionary is defined in ISO 11783-11.

**3.10  
data dictionary entity**

process data variable data dictionary identifier, definition, value range, value resolution and units specifications

**3.11  
data dictionary identifier**

16-bit number that uniquely identifies a data dictionary entity

NOTE The data dictionary identifier is used in the process data message to identify the data dictionary entity for which a value or command is communicated.

**3.12  
data page**

bit in the identifier portion of the CAN arbitration field used to select one of two pages of parameter group numbers

**3.13  
data transfer file**

generic term for files in the extensible markup language format, which are used for the data transfer between the farm management information system and the task controller of an ISO 11783 network

**3.14****destination address****DA**

protocol data unit-specific field in the CAN identifier used to indicate the address of the intended receiver of the CAN message

**3.15****device**

mechanical system such as tractor, trailer or implement, or an independent sensor system

**3.16****device element**

any addressable item on a device

EXAMPLE Nozzle on sprayer boom where the nozzle has individually addressable process data variables.

**3.17****display**

part of a virtual terminal that presents visible information to an operator

**3.18****electronic control unit****ECU**

electronic item consisting of a combination of basic parts, subassemblies and assemblies packaged together as a physically independent entity

EXAMPLE Function controller, network interconnect unit or virtual terminal.

**3.19****equipment**

device or machine that performs a specific field operation

NOTE It can be a tractor or an implement attached to a tractor or self-propelled machine.

**3.20****farm management information system****FMIS**

office computer system used by a farmer or contractor that includes the software for farm management such as book keeping, payroll, resource management for machines, products, workers, field management, geographical information system, decision support systems and task management

**3.21****field**

one or more partfields

NOTE The field is only of importance within the farm management information system for business management considerations and is not necessarily related to a single crop.

**3.22****function**

action or activity by which equipment fulfils one of its intended purposes

**3.23****gateway**

electronic control unit that permits data to be transferred between two networks with different protocols or message sets

NOTE A gateway provides a means to repackage parameters into new message groups when transferring messages from one network to another.

**3.24**

**grid cell**

rectangular areas defined by overlaying a grid on a partfield

**3.25**

**group extension**

protocol data unit-specific field that is used as part of the information necessary to determine the parameter group number

**3.26**

**implement**

device or machine that performs a specific operation and which is normally attached to a tractor

**3.27**

**industry group**

**IG**

allocation of devices and their functions used by a specific industry

**3.28**

**initial address**

source address of a control function in a self-configuring electronic control unit that is determined during initial power up of the ECU and which is used on the subsequent power up

**3.29**

**machine**

device that uses or applies mechanical power, which has a definite function and which performs a specific kind or kinds of work

**3.30**

**management computer gateway**

electronic control unit that interfaces to the management computer system and to the ISO 11783 network

NOTE A management computer gateway can store data for transmission at a later time.

**3.31**

**mask**

top-level object that contains other objects for display on the virtual terminal

**3.32**

**media**

physical entity that conveys the electrical transmission (or equivalent means of communication) between ECUs on the network

NOTE ISO 11783 media consists of quad-twisted copper wires.

**3.33**

**message**

one or more CAN data frames with the same parameter group number

NOTE The information related to a single parameter group number to be transferred on the network can take several CAN data frames.

**3.34**

**mobile implement control system**

devices that are coupled together by, and that use, the ISO 11783 network

**3.35**

**multi-packet message**

message used when more than one CAN data frame is required to transmit all data specific to a given parameter group number

NOTE Each CAN data frame has the same CAN identifier but contains different data in each packet.

**3.36****NAME**

eight-byte entity which provides an indication of each control function of an ECU

NOTE The NAME is used to provide a description of the control function and to provide a numerical value that can be used for arbitration of conflicting addresses.

**3.37****negative-acknowledgement**

response to a message that indicates that it has not been understood or that a requested action cannot be performed

**3.38****network interconnection unit**

electronic control unit used for interconnecting networks or network segments

NOTE Specific implementations for forwarding messages include repeaters, bridges, routers and gateways.

**3.39****node**

physical connection of an ECU to the network

**3.40****non-configurable address**

source address of a control function that can not be altered by any means

**3.41****object pool**

collection of objects that define the operator interface, user interface or device description for an implement or single working set

NOTE A complete virtual terminal interface is composed of one or more object pools — one for each implement or working set.

**3.42****packet**

single CAN data frame of a multi-frame message

NOTE This can also be a message if the data content to be transferred is in one CAN data frame.

**3.43****parameter group****PG**

identification of the data in a single-packet or multi-packet message

NOTE 1 Parameter groups are not dependent on the source address field allowing any source to send any parameter group.

NOTE 2 Parameter groups include data, commands, requests, acknowledgments, and negative-acknowledgments.

NOTE 3 See Annex A for parameter group assignments.

**3.44****parameter group number**

three-byte or 24-bit representation of the data page, protocol data unit format and group extension fields that identifies a particular parameter group

**3.45****partfield**

area characterized by the cultivation of only one agricultural crop

NOTE Partfield is the XML element to which tasks are allocated to obtain smallest granularity.

### **3.46** **PDU format**

eight-bit field in the 29-bit CAN identifier that identifies the format of the protocol data unit

NOTE It is also one of the fields used to determine the parameter group number that labels the data field of the CAN data frame.

### **3.47** **PDU specific** **PS**

eight-bit field in the 29-bit CAN identifier that is either a destination address or group extension

### **3.48** **PDU1 format**

protocol data unit format used for messages which are to be sent to a destination address

NOTE The protocol data unit-specific field contains the destination address (specific or global).

### **3.49** **PDU2 format**

protocol data unit format used to send information by the group extension technique

NOTE The protocol data unit specific field contains the group extension.

### **3.50** **preferred address**

source address of a control function in electronic control units that cannot be changed after device configuration

NOTE Control functions with preferred address are listed in Annex C.

### **3.51** **pixel**

smallest addressable picture element on a virtual terminal display

### **3.52** **polygon**

planar surface, defined by one exterior boundary, and by zero or more interior boundaries

NOTE 1 Each interior boundary describes a hole in the surface.

NOTE 2 A single or group of polygons can be used to define a treatment zone.

### **3.53** **priority**

three-bit field in the CAN identifier that establishes the arbitration priority of the information communicated

NOTE The highest priority is zero and the lowest priority is seven.

### **3.54** **process data message**

message used for the transmission of measured data and/or set point commands to one or more control functions

### **3.55** **process data variable**

information unit that describes an individual characteristic

NOTE Process data variables consist of the attributes range, resolution and units, as defined in the data dictionary.

### 3.56

#### **protocol data unit**

#### **PDU**

ISO 11783-specific CAN data frame

### 3.57

#### **repeater**

electronic control unit that regenerates the data signal to and from another network segment, permitting more electrical loads (i.e. ECU) to be connected or connection to another type of media (physical layer expansion)

NOTE The data rate, protocol and address space are the same on both sides of the repeater.

### 3.58

#### **router**

electronic control unit that connects network segments with independent address space, data rates and media, but which has the same protocol across all network segments

NOTE A router permits a tractor or an implement to appear as a single ECU to other network segments.

### 3.59

#### **segment**

portion of the network using the same physical media

NOTE 1 There is only one path between any two nodes and the data transmitted by any node are available to all other nodes connected to the same segment.

NOTE 2 Multiple segments are connected together by network interconnect units, including gateways, repeaters, bridges and routers.

### 3.60

#### **self-configurable address**

source address of a control function, determined by internal calculations during initial power up of the electronic control unit, which ECU then claims as that address on the network

### 3.61

#### **service-configurable address**

source address of a control function that is changed in operational service mode by using a service tool and any of a number of proprietary techniques, or by using the commanded-address message

### 3.62

#### **soft key mask**

object that contains key data for display on a virtual terminal

### 3.63

#### **source address**

#### **SA**

eight-bit field in the 29-bit CAN identifier that provides for the unique identification of the source of a message

NOTE The source address field contains the address of the control function that is sending the message.

### 3.64

#### **subnetwork**

specific ISO 11783 network segment when multiple segments are used on a device

NOTE 1 Subnetworks can include tractor, implement, hydraulic auxiliary valves and braking system.

NOTE 2 Collectively, the subnetworks are the ISO 11783 system network.

**3.65**

**task**

execution or performance of work on one partfield, for one farm or for one customer

NOTE 1 An operator can activate one task that contains process data variable values for one or more working sets.

NOTE 2 A maximum of one task can be active at the one time on a single task controller.

**3.66**

**task controller**

electronic control unit on the mobile implement control system that is responsible for the sending, receiving and logging of process data

**3.67**

**terminating bias circuit**

**TBC**

circuit required at each end of an ISO 11783 network segment that provides bias voltages for the CAN\_H and CAN\_L signals and the common mode impedance termination for the respective conductors

**3.68**

**tractor**

machine that is the primary source of power in a connected system

NOTE 1 A connected system consists of a tractor and can include one or more implements.

NOTE 2 Self-propelled agricultural equipment or construction equipment include a primary source of power.

**3.69**

**treatment zone**

area to be treated with a constant value of one or more process data variables

NOTE A treatment zone can consist of several grid cells or a polygon with the same treatment parameters.

**3.70**

**vehicle**

machine for the transportation of goods and people on land

**3.71**

**virtual terminal**

**VT**

electronic control unit consisting of a graphical display and input controls providing the capability to display information to and retrieve data from an operator for a connected implement or working set

**3.72**

**visible mask**

active data or alarm mask that is visible on the display of the virtual terminal

**3.73**

**working set**

group of NAMEs in one or more ECUs that collectively provide a control function or group of control functions

NOTE All control functions that are part of a working set, whether or not they are in separate electronic control units, are identified as members by the working-set master.



**3.74****working-set master**

coordinator of the communications of a working set

NOTE 1 The source address of the working-set master is used to identify the working set and, for others, to communicate with the working set.

NOTE 2 The working-set master is identified by a specific control function within a specific electronic control unit.

**3.75****XML element**

element representing an object of the real world

NOTE The extensible markup language element is characterized by a specific name and a definition. It contains several extensible markup language attributes, each with a name and a definition.

**4 Abbreviated terms**

ADIS	agriculture data interface syntax	P	page
AID	attribute identifier	PDU	protocol data unit
BMG	bit mapped graphics	PF	PDU format
BNF	Backus-Naur format	PG	parameter group
CAN	controller area network	PGN	parameter group number
DA	destination address	Pri	priority
DID	device identifier	PS	PDU specific
DTD	document type definition	PS_DA	PDU Specific_Destination Address
DP	data page	PS_GE	PDU Specific_Group Extension
DTF	data transfer file	PTO	power take-off
ECU	electronic control unit	R	reserved
FMIS	farm management information system	RAM	random access memory
GE	group extension	RTB	request to broadcast
GIS	geographical information system	SA	source address
GPS	global positioning system	SLOT	scaling, limits, offset and transfer function
IDn	identification	SPN	suspect parameter number
IDr	identifier	SRR	substitute remote request
IDE	identifier extension bit	TBC	terminating bias circuit
IDN	identification number	Un	undefined
IG	industry group	UTC	coordinated universal time
LSB	least significant byte or least significant bit	VT	virtual terminal
MICS	mobile implement control system	WU	world units
MSB	most significant byte/most significant bit	XML	extensible markup language
NA	not allowed	XSD	XML schema definition
OEM	original equipment manufacturer		
OSI	open system interconnect		

## 5 Application of OSI model to ISO 11783

The open systems interconnection (OSI) specified in ISO 7498 is a model of computer communications architecture having seven layers, as shown in Figure 1 and specified below. It is intended that data communications networks such as the ISO 11783 network be developed to perform the functions of each of the OSI layers, as required.

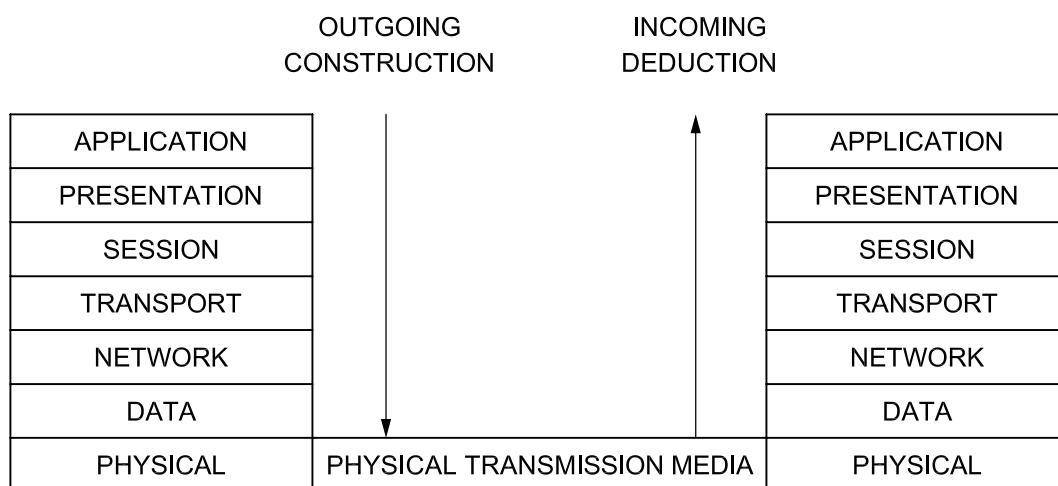

Figure 1 — OSI seven-layer model

### Layer 1 — Physical

This layer concerns the transmission of an unstructured bit stream over physical media; it deals with the mechanical, electrical, functional and procedural characteristics for accessing the physical media.

### Layer 2 — Data Link

This layer provides for the reliable transfer of information across the physical layer; it sends blocks of data with the necessary synchronization, error control, sequence control and flow control.

### Layer 3 — Network

This layer provides upper layers with independence from the data transmission and switching technologies used to connect systems; it is responsible for establishing, maintaining and terminating connections.

### Layer 4 — Transport

This layer provides for reliable, transparent transfer of data between end points, end-to-end error recovery and flow control, and segmentation and reassembly of very large messages.

### Layer 5 — Session

This layer provides the control structure for communication between applications; it establishes, manages and terminates connections (sessions) between cooperating applications.

### Layer 6 — Presentation

This layer provides independence to the application process from differences in data representation (syntax).

### Layer 7 — Application

This layer provides access to the OSI environment for users and also provides distributed information services.

It is not required that any standard based on the model, including ISO 11783, be partitioned explicitly into the seven OSI layers, as long as the fundamental functionality is supported. Not all the OSI layers are required for the ISO 11783 network, because this network is a specific communications system, supporting specific sets of applications for a specific industry. Only those layers required for the anticipated use are defined in ISO 11783, with a separate part of ISO 11783 specifying each of the layers, and with other parts providing functionality support for the layers.

## 6 ISO 11783 network requirements

### 6.1 General

Most messages can be broadcast on an ISO 11783 network. Therefore, the data are transmitted on the network without directing it to a specific destination. This configuration permits any control function within an ECU to use the data without using additional request messages. ISO 11783 also specifies that a specific destination address be included within the CAN identifier of the message when a message is directed to a particular control function. The destination-specific message format is therefore different from the broadcast message format. Proprietary communication is also permitted in ISO 11783, using either destination-specific messages or broadcast message formats.

### 6.2 Physical layer

ISO 11783-2 specifies the physical layer of the data network. The network is composed of a single linear quad-twisted wire cable connected to each ECU at a node. A short cable lead provides a node connection to the quad-twisted wire cable for each ECU. Active terminating bias circuits are specified for each end of a network segment.

ISO 11783-2 also specifies the connectors required for connecting implements to tractors, additional ECUs to an existing network installed on equipment, and a service tool to the network.

ISO 11783-2 also specifies the power sources required for operation of the network and their connections.

A typical ISO 11783 control and communication data network is shown in Figure 2.

### 6.3 Data link layer

ISO 11783 networks use the CAN extended frame format defined in ISO 11898-1 and ISO 11898-2. ISO 11783-3 defines the structure of the CAN identifier for specifying the message formats.

The message formats or protocol data units are used to identify the content of a message. ISO 11783-3 specifies an eight-bit PDU format field, an eight-bit PDU specific field and a two-bit data page field that is used to identify a PDU. To reduce message overhead, ISO 11783-3 specifies that a number of related data items or parameters are to be grouped together within a PDU.

ISO 11783 specifies additional messages for manufacturer proprietary messages.

Messages that need more than eight bytes of data are sent as multi-packet messages. ISO 11783-3 specifies a transport protocol for transmitting multi-packet messages.

Individual application message format definitions, including the message transmission rate, data frame length, data page, PF, PS or DA, and the default priority, are given in that part of ISO 11783 specifying the particular application.

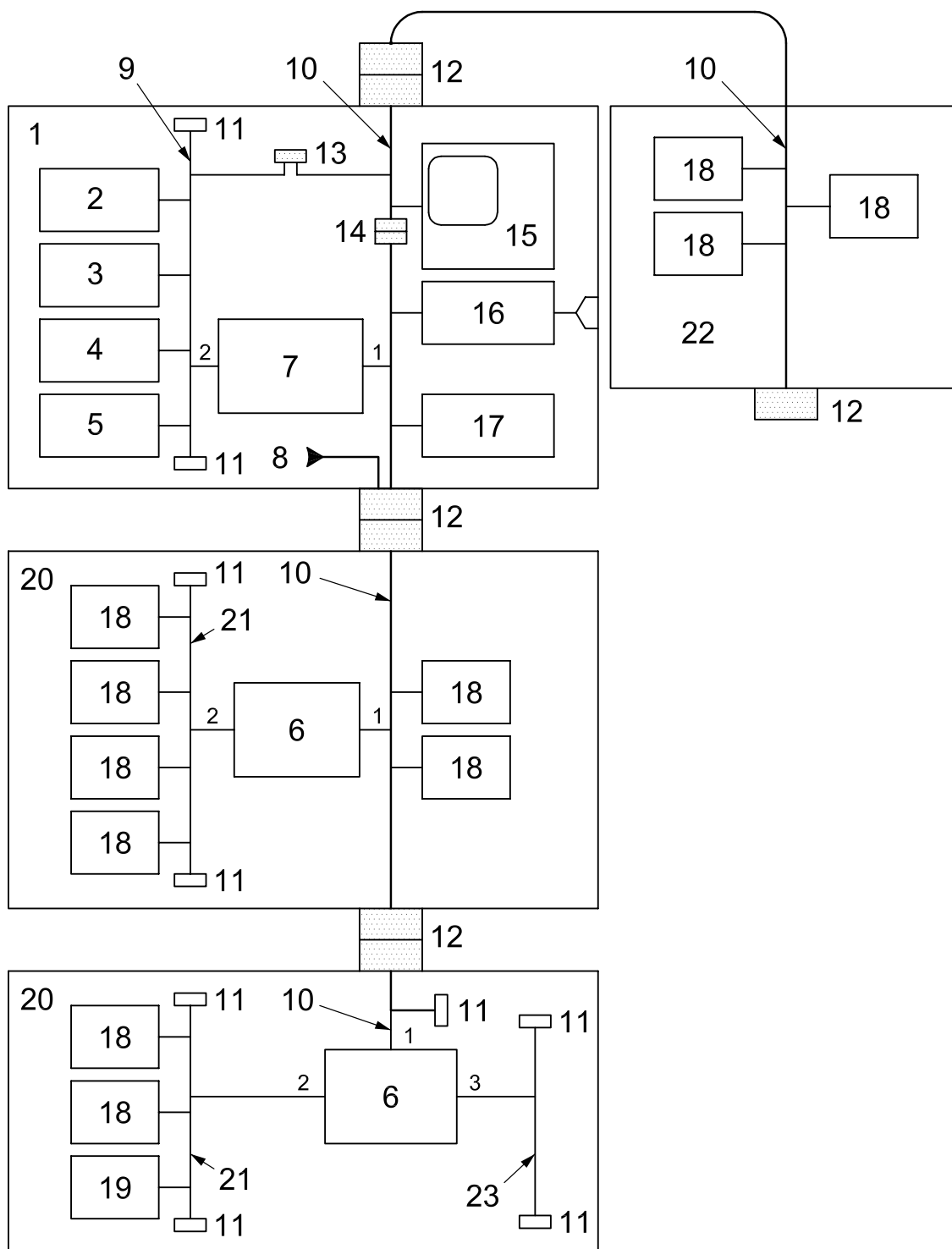

- Key**
- |                             |                                      |                                     |
|-----------------------------|--------------------------------------|-------------------------------------|
| 1 tractor                   | 9 tractor network                    | 17 task controller                  |
| 2 engine                    | 10 implement network                 | 18 ECU                              |
| 3 transmission              | 11 terminator                        | 19 lighting controller              |
| 4 brakes                    | 12 implement bus breakaway connector | 20 rear-mounted or towed implement  |
| 5 hitch controller          | 13 diagnostic connector              | 21 ISO 11783 or other network       |
| 6 network interconnect unit | 14 bus extension connector           | 22 front- or side-mounted implement |
| 7 tractor ECU               | 15 virtual terminal                  | 23 other standard's network         |
| 8 power input               | 16 management computer gateway       |                                     |

NOTE Smaller numbers indicate parts on the interconnect units and tractor ECU.

**Figure 2 — Typical tractor/implement network physical connection structure**

## 6.4 Network layer

When two networks with different network architectures are connected, the integrator of the connected system shall use a network interconnect unit to isolate each network segment from the other. Network interconnect units are detailed in ISO 11783-4. It is also possible that complex systems could require more than the 30-node electrical limit, as specified in ISO 11783-2, on an ISO 11783 network. In these cases, the manufacturer of the implement system shall use network interconnect units to maintain required network electrical load limits.

## 6.5 Network management

Each control function communicating on the ISO 11783 data network requires a source address (SA). There can be a one-for-one relationship of source addresses with ECUs and control functions on the network. If an ECU performs more than one control function, an address is required for each control function.

To uniquely identify each control function, ISO 11783-5 specifies a 64-bit NAME. ISO 11783-5 defines the specific process for determining source addresses and for resolving any address conflicts that can occur. SA are either preset or dynamically claimed by each controller as it powers up.

A NAME shall be assigned to each control function that communicates on an ISO 11783 network. There are examples, such as a virtual terminal and management gateway in a common ECU, where multiple NAMES and addresses coexist within a single ECU. Annex C lists the preset or preferred addresses for non-specific control functions of the industries listed in Annex B. Annex D lists the assigned initial addresses for agriculture and forestry equipment. Annex E and F list the NAMES to be used by control functions on an ISO 11783 data network. Figure 3 illustrates the network topology with different control functions on a tractor and implement. The addresses used by the control functions are also illustrated.

## 6.6 Network segments

### 6.6.1 General

ISO 11783 supports two or more network segments. One segment is identified as the tractor network. This segment is intended to provide the control and data communications for the drive train and chassis of the tractor or primary power unit in a system. The second segment is identified as the implement network that provides the control and data communications between implements, and between implements and the tractor or main power unit in the system. A tractor ECU is required to connect the tractor network and the implement network. Figure 3 illustrates the two network segments connected by a tractor ECU.

### 6.6.2 Tractor network

The tractor network provides the control and data communications between control functions on the drive train and chassis of the tractor. This network segment is controlled by the tractor manufacturer. It is recommended that the tractor network physical layer comply with ISO 11783-2. The tractor network is shown with respect to the implement network on the tractor in Figure 3. Both the tractor network and the implement network can be integrated on-board the tractor. It is intended that control functions not be connected to the tractor network unless consent is given by the tractor manufacturer. The tractor network may use application messages defined in ISO 11783-8 and ISO 11783-7 as well as proprietary messages specified in ISO 11783-3.

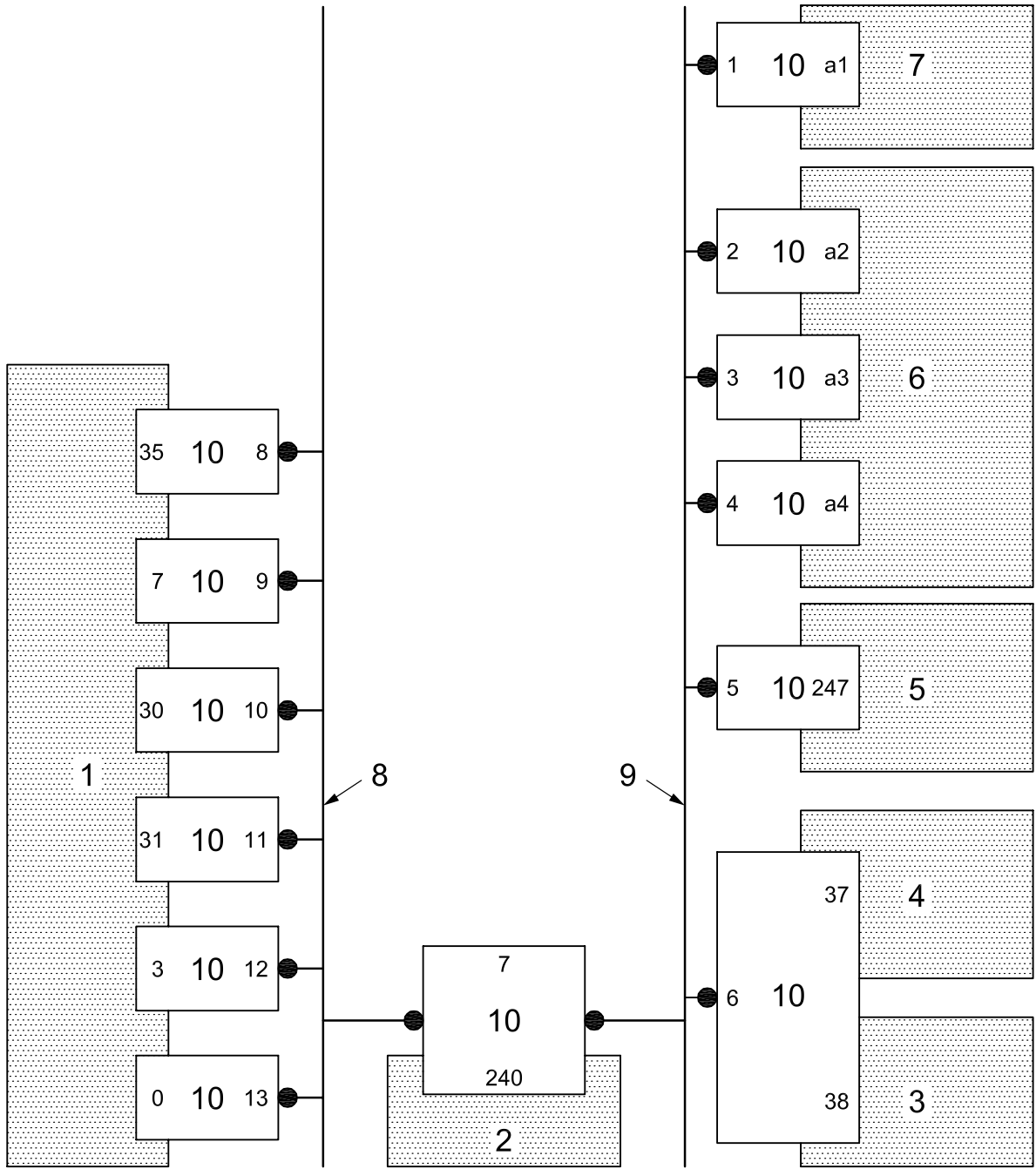

**Key**

 device

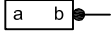
 node

- |                               |                   |  |
|-------------------------------|-------------------|--|
| 1 tractor                     | 5 task controller | 9 implement network                    |
| 2 tractor ECU                 | 6 implement 1     | 10 ECU                                 |
| 3 virtual terminal            | 7 implement 2     | a Control function address.            |
| 4 management computer gateway | 8 tractor network | b ECU containing the control function. |

NOTE 1 a1, a2, a3, a4 are self-configurable addresses.

NOTE 2 The number in smaller type beside each node connection (or, in the case of the tractor ECU, above-centre between nodes) is the ECU containing the control function, while the number or numbers in smaller type opposite it is the function's address.

**Figure 3 — Typical ISO 11783 network topology**

### 6.6.3 Implement network

The implement network shall be designed to support communications between implements and between the tractor and implements. This network segment shall meet the applicable requirements of ISO 11783. The implement network exists on the tractor and on implements as shown in Figure 3. The implement network physical layer connectors shall comply with ISO 11783-2. Application messages for the implement network are defined in ISO 11783-7. Power train messages (see ISO 11783-8) may be used by control function addresses on the implement network.

### 6.6.4 Recommended configuration

It is recommended that the tractor network control functions use the preferred addresses listed in Annex C. The number of control functions used on connected implements shall be limited to the 119 addresses in the address range from 128 to 247 using self-configurable addresses. Practical limitations exist where multiple implements can be connected to the ISO 11783 network. Implement addresses shall be allocated using the process according to ISO 11783-5. The implement shall provide connections for extending the network to additional implements that would be connected in a serial method, as shown in Figure 2. Implements with several ECUs can use a network interconnection ECU that would isolate the additional ECU from the implement network.

## 6.7 Virtual terminal

The virtual terminal is an ECU that provides an operator interface for an implement or tractor using the specified standardized messages of an ISO 11783 network. ISO 11783-6 specifies the requirements of a virtual terminal (VT). The VT shown in Figure 2 is attached to the implement network. The tractor ECU or other ECUs within the tractor that are connected to the implement network can utilize the VT using the same method as for the implement ECU.

## 6.8 Tractor ECU

A network interconnect unit shall be provided between the tractor and the implement networks to assure both electrical and message isolation. If both networks are included in a system, manufacturers of the tractor or main power unit may use the tractor ECU or a similar unit to receive requests for messages listed in ISO 11783-7 from implement control functions. This ECU interprets the requests from the implement network and, in turn, communicates with the ECUs on the tractor network. The tractor ECU shall provide appropriate acknowledgments or responses to the requesting or commanding ECU, and shall provide the basic information and act on command messages in accordance with ISO 11783-9.

## 6.9 Task controllers

Task controllers provide scheduled control of implement functions via the ISO 11783 network. Task data received by the farm management computer interface is stored in the task controller. These tasks are scheduled by the task controller, which sends control messages to the appropriate control function for execution on the implement network. The task controller also records data received from control functions as tasks are being completed. This data is transferred to the farm management computer through the farm management computer interface on the implement network. The operation of the task controller and the format of messages sent to, and received from, control functions are defined in ISO 11783-10. The definition of the data elements used in the task controller messages is specified in a data dictionary given in ISO 11783-11.

## 6.10 Farm management computer interface

A farm management computer interface may be provided on the implement network. The physical interface of the gateway for the management computer is not specified in ISO 11783. Messages defined in ISO 11783-10 shall be used to provide data derived from files on a management computer to the management computer interface. See Figures 2 and 3.

## 6.11 Diagnostics

ISO 11783-12<sup>2)</sup> specifies the messages to be used to determine the source of any faults that are the cause of malfunctioning of the ISO 11783 serial control and data communications network. The messages are also specified in other referenced diagnostics standards.

## 6.12 File server

ISO 11783-13<sup>3)</sup> specifies an ECU that provides storage for data files and a set of commands that a control function on the ISO 11783 serial control and data communications network will use to access or write data from/to these files.

## 6.13 Process data

The process data message is used for the transmission of data to one or more control functions from the task controller. The message can also be used for transmitting data to another control function connected to the implement network. Process data message structure is defined in ISO 11783-7. The data definitions are in the data dictionary given in ISO 11783-11.

## 6.14 Working sets

### 6.14.1 General

A working set allows communications among units on a network where several control functions are acting as distributed processes providing a single application. These several control functions, each with a distinct NAME, can be in different ECUs connected by different nodes. Working sets are used in ISO 11783 where several dissimilar NAMES, possibly within different ECUs, are intended to co-operate as a single implement. The working set allows the use of a single address as a subset of the “global” destination for one-to-many communications, and to permit the receiver of many-to-one communications to associate each of the many control functions with all the others that form the particular working set. The format for the communications becomes one-to-one in each case, with all data for the working set sent to the address of the network NAME that has identified itself as the working-set master. All members of the working set listen to messages addressed to the master as though those messages were individually sent to each member. Messages, such as displayed data, sent by members of the working set are associated with the whole working set. The response to a request by a member of a working set shall be sent to the working-set master and is thereby heard by all of the members of the working set. This relieves the message loading where there is a distribution of functionality and reduces the work required of a control function that needs to send commands or other *destination-specific* messages to all of the members of the working-set. Working-set masters and members require the capability to identify when non-working-set messages, such as programming operations or fault table erasure commands that are specific to the master, are not applied to the entire working set.

**EXAMPLE 1** Working sets are used in ISO 11783 when several NAMES (not necessarily within different ECUs) on an implement such as a planter communicate with the virtual terminal so that the VT interprets that all of the working-set NAMES are providing data as a single VT entity.

**EXAMPLE 2** A task controller has to command several NAMES to control to a single new set point value. When these NAMES are all members of a working set, sending this command to the working-set master accomplishes the same action as a series of commands sent to each of the individual NAMES in the set.

Two message types are required to define the working set. The first message defines the working set's size, the second identifies the members of the set. The master transmits both of these messages. The two messages are defined in ISO 11783-7.

The term “collaborator” is a network control function — whether in a single ECU or one control function of many within an ECU — that works with working sets and communicates with the set as a separate entity. It is not a member of the working set being described, but can be a member or master of another working set.

---

2) To be published.



### 6.14.2 Working-set application rules

The working-set application rules are the following.

- a) A working-set-master message shall always be followed by the appropriate number of working-set-member messages. The number of working-set-member messages is one less than working-set size. A collaborator of the working set that does not receive the correct number of member definitions shall request the working-set-master PGN from the master of the set. This means that the master shall completely define the set on receipt of this request. Applications that do not work with working sets may ignore the working-set messages and communicate directly with all other network devices.
- b) Working sets shall be defined by the NAMEs of the working-set members. Working-set-member messages are sent at an interval of about 100 ms. If more than 350 ms has elapsed after a working-set-member message, the receiver shall assume that the working-set master has completed sending all the NAMEs of the working-set members.
- c) Working-set members are also individual control functions on the network, and therefore communicate as individual control functions. Fault messages will be sent from the control function's SA, and any commands to clear fault tables, program parameters, and others shall be addressed to the individual SA of the intended control function. Working-set members shall be programmed to allow for such individual communications to the working-set master without having all the working-set members accepting programming not intended for them. While it is possible that programming of common data into all members of the working set is intended, this is not the most likely occurrence and requires that the member NAMEs have application software to allow this to happen. Control functions that do not work with working sets may ignore working-set messages and communicate directly with all other network NAMEs.
- d) Each NAME on the network shall not be a member of more than one working set. If an existing working-set master issues a new working-set-master message, collaborators of working sets on the network shall replace the old working-set definition with the new definition. A working-set master shall be responsible for re-defining their working set if changes are needed, and it shall send a working-set-master message with data of zero if the working set's purpose is no longer required.
- e) The working-set master shall create a new working set when it changes its NAME. The old working set will no longer exist, but its definition can remain in the memory of the collaborator unit until a clean-up is performed using the method specified in d) by sending a working-set-master message with data of zero. The collaborator of the working set has the responsibility for detecting and correcting duplication of members of a set. Collaborators of working sets shall periodically check for duplications and for unused working sets in order to recover the internal memory used for those sets that are no longer active.
- f) A change in the SA of the working-set master does *not* change the definition of the set. The collaborators shall update the association of SA to NAME when the new address claim is received, and the working-set members shall change the address that they will use to receive working-set communications.
- g) The collaborators of working sets shall associate a new SA with the appropriate working set when a working-set member changes its SA. Since the working-set members are defined by NAME, the SA change, assuming that the NAME is unchanged, can be handled by the working-set collaborators as they receive new address claim messages.
- h) It is the responsibility of the working-set master to account for all of the NAMEs of members of the working set. The master shall revise the working-set definition when new members join the network. Collaborators shall create the working set with the total number of members as specified in the working-set-member messages, and then add the SA of members as they claim addresses. This process is similar to the above process of changing the SA of a member that is active but which has changed its SA because of a later address claim by another function.

### **6.15 Safe mode operation**

Control functions, designed according to the requirements of this standard, provide information and controls in messages sent to a virtual terminal, an auxiliary controller or a task controller as specified in this standard. Manufacturers (see Annex G for codes) shall ensure that the controls requested of a virtual terminal, an auxiliary controller or a task controller are designed and constructed according to applicable safety standards. The functions provided by the controller(s) shall be designed such that the desired effect(s) shall occur and not result with a risk of injury.

ISO 11783-9 specifies additional safe mode operations requirements.

### **6.16 Addition of parameters and messages**

Implement messages for communications between implements and a tractor are specified in ISO 11783-7. ISO 11783-8 specifies the messages for the tractor power train.

Message sets developed for specific applications can be added to ISO 11783. Proposed message sets shall be submitted to ISO TC 23/SC 19's Working Group WG 1 using the forms provided in Annex H. The Working Group, after review and any necessary revision, forwards the recommended message set to the Subcommittee as a proposed addition to either ISO 11783-7, ISO 11783-8, ISO 11783-9 or ISO 11783-10<sup>3)</sup>. All ISO 11783 parameters and messages are registered in the SAE J 1939 database at the request of WG 1.

---

3) To be published.

## Annex A (normative)

### Parameter group assignments

For the purposes of this annex, the following abbreviations are used:

DP	data page (1 bit)	GE	group extension (8 bits)
PF	PDU format (8 bits)	DA	destination address (8 bits)
PS	PDU specific (8 bits) (either DA or GE)	MP	multi-packet allowed (Yes or No)
PGN	parameter group number (3 bytes) (see ISO 11783-3 for a description)	1939- <i>n</i>	number of applicable SAE J 1939 standard

NOTE The DA cannot be defined before a receiver of the message is determined by the real-time operating software that is sending the message. So this 8-bit frame is simply designated as a DA. GE is the extension added to the PF and the DP to identify the PGN which in turn identifies the message contents. For PFs greater than 139, the GE is used to make up the PGN. PF of 139 and lower use 0 for the GE, as this field is being used for the DA. See ISO 11783-3 for a detailed explanation of the relationship between those elements.

DP	PF	PS	PGN	Parameter Group Label	Acronym	MP	PGN Doc	Description
0	0	DA	0	Torque/Speed Control 1	TSC1	No	1939-71	
0	1	DA	256	Transmission Control 1	TC1	No	1939-71	
0	2	DA	512	Reserved for ISO 11992	EBS11	No	ISO 11992	
0	3	DA	768	Reserved for ISO 11992	EBS21	No	ISO 11992	
0	4	DA	1024	External Brake Request	XBR	No	1939-71	Used for brake control by an external device
0	5	DA	1280	Reserved for CANopen	CAM11	No	ISO 11992	CAN open Application Message #1/1
0	6	DA	1536	Reserved for CANopen	CAM21	No	ISO 11992	CAN open Application Message #2/1
0	7	DA	1792	General Purpose Valve Load Sense Pressure	GPV4	No	ISO 11783-7	Measurement of load sense and pilot pressure of a general-purpose valve

0 170	DA	43520	Client to File Server message		No	ISO 11783-7	File server message from a client on the network
0 171	DA	43776	File Server to client message		No	ISO 11783-7	File server message to a client on the network
0 172	DA	44032	Guidance System Machine Information	GMS	No	ISO 11783-7	Machine system feedback detailing status of machine relative to guidance operation
0 173	DA	44288	Guidance System Command	GMC	No	ISO 11783-7	Steering command expressed as desired curvature
0 174	DA	44544	Tyre Pressure Reference Setting	TPRS	No	1939-71	Message used for setting the tyre pressure reference values
0 175	DA	44800	Parameter Locate Message	PLM	No	1939-74	Message that causes other control functions to respond with the identity of any message that they send in which the particular parameter (identified by specific SPN) is contained
0 176	DA	45056	Configuration Identification Message	CIM	No	1939-74	Message used to identify the data content (by SPN) of one of the configurable messages (identified by PGN)
0 177	DA	45312	Proprietarily Configurable Message #1	PCM1	Yes	1939-74	Proprietarily configuration message for use in SAE J 1939-74
0 178	DA	45568	Proprietarily Configurable Message #2	PCM2	Yes	1939-74	Proprietarily configuration message for use in SAE J 1939-74
0 179	DA	45824	Proprietarily Configurable Message #3	PCM3	Yes	1939-74	Proprietarily configuration message for use in SAE J 1939-74
0 180	DA	46080	Proprietarily Configurable Message #4	PCM4	Yes	1939-74	Proprietarily configuration message for use in SAE J 1939-74
0 181	DA	46336	Proprietarily Configurable Message #5	PCM5	Yes	1939-74	Proprietarily configuration message for use in SAE J 1939-74
0 182	DA	46592	Proprietarily Configurable Message #6	PCM6	Yes	1939-74	Proprietarily configuration message for use in SAE J 1939-74
0 183	DA	46848	Proprietarily Configurable Message #7	PCM7	Yes	1939-74	Proprietarily configuration message for use in SAE J 1939-74
0 184	DA	47104	Proprietarily Configurable Message #8	PCM8	Yes	1939-74	Proprietarily configuration message for use in SAE J 1939-74
0 185	DA	47360	Proprietarily Configurable Message #9	PCM9	Yes	1939-74	Proprietarily configuration message for use in SAE J 1939-74
0 186	DA	47616	Proprietarily Configurable Message #10	PCM10	Yes	1939-74	Proprietarily configuration message for use in SAE J 1939-74
0 187	DA	47872	Proprietarily Configurable Message #11	PCM11	Yes	1939-74	Proprietarily configuration message for use in SAE J 1939-74
0 188	DA	48128	Proprietarily Configurable Message #12	PCM12	Yes	1939-74	Proprietarily configuration message for use in SAE J 1939-74
0 189	DA	48384	Proprietarily Configurable Message #13	PCM13	Yes	1939-74	Proprietarily configuration message for use in SAE J 1939-74
0 190	DA	48640	Proprietarily Configurable Message #14	PCM14	Yes	1939-74	Proprietarily configuration message for use in SAE J 1939-74

0 191	DA	48896	Proprietary Configurable Message #15	PCM15	Yes	1939-74	Proprietary configuration message for use in SAE J 1939-74
0 192	DA	49152	Proprietary Configurable Message #16	PCM16	Yes	1939-74	Proprietary configuration message for use in SAE J 1939-74
0 193	DA	49408	Diagnostic Readiness 2	DR2	No	1939-73	Message to convey information relevant to the readiness of the OBD system
0 194	DA	49664	Reserved for DM20	DM20	Yes	1939-73	Reserved for DM20
0 195	DA	49920	Clear/Reset Active and Previously Active DTC	DM21	No	1939-73	Individual clear/reset of active and previously active DTC
0 196	DA	50176	General Purpose Valve Command	GPV3	No	ISO 11783-7	Controls the flow through a general purpose valve
0 197	DA	50432	General Purpose Valve Measured Flow	GPV2	No	ISO 11783-7	Measurement of the flow through a general purpose valve
0 198	DA	50688	General Purpose Valve Estimated Flow	GPV1	No	ISO 11783-7	Estimated flow through of a general purpose valve
0 199	DA	50944	Extended Transport Protocol – Data Transfer	ETP.DT	Yes	ISO 11783-6	Defined in ISO 11783-6
0 200	DA	51200	Extended Transport Protocol – Connection Mgt	ETP.CM	No	ISO 11783-6	Defined in ISO 11783-6
0 201	DA	51456	Request 2	RQST2	No	ISO 11783-3	Requests a PGN from network control function or functions and to specify whether the response can or cannot use the Transfer PGN and data set for all control functions it is tasked with reporting.
0 202	DA	51712	Transfer	XFER	No	ISO 11783-3	PGN that provides a mechanism for reporting multiple data sets for a given PGN
0 203	DA	51968	Process Data Message	PD	No	ISO 11783-7	Message defined as destination specific and the sender shall determine which implement receives the message
0 204	DA	52224	Request for Repetition Rate	REQRR	No	ISO 11783-7	Message allowing the system to adapt the network bandwidth to the needs of the user of messages
0 205	DA	52480	Reserved for ISO 15765 KWP2000	KWP4	No	ISO 15765	Mixed functional addressing
0 206	DA	52736	Reserved for ISO 15765 KWP2000	KWP3	No	ISO 15765	Mixed physical addressing
0 207	DA	52992	Continuous Torque & Speed Limit Request	CTL	No	1939-71	
0 208	DA	53248	Cab Illumination Message	CL	No	1939-71	Message contains information that controls illumination sources inside the vehicle's cab
0 209	DA	53504	Air Suspension Control 6	ASC6	No	1939-71	Used for suspension control
0 210	DA	53760	Air Suspension Control 2	ASC2	No	1939-71	Used for suspension control
0 211	DA	54016	Calibration Information	DM19	Yes	1939-73	Information about the calibration to scan tool

0 212	DA	54272	Data Security	DM18	Yes	1939-73
0 213	DA	54528	Time/Date Adjust	TDA	No	1939-71
0 214	DA	54784	Boot Load Data	DM17	Yes	1939-73
0 215	DA	55040	Binary Data Transfer	DM16	Yes	1939-73
0 216	DA	55296	Memory Access Response	DM15	No	1939-73
0 217	DA	55552	Memory Access Request	DM14	Yes	1939-73
0 218	DA	55808	Reserved for ISO 15765	KWP2	No	ISO 15765
0 219	DA	56064	Reserved for ISO 15765	KWP1	No	ISO 15765
0 220	DA	56320	Anti-theft Status	ATS	No	1939-71
0 221	DA	56576	Anti-theft Request	ATR	Yes	1939-71
0 222	DA	56832	Reset	RESET	No	1939-71
0 223	DA	57088	Diagnostic Message #13	DM13	No	1939-73
0 224	DA	57344	Cab Message 1	CM1	No	1939-71
0 225	DA	57600	Reserved for ISO 11992	GFM21	No	ISO 11992
0 226	DA	57856	Reserved for ISO 11992	GFM11	No	ISO 11992
0 227	DA	58112	Diagnostic Message #7	DM7	No	1939-73
0 228	DA	58368	Reserved for ISO 11992	RGE11	No	ISO 11992
0 229	DA	58624	Reserved for ISO 11992	RGE21	No	ISO 11992
0 230	DA	58880	Virtual Terminal-to-Working Set	VT12	Yes	ISO 11783-6
0 231	DA	59136	Working Set-to-Virtual Terminal	VT21	Yes	ISO 11783-6
0 232	DA	59392	Acknowledgment Message	ACKM	No	ISO 11783-3
0 234	DA	59904	Request	RQST	No	ISO 11783-3
0 235	DA	60160	Transport Protocol – Data Transfer	TP.DT	No	ISO 11783-3

Message that stop or start broadcast messages — can be on networks other than ISO 11783 network

Message containing parameters originating from a vehicle cab

Acknowledgment PG that provides a handshake mechanism between transmitting and receiving control functions

Provides the capability to request information globally or from a specific destination as identified by the PGN

Used for the transfer of data associated with parameter groups with more than 8 bytes of data

0 236 DA 60416	Transport Protocol — Connection Mgmt	TP_CM.xx	No	ISO 11783-3	Used for the transfer of parameter groups with 9 or more bytes of data
0 237 DA 60672	Network Layer	N.xx	Yes	ISO 11783-4	
0 238 DA 60928	Address Claimed Message	AC	No	ISO 11783-5	Used to claim an address for a control function
0 239 DA 61184	Proprietary A	PropA	Yes	ISO 11783-3	Proprietary PG using the destination specific PDU format to allow manufacturers to direct their proprietary communications to a specific destination node
0 240 0 61440	Electronic Retarder Controller 1	ERC1	No	1939-71	Message transmitted by several types of retarding controllers
0 240 1 61441	Electronic Brake Controller 1	EBC1	No	1939-71	Used for brake control information
0 240 2 61442	Electronic Transmission Controller 1	ETC1	No	1939-71	
0 240 3 61443	Electronic Engine Controller 2	EEC2	No	1939-71	
0 240 4 61444	Electronic Engine Controller 1	EEC1	No	1939-71	Engine related parameters
0 240 5 61445	Electronic Transmission Controller 2	ETC2	No	1939-71	
0 240 6 61446	Electronic Axle Controller 1	EAC1	No	1939-71	
0 240 7 61447	Forward Lane Image urgent message	FLI1	No	1939-71	
0 240 8 61448	Hydraulic Pressure Governor Info	HPG	No	1939-71	Information used for a hydraulic pressure governing control system
0 240 9 61449	Vehicle Dynamic Stability Control 2	VDC2	No	1939-71	Contains information which relates to the vehicle's movement
0 240 10 61450	Engine Gas Flow Rate	EGF1	No	1939-71	Low rates of air and mixed gasses into the engine cylinders
0 240 11 61451	Electronic Steering Control	ESC1	No	1939-71	PGN that indicates the actual angle and the status of a steerable axle
0 240 12 61452	Electronic Transmission Controller #8	ETC8	No	1939-71	Electronic transmission controller #8
0 240 13 61453	Land Levelling System Operational Information	LOI	No	1939-71	Group of operational parameters associated with the land levelling system, such as switch states
0 240 14 61454	After Treatment Intake Gas 1		No	1939-71	

0	240	15	61455	After Treatment Outlet Gas 1	No	1939-71				
0	240	16	61456	After Treatment Intake Gas 1-b	No	1939-71				
0	240	17	61457	After Treatment Outlet Gas 1-b	No	1939-71				
0	240	18	61458	Fifth Wheel Smart Systems 1	FWSS1	1939-71			Message for determining the status of the tractor to trailer coupling system integrity	
0	240	19	61459	Slope Sensor Information	SSI	1939-71			Slope sensor information	
0	253	171	64939	Complete Configurable Message Set Request	RCMS	1939-71			Request for all ECUs to send the complete sequence of configuration identification messages for a particular one or all of the configurable messages that they send	
0	253	172	64940	Rotational Sensor Angle	RSA	1939-71			Message of the measurement of a rotation angle around a single axis	
0	253	173	64941	Reserved		1939-71			Reserved for future assignment	
0	253	174	64942	Fifth Wheel Smart Systems 2	FWSS2	1939-71			Message used to convey operator parameters associated with the tractor to trailer coupling control and error state	
0	253	175	64943	After Treatment Intermediate Gas 1-b		1939-71				
0	253	176	64944	After Treatment Outlet Gas 2-b		1939-71				
0	253	177	64945	After Treatment Intake Gas 2-b		1939-71				
0	253	178	64946	After Treatment Intermediate Gas 1		1939-71				
0	253	179	64947	After Treatment Outlet Gas 2		1939-71				
0	253	180	64948	After Treatment Intake Gas 2		1939-71				
0	253	181	64949	Previous Active Emission Related Faults		1939-71				
0	253	182	64950	SPN Support		1939-71				
0	253	183	64951	Expanded Freeze Frame		1939-71				
0	253	184	64952	Diagnostic Readiness 3		1939-71				
0	253	185	64953	Tyre Pressure Reference Information	TPRI	1939-71			Information on actual tyre pressure reference value for monitoring	
0	253	186	64954	Farebox Status	TR6	1939-71			Used to report alarms of the fare collection unit	
0	253	187	64955	Farebox Point of Sale	TR5	1939-71			Used to report stop-level point of sale detail	



0 253 188	64956	Farebox Service Detail	TR4	Yes	1939-71	Used to identify service, assignments and fare preset detail of the fare collection unit
0 253 189	64957	Signal Pre-emption	TR3	No	1939-71	Status and configuration of the controller used for intersection pre-emption
0 253 190	64958	Transit Route	TR1	Yes	1939-71	Current route assigned to this transit vehicle
0 253 191	64959	Transit Milepost	TR2	Yes	1939-71	Identification of a transit route milepost
0 253 192	64960	Passenger Counter	TR7	No	1939-71	Used to notify the transit link controllers of the passenger count
0 253 193	64961	Engine Fluid Level/Pressure 3	EFL/P3	No	1939-71	
0 253 196	64964	Electronic Brake Controller 5	EBC5	No	1939-71	Message containing information on brake control
0 253 197	64965	ECU Identification Information	ECUID	Yes	1939-71	Message for reporting identification and information about the physical ECU and its hardware
0 253 198	64966	Cold Start Aids		No	1939-71	Cold start aid information and settings
0 253 199	64967	Off-Highway Engine Control Selection States	OHCSS	No	1939-71	Reports the states of off-highway engine control modes, as they apply to different modes of engine operation which can be used to aid particular working environments
0 253 200	64968	Operator Primary Intermediate Speed Control	ISCS	No	1939-71	Used to provide the controller feedback to indicate the controls state achieved
0 253 201	64969	Electronic Control Module Information	CMI	Yes	1939-71	Information relating to electronic control modules
0 253 202	64970	Intermediate Speed Control	ISC	No	1939-71	Message that addresses the particular needs of the industrial engine operational functionality concerning the intermediate speed control operation
0 253 203	64971	Off-Highway Engine Control Selection	OHECS	No	1939-71	Allows for the selection of off-highway engine control modes, as they apply to different modes of engine operation which can be used to aid particular working environments
0 253 204	64972	Operators External Light Controls Message	OEL	No	1939-71	Message containing the information about the position of the operator's external light control switch(s)
0 253 205	64973	Operator Wiper and Washer Controls Message	OWW	No	1939-71	Message for items related to the operators controls for the window wipers and washers on the front and rear cab windows
0 253 206	64974	Working Set Member Message	WSMM	No	1939-81	Message sent by the master of a working set to identify an individual member of a specific working set

0 253 207	64975	Working Set Master Message	WSM	No	1939-81	Message sent by the master of a working set that identifies the number of individual members of the working set
0 253 208	64976	Inlet/Exhaust Conditions 2	IC2	No	1939-71	Second PGN conveying this type of engine information (see also PGN 65270)
0 253 209	64977	FMS-standard Interface Identity/Capabilities	FMS	No	1939-71	Information that specifies the capabilities of the fleet management system (FMS) — standard interface unit
0 253 210	64978	ECU Performance	EP	No	1939-71	Message used to transfer ECU performance parameters
0 253 211	64979	Turbocharger Information 6	TCI6	No	1939-71	Turbocharger compressor outlet discharge temperature
0 253 212	64980	Cab Message 3	CM3	No	1939-71	Provides information from cab-mounted operator inputs
0 253 213	64981	Electronic Engine Controller 5	EEC5	No	1939-71	Engine-related parameters
0 253 214	64982	Basic Joystick Message 1	BJM1	No	1939-71	Used to transfer information about the measured status of the first two axes and up to 12 buttons of a joystick
0 253 215	64983	Extended Joystick Message 1	EJM1	No	1939-71	Used to transfer information about the measured status of three additional axes of a joystick and switches of the joystick grip or handle
0 253 216	64984	Basic Joystick Message 2	BJM2	No	1939-71	Used to transfer information about the measured status of the first two axes and up to 12 buttons of a joystick
0 253 217	64985	Extended Joystick Message 2	EJM2	No	1939-71	Used to transfer information about the measured status of three additional axes of a joystick and switches of the joystick grip or handle
0 253 218	64986	Basic Joystick Message 3	BJM3	No	1939-71	Used to transfer information about the measured status of the first two axes and up to 12 buttons of a joystick
0 253 219	64987	Extended Joystick Message 3	EJM3	No	1939-71	Used to transfer information about the measured status of three additional axes of a joystick and switches of the joystick grip or handle.
0 253 220	64988	Marine Control Information	MCI	No	1939-71	Message that contains marine vessel control information for the engine
0 253 221	64989	Military Application Tractor — Trailer	MAM11	No	ISO 11992	Tractor-to-trailer message for military applications using ISO 11992
0 253 222	64990	Military Application Trailer — Tractor Feedback	MAM21	No	ISO 11992	Feedback message from trailer to tractor for military applications using ISO 11992

0 253 223	64991	Front Wheel Drive Status	FWD	No	1939-71	Front wheel drive ECU information
0 253 224	64992	Ambient Conditions 2	AMB2	No	1939-71	Message containing measurement and configuration information about the vehicle ambient conditions
0 253 225	64993	Cab A/C Climate System Information	CACI	No	1939-71	Message containing measurement and condition information from cab air conditioning components
0 253 226	64994	Supply Pressure Demand	SPR	No	1939-71	Used for controlling the supply pressure and often used to raise the pressure of a supply pressure circuit in situations where more pneumatic energy is needed
0 253 227	64995	Equipment Operation and Control	EOAC	No	1939-71	Parameters related to the operation and controls for equipment
0 253 228	64996	Equipment Performance Data	EPD	No	1939-71	Parameters related to the performance characteristics of equipment
0 253 229	64997	Maximum Vehicle Speed Limit	MVS	No	1939-71	Status reports the possible maximum vehicle speed limits, one through seven, and the applied maximum vehicle speed limit
0 253 230	64998	Hydraulic Braking System	HBS	No	1939-71	Used for information on a hydraulic brake system
0 253 231	64999	Bus #1 Utility Sync Check Status	BUSC	No	1939-75	
0 253 232	65000	Bus #1 Generator Sync Check Status	BGSC	No	1939-75	
0 253 233	65001	Bus #1 Phase C Basic AC Quantities	BPCAC	No	1939-75	
0 253 234	65002	Bus #1 Phase B Basic AC Quantities	BPBAC	No	1939-75	
0 253 235	65003	Bus #1 Phase A Basic AC Quantities	BPAAC	No	1939-75	
0 253 236	65004	Bus #1 Average Basic AC Quantities	BAAC	No	1939-75	
0 253 237	65005	Utility Total AC Energy	UTACE	No	1939-75	
0 253 238	65006	Utility Phase C AC Reactive Power	UPCACR	No	1939-75	
0 253 239	65007	Utility Phase C AC Power	UPCACP	No	1939-75	
0 253 240	65008	Utility Phase C AC Basic Quantities	UPCAC	No	1939-75	
0 253 241	65009	Utility Phase B AC Reactive Power	UPBACR	No	1939-75	
0 253 242	65010	Utility Phase B AC Power	UPBACP	No	1939-75	
0 253 243	65011	Utility Phase B AC Basic Quantities	UPBAC	No	1939-75	
0 253 244	65012	Utility Phase A AC Reactive Power	UPACCR	No	1939-75	

0	253 245	65013	Utility Phase A AC Power	UPAACP	No	1939-75
0	253 246	65014	Utility Phase A Basic AC Quantities	UPAAC	No	1939-75
0	253 247	65015	Utility Total AC Reactive Power	UTACR	No	1939-75
0	253 248	65016	Utility Total AC Power	UTACP	No	1939-75
0	253 249	65017	Utility Average Basic AC Quantities	UAAC	No	1939-75
0	253 250	65018	Generator Total AC Energy	GTACE	No	1939-75
0	253 251	65019	Generator Phase C AC Reactive Power	GPCACR	No	1939-75
0	253 252	65020	Generator Phase C AC Power	GPCACP	No	1939-75
0	253 253	65021	Generator Phase C Basic AC Quantities	GPCAC	No	1939-75
0	253 254	65022	Generator Phase B AC Reactive Power	GPBACRP	No	1939-75
0	253 255	65023	Generator Phase B AC Power	GPBACP	No	1939-75
0	254 0	65024	Generator Phase B Basic AC Quantities	GPBAC	No	1939-75
0	254 1	65025	Generator Phase A AC Reactive Power	GPAACR	No	1939-75
0	254 2	65026	Generator Phase A AC Power	GPAACP	No	1939-75
0	254 3	65027	Generator Phase A Basic AC Quantities	GPAAC	No	1939-75
0	254 4	65028	Generator Total AC Reactive Power	GTACR	No	1939-75
0	254 5	65029	Generator Total AC Power	GTACP	No	1939-75
0	254 6	65030	Generator Average Basic AC Quantities	GAAC	No	1939-75
0	254 7	65031	Exhaust Temperature	ET	No	1939-71
0	254 8	65032	Required Tractor Facilities message	RTF	No	ISO 11783-7
0	254 9	65033	Tractor Facilities response message	TFR	No	ISO 11783-7
0	254 10	65034	Implement Remote Control Tractor Response	IRCR	No	ISO 11783-7
0	254 11	65035	Implement Remote Control Command	IRC	No	ISO 11783-7

Implements response to task controller or tractor ECU desired tractor classification and facilities

Tractor response to an implement ECU or task controller tractor classification and facilities request

Command that is a task controller or an implement ECU-to-tractor ECU message

Commands from a task controller or an implement ECU-to-tractor ECU

0 254 12	65036	Working Set Member	WSMEM	No	ISO 11783-7	Message sent by the master of a working set to identify an individual member of a specific working set
0 254 13	65037	Working Set Master	WSMSTR	No	ISO 11783-7	Message sent by the master of a working set that identifies the number of individual members of the working set
0 254 14	65038	Response for Repetition Rate	RESRR	No	ISO 11783-7	Global message that is the response of the request of a specific user to change the repetition rate
0 254 15	65039	Language Command	LC	No	ISO 11783-7	Global message informing all ECUs on the ISO 11783 network of the language the operator wants to use, the date and time format and the units of measure to be displayed by the connected system
0 254 16	65040	Auxiliary Valve Number 0 Estimated Flow	AV00EF	No	ISO 11783-7	Message providing the estimated flow of specified auxiliary valve
0 254 17	65041	Auxiliary Valve Number 1 Estimated Flow	AV01EF	No	ISO 11783-7	Message providing the estimated flow of specified auxiliary valve
0 254 18	65042	Auxiliary Valve Number 2 Estimated Flow	AV02EF	No	ISO 11783-7	Message providing the estimated flow of specified auxiliary valve
0 254 19	65043	Auxiliary Valve Number 3 Estimated Flow	AV03EF	No	ISO 11783-7	Message providing the estimated flow of specified auxiliary valve
0 254 20	65044	Auxiliary Valve Number 4 Estimated Flow	AV04EF	No	ISO 11783-7	Message providing the estimated flow of specified auxiliary valve
0 254 21	65045	Auxiliary Valve Number 5 Estimated Flow	AV05EF	No	ISO 11783-7	Message providing the estimated flow of specified auxiliary valve
0 254 22	65046	Auxiliary Valve Number 6 Estimated Flow	AV06EF	No	ISO 11783-7	Message providing the estimated flow of specified auxiliary valve
0 254 23	65047	Auxiliary Valve Number 7 Estimated Flow	AV07EF	No	ISO 11783-7	Message providing the estimated flow of specified auxiliary valve
0 254 24	65048	Auxiliary Valve Number 8 Estimated Flow	AV08EF	No	ISO 11783-7	Message providing the estimated flow of specified auxiliary valve
0 254 25	5049	Auxiliary Valve Number 9 Estimated Flow	AV09EF	No	ISO 11783-7	Message providing the estimated flow of specified auxiliary valve
0 254 26	65050	Auxiliary Valve Number 10 Estimated Flow	AV10EF	No	ISO 11783-7	Message providing the estimated flow of specified auxiliary valve
0 254 27	65051	Auxiliary Valve Number 11 Estimated Flow	AV11EF	No	ISO 11783-7	Message providing the estimated flow of specified auxiliary valve
0 254 28	65052	Auxiliary Valve Number 12 Estimated Flow	AV12EF	No	ISO 11783-7	Message providing the estimated flow of specified auxiliary valve
0 254 29	65053	Auxiliary Valve Number 13 Estimated Flow	AV13EF	No	ISO 11783-7	Message providing the estimated flow of specified auxiliary valve
0 254 30	65054	Auxiliary Valve Number 14 Estimated Flow	AV14EF	No	ISO 11783-7	Message providing the estimated flow of specified auxiliary valve
0 254 31	65055	Auxiliary Valve Number 15 Estimated Flow	AV15EF	No	ISO 11783-7	Message providing the estimated flow of specified auxiliary valve
0 254 32	65056	Auxiliary Valve Number 0 Measured Flow	AV00MF	No	ISO 11783-7	Message providing the measurement of specified auxiliary valve
0 254 33	65057	Auxiliary Valve Number 1 Measured Flow	AV01MF	No	ISO 11783-7	Message providing the measurement of specified auxiliary valve
0 254 34	65058	Auxiliary Valve Number 2 Measured Flow	AV02MF	No	ISO 11783-7	Message providing the measurement of specified auxiliary valve

0	254	35	65059	Auxiliary Valve Number 3 Measured Flow	AV03MF	No	ISO 11783-7	Message providing the measurement of specified auxiliary valve
0	254	36	65060	Auxiliary Valve Number 4 Measured Flow	AV04MF	No	ISO 11783-7	Message providing the measurement of specified auxiliary valve
0	254	37	65061	Auxiliary Valve Number 5 Measured Flow	AV05MF	No	ISO 11783-7	Message providing the measurement of specified auxiliary valve
0	254	38	65062	Auxiliary Valve Number 6 Measured Flow	AV06MF	No	ISO 11783-7	Message providing the measurement of specified auxiliary valve
0	254	39	65063	Auxiliary Valve Number 7 Measured Flow	AV07MF	No	ISO 11783-7	Message providing the measurement of specified auxiliary valve
0	254	40	65064	Auxiliary Valve Number 8 Measured Flow	AV08MF	No	ISO 11783-7	Message providing the measurement of specified auxiliary valve
0	254	41	65065	Auxiliary Valve Number 9 Measured Flow	AV09MF	No	ISO 11783-7	Message providing the measurement of specified auxiliary valve
0	254	42	65066	Auxiliary Valve Number 10 Measured Flow	AV10MF	No	ISO 11783-7	Message providing the measurement of specified auxiliary valve
0	254	43	65067	Auxiliary Valve Number 11 Measured Flow	AV11MF	No	ISO 11783-7	Message providing the measurement of specified auxiliary valve
0	254	44	65068	Auxiliary Valve Number 12 Measured Flow	AV12MF	No	ISO 11783-7	Message providing the measurement of specified auxiliary valve
0	254	45	65069	Auxiliary Valve Number 13 Measured Flow	AV13MF	No	ISO 11783-7	Message providing the measurement of specified auxiliary valve
0	254	46	65070	Auxiliary Valve Number 14 Measured Flow	AV14MF	No	ISO 11783-7	Message providing the measurement of specified auxiliary valve
0	254	47	65071	Auxiliary Valve Number 15 Measured Flow	AV15MF	No	ISO 11783-7	Message providing the measurement of specified auxiliary valve
0	254	48	65072	Auxiliary Valve Number 0 Command	AV00C	No	ISO 11783-7	Message providing control of the flow through the auxiliary valve
0	254	49	65073	Auxiliary Valve Number 1 Command	AV01C	No	ISO 11783-7	Message providing control of the flow through the auxiliary valve
0	254	50	65074	Auxiliary Valve Number 2 Command	AV02C	No	ISO 11783-7	Message providing control of the flow through the auxiliary valve
0	254	51	65075	Auxiliary Valve Number 3 Command	AV03C	No	ISO 11783-7	Message providing control of the flow through the auxiliary valve
0	254	52	65076	Auxiliary Valve Number 4 Command	AV04C	No	ISO 11783-7	Message providing control of the flow through the auxiliary valve
0	254	53	65077	Auxiliary Valve Number 5 Command	AV05C	No	ISO 11783-7	Message providing control of the flow through the auxiliary valve
0	254	54	65078	Auxiliary Valve Number 6 Command	AV06C	No	ISO 11783-7	Message providing control of the flow through the auxiliary valve
0	254	55	65079	Auxiliary Valve Number 7 Command	AV07C	No	ISO 11783-7	Message providing control of the flow through the auxiliary valve
0	254	56	65080	Auxiliary Valve Number 8 Command	AV08C	No	ISO 11783-7	Message providing control of the flow through the auxiliary valve
0	254	57	65081	Auxiliary Valve Number 9 Command	AV09C	No	ISO 11783-7	Message providing control of the flow through the auxiliary valve
0	254	58	65082	Auxiliary Valve Number 10 Command	AV10C	No	ISO 11783-7	Message providing control of the flow through the auxiliary valve
0	254	59	65083	Auxiliary Valve Number 11 Command	AV11C	No	ISO 11783-7	Message providing control of the flow through the auxiliary valve
0	254	60	65084	Auxiliary Valve Number 12 Command	AV12C	No	ISO 11783-7	Message providing control of the flow through the auxiliary valve

0	254	61	65085	Auxiliary Valve Number 13 Command	AV13C	No	ISO 11783-7	Message providing control of the flow through the auxiliary valve
0	254	62	65086	Auxiliary Valve Number 14 Command	AV14C	No	ISO 11783-7	Message providing control of the flow through the auxiliary valve
0	254	63	65087	Auxiliary Valve Number 15 Command	AV15C	No	ISO 11783-7	Message providing control of the flow through the auxiliary valve
0	254	64	65088	Lighting Data	LD	No	ISO 11783-7	Response to the request for lighting data in the lighting command message provided by lighting function controllers on the tractor and attached implements
0	254	65	65089	Lighting Command	LC	No	ISO 11783-7	Global command message from the tractor to all lighting function controllers on the tractor and attached implements
0	254	66	65090	Hitch and PTO Commands	HPTOC	No	ISO 11783-7	Message providing control of the hitch position, PTO shaft set point speed and PTO engagement
0	254	67	65091	Primary or Rear Power Take-off Output Shaft	RPTO	No	ISO 11783-7	Message providing the measurement of the current primary or rear PTO output shaft parameters
0	254	68	65092	Secondary or Front Power Take-off Output Shaft	FPTO	No	ISO 11783-7	Message providing the measurement of the current secondary or front PTO output shaft parameters
0	254	69	65093	Primary or Rear Hitch Status	RHS	No	ISO 11783-7	Message providing the measurement of the current rear hitch parameters
0	254	70	65094	Secondary or Front Hitch Status	FHS	No	ISO 11783-7	Message providing the measurement of the current front hitch parameters
0	254	71	65095	Maintain Power	MP	No	ISO 11783-7	Message requesting the tractor ECU not switch off the power for the next 2 s, sent by any ECU connected to the implement network
0	254	72	65096	Wheel-based Speed and Distance	WBSD	No	ISO 11783-7	Message providing the current measured wheel-based speed that is sent by the tractor ECU to connected systems on the implement network on construction and agricultural implements
0	254	73	65097	Ground-based Speed and Distance	GBSD	No	ISO 11783-7	Message providing the current measured ground speed that is normally sent by the tractor ECU to connected systems on the implement network on construction and agricultural implements
0	254	74	65098	Electronic Transmission Controller 7	ETC7	No	1939-71	Transmission state information
0	254	75	65099	Transmission Configuration 2	TCFG2	Yes	1939-71	Contains transmission configuration information
0	254	76	65100	Military Lighting Command	ML	No	1939-71	Message containing parameters that control military-specific lights
0	254	77	65101	Total Averaged Information	TAVG	No	1939-71	Averages of information accumulated over the life of the engine

0 254 78	65102	Door Control	DC	No	1939-71	Used for door information
0 254 79	65103	Vehicle Dynamic Stability Control 1	VDC1	No	1939-71	Contains information which relates to the VDC system status
0 254 80	65104	Battery Temperature	BT1	No	1939-71	Contains battery temperature information
0 254 81	65105	Adaptive Cruise Control, Operator Input	ACC2	No	1939-71	Operator requested characteristics for the ACC systems operation.
0 254 82	65106	Vehicle Electrical Power 3	VP3	No	1939-71	Vehicle Electrical Power 3
0 254 83	65107	Retarder Continuous Torque & Speed Limit	RTC1	No	1939-71	
0 254 84	65108	Engine Continuous Torque & Speed Limit	ECT1	No	1939-71	
0 254 85	65109	Gaseous Fuel Properties	GFD	No	1939-71	Properties of the gaseous fuel
0 254 86	65110	Tank Information 1	TI1	No	1939-71	Contains information on various tank levels
0 254 87	65111	Air Suspension Control 5	ASC5	No	1939-71	Used for damper stiffness information
0 254 88	65112	Air Suspension Control 4	ASC4	No	1939-71	Used for bellow pressure information
0 254 89	65113	Air Suspension Control 3	ASC3	No	1939-71	Used for height information
0 254 90	65114	Air Suspension Control 1	ASC1	No	1939-71	Used for suspension control information
0 254 91	65115	Forward Lane Image	FLI2	No	1939-71	
0 254 92	65116	ISO 11992 (even) – Running Gear Equipment #2/2 RGE22		No	ISO 11992	Used for suspension information, direction from towed vehicle to towing vehicle
0 254 93	65117	ISO 11992 (odd) – General Purpose Message #1/2 GPM12		No	ISO 11992	Used for power train information, direction from towing vehicle to towed vehicle
0 254 94	65118	ISO 11992 (even) – Running Gear Equipment #2/3 RGE23		No	ISO 11992	Used for tyre monitoring, direction from towed vehicle to towing vehicle
0 254 95	65119	ISO 11992 (odd) – General Purpose Message #1/3 GPM13		No	ISO 11992	Used for power train information, direction from towing vehicle to towed vehicle
0 254 96	65120	ISO 11992 (even) – General Purpose Message #2/3 GPM23		No	ISO 11992	Used for power train control, direction from towed vehicle to towing vehicle
0 254 97	65121	ISO 11992 (odd) – General Purpose Message #1/4 GPM14		No	ISO 11992	Used for power train information, direction from towing vehicle to towed vehicle
0 254 98	65122	ISO 11992 (even) – General Purpose Message #2/4 GPM24		No	ISO 11992	Used for power train control, direction from towed vehicle to towing vehicle



0 254 99	65123	ISO 11992 (odd) – General Purpose Message #1/5 GPM15	No	ISO 11992	Used for power train information, direction from towing vehicle to towed vehicle
0 254 100	65124	ISO 11992 (even) – General Purpose Message #2/5 GPM25	No	ISO 11992	Used for lights information, direction from towed vehicle to towing vehicle
0 254 101	65125	ISO 11992 (odd) – General Purpose Message #1/6 GPM16	No	ISO 11992	Used for general information, direction from towing vehicle to towed vehicle
0 254 102	65126	Battery Main Switch Information	BM	No	1939-71
0 254 103	65127	Climate Control Configuration	CCC	No	1939-71
0 254 104	65128	Vehicle Fluids	VF	No	1939-71
0 254 105	65129	Engine Temperature 3	ET3	No	1939-71
0 254 106	65130	Engine Fuel/lube systems	EFS	No	1939-71
0 254 107	65131	Driver's Identification	DI	Yes	1939-71
0 254 108	65132	Tachograph	TCO1	No	1939-71
0 254 109	65133	Heater Information	HTR	No	1939-71
0 254 110	65134	High-Resolution Wheel Speed	HRW	No	1939-71
0 254 111	65135	Adaptive Cruise Control	ACC1	No	1939-71
0 254 112	65136	Combination Vehicle Weight	CVW	Yes	1939-71
0 254 113	65137	Laser Tracer Position	LTP	No	1939-71
0 254 114	65138	Laser Levelling System Blade Control	LBC	No	1939-71
0 254 115	65139	Laser Receiver Mast Position	LMP	No	1939-71
0 254 116	65140	Modify Levelling System Control Set Point	LSP	No	1939-71
0 254 117	65141	Laser Levelling System Vertical Deviation	LVD	No	1939-71
0 254 118	65142	Laser Levelling System Vertical Position Display Data	LVDD	No	1939-71
0 254 119	65143	Auxiliary Pressures	AP	No	1939-71
0 254 120	65144	Tyre Pressure Control Unit Mode and Status	TP1	No	1939-71
0 254 121	65145	Tyre Pressure Control Unit Target Pressures	TP2	No	1939-71

0	254 122	65146	Tyre Pressure Control Unit Current Pressures	TP3	No	1939-71
0	254 123	65147	Combustion Time 1	CT1	No	1939-71
0	254 124	65148	Combustion Time 2	CT2	No	1939-71
0	254 125	65149	Combustion Time 3	CT3	No	1939-71
0	254 126	65150	Combustion Time 4	CT4	No	1939-71
0	254 127	65151	Combustion Time 5	CT5	No	1939-71
0	254 128	65152	Combustion Time 6	CT6	No	1939-71
0	254 129	65153	Fuel Information 2 (Gaseous)	GF12	No	1939-71
0	254 130	65154	Ignition Timing 1	IT1	No	1939-71
0	254 131	65155	Ignition Timing 2	IT2	No	1939-71
0	254 132	65156	Ignition Timing 3	IT3	No	1939-71
0	254 133	65157	Ignition Timing 4	IT4	No	1939-71
0	254 134	65158	Ignition Timing 5	IT5	No	1939-71
0	254 135	65159	Ignition Timing 6	IT6	No	1939-71
0	254 136	65160	Ignition Transformer Secondary Output 1	ISO1	No	1939-71
0	254 137	65161	Ignition Transformer Secondary Output 2	ISO2	No	1939-71
0	254 138	65162	Ignition Transformer Secondary Output 3	ISO3	No	1939-71
0	254 139	65163	Gaseous Fuel Pressure	GFP	No	1939-71
0	254 140	65164	Auxiliary Analogue Information Auxiliary Analogue Information	AAI	No	1939-71
0	254 141	65165	Vehicle Electrical Power 2	VP2	No	1939-71
0	254 142	65166	Service 2	S2	Yes	1939-71
0	254 143	65167	Supply Pressure 2	SP2	No	1939-71
0	254 144	65168	Engine Torque History	ETH	Yes	1939-71
0	254 145	65169	Fuel Leakage	FL	No	1939-71
0	254 146	65170	Engine Information	EI	No	1939-71
0	254 147	65171	Engine Electrical System/Module Information	EES	No	1939-71

0 254 148	65172	Engine Auxiliary Coolant	EAC	No	1939-71
0 254 149	65173	Rebuild Information	RBI	No	1939-71
0 254 150	65174	Turbocharger Wastegate	TCW	No	1939-71
0 254 151	65175	Turbocharger Information 5	TCI5	No	1939-71
0 254 152	65176	Turbocharger Information 4	TCI4	No	1939-71
0 254 153	65177	Turbocharger Information 3	TCI3	No	1939-71
0 254 154	65178	Turbocharger Information 2	TCI2	No	1939-71
0 254 155	65179	Turbocharger Information 1	TCI1	No	1939-71
0 254 156	65180	Main Bearing Temperature 3	MBT3	No	1939-71
0 254 157	65181	Main Bearing Temperature 2	MBT2	No	1939-71
0 254 158	65182	Main Bearing Temperature 1	MBT1	No	1939-71
0 254 159	65183	Exhaust Port Temperature 5	EPT5	No	1939-71
0 254 160	65184	Exhaust Port Temperature 4	EPT4	No	1939-71
0 254 161	65185	Exhaust Port Temperature 3	EPT3	No	1939-71
0 254 162	65186	Exhaust Port Temperature 2	EPT2	No	1939-71
0 254 163	65187	Exhaust Port Temperature 1	EPT1	No	1939-71
0 254 164	65188	Engine Temperature 2	ET2	No	1939-71
0 254 165	65189	Intake Manifold Information 2	IMT2	No	1939-71
0 254 166	65190	Intake Manifold Information 1	IMT1	No	1939-71
0 254 167	65191	Alternator Temperature	AT	No	1939-71
0 254 168	65192	Articulation Control	AC	No	1939-71
0 254 169	65193	Exhaust Oxygen 1	EO1	No	1939-71
0 254 170	65194	Alternate Fuel 2	AF2	No	1939-71
0 254 171	65195	Electronic Transmission Controller 6	ETC6	No	1939-71
0 254 172	65196	Wheel Brake Lining Remaining Information	EBC4	No	1939-71
0 254 173	65197	Wheel Application Pressure High Range Information	EBC3	No	1939-71

0 254 174	65198	Air Supply Pressure	AIR1	No	1939-71
0 254 175	65199	Fuel Consumption (Gaseous)	GFC	No	1939-71
0 254 176	65200	Trip Time Information 2	TTI2	No	1939-71
0 254 177	65201	ECU History	EH	No	1939-71
0 254 178	65202	Fuel Information 1 (Gaseous)	GFI1	No	1939-71
0 254 179	65203	Fuel Information (Liquid)	LFI	No	1939-71
0 254 180	65204	Trip Time Information 1	TTI1	No	1939-71
0 254 181	65205	Trip Shutdown Information	TSI	No	1939-71
0 254 182	65206	Trip Vehicle Speed/Cruise Distance Information	TVI	No	1939-71
0 254 183	65207	Engine Speed/Load Factor Information	LF	No	1939-71
0 254 184	65208	Trip Fuel Information (Gaseous)	GTFI	No	1939-71
0 254 185	65209	Trip Fuel Information (Liquid)	LTFI	No	1939-71
0 254 186	65210	Trip Distance Information	TDI	No	1939-71
0 254 187	65211	Trip Fan Information	TFI	No	1939-71
0 254 188	65212	Compression/Service Brake Information	CBI	No	1939-71
0 254 189	65213	Fan Drive	FD	No	1939-71
0 254 190	65214	Electronic Engine Controller 4	EEC4	No	1939-71
0 254 191	65215	Wheel Speed Information	EBC2	No	1939-71
0 254 192	65216	Service Information	SERV	Yes	1939-71
0 254 193	65217	High-Resolution Vehicle Distance	VDHR	No	1939-71
0 254 194	65218	Electronic Retarder Controller 2	ERC2	No	1939-71
0 254 195	65219	Electronic Transmission Controller 5	ETC5	No	1939-71
0 254 196	65220	ISO 11992	EBS22	No	ISO 11992
0 254 197	65221	Electronic Transmission Controller 4	ETC4	No	1939-71
0 254 198	65222	ISO 11992	EBS23	No	ISO 11992

Parameter group that transfers status and measured information on the engine coolant fan

0 254 199	65223	Electronic Transmission Controller 3	ETC3	No	1939-71
0 254 200	65224	ISO 11992	GFM24	No	ISO 11992
0 254 201	65225	ISO 11992	EBS12	No	ISO 11992
0 254 202	65226	Diagnostic Message #1 Active Diagnostic Trouble Codes	DM1	Yes	1939-73
0 254 203	65227	Diagnostic Message #2	DM2	Yes	1939-73
0 254 204	65228	Diagnostic Message #3	DM3	No	1939-73
0 254 205	65229	Diagnostic Message #4	DM4	Yes	1939-73
0 254 206	65230	Diagnostic Message #5	DM5	Yes	1939-73
0 254 207	65231	Diagnostic Message #6	DM6	Yes	1939-73
0 254 208	65232	Diagnostic Message #8	DM8	Yes	1939-73
0 254 209	65233	Oxygen Sensor Test Results	DM9	No	1939-73
0 254 210	65234	Diagnostic Message #10	DM10	No	1939-73
0 254 211	65235	Diagnostic Message #11	DM11	No	1939-73
0 254 212	65236	Diagnostic Message #12	DM12	Yes	1939-73
0 254 213	65237	Alternator Speed	AS	No	1939-71
0 254 214	65238	Reserved for Network Management	RESV1	No	ISO 11783-5
0 254 215	65239	Reserved	RESV2	No	ISO 11783-5
0 254 216	65240	Commanded Address	CA	Yes	ISO 11783-5
0 254 217	65241	Auxiliary Input/Output Status	AUXIO	No	1939-71
0 254 218	65242	Software Identification	SOFT	Yes	1939-71
0 254 219	65243	Engine Fluid Level/Pressure 2	EFL/P2	No	1939-71
0 254 220	65244	Idle Operation	IO	Yes	1939-71
0 254 221	65245	Turbocharger	TC	No	1939-71
0 254 222	65246	Air Start Pressure	AIR2	No	1939-71
0 254 223	65247	Electronic Engine Controller 3	EEC3	No	1939-71

0 254 224	65248	Vehicle Distance	VD	No	1939-71	
0 254 225	65249	Retarder Configuration	RC	Yes	1939-71	
0 254 226	65250	Transmission Configuration	TCFG	Yes	1939-71	Total message length depends on total number of forward and reverse gear ratios.
0 254 227	65251	Engine Configuration	EC	Yes	1939-71	Engine configuration information
0 254 228	65252	Shutdown	SHUTDOWN	No	1939-71	
0 254 229	65253	Engine Hours, Revolutions	HOURS	No	1939-71	
0 254 230	65254	Time/Date	TD	No	1939-71	
0 254 231	65255	Vehicle Hours	VH	No	1939-71	
0 254 232	65256	Vehicle Direction/Speed	VDS	No	1939-71	
0 254 233	65257	Fuel Consumption (Liquid)	LFC	No	1939-71	
0 254 234	65258	Vehicle Weight	VW	No	1939-71	
0 254 235	65259	Component Identification	CI	Yes	1939-71	
0 254 236	65260	Vehicle Identification	VI	Yes	1939-71	
0 254 237	65261	Cruise Control/Vehicle Speed Setup	CCSS	No	1939-71	
0 254 238	65262	Engine Temperature 1	ET1	No	1939-71	
0 254 239	65263	Engine Fluid Level/Pressure 1	EFL/P1	No	1939-71	
0 254 240	65264	Power Take-off Information	PTO	No	1939-71	
0 254 241	65265	Cruise Control/Vehicle Speed	CCVS	No	1939-71	
0 254 242	65266	Fuel Economy (Liquid)	LFE	No	1939-71	
0 254 243	65267	Vehicle Position	VP	No	1939-71	
0 254 244	65268	Tyre Condition	TYRE	No	1939-71	Tyre condition message
0 254 245	65269	Ambient Conditions	AMB	No	1939-71	
0 254 246	65270	Inlet/Exhaust Conditions 1	IC1	No	1939-71	
0 254 247	65271	Vehicle Electrical Power	VEP	No	1939-71	
0 254 248	65272	Transmission Fluids	TF	No	1939-71	

0 254 249	65273	Axle Information	AI	No	1939-71	Axle information message
0 254 250	65274	Brakes	B	No	1939-71	
0 254 251	65275	Retarder Fluids	RF	No	1939-71	
0 254 252	65276	Dash Display	DD	No	1939-71	
0 254 253	65277	Alternate Fuel 1	A1	No	1939-71	
0 254 254	65278	Auxiliary Water Pump Pressure	AWPP	No	1939-71	
0 254 255	65279	Water in Fuel Indicator	WFI	No	1939-71	
0 255 0	65280	Proprietary B	PropB_00	Yes	ISO 11783-3	
0 255 1	65281	Proprietary B	PropB_01	Yes	ISO 11783-3	
0 255 2	65282	Proprietary B	PropB_02	Yes	ISO 11783-3	
0 255 3	65283	Proprietary B	PropB_03	Yes	ISO 11783-3	
0 255 4	65284	Proprietary B	PropB_04	Yes	ISO 11783-3	
0 255 5	65285	Proprietary B	PropB_05	Yes	ISO 11783-3	
0 255 6	65286	Proprietary B	PropB_06	Yes	ISO 11783-3	
0 255 7	65287	Proprietary B	PropB_07	Yes	ISO 11783-3	
0 255 8	65288	Proprietary B	PropB_08	Yes	ISO 11783-3	
0 255 9	65289	Proprietary B	PropB_09	Yes	ISO 11783-3	
0 255 10	65290	Proprietary B	PropB_0A	Yes	ISO 11783-3	
0 255 11	65291	Proprietary B	PropB_0B	Yes	ISO 11783-3	
0 255 12	65292	Proprietary B	PropB_0C	Yes	ISO 11783-3	
0 255 13	65293	Proprietary B	PropB_0D	Yes	ISO 11783-3	
0 255 14	65294	Proprietary B	PropB_0E	Yes	ISO 11783-3	
0 255 15	65295	Proprietary B	PropB_0F	Yes	ISO 11783-3	
0 255 16	65296	Proprietary B	PropB_10	Yes	ISO 11783-3	
0 255 17	65297	Proprietary B	PropB_11	Yes	ISO 11783-3	
0 255 18	65298	Proprietary B	PropB_12	Yes	ISO 11783-3	

0 255 19	65299	Proprietary B	PropB_13	Yes	ISO 11783-3
0 255 20	65300	Proprietary B	PropB_14	Yes	ISO 11783-3
0 255 21	65301	Proprietary B	PropB_15	Yes	ISO 11783-3
0 255 22	65302	Proprietary B	PropB_16	Yes	ISO 11783-3
0 255 23	65303	Proprietary B	PropB_17	Yes	ISO 11783-3
0 255 24	65304	Proprietary B	PropB_18	Yes	ISO 11783-3
0 255 25	65305	Proprietary B	PropB_19	Yes	ISO 11783-3
0 255 26	65306	Proprietary B	PropB_1A	Yes	ISO 11783-3
0 255 27	65307	Proprietary B	PropB_1B	Yes	ISO 11783-3
0 255 28	65308	Proprietary B	PropB_1C	Yes	ISO 11783-3
0 255 29	65309	Proprietary B	PropB_1D	Yes	ISO 11783-3
0 255 30	65310	Proprietary B	PropB_1E	Yes	ISO 11783-3
0 255 31	65311	Proprietary B	PropB_1F	Yes	ISO 11783-3
0 255 32	65312	Proprietary B	PropB_20	Yes	ISO 11783-3
0 255 33	65313	Proprietary B	PropB_21	Yes	ISO 11783-3
0 255 34	65314	Proprietary B	PropB_22	Yes	ISO 11783-3
0 255 35	65315	Proprietary B	PropB_23	Yes	ISO 11783-3
0 255 36	65316	Proprietary B	PropB_24	Yes	ISO 11783-3
0 255 37	65317	Proprietary B	PropB_25	Yes	ISO 11783-3
0 255 38	65318	Proprietary B	PropB_26	Yes	ISO 11783-3
0 255 39	65319	Proprietary B	PropB_27	Yes	ISO 11783-3
0 255 40	65320	Proprietary B	PropB_28	Yes	ISO 11783-3
0 255 41	65321	Proprietary B	PropB_29	Yes	ISO 11783-3
0 255 42	65322	Proprietary B	PropB_2A	Yes	ISO 11783-3
0 255 43	65323	Proprietary B	PropB_2B	Yes	ISO 11783-3
0 255 44	65324	Proprietary B	PropB_2C	Yes	ISO 11783-3



0 255 45	65325	Proprietary B	PropB_2D	Yes	ISO 11783-3
0 255 46	65326	Proprietary B	PropB_2E	Yes	ISO 11783-3
0 255 47	65327	Proprietary B	PropB_2F	Yes	ISO 11783-3
0 255 48	65328	Proprietary B	PropB_30	Yes	ISO 11783-3
0 255 49	65329	Proprietary B	PropB_31	Yes	ISO 11783-3
0 255 50	65330	Proprietary B	PropB_32	Yes	ISO 11783-3
0 255 51	65331	Proprietary B	PropB_33	Yes	ISO 11783-3
0 255 52	65332	Proprietary B	PropB_34	Yes	ISO 11783-3
0 255 53	65333	Proprietary B	PropB_35	Yes	ISO 11783-3
0 255 54	65334	Proprietary B	PropB_36	Yes	ISO 11783-3
0 255 55	65335	Proprietary B	PropB_37	Yes	ISO 11783-3
0 255 56	65336	Proprietary B	PropB_38	Yes	ISO 11783-3
0 255 57	65337	Proprietary B	PropB_39	Yes	ISO 11783-3
0 255 58	65338	Proprietary B	PropB_3A	Yes	ISO 11783-3
0 255 59	65339	Proprietary B	PropB_3B	Yes	ISO 11783-3
0 255 60	65340	Proprietary B	PropB_3C	Yes	ISO 11783-3
0 255 61	65341	Proprietary B	PropB_3D	Yes	ISO 11783-3
0 255 62	65342	Proprietary B	PropB_3E	Yes	ISO 11783-3
0 255 63	65343	Proprietary B	PropB_3F	Yes	ISO 11783-3
0 255 64	65344	Proprietary B	PropB_40	Yes	ISO 11783-3
0 255 65	65345	Proprietary B	PropB_41	Yes	ISO 11783-3
0 255 66	65346	Proprietary B	PropB_42	Yes	ISO 11783-3
0 255 67	65347	Proprietary B	PropB_43	Yes	ISO 11783-3
0 255 68	65348	Proprietary B	PropB_44	Yes	ISO 11783-3
0 255 69	65349	Proprietary B	PropB_45	Yes	ISO 11783-3
0 255 70	65350	Proprietary B	PropB_46	Yes	ISO 11783-3

0	255 71	65351	Proprietary B	PropB_47	Yes	ISO 11783-3
0	255 72	65352	Proprietary B	PropB_48	Yes	ISO 11783-3
0	255 73	65353	Proprietary B	PropB_49	Yes	ISO 11783-3
0	255 74	65354	Proprietary B	PropB_4A	Yes	ISO 11783-3
0	255 75	65355	Proprietary B	PropB_4B	Yes	ISO 11783-3
0	255 76	65356	Proprietary B	PropB_4C	Yes	ISO 11783-3
0	255 77	65357	Proprietary B	PropB_4D	Yes	ISO 11783-3
0	255 78	65358	Proprietary B	PropB_4E	Yes	ISO 11783-3
0	255 79	65359	Proprietary B	PropB_4F	Yes	ISO 11783-3
0	255 80	65360	Proprietary B	PropB_50	Yes	ISO 11783-3
0	255 81	65361	Proprietary B	PropB_51	Yes	ISO 11783-3
0	255 82	65362	Proprietary B	PropB_52	Yes	ISO 11783-3
0	255 83	65363	Proprietary B	PropB_53	Yes	ISO 11783-3
0	255 84	65364	Proprietary B	PropB_54	Yes	ISO 11783-3
0	255 85	65365	Proprietary B	PropB_55	Yes	ISO 11783-3
0	255 86	65366	Proprietary B	PropB_56	Yes	ISO 11783-3
0	255 87	65367	Proprietary B	PropB_57	Yes	ISO 11783-3
0	255 88	65368	Proprietary B	PropB_58	Yes	ISO 11783-3
0	255 89	65369	Proprietary B	PropB_59	Yes	ISO 11783-3
0	255 90	65370	Proprietary B	PropB_5A	Yes	ISO 11783-3
0	255 91	65371	Proprietary B	PropB_5B	Yes	ISO 11783-3
0	255 92	65372	Proprietary B	PropB_5C	Yes	ISO 11783-3
0	255 93	65373	Proprietary B	PropB_5D	Yes	ISO 11783-3
0	255 94	65374	Proprietary B	PropB_5E	Yes	ISO 11783-3
0	255 95	65375	Proprietary B	PropB_5F	Yes	ISO 11783-3
0	255 96	65376	Proprietary B	PropB_60	Yes	ISO 11783-3

0 255 97	65377	Proprietary B	PropB_61	Yes	ISO 11783-3
0 255 99	65379	Proprietary B	PropB_63	Yes	ISO 11783-3
0 255 100	65380	Proprietary B	PropB_64	Yes	ISO 11783-3
0 255 101	65381	Proprietary B	PropB_65	Yes	ISO 11783-3
0 255 102	65382	Proprietary B	PropB_66	Yes	ISO 11783-3
0 255 103	65383	Proprietary B	PropB_67	Yes	ISO 11783-3
0 255 104	65384	Proprietary B	PropB_68	Yes	ISO 11783-3
0 255 105	65385	Proprietary B	PropB_69	Yes	ISO 11783-3
0 255 106	65386	Proprietary B	PropB_6A	Yes	ISO 11783-3
0 255 107	65387	Proprietary B	PropB_6B	Yes	ISO 11783-3
0 255 108	65388	Proprietary B	PropB_6C	Yes	ISO 11783-3
0 255 109	65389	Proprietary B	PropB_6D	Yes	ISO 11783-3
0 255 110	65390	Proprietary B	PropB_6E	Yes	ISO 11783-3
0 255 111	65391	Proprietary B	PropB_6F	Yes	ISO 11783-3
0 255 112	65392	Proprietary B	PropB_70	Yes	ISO 11783-3
0 255 113	65393	Proprietary B	PropB_71	Yes	ISO 11783-3
0 255 114	65394	Proprietary B	PropB_72	Yes	ISO 11783-3
0 255 115	65395	Proprietary B	PropB_73	Yes	ISO 11783-3
0 255 116	65396	Proprietary B	PropB_74	Yes	ISO 11783-3
0 255 117	65397	Proprietary B	PropB_75	Yes	ISO 11783-3
0 255 118	65398	Proprietary B	PropB_76	Yes	ISO 11783-3
0 255 119	65399	Proprietary B	PropB_77	Yes	ISO 11783-3
0 255 120	65400	Proprietary B	PropB_78	Yes	ISO 11783-3
0 255 121	65401	Proprietary B	PropB_79	Yes	ISO 11783-3
0 255 122	65402	Proprietary B	PropB_7A	Yes	ISO 11783-3
0 255 123	65403	Proprietary B	PropB_7B	Yes	ISO 11783-3

0 255 124	65404	Proprietary B	PropB_7C	Yes	ISO 11783-3
0 255 125	65405	Proprietary B	PropB_7D	Yes	ISO 11783-3
0 255 126	65406	Proprietary B	PropB_7E	Yes	ISO 11783-3
0 255 127	65407	Proprietary B	PropB_7F	Yes	ISO 11783-3
0 255 128	65408	Proprietary B	PropB_80	Yes	ISO 11783-3
0 255 129	65409	Proprietary B	PropB_81	Yes	ISO 11783-3
0 255 130	65410	Proprietary B	PropB_82	Yes	ISO 11783-3
0 255 131	65411	Proprietary B	PropB_83	Yes	ISO 11783-3
0 255 132	65412	Proprietary B	PropB_84	Yes	ISO 11783-3
0 255 133	65413	Proprietary B	PropB_85	Yes	ISO 11783-3
0 255 134	65414	Proprietary B	PropB_86	Yes	ISO 11783-3
0 255 135	65415	Proprietary B	PropB_87	Yes	ISO 11783-3
0 255 136	65416	Proprietary B	PropB_88	Yes	ISO 11783-3
0 255 137	65417	Proprietary B	PropB_89	Yes	ISO 11783-3
0 255 138	65418	Proprietary B	PropB_8A	Yes	ISO 11783-3
0 255 139	65419	Proprietary B	PropB_8B	Yes	ISO 11783-3
0 255 140	65420	Proprietary B	PropB_8C	Yes	ISO 11783-3
0 255 141	65421	Proprietary B	PropB_8D	Yes	ISO 11783-3
0 255 142	65422	Proprietary B	PropB_8E	Yes	ISO 11783-3
0 255 143	65423	Proprietary B	PropB_8F	Yes	ISO 11783-3
0 255 144	65424	Proprietary B	PropB_90	Yes	ISO 11783-3
0 255 145	65425	Proprietary B	PropB_91	Yes	ISO 11783-3
0 255 146	65426	Proprietary B	PropB_92	Yes	ISO 11783-3
0 255 147	65427	Proprietary B	PropB_93	Yes	ISO 11783-3
0 255 148	65428	Proprietary B	PropB_94	Yes	ISO 11783-3
0 255 149	65429	Proprietary B	PropB_95	Yes	ISO 11783-3

0	255 150	65430	Proprietary B	PropB_96	Yes	ISO 11783-3
0	255 151	65431	Proprietary B	PropB_97	Yes	ISO 11783-3
0	255 152	65432	Proprietary B	PropB_98	Yes	ISO 11783-3
0	255 153	65433	Proprietary B	PropB_99	Yes	ISO 11783-3
0	255 154	65434	Proprietary B	PropB_9A	Yes	ISO 11783-3
0	255 155	65435	Proprietary B	PropB_9B	Yes	ISO 11783-3
0	255 156	65436	Proprietary B	PropB_9C	Yes	ISO 11783-3
0	255 157	65437	Proprietary B	PropB_9D	Yes	ISO 11783-3
0	255 158	65438	Proprietary B	PropB_9E	Yes	ISO 11783-3
0	255 159	65439	Proprietary B	PropB_9F	Yes	ISO 11783-3
0	255 160	65440	Proprietary B	PropB_A0	Yes	ISO 11783-3
0	255 161	65441	Proprietary B	PropB_A1	Yes	ISO 11783-3
0	255 162	65442	Proprietary B	PropB_A2	Yes	ISO 11783-3
0	255 163	65443	Proprietary B	PropB_A3	Yes	ISO 11783-3
0	255 164	65444	Proprietary B	PropB_A4	Yes	ISO 11783-3
0	255 165	65445	Proprietary B	PropB_A5	Yes	ISO 11783-3
0	255 166	65446	Proprietary B	PropB_A6	Yes	ISO 11783-3
0	255 167	65447	Proprietary B	PropB_A7	Yes	ISO 11783-3
0	255 168	65448	Proprietary B	PropB_A8	Yes	ISO 11783-3
0	255 169	65449	Proprietary B	PropB_A9	Yes	ISO 11783-3
0	255 170	65450	Proprietary B	PropB_AA	Yes	ISO 11783-3
0	255 171	65451	Proprietary B	PropB_AB	Yes	ISO 11783-3
0	255 172	65452	Proprietary B	PropB_AC	Yes	ISO 11783-3
0	255 173	65453	Proprietary B	PropB_AD	Yes	ISO 11783-3
0	255 174	65454	Proprietary B	PropB_AE	Yes	ISO 11783-3
0	255 175	65455	Proprietary B	PropB_AF	Yes	ISO 11783-3

0	255 176	65456	Proprietary B	PropB_B0	Yes	ISO 11783-3
0	255 177	65457	Proprietary B	PropB_B1	Yes	ISO 11783-3
0	255 178	65458	Proprietary B	PropB_B2	Yes	ISO 11783-3
0	255 179	65459	Proprietary B	PropB_B3	Yes	ISO 11783-3
0	255 180	65460	Proprietary B	PropB_B4	Yes	ISO 11783-3
0	255 181	65461	Proprietary B	PropB_B5	Yes	ISO 11783-3
0	255 182	65462	Proprietary B	PropB_B6	Yes	ISO 11783-3
0	255 183	65463	Proprietary B	PropB_B7	Yes	ISO 11783-3
0	255 184	65464	Proprietary B	PropB_B8	Yes	ISO 11783-3
0	255 185	65465	Proprietary B	PropB_B9	Yes	ISO 11783-3
0	255 186	65466	Proprietary B	PropB_BA	Yes	ISO 11783-3
0	255 187	65467	Proprietary B	PropB_BB	Yes	ISO 11783-3
0	255 188	65468	Proprietary B	PropB_BC	Yes	ISO 11783-3
0	255 189	65469	Proprietary B	PropB_BD	Yes	ISO 11783-3
0	255 190	65470	Proprietary B	PropB_BE	Yes	ISO 11783-3
0	255 191	65471	Proprietary B	PropB_BF	Yes	ISO 11783-3
0	255 192	65472	Proprietary B	PropB_C0	Yes	ISO 11783-3
0	255 193	65473	Proprietary B	PropB_C1	Yes	ISO 11783-3
0	255 194	65474	Proprietary B	PropB_C2	Yes	ISO 11783-3
0	255 195	65475	Proprietary B	PropB_C3	Yes	ISO 11783-3
0	255 196	65476	Proprietary B	PropB_C4	Yes	ISO 11783-3
0	255 197	65477	Proprietary B	PropB_C5	Yes	ISO 11783-3
0	255 198	65478	Proprietary B	PropB_C6	Yes	ISO 11783-3
0	255 199	65479	Proprietary B	PropB_C7	Yes	ISO 11783-3
0	255 200	65480	Proprietary B	PropB_C8	Yes	ISO 11783-3
0	255 201	65481	Proprietary B	PropB_C9	Yes	ISO 11783-3

0 255 202	65482	Proprietary B	PropB_CA	Yes	ISO 11783-3
0 255 203	65483	Proprietary B	PropB_CB	Yes	ISO 11783-3
0 255 204	65484	Proprietary B	PropB_CC	Yes	ISO 11783-3
0 255 205	65485	Proprietary B	PropB_CD	Yes	ISO 11783-3
0 255 206	65486	Proprietary B	PropB_CE	Yes	ISO 11783-3
0 255 207	65487	Proprietary B	PropB_CF	Yes	ISO 11783-3
0 255 208	65488	Proprietary B	PropB_D0	Yes	ISO 11783-3
0 255 209	65489	Proprietary B	PropB_D1	Yes	ISO 11783-3
0 255 210	65490	Proprietary B	PropB_D2	Yes	ISO 11783-3
0 255 211	65491	Proprietary B	PropB_D3	Yes	ISO 11783-3
0 255 212	65492	Proprietary B	PropB_D4	Yes	ISO 11783-3
0 255 213	65493	Proprietary B	PropB_D5	Yes	ISO 11783-3
0 255 214	65494	Proprietary B	PropB_D6	Yes	ISO 11783-3
0 255 215	65495	Proprietary B	PropB_D7	Yes	ISO 11783-3
0 255 216	65496	Proprietary B	PropB_D8	Yes	ISO 11783-3
0 255 217	65497	Proprietary B	PropB_D9	Yes	ISO 11783-3
0 255 218	65498	Proprietary B	PropB_DA	Yes	ISO 11783-3
0 255 219	65499	Proprietary B	PropB_DB	Yes	ISO 11783-3
0 255 220	65500	Proprietary B	PropB_DC	Yes	ISO 11783-3
0 255 221	65501	Proprietary B	PropB_DD	Yes	ISO 11783-3
0 255 222	65502	Proprietary B	PropB_DE	Yes	ISO 11783-3
0 255 223	65503	Proprietary B	PropB_DF	Yes	ISO 11783-3
0 255 224	65504	Proprietary B	PropB_E0	Yes	ISO 11783-3
0 255 225	65505	Proprietary B	PropB_E1	Yes	ISO 11783-3
0 255 226	65506	Proprietary B	PropB_E2	Yes	ISO 11783-3
0 255 227	65507	Proprietary B	PropB_E3	Yes	ISO 11783-3

0	255 228	65508	Proprietary B	PropB_E4	Yes	ISO 11783-3
0	255 229	65509	Proprietary B	PropB_E5	Yes	ISO 11783-3
0	255 230	65510	Proprietary B	PropB_E6	Yes	ISO 11783-3
0	255 231	65511	Proprietary B	PropB_E7	Yes	ISO 11783-3
0	255 232	65512	Proprietary B	PropB_E8	Yes	ISO 11783-3
0	255 233	65513	Proprietary B	PropB_E9	Yes	ISO 11783-3
0	255 234	65514	Proprietary B	PropB_EA	Yes	ISO 11783-3
0	255 235	65515	Proprietary B	PropB_EB	Yes	ISO 11783-3
0	255 236	65516	Proprietary B	PropB_EC	Yes	ISO 11783-3
0	255 237	65517	Proprietary B	PropB_ED	Yes	ISO 11783-3
0	255 238	65518	Proprietary B	PropB_EE	Yes	ISO 11783-3
0	255 239	65519	Proprietary B	PropB_EF	Yes	ISO 11783-3
0	255 240	65520	Proprietary B	PropB_F0	Yes	ISO 11783-3
0	255 241	65521	Proprietary B	PropB_F1	Yes	ISO 11783-3
0	255 242	65522	Proprietary B	PropB_F2	Yes	ISO 11783-3
0	255 243	65523	Proprietary B	PropB_F3	Yes	ISO 11783-3
0	255 244	65524	Proprietary B	PropB_F4	Yes	ISO 11783-3
0	255 245	65525	Proprietary B	PropB_F5	Yes	ISO 11783-3
0	255 246	65526	Proprietary B	PropB_F6	Yes	ISO 11783-3
0	255 247	65527	Proprietary B	PropB_F7	Yes	ISO 11783-3
0	255 248	65528	Proprietary B	PropB_F8	Yes	ISO 11783-3
0	255 249	65529	Proprietary B	PropB_F9	Yes	ISO 11783-3
0	255 250	65530	Proprietary B	PropB_FA	Yes	ISO 11783-3
0	255 251	65531	Proprietary B	PropB_FB	Yes	ISO 11783-3
0	255 252	65532	Proprietary B	PropB_FC	Yes	ISO 11783-3
0	255 253	65533	Proprietary B	PropB_FD	Yes	ISO 11783-3



0	255	254	65534	Proprietary B	PropB_FE	Yes	ISO 11783-3				
0	255	255	65535	Proprietary B	PropB_FF	Yes	ISO 11783-3				
1	237	DA	126208	Request/Command/Acknowledge Group Function		No	IEC 61162-3	Request/Command/Acknowledge Group Type of function is defined by first field			
1	238	DA	126464	PGN List – Transmit/Receive PGN's Group Function		No	ISO 11783-3	Transmit/Receive PGN List Group Type of function is defined by first field			
1	239	DA	126720	Proprietary A2	PropA2	No	ISO 11783-3	Destination-specific PDU format proprietary PG allowing manufacturers to direct their proprietary communications to a specific destination node			
1	240	16	126992	System Time		No	IEC 61162-3	PGN providing a regular transmission of UTC time and date			
1	240	20	126996	Product Information		No	IEC 61162-3	Provides product information on the network that could be important for determining quality of data coming from this product			
1	240	22	126998	Configuration Information		No	IEC 61162-3	Free-form alphanumeric fields describing the installation (e.g., starboard engine room location) of the unit			
1	241	5	127237	Heading/Track Control		No	IEC 61162-3	Sends commands to, and receives data from, heading control systems			
1	241	13	127245	Rudder		No	IEC 61162-3	Rudder order command in direction or angle with current rudder angle reading			
1	241	18	127250	Vessel Heading		No	IEC 61162-3	Heading sensor value with a flag for true or magnetic			
1	241	19	127251	Rate of Turn		No	IEC 61162-3	Rate of Turn PGN added in version 1,004 of this standard			
1	241	25	127257	Attitude		No	IEC 61162-3	PGN providing a single transmission that describes the position of a vessel relative to both horizontal and vertical planes			
1	242	0	127488	Engine Parameters, Rapid Update		No	IEC 61162-3	Provides data with a high update rate for a specific engine in a single frame message			
1	242	1	127489	Engine Parameters, Dynamic		No	IEC 61162-3	Provides real-time operational data and status relevant to a specific engine, indicated by the engine instance field			

1	242	5	127493	Transmission Parameters, Dynamic	No	IEC 61162-3	Provides the operational state and internal operating parameters of a specific transmission
1	242	9	127497	Trip Parameters	No	IEC 61162-3	Small craft trip engine hours and fuel consumption
1	242	10	127498	Engine Parameters, Static	No	IEC 61162-3	Provides identification information and rated engine speed for the engine indicated by the engine instance field
1	242	13	127501	Binary Switch Bank Status	No	IEC 61162-3	Universal status report for multiple banks of two-state indicators
1	242	14	127502	Switch Bank Control	No	IEC 61162-3	Universal commands to multiple banks of two-state controls
1	242	17	127505	Fluid Level	No	IEC 61162-3	Contains an instance number, level of fluid and type of fluid
1	242	20	127508	Battery Status	No	IEC 61162-3	Provides parametric data for a specific battery, indicated by the battery instance field
1	245	3	128259	Speed	No	IEC 61162-3	PGN to provide a single transmission that describes the motion of a vessel
1	245	11	128267	Water Depth	No	IEC 61162-3	Water depth relative to the transducer and offset of the measuring transducer
1	245	19	128275	Distance Log	No	IEC 61162-3	PGN to provide the cumulative voyage distance travelled since the last reset
1	246	8	128520	Tracked Target	No	IEC 61162-3	Data Message for reporting status and target data from tracking radar external units
1	248	1	129025	Position, Rapid Update	No	IEC 61162-3	PGN to provide latitude and longitude referenced to WGS-84
1	248	2	129026	COG & SOG, Rapid Update	No	IEC 61162-3	Single-frame PGN that provides course over ground (COG) and speed over ground (SOG)
1	248	5	129029	GNSS Position Data	No	IEC 61162-3	PGN conveying a comprehensive set of global navigation satellite system (GNSS) parameters, including position information
1	248	9	129033	Time & Date	No	IEC 61162-3	Single transmission PGN that provides UTC Time, UTC Date and local offset
1	248	20	129044	Datum	No	IEC 61162-3	Local geodetic datum and datum offsets from a reference datum
1	248	21	129045	User Datum Settings	No	IEC 61162-3	Transformation parameters for converting from WGS-84 to other datums
1	249	3	129283	Cross Track Error	No	IEC 61162-3	PGN providing the magnitude of position error perpendicular to the desired course

1	249	4	129284	Navigation Data	No	IEC 61162-3	PGN providing essential navigation data for a route following
1	249	11	129291	Set & Drift, Rapid Update	No	IEC 61162-3	Set and drift effect on the vessel is the direction and the speed of a current
1	249	21	129301	Time to/from Mark	No	IEC 61162-3	Time to go to or elapsed from a generic mark, that can be non-fixed
1	249	22	129302	Bearing and Distance between two Marks	No	IEC 61162-3	Bearing and distance from the origin mark to the destination mark, calculated at the origin mark, for any two arbitrary generic marks
1	250	2	129538	GNSS Control Status	No	IEC 61162-3	GNSS common satellite receiver parameter status
1	250	3	129539	GNSS DOPs	No	IEC 61162-3	PGN to provide a single transmission containing GNSS status and dilution of precision components (DOP)
1	250	4	129540	GNSS Sats in View	No	IEC 61162-3	GNSS information on current satellites in view tagged by sequence ID — information includes PRN, elevation, azimuth and SNR
1	250	5	129541	GPS Almanac Data	No	IEC 61162-3	PGN to provide a single transmission that contains relevant almanac data for GPS products
1	250	6	129542	GNSS Pseudo Range Noise Statistics	No	IEC 61162-3	GNSS pseudo-range measurement noise statistics can be translated in the position domain
1	250	9	129545	GNSS RAIM Output	No	IEC 61162-3	PGN used providing the output from a GNSS receiver's receiver autonomous integrity monitoring (RAIM) process
1	250	10	129546	GNSS RAIM Settings	No	IEC 61162-3	PGN used to report the control parameters for a GNSS RAIM process
1	250	11	129547	GNSS Pseudo Range Error Statistics	No	IEC 61162-3	APGN used to support RAIM
1	250	13	129549	DGNSS Corrections	No	IEC 61162-3	PGN providing a means to pass differential GNSS corrections between IEC 61162-3 units
1	250	14	129550	GNSS Differential Correction Receiver Interface	No	IEC 61162-3	GNSS common differential correction receiver parameter status
1	250	15	129551	GNSS Differential Correction Receiver Signal	No	IEC 61162-3	GNSS differential correction receiver status tagged by sequence ID
1	250	20	129556	GLONASS Almanac Data	No	IEC 61162-3	PGN providing a single transmission that contains relevant almanac data for GNSS products
1	251	7	129799	Radio Frequency/Mode/Power	No	IEC 61162-3	PGN providing status and control for a radiotelephone, connected to a IEC 61162-3 network

1	251	16	129808	DSC Call Information	No	IEC 61162-3	PGN providing digital selective calling (DSC) data according to ITU M.493-9 with optional expansion according to ITU M.821-1
1	252	4	130052	Loran-C TD Data	No	IEC 61162-3	PGN providing time difference (TD) lines of position of Loran-C signals relative to a single group repetition interval
1	252	5	130053	Loran-C Range Data	No	IEC 61162-3	PGN providing propagation times (Ranges) of Loran-C signals relative to a single group repetition interval
1	253	2	130306	Wind Data	No	IEC 61162-3	Direction and speed of wind
1	253	6	130054	Loran-C Signal Data	No	IEC 61162-3	SNR, ECD and ASF values of Loran-C signals
1	253	6	130310	Environmental Parameters	No	IEC 61162-3	Local atmospheric environmental conditions
1	253	16	130320	Tide Station Data	No	IEC 61162-3	Tide station measurement data including station location, numeric identifier and name
1	253	17	130321	Salinity Station Data	No	IEC 61162-3	Salinity station measurement data including station location, numeric identifier and name
1	253	18	130322	Current Station Data	No	IEC 61162-3	Current station measurement data including station location, numeric identifier and name
1	253	19	130323	Meteorological Station Data	No	IEC 61162-3	Meteorological station measurement data including station location, numeric identifier and name
1	253	20	130324	Moored Buoy Station Data	No	IEC 61162-3	Moored buoy measurement data including station location and numeric identifier
1	254	16	130576	Small Craft Status	No	IEC 61162-3	Provides data on various small craft control surfaces and speed through the water
1	254	7	130577	Direction Data	No	IEC 61162-3	PGN to group three fundamental vectors related to vessel motion
1	254	18	130578	Vessel Speed Components	No	IEC 61162-3	PGN providing a single transmission that accurately describes the speed of a vessel by component vectors

**Annex B**  
(normative)  
**ISO 11783 Industry groups**

Industry Group	Industry
0	Global, applies to all industries
1	On-highway equipment
2	Agricultural and forestry equipment
3	Construction equipment
4	Marine
5	Industrial/process control/stationary
6	Reserved for future assignment
7	Reserved for future assignment

**Annex C**  
(normative)  
**ISO 11783 Industry group 0 preferred addresses**

SA	Function	Instance	ECU instance	Definition
0	Engine	0	0	First instance of a controller for the system's primary source of power
1	Engine	1	0	Second instance of a controller for the system's primary source of power
2	Turbo charger	0	0	
3	Transmission	0	0	First instance of a controller for the system's transmission
4	Transmission	1	0	Second instance of a controller for the system's transmission
5	Shift Console – Primary	0	0	
6	Shift Console – Secondary	1	0	
7	Power Take-Off – Rear or Primary	0	0	First instance of a controller for a power take-off
8	Axle – Steering	0	0	
9	Axle – Drive	0	0	
10	Axle – Drive	1	0	Second instance of a controller for the system's drive axle
11	Brakes – System Control	0	0	
12	Brakes – Steer Axle Control	0	0	
13	Brakes – Drive axle Control	0	0	
14	Brakes – Drive Axle Control	1	0	Second instance of a controller for the system's drive axle brakes
15	Retarder – Engine	0	0	Engine compression braking
16	Retarder – Driveline	0	0	

17	Cruise Control	0	0	0	Speed-based control
18	Fuel System	0	0	0	
19	Steering Control	0	0	0	
20	Suspension Control – Steer Axle	0	0	0	
21	Suspension Control – Drive Axle	0	0	0	
22	Suspension Control – Drive Axle	1	1	0	Second instance of a controller for the system's drive axle suspension
23	Instrument Cluster	0	0	0	Primary gauge display for a vehicle
24	Trip Recorder	0	0	0	
25	Climate Control	0	0	0	
26	Alternator/Electrical Charging Control	0	0	0	Vehicle's primary electrical or alternator charging controller — can be two different functions (alternator or electrical) that can share a preferred address
27	Aerodynamic Control	0	0	0	
28	Vehicle Navigation	0	0	0	
29	Vehicle Security	0	0	0	
30	Electrical Control	0	0	0	
31	Starter Control	0	0	0	
32	Tractor – Trailer (NIU)	0	0	0	Tractor mounted bridge (Gateway or Special NIU) leading to trailer(s)
33	Body Control	0	0	0	Controls the body (not the chassis or cab) functions
34	Auxiliary Valve Control	0	0	0	Controller for the tractor mounted auxiliary valves
35	Hitch Control – Rear	0	0	0	Controller for the hitch on the rear of the agriculture tractor
36	Power Take-Off Control – Front or Secondary	1	1	0	Second instance of a controller for a power take-off
37	Off Vehicle Gateway	0	0	0	
38	Virtual Terminal	0	0	0	
39	Management Computer #1	0	0	0	Manages vehicle systems, i.e. power train

40	Cab Display	0	0	0	First instance of a display other than instrument cluster and virtual terminal
41	Exhaust Retarder, Engine #1	0	0	0	First retarder instance on engine instance 1
42	Headway Control System	0	0	0	Forward-looking collision warning, collision avoidance, speed control or speed matching
43	On-board Diagnostic Unit	0	0	0	
44	Retarder, Exhaust, Engine #2	1	0	0	First instance of the exhaust retarder on the second engine or the second instance of exhaust retarder on the first engine
45	Endurance Braking Control	0	0	0	
46	Hydraulic Pump Control	0	0	0	
47	Suspension Control #1	0	0	0	First instance of the suspension controller (i.e. it is single valued)
48	Pneumatic Control	0	0	0	
49	Primary Cab Control	0	0	0	
50	Secondary Cab Control	1	0	0	Second instance of a controller for the system's cab
51	Tyre Pressure Control	0	0	0	
52	Ignition Control #1	0	0	0	First instance of the ignition control on the engine (i.e. it is single valued)
53	Ignition Control #2	1	0	0	First instance of the ignition control system on the second engine or the second instance of the ignition control system on the first engine
54	Seat #1 Control	0	0	0	First seat controller normally associated with the driver seat
55	Operator Controls – Lighting	0	0	0	
56	Rear Axle Steering Control #1	0	0	0	First instance of the rear axle controller system
57	Water Pump Control	0	0	0	



58	Climate Control #2	1	0	Second climate control system, if determined that the passenger climate control system has to be separated from the first control system (as opposed to being the second instance of the first control system). — Reference PA 25 — it is advisable to use the climate control system #1 (PA 25) with instances
59	Transmission #1 Primary Display	0	0	First instance of a display to operate with the primary transmission control
60	Transmission #2 Secondary Display	1	0	Second instance of a display to operate with the primary transmission control
61	Exhaust Emission Control	0	0	
62	Vehicle Dynamic Stability Control	0	0	
63	Oil System Monitor	0	0	
64	Suspension Control #2	0	0	First instance of the second suspension control system (i.e. it is single valued)
65	Information Control #1	0	0	Information management system, for the vehicle's application, such as transit passenger/fare monitoring, truck cargo management
66	Ramp Control	0	0	Controller for ramps, lifts or tailgates
67	Clutch/Converter Control	0	0	Controller of either the clutch and/or hydraulic torque converter
68	Auxiliary Heater Control #1	0	0	Can be air, water or other heater type and be using engine heat, electrical or fuel fired heating source
69	Auxiliary Heater Control #2	1	0	Can be air, water or other heater type and be using engine heat, electrical or fuel fired heating source
70	Engine Valve Control	0	0	Electronic control used to control actuation of engine intake and/or exhaust valves
71	Chassis Control	0	0	ECU for controlling the functions of the first chassis control system other than power train, body and cab functions (i.e. this is the first instance)
72	Chassis Control	1	0	ECU for controlling the functions of the second chassis control system other than power train, body and cab functions (i.e. this is the second instance)

73	Propulsion Battery Charger	0	0	0	A controller used to charge propulsion batteries in an electric vehicle from an off-board source of electrical energy
74	Communications, Cellular	0	0	0	Cellular communications unit
75	Communications, Satellite	0	0	0	Satellite communications unit
76	Communications, Radio	0	0	0	Radio communications unit
77	Operator Controls, Steering Column Unit	0	0	0	Unit that gathers the operator's inputs for the steering column
78	Fan Drive Control System	0	0	0	Controls the main cooling fan operation
79	Seat #2 Control	0	0	1	Second seat control normally associated with the passenger seat
80	Parking Brake Controller	0	0	0	Controller for the parking brake
83-127	Reserved for Future Assignment by ISO				
128-247	Industry Group Specific				
248	File Server or Printer				See Annex D for agricultural and forestry equipment
249	Off Board Diagnostic/Service Tool #1	0	0	0	
250	Off Board Diagnostic/Service Tool #2	1	0	0	
251	On-Board Data Logger	0	0	0	
252	Reserved for Experimental Use	0	0	0	
253	Reserved for OEM	0	0	0	
254	Null Address				
255	GLOBAL				All/any control function

## Annex D (normative)

### ISO 11783 Industry group 2 initial addresses

SA	Device	Instance	Function	Instance	ECU Instance	Definition
128 -238			Reserved for Future Assignment by ISO			All control functions in IG2 using initial addresses shall be self-configurable. IG2 control functions shall include the value of the first full 32 bits of NAME field.
239	0	0	Position Control	0	0	
240	0	0	Tractor ECU	0	0	Gateway between the tractor network and the implement network
241	7	0	Tailings Monitoring	0	0	
242	7	0	Header Control	0	0	
243	7	0	Product Loss Monitoring	0	0	
244	7	0	Product Moisture Sensing	0	0	
245	0	0	Non-Virtual Terminal Display (Implement Network)	0	0	Non-virtual terminal cab display connected to the implement network
246	0	0	Operator Controls – Machine Specific	0	0	
247	0	0	Task Control (Mapping Computer)	0	0	

**Annex E**  
(normative)  
**ISO 11783 NAMES**

Value	Device	Value	Function	Description
<b>0 Global</b>				
0	Non-specific systems			
		0-127	See Annex F	Industry non-specific
		128	Reserved	
		129	On-Board Diagnostic Service Tool	Tool that is normally not permanently mounted on the vehicle and that supports the full set of diagnostic messages (services)
		130	On-Board Data Logger	Function for the collection and storage of data from the network that can or can not be permanently mounted on the vehicle; the data to be collected has in some fashion been identified to the unit
		131-254	Reserved for Future Assignment	
		255	Not Available	
<b>1 On-highway equipment</b>				
0	Non-specific systems			
		0-127	See Annex F	Industry non-specific
		128	Tachograph	
		129	Door Control System	
		130	Articulation Turntable Control	Control of the articulation turntable for joined body buses

131	Body to Vehicle Interface Control	Interface for managing interaction of vehicle functions and body functions; this can be a combination of body signals and gateway functionalities
132–254	Reserved for Future Assignment	
255	Not Available	
<b>1 Tractor Towing Vehicle System</b>		
0–127	See Annex F	Industry non-specific
128	Forward Road Image Processor	This function determines the vehicle position from lane markings; only for performance, advisory and warning
129–254	Reserved for Future Assignment	
255	Not Available	
<b>2 Trailer Towed Vehicle System</b>		
0–127	See Annex F	Industry non-specific
128–254	Reserved for Future Assignment	
255	Not Available	
<b>2 Agriculture and forestry equipment</b>		
<b>0 Non-specific systems</b>		
0–127	See Annex F	Industry non-specific
128	Non-Virtual Terminal Display	Implement network
129	Operator Controls — Machine Specific	
130	Task Control (Mapping Computer)	
131	Position Control	
132	Machine Control	
133	Foreign Object Detection	Detection of non desirable objects in the product flow
134	Tractor ECU	
135–254	Reserved for Future Assignment	
255	Not Available	

1	Tractor	Towing Vehicle System		Industry non-specific	
		0-127	See Annex F		
		128	Reserved for Future Assignment		
		129	Auxiliary Valve Control		
		130	Rear Hitch Control		
		131	Front Hitch Control		
		132	Tractor Machine Control		
		131-254	Reserved for Future Assignment		
		255	Not Available		
		2	Tillage		Industry non-specific
0-127	See Annex F				
128-131	Reserved for Future Assignment				
132	Tillage Machine Control				
133-254	Reserved for Future Assignment				
255	Not Available				
3	Secondary tillage			Industry non-specific	
				0-127	See Annex F
				128-131	Reserved for Future Assignment
				132	Secondary Tillage Machine Control
		133-254	Reserved for Future Assignment		
		255	Not Available		
		4	Planters/seeders	Industry non-specific	
				0-127	See Annex F
				128	Seed Rate Control
				129	Section On/Off Control
130-131	Reserved for Future Assignment				
132	Planters/Seeders Machine Control				

133	Product Flow
134	Product Level
135–254	Reserved for Future Assignment
255	Not Available

## 5 Fertilizers

0–127	See Annex F	Industry non-specific
128	Fertilize Rate Control	
129	Section On/Off Control	
130–131	Reserved for Future Assignment	
132	Fertilizers Machine Control	
133	Product Flow	
134	Product Level	
135–254	Reserved for Future Assignment	
255	Not Available	

## 6 Sprayers

0–127	See Annex F	Industry non-specific
128	Spray Rate Control	
129	Section On/Off Control	
130	Product Pressure	
131	Reserved for Future Assignment	
132	Sprayers Machine Control	
133	Product Flow	
134	Product Level	
135–254	Reserved for Future Assignment	
255	Not Available	

7 Harvesters

Industry non-specific

- 0-127 See Annex F
- 128 Tailing Monitor
- 129 Header Control
- 130 Product Loss Monitor
- 131 Product Moisture Sensor
- 132 Harvester Machine Control
- 133 Product Flow
- 134 Product Level
- 135-254 Reserved for Future Assignment
- 255 Not Available

8 Root harvesters

Industry non-specific

- 0-127 See Annex F
- 128-131 Reserved for Future Assignment
- 132 Root Harvesters Machine Control
- 133 Product Flow
- 134 Product Level
- 135-254 Reserved for Future Assignment
- 255 Not Available

9 Forage

Industry non-specific

- 0-127 See Annex F
- 128 Twine Wrapper Control
- 129-131 Reserved for Future Assignment
- 132 Forage Machine Control
- 133 Product Flow
- 134-254 Reserved for Future Assignment
- 255 Not Available



10	Irrigation	0-127 128-254 255	See Annex F Reserved for Future Assignment Not Available	Industry non-specific
11	Transport/trailer	0-127 128-254 255	Towed Vehicle System See Annex F Reserved for Future Assignment Not Available	Industry non-specific
12	Farm yard operations	0-127 128-254 255	See Annex F Reserved for Future Assignment Not Available	Industry non-specific
13	Powered auxiliary devices	0-127 128-254 255	See Annex F Reserved for Future Assignment Not Available	Industry non-specific
14	Special crops	0-127 128-254 255	See Annex F Reserved for Future Assignment Not Available	Industry non-specific
15	Earthworks	0-127 128-254 255	See Annex F Reserved for Future Assignment Not Available	Industry non-specific
16	Skidder	0-127	See Annex F	Industry non-specific

128–254	Reserved for Future Assignment	
255	Not Available	
<b>17 Sensor systems</b>		
0–127	See Annex F	Industry non-specific
128–132	Reserved for Future Assignment	
133	Product Flow	
134–254	Reserved for Future Assignment	
255	Not Available	

<b>3 Construction equipment</b>		
<b>0 Non-specific systems</b>		
0–127	See Annex F	Industry non-specific
128	Supplemental Engine Control Sensing	
129	Laser Receiver	
130	Single Land Levelling System Operator Interface	
131	Land Levelling Electric Mast	
132	Single Land Levelling System Supervisor	
133	Land Levelling System Display	
134	Laser Tracer	
135	Loader Control	
136	Slope Sensor	Measures the slope along a axis
137	Lift arm Control	Controller whose primary purpose is to control the lift arms and tilt functions on a construction loader, skid steer loader or similar machine; not a loader attachment
138	Supplemental Sensor Processing Units	ECU functioning as an I/O module connected to the network with the designed purpose of data collection (input or output) and not necessarily containing any control algorithms or processing intelligence
139	Hydraulic System Planner	Coordinates the functions of a number of valve controllers

		Hydraulic Valve Controller	The valve controller will typically control the flow of oil to a specific cylinder
1	Skid steer loader	140	Hydraulic Valve Controller
		141	Joystick Control
		142-254 255	Reserved for Future Assignment Not Available
2	Articulated dump truck	128	Main Controller
		129-254 255	Reserved for Future Assignment Not Available
		128-254 255	Reserved for Future Assignment Not Available
3	Backhoe	128-254 255	Reserved for Future Assignment Not Available
		128-254 255	Reserved for Future Assignment Not Available
		128-254 255	Reserved for Future Assignment Not Available
4	Crawler	128-254 255	Reserved for Future Assignment Not Available
		128-254 255	Reserved for Future Assignment Not Available
		128-254 255	Reserved for Future Assignment Not Available
5	Excavator	128-254 255	Reserved for Future Assignment Not Available
		128-254 255	Reserved for Future Assignment Not Available
		128-254 255	Reserved for Future Assignment Not Available
6	Forklift	128-254 255	Reserved for Future Assignment Not Available
		128-254 255	Reserved for Future Assignment Not Available
		128-254 255	Reserved for Future Assignment Not Available
7	Four wheel drive loader	128-254 255	Reserved for Future Assignment Not Available
		128-254 255	Reserved for Future Assignment Not Available
		128-254 255	Reserved for Future Assignment Not Available

8		Grader		
128	HFWD Controller		Hydraulic front wheel drive controller	
129-254	Reserved for Future Assignment			
255	Not Available			
9-254		Reserved for Future Assignment		
128-254	Reserved for Future Assignment			
255	Not Available			
127		Not Available		
128-254		Reserved for Future Assignment		
255	Not Available			
4		Marine		
0		Non-specific systems		
0-127	See Annex F		Industry non-specific	
128	Marine Engines Alarm System		ECU that controls the Alarm functions on an engine of a Marine System	
129	Marine Engines Protection System		First ECU that controls the Protection functions on the first engine of a Marine System	
130	Marine Engines Protection System Display		ECU that provides the display of information and/or indicators associated specifically with the protection system on an engine of a Marine System	
131-254		Reserved for Future Assignment		
255	Not Available			
10		System tools		
0-127	See Annex F		Industry non-specific	
128-254		Reserved for Future Assignment		
255	Not Available			

20	Safety systems					
		0–127	See Annex F		Industry non-specific	
		128–254	Reserved for Future Assignment			
		255	Not Available			
25	Gateway					
		0–9	See Annex F		Industry non-specific	
		10	Gateway			
		11–127	See Annex F		Industry non-specific	
		128–254	Reserved for Future Assignment			
		255	Not Available			
30	Power management and lighting systems					
		0–127	See Annex F		Industry non-specific	
		128–129	Reserved for Future Assignment			
		130	Switch			
		131–139	Reserved for Future Assignment			
		140	Load			
		141–254	Reserved for Future Assignment			
		255	Not Available			
40	Steering systems					
		0–127	See Annex F		Industry non-specific	
		128–129	Reserved for Future Assignment			
		130	Follow-up Controller			
		131–139	Reserved for Future Assignment			
		140	Mode Controller			
		141–149	Reserved for Future Assignment			
		150	Automatic Steering Controller			

- 151–159 Reserved for Future Assignment
- 160 Heading Sensors
- 161–254 Reserved for Future Assignment
- 255 Not Available

50 Propulsion systems

Industry non-specific

- 0–127 See Annex F
- 128–129 Reserved for Future Assignment
- 130 Engine room monitoring
- 131–139 Reserved for Future Assignment
- 140 Engine Interface
- 141–149 Reserved for Future Assignment
- 150 Engine Controller
- 151–159 Reserved for Future Assignment
- 160 Engine Gateway
- 161–169 Reserved for Future Assignment
- 170 Control Head
- 171–179 Reserved for Future Assignment
- 180 Actuator
- 181–189 Reserved for Future Assignment
- 190 Gauge Interface
- 191–199 Reserved for Future Assignment
- 200 Gauge Large
- 201–209 Reserved for Future Assignment
- 210 Gauge Small
- 211–254 Reserved for Future Assignment
- 255 Not Available

		Industry non-specific
0–127	See Annex F	
128–129	Reserved for Future Assignment	
130	Sounder, depth	
131–139	Reserved for Future Assignment	
140	Reserved for Future Assignment	
141–144	Reserved for Future Assignment	
145	Global Navigation Satellite System (GNSS)	
146–149	Reserved for Future Assignment	
150	Loran C	
151–155	Reserved for Future Assignment	
155	Speed Sensors	
156–159	Reserved for Future Assignment	
160	Turn Rate Indicator	
161–169	Reserved for Future Assignment	
170	Integrated Navigation	
171–199	Reserved for Future Assignment	
200	Radar and/or Radar Plotting	
201–204	Reserved for Future Assignment	
205	Electronic Chart Display & Information System (ECDIS)	
206–209	Reserved for Future Assignment	
210	Electronic Chart System (ECS)	
211–219	Reserved for Future Assignment	
220	Direction Finder	
221–254	Reserved for Future Assignment	
255	Not Available	

70 Communications systems

0-127	See Annex F	Industry non-specific
128-129	Reserved for Future Assignment	
130	Emergency Position Indicating Beacon (EPIRB)	
131-139	Reserved for Future Assignment	
140	Automatic Identification System	
141-149	Reserved for Future Assignment	
150	Digital Selective Calling (DSC)	
151-159	Reserved for Future Assignment	
160	Data Receiver	
161-169	Reserved for Future Assignment	
170	Satellite	
171-179	Reserved for Future Assignment	
180	Radio-Telephone (MF/HF)	
181-189	Reserved for Future Assignment	
190	Radio-Telephone (VHF)	
191-254	Reserved for Future Assignment	
255	Not Available	

80 Instrumentation/general systems

0-127	See Annex F	Industry non-specific
128-129	Reserved for Future Assignment	
130	Time/Date systems	
131-139	Reserved for Future Assignment	
140	Voyage Data Recorder	
141-149	Reserved for Future Assignment	
150	Integrated Instrumentation	



151–159	Reserved for Future Assignment
160	General Purpose Displays
161-169	Reserved for Future Assignment
170	General Sensor Box
171–179	Reserved for Future Assignment
180	Weather Instruments
1181-189	Reserved for Future Assignment
190	Transducer/general
191–199	Reserved for Future Assignment
200	NMEA 0183 Converter
201–254	Reserved for Future Assignment
255	Not Available

#### 90 Environmental (HVAC) systems

0–127	See Annex F	Industry non-specific
128–254	Reserved for Future Assignment	
255	Not Available	

#### 100 Deck, cargo, and fishing equipment systems

0–127	See Annex F	Industry non-specific
128–254	Reserved for Future Assignment	
255	Not Available	

#### 127 Not Available

0–127	See Annex F	Industry non-specific
128–254	Reserved for Future Assignment	
255	Not Available	

**5 Industrial/process control/stationary**  
 0 Non-specific systems

0-127	See Annex F	Industry non-specific
128	Supplemental Engine Control Sensing	
129	Generator Set Controller	Generator set controller used to collect data and control.
130-254	Reserved for Future Assignment	
255	Not Available	

## Annex F (normative)

### ISO 11783 All industry NAMES

The NAME fields are specified in ISO 11783-5. This annex defines the lower 128 functions that are independent of the industry group and device class. These functions are used within all industry groups — distinguishing them from industry group 0, which is an industry group itself but applicable to all industries.

Value	Function	Description
0	Engine	While the function identifies the typical mechanical power source of the machine, the reference tends to be to the management system that controls the torque vs. speed vs. command (typically throttle) of that power source
1	Auxiliary Power Unit (APU)	Power source for operating systems without the use of the prime “drive” engine
2	Electric Propulsion Control	Control system which operates the drive mechanism when it is electrically powered, such as battery-motor or engine generator–motor hybrids
3	Transmission	Mechanical system for altering the speed vs. torque output of the engine to a level usable by another system on the machine, although the network reference is actually to the system that controls the operation of said transmission
4	Battery Pack Monitor	Monitors the condition — charge, temperature and power remaining for an internal battery pack — typically used with electric propulsion
5	Shift Control	Unit that determines and transmit onto the network the gear, the range, the operating mode, or any or all of these that the operator desires for the transmission (not to be confused with transmission control, i.e. transmission)
6	Power Take-Off Control – Rear or Primary	System that controls the mechanical power derived from a prime engine and used to operate auxiliary items such as compressors in on highway vehicles and such as implements in AG applications —can be the main or rear unit
7	Axle — Steering	Adjusts attack angle as function of steering
8	Axle — Driving	

9	Brakes — System Control	Controls service braking system electronically — can be any of a number of schemes — and can also control (at least partly) the endurance braking system in the sense of an integrated control (application phased in with the service braking system)
10	Brakes — Steer Axle Control	Control for actuating the service brakes on a steered axle
11	Brakes — Drive Axle Control	Control for actuating the service brakes on a drive axle
12	Retarder — Engine	Controller for the retarder capabilities of the engine (there are several types of retarder possible, defined within the parameter Retarder Type, SPN 901)
13	Retarder — Driveline	Controller for the retarder capabilities of the driveline (there are several types of retarder possible, defined within the parameter Retarder Type, SPN 901)
14	Cruise Control	Control system for maintaining the vehicle's speed at a fixed operator selectable value with various over-rides linked to other systems
15	Fuel System	Controls fuel flow from the tank to the filter to the water removal/separator to the engine and then back to the tank
16	Steering Control	Controls steering in steer-by-wire
17	Suspension Control — Steer Axle	Control system for the suspension of a steered axle
18	Suspension Control — Drive Axle	Control system for the suspension of a driven axle
19	Instrument Cluster	Gauge display for a vehicle, typically mounted within the field of view of the driver in the cab and generally a limited display such as dedicated dials or a small digit seven segment display (see Cab Display for larger more elaborate display)
20	Trip Recorder	System for accumulating data versus travel of the vehicle (machine), since a specific starting point sometimes expressed in terms of distance or time travelled
21	Cab Climate Control	System for controlling the climate within the cab of the vehicle (machine); the operator controls (message) for this system should be designed to allow any source to transmit them
22	Aerodynamic Control	Modify drag by altering body panels — lower air fairings when dead heading, extend side panels when on interstate
23	Vehicle Navigation	System associated with the vehicles physical location — can be as simple as display of current location, driving instructions from current to desired location
24	Vehicle Security	System for comparing operator-provided data sequences against reference to verify that operation or certain operations be allowed for the particular operator, and which

can also may include functions to prevent unauthorized operations, for example, unlocking doors or starting engine

25	Network Interconnect Unit	ECU for connecting different network segments together — can be bridge or gateway — see ISO 11783-4 for details, for use on any vehicle system (tractor or trailer)
26	Body Control	Can handle suspension control for the body sections independent from the axle sections — controls the body (not chassis or cab) components
27	Power Take-Off Control — Front or Secondary	System that controls the mechanical power derived from a prime engine and used to operate auxiliary items such as compressors in on highway vehicles and such as implements in agriculture applications — this can be the secondary or front unit
28	Off-Vehicle Gateway	ECU for connecting between vehicle network(s) and an off-vehicle system or network, such as fleet management, connection can be wireless, performs gateway functions, i.e. filters messages, translates between protocols
29	Virtual Terminal	General-purpose “intelligent” display with a specific message set (ISO 11783-6) specifically mounted in cab for the operator’s use and which can be connected to the drive train segment of the network and/or to the implement network segment in an AG application
30	Management Computer #1	Manages vehicle systems, i.e. powertrain
31	Propulsion Battery Charger	Unit used to charge propulsion batteries in an electric vehicle from an off-board source of electrical energy
32	Headway Control	Forward-looking collision avoidance, collision warning, speed controller, or speed matching
33	System Monitor	
34	Hydraulic Pump Control	Pump controller that provides hydraulic power to operate installed equipment such as man buckets, cranes, augers, shredders, example vehicles including digger derrick (plants telephone poles) and bucket truck — thus, being the controller for said pump
35	Suspension — System Control	Controller responsible for coordinating the over-all suspension of a vehicle — can cause interaction between the axle suspension controls and the body controller
36	Pneumatic — System Control	

37	Cab Controller	Controller located in/near vehicle cab used to perform functions that are grouped together for convenience and proximity — can handle any number of vehicle specific items but not other specifically NAME(d) functions (such as instrument cluster), and prime use of which would be to read cab-mounted operator controls (not handled by any other specific unit) and to then transmit the associated messages onto the network
38	Tyre Pressure Control	Unit that provides control of centralized tyre inflation
39	Ignition Control	Unit for altering the ignition of an engine and with which an engine controller can communicate
40	Seat Control	System for controlling the seats (operator and passenger) within the cab of the vehicle (machine) — can include control of the position and suspension of seat; the operator controls (message) for the seat system should be designed to allow any source to transmit them
41	Operator Controls — Lighting	Controller for sending the operator lighting controls messages when they are coming from a unit dedicated to transmitting these specific messages on the network
42	Water Pump Control	Controller for a water pump mounted on the vehicle/machine (e.g. emergency equipment with pump for pumping water onto fire; utilities delivery truck for delivery of fluids such as water to remote areas)
43	Transmission Display	Display designed specifically to display transmission information, such as the transmission gear
44	Exhaust Emission Control	
45	Vehicle Dynamic Stability Control	
46	Oil System Monitor	
47	Information System Control	Information management for a vehicle's application, such as transit passenger/fare monitoring and truck cargo management — handles grouping and processing data into information displays to be presented to driver and also enforces the DI rules for interfacing with driver
48	Ramp Control	Loading unloading — chairlift, ramps, lifts or tailgates
49	Clutch/Converter Control	When transmission is distributed this handles torque converter lock-up or engine — transmission connection

50	Auxiliary Heater	Primary heat typically being taken from the engine coolant, heater for use without the prime "drive" engine operating or when it is unable to supply sufficient heat — can be fuel-fired, electrical or other type of heating source and can use air, water or other transfer media
51	Forward-Looking Collision Warning System	System which detects and warns of impending collision with object in path of present forward travel (not to be confused with #32, Headway Controller)
52	Chassis Control	Controls the chassis (not body or cab) components (see website for RLs definitions of body, chassis, drive train)
53	Alternator/Electrical Charging System	Vehicle's primary on-board charging controller — alternator used to generate electrical power for vehicle electrical system and storage battery
54	Communications, Cellular	Radio communications unit designed specifically to communicate via the <i>cellular telephone system</i> — can be either a receiver only, a transmitter only or a transceiver
55	Communications, Satellite	Radio communications unit designed specifically to communicate via some satellite system — can be either receiver only, transmitter only or transceiver
56	Communications, Radio	Radio communications unit designed specifically to communicate via a terrestrial point-to-point system — can be either receiver only, transmitter only or transceiver
57	Operator Controls, Steering Column	Unit that gathers the operator inputs from switches/levers/etc. located in and/or around the steering wheel/column and transmits the associated messages on the network, when a separate NAME is needed for this unit (i.e. other units might be sending the messages and this unit not exist on the network)
58	Fan Drive Control	Primary control system affecting the operation of the main cooling fan on the engine coolant — other systems can send commands or requests to this unit
59	Starter	Mechanical system for initiating rotation in an engine that is stopped — this reference is more for the system that controls the starter than the starter itself
60	Cab Display Cab	Used for a fairly elaborate in cab display, typically capable of greater than 30 ASCII characters and differentiated from the Instrument Cluster and Virtual Terminal
61	File Server/Printer	Printing or file storage unit on the network — a permanent connection can exist and the unit is expected to be able to print (paper type output) or store data (as in magnetic or EEPROM components)

62	On-Board Diagnostic Unit	Tool that can be permanently mounted on the vehicle and which may not support all of the ISO 11783-12 <sup>4</sup> ) messages
63	Engine Valve Controller	Control system used to manipulate the actuation of engine intake and/or exhaust valves in response to other factors
64	Endurance Braking	Sum of all units in a vehicle which enable the driver with virtually no friction brake wear/tear to reduce speed or maintain the speed on a long descent — can contain energy supplying unit(s), control unit(s), transmission(s), retarder(s) and energy dissipation unit(s); the control can be independent of the service brake system or can be integrated with the service brake control such that both are applied simultaneously or in a phased fashion, whereas an integrated system can also have a control to prevent linking of operation
65	Gas Flow Measurement	Provides measurement of gas flow rates and associated parameters
66	I/O Controller	Reporting and/or control unit for external input and output channels
67	Electrical System Controller	Can include load centres, fuse boxes and power distribution boards
68 to 127	Reserved for Future Assignment	

---

4) To be published.



## Annex G (normative)

### ISO 11783 manufacturer codes

Value	Manufacturer	Location
0	Reserved	
1	Allied Signal Inc.	Elyria, OH USA
2	Allison Transmission, GMC	Indianapolis, IN USA
3	Ametek, US Gauge Division	Sellersville, PA USA
4	Ametek-Dixson	Grand Junction, CO USA
5	AMP Inc.	Harrisburg, PA USA
6	Berfors Electronics AB	Stockholm, Sweden
7	Case Corp.	Burr Ridge, IL USA
8	Caterpillar Inc.	Peoria, IL USA
9	Chrysler Corp.	Auburn Hills, MI USA
10	Cummins Engine Co.	Columbus, IN USA
11	Dearborn Group Inc.	Indianapolis, IN & Farmington Hills, MI USA
12	Deere & Company, Precision Farming	East Moline, IL USA
13	Delco Electronics	Kokomo, IN USA
14	Detroit Diesel Corporation	Detroit, MI USA
15	Dickey-john Corp.	Auburn, IL USA
16	Eaton Corp.	Southfield, MI USA
17	Eaton Corp., Corp. Res. & Dev.	Milwaukee, WI USA
18	Eaton Corp., Transmission Div.	Kalamazoo, MI USA

19	Eaton Corp. Trucking Info Services	Clemmons, NC USA
20	Eaton Ltd	Worsley, England
21	Echlin Inc., Midland Brake Inc.	Kansas City, MO USA
22	Ford Motor Co., Electronic Concepts & Systems	Dearborn, MI USA
23	Ford Motor Co., Heavy Truck	Dearborn, MI USA
24	Ford Motor Co., Vehicle Controls	Dearborn, MI USA
25	Freightliner Corp.	Portland, OR USA
26	General Motors Corp., Service Technology Grp	Romulus, MI USA
27	GMC	Troy, MI USA
28	Grote Ind. Inc.	Madison, IN USA
29	Hino Motors Ltd	Tokyo, Japan
30	Isuzu Motors Ltd	Kawasaki, Japan
31	J. Pollak Corp.	Boston, MA USA
32	Jacobs Vehicle Systems	Bloomfield, CT USA
33	John Deere	Waterloo, IA USA
34	Kelsey Hayes Co.	Livonia, MI USA
35	Kenworth Truck Co.	Kirkland, WA USA
36	Lucas Ind.	Solihull, West Midlands, England
37	Mack Trucks Inc.	Hagerstown, MD USA
38	Micro Processor Systems Inc.	Sterling Hts, MI USA
39	Microfirm Inc.	Stillwater, OK USA
40	Motorola AIEG Inc.	Northbrook, IL USA
41	Motorola Inc.	Schaumburg, IL USA
42	International Truck and Engine Corporation — Engine Electronics (formerly Navistar Intl. Trans. Co., Engine Electronics)	Warrenville, IL USA
43	International Truck and Engine Corporation — Vehicle Electronics (formerly Navistar Intl Trans Corp.)	Warrenville, IL USA

44	Nippondenso Co. Ltd	Kariya Aichi, Japan
45	PACCAR	Mount Vernon, WA USA
46	Parasoft Computing Solutions	Winston Salem, NC USA
47	Phillips Semiconductor	Sunnyvale, CA USA
48	Pollak Alphabet	El Paso, TX USA
49	RE America Inc.	Cleveland, OH USA
50	Robert Bosch Corp.	Broadview, IL USA
51	Robert Bosch GmbH	Stuttgart, Germany
52	Meritor Automotive, Inc. (formerly Rockwell Automotive)	Troy, MI USA
53	Rockwell Land Transportation	Cedar Rapids, IA USA
54	Meritor Wabco	Troy, MI USA
55	Ryder System Inc.	Miami, FL USA
56	SAIC	San Diego, CA USA
57	Sauer-Danfoss Co. (formerly Sauer Sundstrand Co.)	Minneapolis, MN USA
58	SPX Corporation, OTC Div.	Owatonna, MN USA
59	VES Inc.	Rock Hill, SC USA
60	Volvo Trucks North America Inc.	Greensboro, NC USA
61	Volvo Truck Corp.	Gothenburg, Sweden
62	Wabco	Hanover, Germany
63	ZF Industries Inc.	Vernon Hills, IL USA
64	unused (formerly SpectraPrecision Laserplane, then SpectraPhysics)	
65	MAN Nutzfahrzeuge AG	Munich, Germany
66	John Deere Construction Equipment Division	Dubuque, IA USA
67	Funk Manufacturing Company	Coffeyville, KS USA
68	Scania	Södertälje, Sweden

69	Trimble Navigation	
70	Flex-coil Limited	Saskatoon, SK Canada
71	Vansco Electronics Ltd	Winnipeg, MB Canada
72	Sisu Corporation	Espoo, Finland
73	LeTourneau, Inc.	Longview, TX USA
74	Eaton Axle-Brake Division	Kalamazoo, MI USA
75	Deere & Co., Agricultural Division	
76	unused (formerly Deere & Co., Construction Division)	
77	Deere Power Systems Group	
78	Frank W. Murphy Manufacturing, Inc.	Tulsa, OK USA
79	Daimler Benz AG – Engine Division (PBM)	Stuttgart, Germany
80	Twin Disc, Inc.	Racine, WI USA
81	Fire Research Corp.	Nesconset, NY USA
82	Bobcat/Ingersoll-Rand (formerly Melroe/Ingersoll-Rand)	Fargo, ND USA
83	Eaton VORAD Technologies	San Diego, CA USA
84	New Holland UK Limited	Basildon, Essex, UK
85	Kohler Co.	Kohler, WI USA
86	C. E. Niehoff & Company	Evanston, IL USA
87	J.C. Bamford Excavators Ltd (JCB)	Rocester, Staffordshire, UK
88	Satloc Precision GPS	Scottsdale, AZ USA
89	Kverneland Group, Electronics Division	Nieuw-Venep, Netherlands
90	Knorr-Bremse SfN GmbH	Munich, Germany
91	BSG Bodensee Steuergesellschaft GmbH	Immenstaad, Germany
92	Ag-Chem Equipment Co., Inc.	Minnetonka, MN USA
93	Perkins Engines Company Ltd	Peterborough, UK
94	CNH Global N.V.	Racine, WI USA

95	Pacific Insight Electronics Corp.	Nelson, BC Canada
96	Mech@tronic IT GmbH	Hetzenhausen, Germany
97	Ag Leader Technology, Inc.	Ames, IA USA
98	Mueller-Elektronik GmbH & Co.	Salzkotten, Germany
99	International Transmissions Ltd (ITL)	Wrexham, North Wales, UK
100	VDO Technik AG	Rüthi, Switzerland
101	Sensoria	San Diego, CA USA
102	AGCO GmbH & Co.	Marktobendorf, Germany
103	Agrocom GmbH & Co. Agrarsystem KG	Bielefeld, Germany
104	Claas Selbstfahrende Erntemaschinen GmbH	Harsewinkel, Germany
105	Kiepe Elektrik GmbH & Co. KG	Duesseldorf, Germany
106	BAE Systems Controls, Inc.	Johnson City, NY USA
107	Grimme Landmaschinen GmbH & Co. KG	Damme, Germany
108	WTK-Elektronik GmbH	Neustadt, Germany
109	LH Technologies ApS	Aabybro, Denmark
110	EPIQ Sensor-Nite	Fenton, MI USA
111	Maschinenfabrik Bernhard Krone GmbH	Spelle, Germany
112	MECALAC	Annecy le Vieux, France
113	Stress-Tek, Inc.	Kent, WA USA
114	EControls, Inc.	San Antonio, TX USA
115	NACCO Materials Handling Group, Inc.	Portland, OR USA
116	BEELINE Technologies	Brisbane, QLD Australia
117	HUSCO International	Waukesha, WI USA
118	Intron GmbH S	Chwaebisch Hall, Germany
119	IntegriNautics	Menlo Park, CA USA
120	RDS Technology Ltd	Minchinhampton, Stroud, UK

121	HED (Hydro Electronic Devices, Inc.)	Hartford, WI USA
122	FG Wilson (Engineering) Limited	Larne, County Antrim, UK
123	Basler Electric	Highland, IL USA
124	Hydac Electronic	Saarbruecken, Germany
125	Nevada Automotive Test Center	Carson City, NV USA
126	Driver Tech	Salt Lake City, UT USA
127	Holland USA	Holland, MI USA
128	Gerhard Duecker GmbH & Co. KG	Stadtlohn, Germany
129	OMNEX Control Systems Inc.	Port Coquitlam, BC, Canada
130	Nido — Universal Machines B.V.	Holten, Netherlands
131	ITT Industries	Eden Prairie, MN USA
132	Mulag-Fahrzeugwerk	Oppenau, Germany
133	Bucher Schoering GmbH	Hannover, Germany
134	Iris Technology Ltd	Lancaster, Lancs., UK
135	Airmar Technology Corporation	Milford, NH USA
136	Komatsu Ltd Hiratsuka	Kanagawa, Japan
137	Maretron	Phoenix, AZ USA
138	Georg Fritzmeier GmbH & Co. KG	Grosshelfendorf, Germany
139	Caterpillar Trimble Control Technologies (CTCT), LLC	Dayton, OH USA
140	Lowrance Electronics, Inc.	Tulsa, OK USA
141	Thales Navigation Ltd.	Surrey, UK
142	TRW Automotive (Commercial Steering Systems)	Lafayette, IN USA
143	W. Gmeiner GmbH & Co.	Kummersbruck, Germany
144	Mercury Marine	Fond du Lac, WI USA
145	MurCal Controls	Palmdale, CA USA
146	Maxima Technologies	Lancaster, PA USA

147	Nautibus electronic GmbH	Quern, Germany
148	Blue Water Data, Inc.	Salem, NJ USA
149	Holset	Charleston, SC USA
150	Fleetguard	Nashville, TN USA
160	Nido	Nijbroek, The Netherlands
171	Wachendorff Elektronik GmbH	Geisenheim, Germany
1850	Teleflex	Limerick, PA USA
1851	RayMarine Portsmouth	Hampshire, UK
1852	Navionics	Wareham, MA USA
1853	Japan Radio Co.	Seattle, WA USA
1854	Northstar Technologies	Acton, MA USA
1855	Furuno USA	Camas, WA USA
1856	Trimble	Sunnyvale, CA USA
1857	Simrad Egersund	Norway
1858	Lifton	Charlottesville, VA USA
1859	Kvasar AB	Kinnahult, Sweden
1860	MMP	Fircrest, WA USA
1861	Vector Cantech	Novi, MI USA

**Annex H**  
(informative)

**ISO 11783 Request forms**

**General requestor information**

Please complete the requestor's information section to provide information on how ISO/TC 23/SC 19/WG 1 can contact you. Please enter your e-mail address, as this is the primary method WG 1 will use to communicate with you.

First and last name:	
Company:	
Address:	
City:	
State/Province:	
Country:	
Postal Code:	
Phone:	
Fax:	
E-mail:	
Request date (yyyy-mm-dd):	

**Requested subject**

--



**Parameter group number (PGN)**

Complete this section to request a new PGN or modify an existing one (e.g. to add or modify one of its parameters). Refer to the template given in ISO 11783-3: —<sup>5</sup>, Table 7, for the information to be provided. To request or modify more than one PGN, duplicate this section and fill it in for each PGN. Note that the PGN broadcast rate and message priority *cannot be revised*.

What is the request (new or modify PGN)?	
PGN number to be revised, if modifying only:	
PGN name:	
Proposed acronym:	
PGN type:	
Data length in bytes:	
Is this a multi-packet message?	
Desired broadcast rate of the message:	
Desired message priority:	

**PGN description**

---

5) To be published. (Revision of ISO 11783-3:1989)

**Parameter/slot**

Complete this section to request a new parameter, modify a current parameter or add a slot. Refer to ISO 11783-7 for the information to be provided. If this section is for a parameter, it is to be associated with the PGN listed above. To request or modify more than one parameter, duplicate this section and fill it in for each parameter.

What is the request (new parameter or modify)?	
Parameter to be revised:	
Proposed name of new parameter:	
Parameter starting byte and bit:	
Parameter type:	
If parameter will use existing slot, pick from list:	
If parameter requires a new slot, fill in the following:	
Slot type:	
Engineering units:	
Scaling (slot resolution, engineering units per bit):	
Limits (slot range, engineering units):	
Offset (engineering units):	
Parameter length (in number of bits):	
Operational range, if different than slot range above:	

**Parameter and/or slot description**

--

**If this request is for a “state and status” parameter, list the bit states and their definitions:**

--

**Requestor's notes to ISO TC 23/SC 19/WG 1**

--

**Industry Group 2 — Agricultural and forestry equipment — Specific NAMES**

Complete this section for to request a new NAME or modify a current NAME. Refer to ISO 11783-5, for the information to be provided. To request or modify more than one NAME, duplicate this section and fill it in for each parameter.

What is the request (new or modify NAME)?	
Device class value to be revised:	
Function value to be revised:	

**Device class description**

--

**Function description**

--

**Requestor's notes to ISO TC 23/SC 19/WG 1**

**Manufacturer code**

Complete this section to request a new manufacturer code or modify an existing one.

What is the request (new or modify code)?	
Manufacturer code number to be revised:	
New or modified manufacturer's name (include division/department):	
New or modified location (city, state/province, country):	

**Requestor's notes to ISO TC 23/SC 19/ WG 1**

**Request form completion instructions**

- a) Follow the instructions in each section when completing them.
- b) Identify the request by using a document name with the following format; YYYYMMDDii\_x

where

YYYY is the year;

MM is the month;

DD is the day;

ii are the initials of the person requesting the code;

x is the number of the request complete for the date indicated.

EXAMPLE If John Smith submitted a single request on 2005 March 30, the request document name would be "20050330js\_1". If he submitted two requests on that same day, the second request document name would be "20050330js\_2".

- c) If more detailed text, graphs, drawing or data would be helpful in explaining the request, submit them with the request. The document name shall be the same as the request document, with the addition of the extension "\_sup".

EXAMPLE Following on from the example given in b), the document name "20050330js\_1\_sup" would be included with the request documents.

- d) Before sending the request, please consider the following.
- Are all the necessary fields of the request form completed?
  - Is the document number format of the request correct?
  - Company-specific terminology not used?
  - Are the PGN explanations clear? Can another person read and understand the request? Will someone in another company understand the request?
  - Universal wording has been used such that the request is acceptable for use in the standard.
- e) Send the request to:

TC 23/SC 19/WG 1 Secretariat  
 VDMA  
 Standardization Group  
 Agricultural Machinery  
 Lyoner Strasse 18  
 D-60528 Frankfurt/Main  
 GERMANY

Fax: ++49 69 6603 2301

## Bibliography

- [1] CAN Specification Version 2.0 Part B, Robert Bosch GmbH, September 1991
- [2] ISO 3339-0, *Tractors and machinery for agriculture and forestry — Classification and terminology — Part 0: Classification system and classification*
- [3] ISO 7498 (all parts), *Information processing systems — Open Systems Interconnection — Basic Reference Model*
- [4] ISO 11519-1, *Road vehicles — Low-speed serial data communication — Part 1: General and definitions*
- [5] ISO 11898 (all parts), *Road vehicles — Controller area network (CAN)*
- [6] ISO 11992 (all parts), *Road vehicles — Interchange of digital information on electrical connections between towing and towed vehicles*
- [7] ISO 15765 (all parts), *Road vehicles — Diagnostics on Controller Area Networks (CAN)*
- [8] IEC 61162-3, *Maritime navigation and radiocommunication equipment and systems — Digital interfaces — Part 3: Serial data instrument network<sup>6)</sup>*
- [9] SAE J 1939, *Recommended Practice for Control and Communications Network for On-Highway Equipment*
- [10] SAE J 1939-21, *Data Link Layer*
- [11] SAE J 1939-31, *Network Layer*
- [12] SAE J 1939-71, *Vehicle Application Layer*
- [13] SAE J 1939-73, *Application Layer — Diagnostics*
- [14] SAE J 1939-74, *Application — Configurable Messaging*
- [15] SAE J 1939-81, *Network Management*
- [16] SAE J 1939-75, *Application Layer — Generator Sets and Industrial*
- [17] ITU M.493-9, *Digital selective-calling system for use in the maritime mobile service*
- [18] ITU M.821-1, *Optional expansion of the digital selective-calling system for use in the maritime mobile service*
- [19] NMEA 0183, <http://www.nmea.org/pub/0183><sup>7)</sup>

---

6) Under preparation.

7) National Marine Electronics Association standard.



---

---

## BSI — British Standards Institution

BSI is the independent national body responsible for preparing British Standards. It presents the UK view on standards in Europe and at the international level. It is incorporated by Royal Charter.

### Revisions

British Standards are updated by amendment or revision. Users of British Standards should make sure that they possess the latest amendments or editions.

It is the constant aim of BSI to improve the quality of our products and services. We would be grateful if anyone finding an inaccuracy or ambiguity while using this British Standard would inform the Secretary of the technical committee responsible, the identity of which can be found on the inside front cover.  
Tel: +44 (0)20 8996 9000. Fax: +44 (0)20 8996 7400.

BSI offers members an individual updating service called PLUS which ensures that subscribers automatically receive the latest editions of standards.

### Buying standards

Orders for all BSI, international and foreign standards publications should be addressed to Customer Services. Tel: +44 (0)20 8996 9001.  
Fax: +44 (0)20 8996 7001. Email: [orders@bsi-global.com](mailto:orders@bsi-global.com). Standards are also available from the BSI website at <http://www.bsi-global.com>.

In response to orders for international standards, it is BSI policy to supply the BSI implementation of those that have been published as British Standards, unless otherwise requested.

### Information on standards

BSI provides a wide range of information on national, European and international standards through its Library and its Technical Help to Exporters Service. Various BSI electronic information services are also available which give details on all its products and services. Contact the Information Centre.  
Tel: +44 (0)20 8996 7111. Fax: +44 (0)20 8996 7048. Email: [info@bsi-global.com](mailto:info@bsi-global.com).

Subscribing members of BSI are kept up to date with standards developments and receive substantial discounts on the purchase price of standards. For details of these and other benefits contact Membership Administration.  
Tel: +44 (0)20 8996 7002. Fax: +44 (0)20 8996 7001.  
Email: [membership@bsi-global.com](mailto:membership@bsi-global.com).

Information regarding online access to British Standards via British Standards Online can be found at <http://www.bsi-global.com/bsonline>.

Further information about BSI is available on the BSI website at <http://www.bsi-global.com>.

### Copyright

Copyright subsists in all BSI publications. BSI also holds the copyright, in the UK, of the publications of the international standardization bodies. Except as permitted under the Copyright, Designs and Patents Act 1988 no extract may be reproduced, stored in a retrieval system or transmitted in any form or by any means – electronic, photocopying, recording or otherwise – without prior written permission from BSI.

This does not preclude the free use, in the course of implementing the standard, of necessary details such as symbols, and size, type or grade designations. If these details are to be used for any other purpose than implementation then the prior written permission of BSI must be obtained.

Details and advice can be obtained from the Copyright & Licensing Manager.  
Tel: +44 (0)20 8996 7070. Fax: +44 (0)20 8996 7553.  
Email: [copyright@bsi-global.com](mailto:copyright@bsi-global.com).