

BS ISO 11722:2013



BSI Standards Publication

Solid mineral fuels — Hard coal — Determination of moisture in the general analysis test sample by drying in nitrogen

bsi.

...making excellence a habit.™

National foreword

This British Standard is the UK implementation of ISO 11722:2013. It supersedes BS 1016-104.1:1999 which is withdrawn.

The UK participation in its preparation was entrusted to Technical Committee PTI/16, Solid mineral fuels.

A list of organizations represented on this committee can be obtained on request to its secretary.

This publication does not purport to include all the necessary provisions of a contract. Users are responsible for its correct application.

© The British Standards Institution 2013. Published by BSI Standards Limited 2013

ISBN 978 0 580 80382 6

ICS 73.040

Compliance with a British Standard cannot confer immunity from legal obligations.

This British Standard was published under the authority of the Standards Policy and Strategy Committee on 31 July 2013.

Amendments issued since publication

Date	Text affected
------	---------------

**Solid mineral fuels — Hard coal —
Determination of moisture in the
general analysis test sample by
drying in nitrogen**

*Combustibles minéraux solides — Houille — Détermination
de l'humidité de l'échantillon pour analyse par dessiccation en
atmosphère d'azote*





COPYRIGHT PROTECTED DOCUMENT

© ISO 2013

All rights reserved. Unless otherwise specified, no part of this publication may be reproduced or utilized otherwise in any form or by any means, electronic or mechanical, including photocopying, or posting on the internet or an intranet, without prior written permission. Permission can be requested from either ISO at the address below or ISO's member body in the country of the requester.

ISO copyright office
Case postale 56 • CH-1211 Geneva 20
Tel. + 41 22 749 01 11
Fax + 41 22 749 09 47
E-mail copyright@iso.org
Web www.iso.org

Published in Switzerland

Contents

	Page
Foreword.....	iv
Introduction.....	v
1 Scope.....	1
2 Normatives references.....	1
3 Terms and definitions.....	1
4 Principle.....	1
5 Reagent.....	1
6 Apparatus.....	1
7 Preparation of the test sample.....	2
8 Procedure.....	2
9 Expression of results.....	2
10 Precision.....	2
10.1 Repeatability limit.....	2
10.2 Reproducibility limit.....	2
11 Test report.....	3
Annex A (informative) Example of a suitable oven.....	4

Foreword

ISO (the International Organization for Standardization) is a worldwide federation of national standards bodies (ISO member bodies). The work of preparing International Standards is normally carried out through ISO technical committees. Each member body interested in a subject for which a technical committee has been established has the right to be represented on that committee. International organizations, governmental and non-governmental, in liaison with ISO, also take part in the work. ISO collaborates closely with the International Electrotechnical Commission (IEC) on all matters of electrotechnical standardization.

The procedures used to develop this document and those intended for its further maintenance are described in the ISO/IEC Directives, Part 1. In particular the different approval criteria needed for the different types of ISO documents should be noted. This document was drafted in accordance with the editorial rules of the ISO/IEC Directives, Part 2. www.iso.org/directives

Attention is drawn to the possibility that some of the elements of this document may be the subject of patent rights. ISO shall not be held responsible for identifying any or all such patent rights. Details of any patent rights identified during the development of the document will be in the Introduction and/or on the ISO list of patent declarations received. www.iso.org/patents

Any trade name used in this document is information given for the convenience of users and does not constitute an endorsement.

The committee responsible for this document is ISO/TC 27, *Solid mineral fuels*, Subcommittee SC 5, *Methods of analysis*.

This second edition cancels and replaces the first edition (ISO 11722:1999), of which it constitutes a minor revision.

Introduction

The determination of the moisture in the general analysis test sample is required to correct the results of certain analytical determinations, e.g. volatile matter and hydrogen, for the effect of water in the determination and to allow all determinations to be corrected to dry basis.

Since hard coal is hygroscopic, its moisture will vary with change of humidity of the atmosphere and the moisture in the general analysis test sample should therefore be determined whenever portions are weighed out for other analytical determinations. If test portions for several analytical determinations are weighed out at the same time, a single simultaneous moisture determination will suffice to correct those analyses.

Solid mineral fuels — Hard coal — Determination of moisture in the general analysis test sample by drying in nitrogen

1 Scope

This International Standard specifies a method for determining the moisture in the general analysis test sample of hard coal by drying in nitrogen.

2 Normative references

The following documents, in whole or in part, are normatively referenced in this document and are indispensable for its application. For dated references, only the edition cited applies. For undated references, the latest edition of the referenced document (including any amendments) applies.

ISO 1213-2, *Solid mineral fuels — Vocabulary — Part 2: Terms relating to sampling, testing and analysis*

3 Terms and definitions

For the purposes of this document, the terms and definitions given in ISO 1213-2 apply.

4 Principle

A known mass of the coal is heated in a stream of nitrogen at a temperature between 105 °C and 110 °C and maintained at this temperature until it is constant in mass. The moisture content is calculated from the loss in mass of the coal.

5 Reagent

Nitrogen, moisture-free, having an volume fraction of oxygen of less than 30 µl/l.

Commercially available nitrogen with a water content of less than 5 µl/l does not require further drying.

6 Apparatus

6.1 Analytical balance, capable of weighing to the nearest 0,1 mg.

6.2 Oven, capable of being controlled at a temperature of 105 °C to 110 °C and with provision for the nitrogen to pass through it at a flow-rate of approximately 15 times the oven volume per hour and of lowest practical volume, i.e. minimum free space.

NOTE An example of a suitable oven is given in [Annex A](#).

6.3 Weighing dish, shallow, of glass or of corrosion-resistant metal, with well-fitting covers, of such a size that the coal layer does not exceed 0,20 g/cm².

6.4 Cooling vessel, e.g. desiccator, without desiccant, containing a metal plate, preferably of aluminium or copper. The vessel may be provided with a means to pass nitrogen through it during the cooling period.

7 Preparation of the test sample

The coal used for the determination of mass fraction moisture is the general analysis test sample. Ensure that the mass fraction moisture in the sample is in equilibrium with the laboratory atmosphere, exposing it, if necessary, in a thin layer for the minimum time required to achieve equilibrium.

Before commencing the determination, thoroughly mix the equilibrated test sample for at least 1 min, preferably by mechanical means.

8 Procedure

Weigh, on an analytical balance (6.1), a clean, dry, empty weighing dish (6.3) with its cover to the nearest 0,1 mg. Add 1 g ± 0,1 g of the coal sample in an even layer and reweigh. Heat the uncovered dish in the oven (6.2) at 105 °C to 110 °C for at least 60 min while passing nitrogen through at approximately 15 times the oven volume per hour. Do not open the oven door during the drying period.

When the drying period is complete, remove the dish with the dried sample from the oven and replace the cover immediately. If the size of the oven allows this, replace the cover while the dish is still in the oven. Allow the dish to cool on a thick metal plate for 10 min. At the end of the 10 min cooling period, transfer the dish to a cooling vessel (6.4) and allow to cool to room temperature. As soon as room temperature is reached, reweigh to the nearest 0,1 mg.

NOTE If a cooling vessel with nitrogen flow is used, the dish can be transferred directly without cooling on a metal plate.

If there is any doubt that drying is not complete, reheat at 105 °C to 110 °C for further 30 min period until any change in mass does not exceed 1 mg.

9 Expression of results

The mass fraction of moisture in the hard coal as analysed, w_M , in percent, is given by the following formula:

$$w_M = \frac{m_2 - m_3}{m_2 - m_1} \times 100$$

where

m_1 is the mass, in grams, of empty dish plus cover;

m_2 is the mass, in grams, of dish plus cover plus coal before heating;

m_3 is the mass, in grams, of dish plus cover plus coal after heating.

Report the result, as the mean of duplicate determinations, to the nearest 0,1 % mass fraction.

10 Precision

10.1 Repeatability limit

The results of duplicate determinations (carried out over a short period of time, but not simultaneously) in the same laboratory, by the same operator, with the same apparatus on two representative portions taken from the same analysis sample, should not differ by more than the values shown in [Table 1](#).

10.2 Reproducibility limit

Since the humidity conditions in different laboratories vary, it is not practical to quote a limiting value for reproducibility.

Table 1 — Precision

Mass fraction of moisture %	Maximum acceptable differences between results Repeatability limit
Less than 5	0,10
Equal to or more than 5	0,15

11 Test report

The test report shall include the following information:

- a) reference to this International Standard, i.e. ISO 11722;
- b) the identification of the sample tested;
- c) the results of the determination.

Annex A (informative)

Example of a suitable oven

An example of a suitable oven for the determination of moisture in the general analysis test sample is given in [Figure A.1](#). It is a so-called “minimum free space oven” which minimizes the amount of nitrogen needed.

However, any other type of oven which meets the criteria given in [6.2](#) will suffice for this International Standard.

Dimensions in millimetres

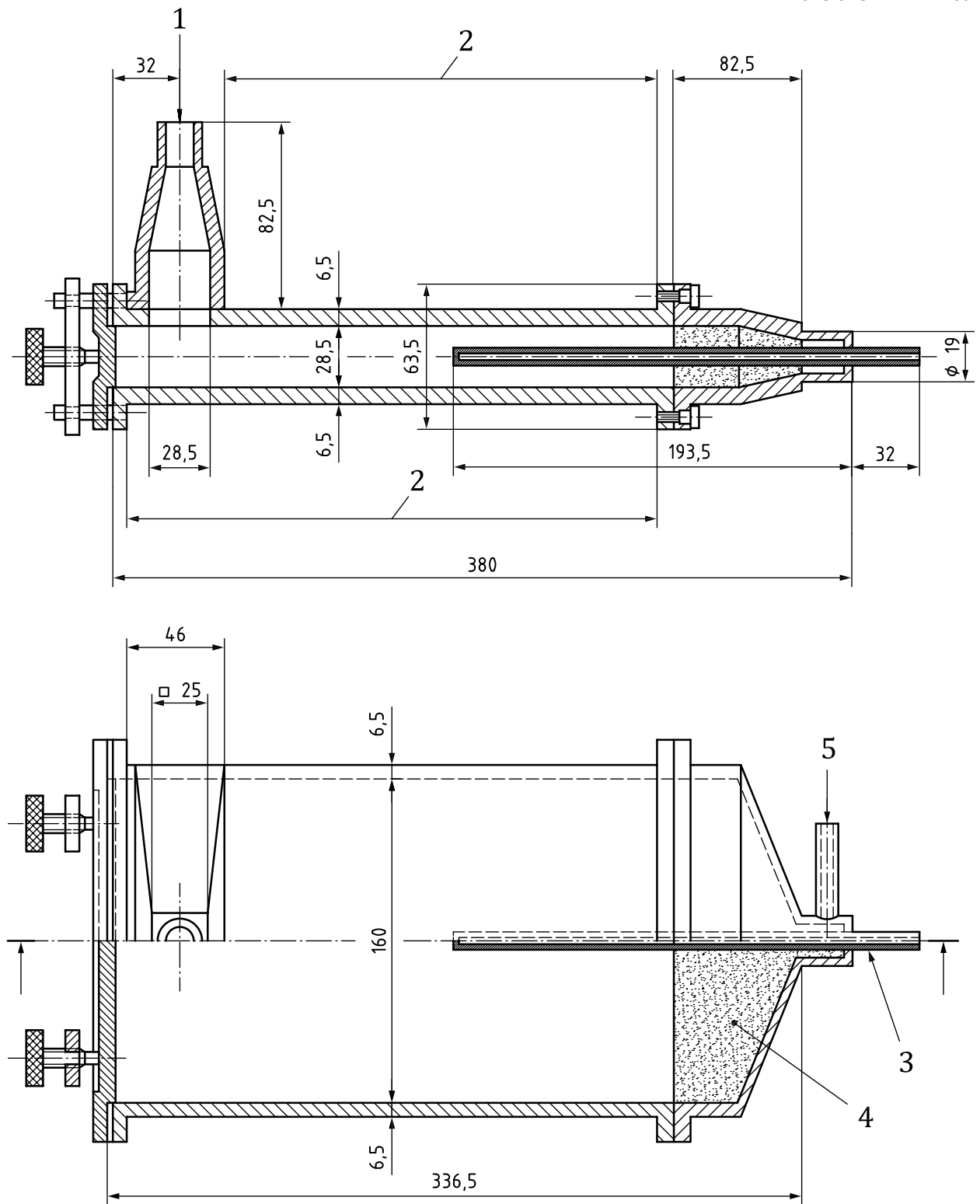

Key

- | | |
|---|-----------------------------------|
| 1 nitrogen outlet | 4 copper gauze mesh openings 0,25 |
| 2 space for heating element | 5 nitrogen inlet |
| 3 tube for temperature-measuring device | |

Figure A.1 — Example of a minimum free space oven

British Standards Institution (BSI)

BSI is the national body responsible for preparing British Standards and other standards-related publications, information and services.

BSI is incorporated by Royal Charter. British Standards and other standardization products are published by BSI Standards Limited.

About us

We bring together business, industry, government, consumers, innovators and others to shape their combined experience and expertise into standards-based solutions.

The knowledge embodied in our standards has been carefully assembled in a dependable format and refined through our open consultation process. Organizations of all sizes and across all sectors choose standards to help them achieve their goals.

Information on standards

We can provide you with the knowledge that your organization needs to succeed. Find out more about British Standards by visiting our website at bsigroup.com/standards or contacting our Customer Services team or Knowledge Centre.

Buying standards

You can buy and download PDF versions of BSI publications, including British and adopted European and international standards, through our website at bsigroup.com/shop, where hard copies can also be purchased.

If you need international and foreign standards from other Standards Development Organizations, hard copies can be ordered from our Customer Services team.

Subscriptions

Our range of subscription services are designed to make using standards easier for you. For further information on our subscription products go to bsigroup.com/subscriptions.

With **British Standards Online (BSOL)** you'll have instant access to over 55,000 British and adopted European and international standards from your desktop. It's available 24/7 and is refreshed daily so you'll always be up to date.

You can keep in touch with standards developments and receive substantial discounts on the purchase price of standards, both in single copy and subscription format, by becoming a **BSI Subscribing Member**.

PLUS is an updating service exclusive to BSI Subscribing Members. You will automatically receive the latest hard copy of your standards when they're revised or replaced.

To find out more about becoming a BSI Subscribing Member and the benefits of membership, please visit bsigroup.com/shop.

With a **Multi-User Network Licence (MUNL)** you are able to host standards publications on your intranet. Licences can cover as few or as many users as you wish. With updates supplied as soon as they're available, you can be sure your documentation is current. For further information, email bsmusales@bsigroup.com.

BSI Group Headquarters

389 Chiswick High Road London W4 4AL UK

Revisions

Our British Standards and other publications are updated by amendment or revision.

We continually improve the quality of our products and services to benefit your business. If you find an inaccuracy or ambiguity within a British Standard or other BSI publication please inform the Knowledge Centre.

Copyright

All the data, software and documentation set out in all British Standards and other BSI publications are the property of and copyrighted by BSI, or some person or entity that owns copyright in the information used (such as the international standardization bodies) and has formally licensed such information to BSI for commercial publication and use. Except as permitted under the Copyright, Designs and Patents Act 1988 no extract may be reproduced, stored in a retrieval system or transmitted in any form or by any means – electronic, photocopying, recording or otherwise – without prior written permission from BSI. Details and advice can be obtained from the Copyright & Licensing Department.

Useful Contacts:

Customer Services

Tel: +44 845 086 9001

Email (orders): orders@bsigroup.com

Email (enquiries): cservices@bsigroup.com

Subscriptions

Tel: +44 845 086 9001

Email: subscriptions@bsigroup.com

Knowledge Centre

Tel: +44 20 8996 7004

Email: knowledgecentre@bsigroup.com

Copyright & Licensing

Tel: +44 20 8996 7070

Email: copyright@bsigroup.com



...making excellence a habit.™