

Anaesthetic and respiratory equipment — Supralaryngeal airways and connectors

ICS 11.040.10

National foreword

This British Standard is the UK implementation of ISO 11712:2009.

The UK participation in its preparation was entrusted to Technical Committee CH/121/5, Lung ventilators, tracheal tubes and related equipment.

A list of organizations represented on this committee can be obtained on request to its secretary.

This publication does not purport to include all the necessary provisions of a contract. Users are responsible for its correct application.

Compliance with a British Standard cannot confer immunity from legal obligations.

This British Standard was published under the authority of the Standards Policy and Strategy Committee on 30 June 2009

© BSI 2009

ISBN 978 0 580 60877 3

Amendments/corrigenda issued since publication

Date	Comments

INTERNATIONAL
STANDARD

ISO
11712

First edition
2009-05-15

**Anaesthetic and respiratory equipment —
Supralaryngeal airways and connectors**

*Matériel d'anesthésie et de réanimation respiratoire — Canules
supralaryngées et raccords*



Reference number
ISO 11712:2009(E)

PDF disclaimer

This PDF file may contain embedded typefaces. In accordance with Adobe's licensing policy, this file may be printed or viewed but shall not be edited unless the typefaces which are embedded are licensed to and installed on the computer performing the editing. In downloading this file, parties accept therein the responsibility of not infringing Adobe's licensing policy. The ISO Central Secretariat accepts no liability in this area.

Adobe is a trademark of Adobe Systems Incorporated.

Details of the software products used to create this PDF file can be found in the General Info relative to the file; the PDF-creation parameters were optimized for printing. Every care has been taken to ensure that the file is suitable for use by ISO member bodies. In the unlikely event that a problem relating to it is found, please inform the Central Secretariat at the address given below.



COPYRIGHT PROTECTED DOCUMENT

© ISO 2009

All rights reserved. Unless otherwise specified, no part of this publication may be reproduced or utilized in any form or by any means, electronic or mechanical, including photocopying and microfilm, without permission in writing from either ISO at the address below or ISO's member body in the country of the requester.

ISO copyright office
Case postale 56 • CH-1211 Geneva 20
Tel. + 41 22 749 01 11
Fax + 41 22 749 09 47
E-mail copyright@iso.org
Web www.iso.org

Published in Switzerland

Contents

Page

Foreword.....	iv
Introduction	v
1 Scope	1
2 Normative references	1
3 Terms and definitions.....	2
4 General requirements.....	3
5 *Requirements.....	4
5.1 Supralaryngeal airways.....	4
5.1.1 *Size designation	4
5.1.2 Materials	4
5.1.3 *Ventilatory opening.....	4
5.1.4 *Safeguards against collapse of the ventilatory pathway	5
5.1.5 *Sealing mechanism	5
5.1.6 *Internal volume	5
5.1.7 Maximum instrument size.....	5
5.2 Supralaryngeal airway connectors	6
6 Requirements for supralaryngeal airways and connectors supplied sterile	6
6.1 Sterility assurance.....	6
6.2 Packaging for supralaryngeal airways and connectors supplied sterile.....	6
7 Cleaning and disinfection or sterilization	6
8 Markings	6
8.1 Use of symbols	6
8.2 Marking of the supralaryngeal airway	6
8.3 Marking on the supralaryngeal airway individual pack	7
9 Accompanying documents.....	7
Annex A (informative) Rationale	10
Annex B (normative) Evaluation and documentation of the clinical performance in human subjects	15
Annex C (normative) Test methods to determine kink resistance.....	17
Annex D (informative) Hazard identification for risk assessment.....	22
Annex E (informative) Guidance on materials and design.....	26
Bibliography	28

Foreword

ISO (the International Organization for Standardization) is a worldwide federation of national standards bodies (ISO member bodies). The work of preparing International Standards is normally carried out through ISO technical committees. Each member body interested in a subject for which a technical committee has been established has the right to be represented on that committee. International organizations, governmental and non-governmental, in liaison with ISO, also take part in the work. ISO collaborates closely with the International Electrotechnical Commission (IEC) on all matters of electrotechnical standardization.

International Standards are drafted in accordance with the rules given in the ISO/IEC Directives, Part 2.

The main task of technical committees is to prepare International Standards. Draft International Standards adopted by the technical committees are circulated to the member bodies for voting. Publication as an International Standard requires approval by at least 75 % of the member bodies casting a vote.

Attention is drawn to the possibility that some of the elements of this document may be the subject of patent rights. ISO shall not be held responsible for identifying any or all such patent rights.

ISO 11712 was prepared by Technical Committee ISO/TC 121, *Anaesthetic and respiratory equipment*, Subcommittee SC 2, *Tracheal tubes and other equipment*.

Introduction

* A **supralaryngeal airway** is a device placed through the mouth, intended to seal the supralaryngeal area to maintain airway **patency** without passing through the vocal cords and to independently facilitate ventilation with or without delivery of anesthesia gases. Devices intended to provide a breathing airway and/or to simultaneously provide a guide for the intubation of **tracheal tubes**, bronchoscopes and suction devices are also included in the scope of this International Standard, as are the connectors inserted into the **machine end** of these devices.

* Examples of **supralaryngeal airway** devices are laryngeal masks, laryngeal tubes, airways and seals, cuffed **oropharyngeal airways**, and pharyngeal airways, and combination airway/esophageal obturators.

The requirements of this International Standard were developed using the hazard identification for risk assessment in Annex D.

The requirements for testing and disclosure apply to devices introduced to the market after the publication of this International Standard.

Throughout this International Standard, terms defined in ISO 4135 or in this International Standard appear in **bold type**.

Throughout this International Standard, text for which a rationale is provided in Annex A is indicated by an asterisk (*).

Anaesthetic and respiratory equipment — Supralaryngeal airways and connectors

1 Scope

1.1 This International Standard provides the essential requirements for the design of supralaryngeal airways and connectors. These devices are intended to open and seal the supralaryngeal area to provide an unobstructed airway in patients during spontaneous, assisted or controlled ventilation.

1.2 This International Standard specifies the dimensions, basic properties and method of size designation of the available types of supralaryngeal airways. Airways devised for specialized applications are not specifically covered, although most may be classified by the sizing and dimensions (or other characteristics) required by this International Standard.

1.3 The following devices are outside the scope of this International Standard: nasal and oropharyngeal airways, anesthetic masks, oro- and naso-tracheal tubes, cricothyrotomy devices, dental appliances, tracheal stents, tracheal tubes, ventilating laryngoscopes, CPAP devices, esophageal obturators, bougies and devices that require surgical placement.

1.4 This International Standard requires dimensional disclosure so the operator will know which auxiliary instruments, such as tracheal tubes and bronchoscopes will be size-compatible.

1.5 Flammability of airways, for example if used with certain flammable anesthetics, electrosurgical units or lasers, is a well-recognized hazard that is outside the scope of this International Standard. See E.1.7.

2 Normative references

The following referenced documents are indispensable for the application of this document. For dated references, only the edition cited applies. For undated references, the latest edition of the referenced document (including any amendments) applies.

ISO 594-1, *Conical fittings with a 6 % (Luer) taper for syringes, needles and certain other medical equipment — Part 1: General requirements*

ISO 4135, *Anaesthetic and respiratory equipment — Vocabulary*

ISO 5356-1, *Anaesthetic and respiratory equipment — Conical connectors — Part 1: Cones and sockets*

ISO 5361:1999, *Anaesthetic and respiratory equipment — Tracheal tubes and connectors*

ISO 7000, *Graphical symbols for use on equipment — Index and synopsis*

ISO 10993-1, *Biological evaluation of medical devices — Part 1: Evaluation and testing within a risk management process*

ISO 11607:2003, *Packaging for terminally sterilized medical devices*

ISO 11134, *Sterilization of health care products — Requirements for validation and routine control — Industrial moist heat sterilization*

ISO 11135:1994, *Medical Devices — Validation and routine control of ethylene oxide sterilization*

ISO 11137-1, *Sterilization of health care products — Radiation — Part 1: Requirements for development, validation and routine control of a sterilization process for medical devices*

ISO 11990, *Optics and optical instruments — Lasers and laser-related equipment — Determination of laser resistance of tracheal tube shafts*

ISO/TR 11991, *Guidance on airway management during laser surgery of upper airway*

ISO 14155-1, *Clinical investigation of medical devices for human subjects — Part 1: General requirements*

ISO 14155-2, *Clinical investigation of medical devices for human subjects — Part 2: Clinical investigation plans*

ISO 14408, *Tracheal tubes designed for laser surgery — Requirements for marking and accompanying information*

3 Terms and definitions

For the purposes of this document, the terms and definitions in ISO 4135 and the following apply.

**3.1
auxiliary ventilatory opening**
secondary opening in the ventilatory pathway intended for passage of ventilatory gases at or near the patient end

**3.2
cuff**
compliant seal permanently attached to the supralaryngeal airway to provide a seal between the tube and the oropharynx

**3.3
external seal**
seal that is positioned outside the patient

EXAMPLE A seal between a face mask and the face.

**3.4
internal seal**
seal that is positioned inside the patient at some point in the respiratory tract

NOTE For **supralaryngeal airways** the **internal seal** is typically located in proximity to the glottic inlet.

**3.5
patency**
openness (lack of obstruction) of the **supralaryngeal airway**

**3.6
patient end**
that end of the **supralaryngeal airway** intended to be inserted into the patient

**3.7
machine end**
that end of the supralaryngeal airway or the supralaryngeal airway connector intended to connect to the breathing system

3.8

pressure drop

pressure differential at a specified flow

3.9

sealing mechanism

that portion of the **device in contact with the patient** that enables isolation of ventilatory gases

3.10

supralaryngeal airway

device placed through the mouth but not through the vocal cords, which is intended to form an **internal seal** in the supralaryngeal area to maintain airway **patency**

3.11

supralaryngeal airway connector

tubular component of an **supralaryngeal airway** intended for connection to a breathing system or ventilation bag

3.12

ventilatory opening

opening in the **supralaryngeal airway** near the patient end and intended to allow passage of gases and/or devices such as a tracheal tube, suction catheter or endoscope

NOTE A supralaryngeal airway can have more than one ventilatory opening.

3.13

ventilatory pathway

part of the **supralaryngeal airway** through which gases are intended to pass

4 General requirements

4.1 This International Standard specifies requirements that are generally applicable to risks associated with **supralaryngeal airways**. An established risk management process shall be applied to the design of the device. See Annex D for an informative list of identified hazards.

4.2 The supralaryngeal airway shall permit ventilation in those head and neck positions, and in those patient positions for which the device is intended.

4.3 The supralaryngeal airway shall permit ventilation when the patient is in the supine position and the head and neck are at neutral positions and at least $\pm 30^\circ$ of:

- a) flexion;
- b) extension;
- c) right and left rotation;
- d) right and left lateral flexion (tilt).

4.4 The supralaryngeal airway shall also permit ventilation in the following positions and in any position intended for use:

- a) Trendelenburg's (head down, 10°);
- b) sitting (45°).

Compliance shall be tested by examination of the mitigations described in a risk assessment and associated verification and validation studies.

NOTE 1 See Annex A and Annex D.

If clinical studies are performed, these studies shall document measurements taken during the conditions for which performance is claimed. The clinical studies shall comply with the requirements of ISO 14155-1, and ISO 14155-2.

NOTE 2 See also Annex B for evaluating and documenting the clinical performance of supralaryngeal airways in human subjects.

4.5 The supralaryngeal airway shall, when transported, stored and used as intended by the manufacturer, minimize safety hazards which could reasonably be foreseen in normal and single-fault condition.

4.6 Where the requirements of this International Standard refer to freedom from unacceptable risk, acceptability or unacceptability of this risk is determined by the manufacturer in accordance with the manufacturer's policy for determining acceptable risk.

4.7 The manufacturer may use type tests different from those detailed within this International Standard, if an equivalent degree of safety is obtained. However, in the event of dispute, the methods specified herein shall be used as the reference methods.

4.8 Many of the test clauses within this International Standard establish acceptance criteria for performance aspects. These acceptance criteria shall always be met. If the manufacturer chooses to specify in the accompanying documents higher performance levels than those specified within this International Standard these manufacturer-specified levels become the acceptance levels and shall also be met.

5 *Requirements

5.1 Supralaryngeal airways

5.1.1 *Size designation

The size of a **supralaryngeal airway** shall be designated using the following convention:

- a) the range of sizes shall be from 0 to 6; the smallest increment permitted is 0,5;
- b) sizes from 0 to 6 shall be designated for the smallest to largest size devices; the transition size from pediatric to adult is size 3.

5.1.2 Materials

5.1.2.1 Supralaryngeal airways, including the sealing mechanism and connector in its ready-for-use state after any preparation for use recommended by the manufacturer, shall satisfy appropriate biological safety testing, as indicated in ISO 10993-1. Initial biocompatibility evaluation tests shall include all materials in the **supralaryngeal airway** and be tested as external communicating, tissue/bone/dentin communicating, < 24 h contact devices. If the proposed contact duration is greater than 24 h, biocompatibility tests shall include those tests for > 24 hr duration.

5.1.2.2 The marking of the **supralaryngeal airway** shall be durable and legible.

NOTE See Annex E.

5.1.3 *Ventilatory opening

An opening intended to allow ventilation shall be provided at or near the patient end of the device. Auxiliary ventilatory openings may be provided to reduce the risk from obstruction.

Compliance shall be determined by inspection.

5.1.4 *Safeguards against collapse of the ventilatory pathway

Means shall be provided to resist collapse of the ventilatory pathway from kinking or compression.

The kink resistance of the **supralaryngeal airway** lumen shall be tested in accordance with Annex C.

The resistance to compression shall be evaluated by examination of the mitigations described in a risk assessment and associated verification and validation studies.

5.1.5 *Sealing mechanism

5.1.5.1 A sealing mechanism shall be integrally attached to the **supralaryngeal airway**.

5.1.5.2 The sealing mechanism shall produce no audible leak under a positive pressure of 10 cm/H₂O for a minimum of 3 s.

Compliance shall be tested by clinical study measurements. **Functional testers** or **patient** simulators shall not be used to validate the performance of the supralaryngeal airway. The clinical studies shall document measurements taken during the conditions for which performance is claimed. The clinical studies shall comply with the requirements of ISO 14155-1 and ISO 14155-2.

NOTE See also Annex B.

5.1.5.3 The sealing mechanism shall not occlude the **ventilatory opening** nor collapse the **ventilatory pathway**.

Compliance shall be tested by a method chosen by the manufacturer based upon an examination of the mitigations described in a risk assessment and associated verification and validation studies.

5.1.5.4 Inflation/deflation system.

If provided, the inflation system shall include an inflating tube, a pilot balloon or other device to indicate inflation or deflation.

NOTE This (these) device(s) may also serve as a pressure-indicating or pressure-limiting device.

5.1.5.5 *The free end of the **inflation tube** shall be either open or sealed with a closure device or inflation valve. If interface with an external inflation device is required, the free end of the inflation tube shall be capable of accepting a male conical fitting with a 6 % (Luer) taper, complying with ISO 594-1.

5.1.5.6 The intentional deflation of the sealing mechanism shall not be prevented by the inflation tube, inflation valve or any closure device acting as a non-return valve.

5.1.6 *Internal volume

The internal volume of the **ventilatory pathway** shall be measured in accordance with the following test method.

Cap one end of the **ventilatory pathway**. Measure the volume of water in millilitres required to fill the ventilatory pathway from the **ventilatory opening** up to and including the 15 mm connector at the machine end of the device.

5.1.7 Maximum instrument size

The maximum size of devices that will easily pass through the **ventilatory pathway** shall be specified by the manufacturer. Devices may include (but are not limited to) tracheal tubes, suction catheters, fiberoptic scopes, bougies, etc. The instrument may be lubricated with water or water-soluble lubricant to assist the passage [see 9 e)].

Compliance shall be determined by functional testing.

5.2 Supralaryngeal airway connectors

5.2.1 The **machine end** of a **supralaryngeal airway connector** shall be a male 15 mm conical connector complying with ISO 5356-1. Any transition in the inside diameter shall be smooth to permit an adequate lead-in for smooth passage and removal of an instrument.

5.2.2 The opening at the patient end shall have a plane at $90^\circ \pm 5^\circ$ to the long axis of the **patient end** of the connector.

6 Requirements for supralaryngeal airways and connectors supplied sterile

6.1 Sterility assurance

Supralaryngeal airways with connectors supplied and marked as "STERILE" shall satisfy the requirements of ISO 11134, ISO 11135 or ISO 11137-1, if applicable.

6.2 Packaging for supralaryngeal airways and connectors supplied sterile

Each **supralaryngeal airway** and connector (if supplied) and marked as "STERILE" shall be contained in an individual pack. The pack shall serve as an effective barrier to the penetration of microorganisms and particulate material, in accordance with ISO 11607. The pack shall permit the aseptic extraction of the contents and shall not be capable of reclosure without clearly revealing that the pack has been opened.

7 Cleaning and disinfection or sterilization

Supralaryngeal airways and connectors not intended for single use shall be designed to be suitable for cleaning and disinfection or sterilization by methods described in the accompanying documents.

NOTE See Annex E.

8 Markings

8.1 Use of symbols

Symbols shall be accompanied by equivalent text in United States English on devices intended for use in the United States. The requirements of 8.2 may be met by the appropriate symbols as given in ISO 7000.

8.2 Marking of the supralaryngeal airway

8.2.1 Marking of the **supralaryngeal airways** shall include the following:

- a) the name and/or trademark of the manufacturer or supplier;
- b) the designated size in bold type in accordance with 5.1.1; devices that encompass a range of sizes shall be marked with the corresponding range;
- c) the words "SINGLE USE" or equivalent, for **supralaryngeal airways** not intended for re-use;
- d) *normal depth of insertion marking(s) or indicator(s) visible around the shaft of the **supralaryngeal airway** corresponding to patient's incisors or gums to show the typical range of intended depth of insertion;

NOTE Depth of insertion range marking(s) need not be continuously circumferential around the tube.

- e) depth mark(s), if provided, in centimeters measured from the **patient end** of the **ventilatory opening**.

8.2.2 Marking materials shall:

- a) be nontoxic and tissue-compatible;
- b) resist deterioration by anaesthetic agents;
- c) remain legible during use.

8.3 Marking on the supralaryngeal airway individual pack

The following shall be marked on, or be visible through, the **supralaryngeal airway** individual pack:

- a) a description of contents;
- b) the designated size in accordance with 5.1.1; devices that encompass a range of sizes shall be marked with the corresponding range;
- c) the name and/or trademark of the manufacturer and/or supplier;
- d) the batch number or serial number;
- e) the word "STERILE" if appropriate;

NOTE It is recommended that the method of sterilization be given.

- f) for **supralaryngeal airways** not intended for re-use, the words "SINGLE USE" or equivalent;
- g) instructions for action in the event of damage to the sterile packaging for **supralaryngeal airways** supplied sterile;
- h) expiration date, if appropriate.

9 Accompanying documents

The manufacturer shall disclose the following information in the accompanying documents:

- a) instructions for use, including proper insertion and stabilization techniques for the **supralaryngeal airway**;
- b) instructions for use with other instruments such as **tracheal tubes** or bronchoscopes, where indicated;
- c) the internal volume in millilitres as tested in 5.1.6;
- d) the **pressure drop** in centimetres H₂O at a specified test flow, as determined in Annex C;
- e) the maximum device size, as tested in 5.1.7, for tracheal tubes and fiberoptic bronchoscopes;
- f) whether the device is intended for single use or is re-usable;
- g) instructions for action in the event of damage to the packaging for **supralaryngeal airways** supplied sterile;
- h) minimum interdental gap, in millimeters, required for insertion;
- i) a diagram of the device, showing the major components, including the nominal length of the internal pathway(s), in centimeters from the **machine end of the connector** to the **ventilatory opening** and any other working channels within the device;

- j) a diagram showing the intended position of the **supralaryngeal airway** with the anatomic landmarks listed in Figure 1; other landmarks shall be included when identified as mitigations in a risk assessment and associated verification and validation studies;
- k) a warning if the **supralaryngeal airway** does not protect the trachea or lungs from the risk of aspiration;
- l) a precaution that the patency of the **supralaryngeal airway** should be reconfirmed after any change in the patient's head or neck position;
- m) a statement that a summary of the methods, materials, data and results of clinical studies that validate the requirements of this International Standard is available on request, if applicable;
- n) a warning that the **supralaryngeal airway** contains natural rubber latex, if applicable;
- o) a statement that use of a bite block is recommended, unless a bite block is an integral part of the supralaryngeal airway;
- p) a warning that the **cuff** volume or pressure may change in the presence of nitrous oxide, oxygen or other medical gases, if applicable;
- q) a warning that **supralaryngeal airways** may be flammable in the presence of lasers and electrocautery equipment;
- r) information regarding precautions necessary for the disposal of biohazardous materials;
- s) the manufacturer shall disclose appropriate storage conditions;
- t) instructions for cleaning and disinfection or sterilization, and the maximum number of reuses, if the device is re-usable.

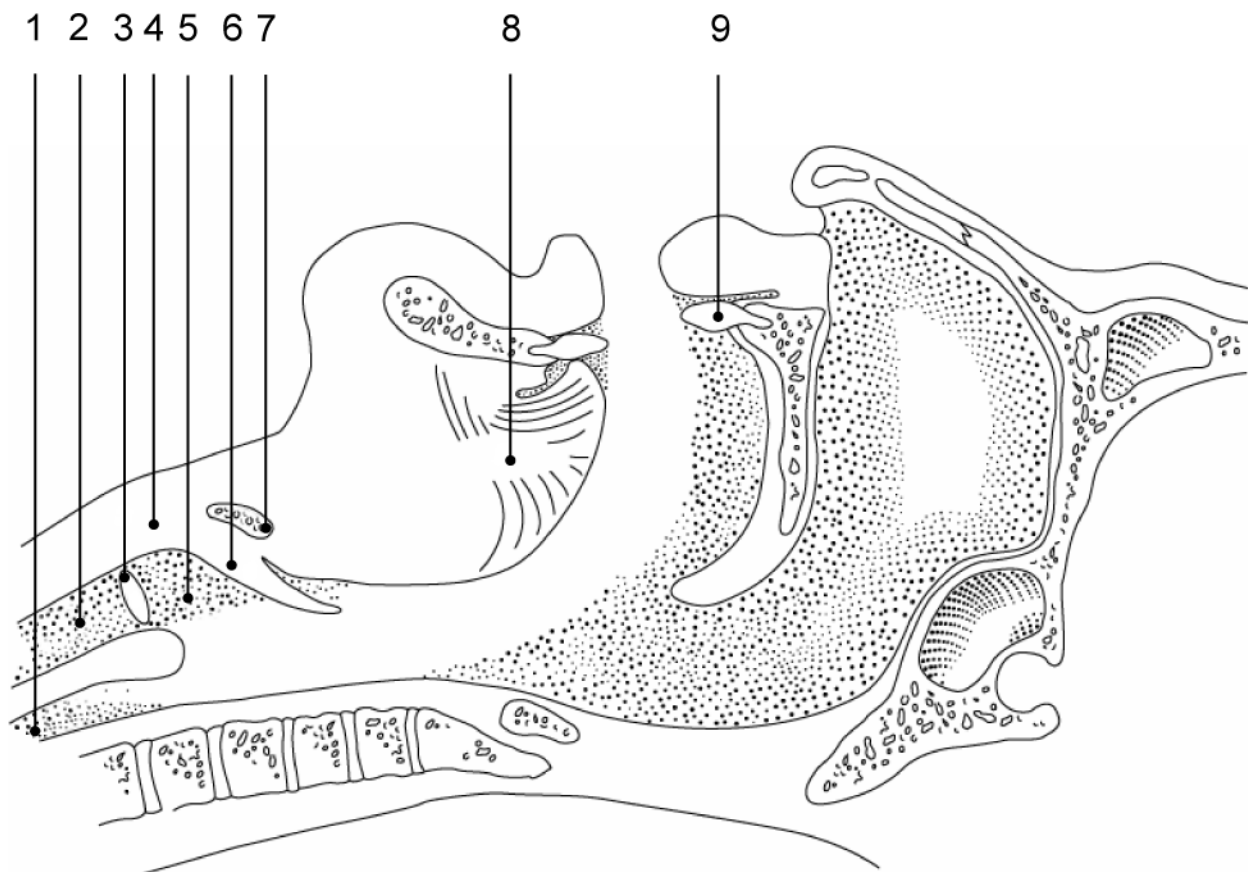

Key

Anatomic landmarks

- 1 esophagus
- 2 trachea
- 3 vocal cords/folds
- 4 thyroid cartilage
- 5 laryngeal inlet
- 6 epiglottis
- 7 hyoid bone
- 8 tongue
- 9 incisors

Supralaryngeal airway components to be labelled (but not shown here):

- 10 sealing mechanism
- 11 ventilatory opening
- 12 normal depth of insertion marks

NOTE This diagram is for use in the depiction of the intended position of the supralaryngeal airway in relation to anatomic landmarks.

Figure 1 — Diagram of the airway

Annex A (informative)

Rationale

NOTE The subclause numbering in this annex corresponds that in the main body of the text and hence does not follow a logical numerical order.

A.1 Introduction

Supralaryngeal airways represent a class of medical devices that are designed to facilitate spontaneous, assisted or controlled ventilation. **Supralaryngeal airways** differ from other airway devices, such as oropharyngeal airways and tracheal tubes, in that they do not require a facial seal or tracheal insertion for ventilation. Since several devices already exist that fulfill the criteria for a **supralaryngeal airway**, and because these devices differ significantly in their conceptual and functional design, the subcommittee, SC 2, has made every effort to define the essential requirements for the design of **supralaryngeal airways**. Thus, the work of this subcommittee was to provide a general framework for classifying the currently available airway devices and provides a useful platform for the design and development of future **supralaryngeal airways** without being design restrictive or impeding development.

The devices covered by this International Standard:

- allow spontaneous ventilation;
- are capable of maintaining airway patency when the airway connector is open to ambient atmosphere;
- facilitate positive pressure ventilation while minimizing escape of respirable gases to ambient atmosphere;
- provide a supralaryngeal airway connector on the machine end of the device to enable connection to a breathing system;
- do not require an external seal;
- do not require surgical placement;
- are not designed to enter the trachea.

Subcommittee SC 2 established that there are at least five different classifications of **supralaryngeal airway** designs as follows.

- a) Cuffed oropharyngeal airway, where the ventilatory opening is located at the base of the tongue and a sealing surface is located in the oropharynx.
- b) Laryngeal masks, where the ventilatory opening is surrounded by the cuff, which forms a seal with the periglottic tissues. The ventilatory opening and the cuff seal usually represent the most distal portion of the device.
- c) Pharyngeal or pharyngeal-esophageal tube, where a cuff surrounds the ventilatory tube in a circumferential fashion and is located proximal to the ventilatory opening. This design compartmentalizes the pharynx, with the cuff serving as a sealing divider between the proximal and distal pharyngeal compartments, and the ventilatory opening(s) are located in the distal pharyngeal compartment. The laryngeal tube is an example of this airway type.
- d) Pharyngeal airway liner, which is represented by the streamlined liner pharyngeal airway (SLIPA). This is a shell-like device that, upon insertion, expands the soft tissues of the neck. The tension of the elastic

neck soft tissues that surround the device provides the sealing mechanism. The ventilatory opening is located within the shell in the periglottic area.

- e) Device with a soft, gel-like, non-inflatable cuff and widened, concaved buccal cavity stabiliser. The sealing mechanism is created by the soft non-inflatable cuff accurately mirroring the anatomy of the laryngeal inlet to create an impression fit, without the need for cuff inflation.

A.1.3 Devices outside the scope of supralaryngeal airways

While it was possible to include certain design variations of nasal supralaryngeal airways, the subcommittee excluded them from the scope of this International Standard because no commercial device was known to be available and nasal insertion was thought to carry an inherently higher risk for the patient.

A.1.5 Identification of hazards for risk assessment

Subcommittee SC 2 compiled a list of known hazards and risks associated with the use of **supralaryngeal airways** based on adverse event reports and known incidents reported in clinical literature. The following potential risks to patients were identified by the task group during the development of this International Standard:

- mechanical trauma to tissue surrounding the **cuff**, neurovascular trauma or tissue ischemia;
- inadequate ventilation/hypoxia;
- risk of aspiration or regurgitation;
- toxicity;
- damage to dental work;
- bleeding;
- cross contamination.

Other risks are more fully described in Annex D. A manufacturer may identify additional patient risks during the development of a particular **supralaryngeal airway**.

A great number of these risks are associated with improper sizing and positioning of the commercial devices, which this specification attempts to clarify. For example, the relationship between the sealing mechanism and oropharyngeal dimensions, materials and wall thickness of the device are some of the factors that influence the intracuff pressure required to provide a supralaryngeal seal when the device is in position. Excessive pressure on the oropharyngeal tissues wall may obstruct capillary blood flow or injure nerves.

Likewise, occlusion of the **ventilatory opening** may also occur in certain **supralaryngeal airway** designs because of the device's proximity to the epiglottis. In order to address this safety concern, this International Standard identifies a requirement for means to prevent occlusion of the **ventilatory opening** by soft tissue if the device does not sit in the glottic inlet in its intended position.

WARNING: Anatomical variations, conditions of use, size of the supralaryngeal airway cuff or other factors may result in the selection of a supralaryngeal airway size either too large or too small for a given patient. The necessity for expert clinical judgment in selecting the size of a supralaryngeal airway remains.

A.4.1 General requirements

The head and neck positions and patient positions required for testing are representative of the most typical positions encountered in clinical practice. Other positions that are potentially useful, such as lateral and prone, were excluded because of the additional complexity and patient risk associated with these requirements.

A.5 Requirements

Requirements in Clause 5 of this International Standard were built on mitigation to the identified risks in Annex D.

A.5.1.1 Size designation

Currently, there is little information available regarding the correlation of patient weight, height or posterior interlaminar distance of the thyroid cartilage to size selection. Moreover, there are significant anatomical variations among the patients and major design differences between currently available **supralaryngeal airways**. Therefore, subcommittee SC 2 decided to leave decisions about the optimal size selection method to the manufacturers of individual devices. However, the subcommittee did recommend that manufacturers use a uniform nomenclature for size designation, define the optimal placement of the device in relation to airway structures, and provide clearly defined markings near the machine end of the device, which will indicate to the operator whether the device is in its intended position. This information, along with the clinical information obtained from each patient, will allow the operator to make decisions regarding the optimal size selection for each individual patient.

A.5.1.3 Ventilatory opening

Subcommittee SC 2 deliberated over various definitions for the ventilatory opening, many of which were considered to be design restrictive. It was agreed the **ventilatory opening** is typically located in the area of the glottic inlet.

A.5.1.4 Safeguards against collapse of the ventilatory pathway

The subcommittee recognized that different methods may be used by a manufacturer to validate **supralaryngeal airway design**. These methods may include (but not be limited to) engineering analysis, bench testing, animal studies, cadaver studies or results of human clinical studies.

Unlike **tracheal tubes**, which can be tested using functional testers and patient simulators, some **supralaryngeal airway designs may** only be validated *in vivo* in humans. The great variability of the human airway presents challenges to the safe design of these devices.

The subcommittee is aware that **supralaryngeal airways** may be used in positions other than supine. Trendelenburg's, reverse Trendelenburg's and prone positions should also be tested if the device is intended to be used in these positions.

Resistance to kinking is a physical property that can be measured using the proposed test method for **patency** of the airway. The objective of the test template is to bend the **supralaryngeal airway** into a realistic minimum radius and arc, corresponding to the shape they may be forced into in a hyperflexed position for an extended period of time during use. The template radius and arc dimensions are partly derived from the data published in ISO 11135 and Reference [7] where the distance from the dome of the hard palate to the free end of the epiglottis was measured on MRI views of 50 adult patients with the head in neutral position.

Pressure drop disclosures provide information on the degree of occlusion caused by kinking. The design of the test apparatus is based on the length dimensions of standard **oropharyngeal airways** and clinically available **supralaryngeal airways**.

A.5.1.5.3 The sealing mechanism shall not occlude the ventilatory opening. Technical Committee TC 121 agreed a single test method may not be applicable to all supralaryngeal airways due to the broad variation in designs. The tracheal tube standard cuff herniation test method described in Annex C of ISO 5361:1999 may serve as a useful guide for the development of supralaryngeal airway test method(s). The committee also recognised that other mechanisms may contribute to occlusion of the ventilatory opening. These may include, but are not limited to, in-folding, over-folding, or back-folding, caused by tilting or rotation during insertion or manipulation.



Figure A.1 — An example of in-folding



Figure A.2 — An example of over-folding



Figure A.3 — An example of back-folding

A.5.1.6 Internal volume

Different **supralaryngeal airway** devices have different designs at the patient end. Accordingly, it is incumbent on the manufacturer to assess the interface of ventilatory opening(s) at the patient end of the device with the laryngeal/pharyngeal anatomy and determine the appropriate endpoint of the ventilation pathway for the purpose of internal volume determination. For example, for the Classic LMA, the endpoint of the ventilation pathway could be defined as the point where the aperture bars are located.

A.8.2.1 d) normal depth of insertion range markings

There is no consensus on the optimum style and positioning of depth markings and whether they should differ with size of tube. However, the task group agrees that a **machine end** marking on the tube is required to indicate to the operator the correct placement of the **supralaryngeal airway**.

Subcommittee SC 2 agreed that the normal depth of insertion range markings would be at the machine end of the ventilatory tube. There may be two markings indicating the typical minimum and maximum recommended depths of insertion. The machine end marking will indicate the maximum depth for device insertion, and the patient end marking will indicate the minimum depth. The distance between the machine end and patient end marking will indicate the range of normal insertion depth in relation to the incisors/alveolar ridge and will allow for anatomical differences among patients. The normal depth of insertion range will provide clinicians with useful information and allow them to integrate this information into their clinical management.

Subcommittee SC 2 considered other methods of marking, namely depth marks on the shaft of the airway, but did not require their use due to the wide range of devices and patient anatomical variability.

Normal depth of insertion range markings need not be continuously circumferential around the tube as long as the marks are visible to the operator.

A.9 j)

The subcommittee recognised that the minimum set of anatomic landmarks shown in Figure 1 may be insufficient to describe the optimal positioning of certain supralaryngeal airway designs. Identification of additional landmarks, such as arytenoids cartilage, velliculae and innervation (identified in Figure D.1) may be required when the risk assessment identifies a risk of malpositioning which may lead to injury.

Annex B (normative)

Evaluation and documentation of the clinical performance in human subjects

B.1 General

This annex provides guidelines to evaluate and document the clinical performance of **supralaryngeal airways** when studied in human subjects. The methods described in this annex are applicable to all **supralaryngeal airway** design alternatives whenever human testing is required. It is not intended to prescribe medical practice, proper safety procedures, or institutional review board (IRB) or ethics committee (EC) processes.

NOTE These guidelines apply when 4.1 or 5.1.5.2 require clinical trials.

B.2 Methods, testing on patients

B.2.1 In a clinical environment, the primary responsibility is patient care.

B.2.2 Study population

a) Number and source of subjects

The study should include a sufficient number of subjects in order to attain the statistical significance necessary to demonstrate adequate positive pressure ventilation or spontaneous breathing in patient size range intended for use of the device.

b) Characteristics of the study population

For each device size tested, the subjects should vary in their physical characteristics to the greatest extent possible.

B.2.3 Subject inclusion/exclusion criteria

The study protocol should define the inclusion/exclusion criteria.

B.2.4 Criteria for study termination

Study protocol should define circumstances and/or subject response to the procedure that becomes grounds for study termination.

EXAMPLE The subject is discovered to meet one of the pre-defined exclusion criteria.

B.2.5 Characteristics of the study protocol

The device should continue to perform its intended use under the conditions of neck extension, neck flexion, head rotation and differing patient body positions (Trendelenburg's, sitting, lateral).

B.2.6 Resistance to obstruction of the supralaryngeal airway's ventilatory pathway

This can be demonstrated by one or more of the following:

- a) positive inspiratory pressures necessary to generate adequate ventilation volumes;
- b) measuring changes in end-tidal carbon dioxide concentrations, SpO₂, blood gas concentrations during use;

- c) identifying abnormal capnographic waveforms that indicate airway obstruction;
- d) measuring esophageal pressure measurements in spontaneously breathing patients;
- e) identifying airway response to the presence of the airway during anesthesia (e.g. coughing, bucking);
- f) noting the type, duration and frequency of interventions and airway manipulations (e.g. jaw lift, chin lift, head rotation) required to maintain a patent airway;
- g) noting ease of use, physiological tolerance and complications (e.g. aspiration, regurgitation, laryngospasm, hypoxia).

B.2.7 The sealing mechanism

This shall be effective under conditions of positive pressure ventilation as demonstrated by no audible leak at an inspiratory pressure of 10 cmH₂O held for 3 s.

NOTE With mechanically controlled ventilation this can be achieved by setting the inspiratory pause so that this pressure is held for a minimum of 3 s. With manually controlled ventilation, this can be achieved by setting the APL valve to 10 cmH₂O and keeping the bag partially compressed for 3 s.

An audible leak shall be identified by listening within 15 cm of the patient's mouth or by auscultating over the anterior aspect of the patient's neck.

Annex C (normative)

Test methods to determine kink resistance

C.1 Principle

Resistance to kinking of **supralaryngeal airways** shall be measured as the **pressure drop** of a pre-defined flow rate while bending the airway to a pre-defined minimum of radius of curvature. Test flow rates and minimum radius of curvatures shall vary in accordance with **supralaryngeal airway** size designation.

C.2 Apparatus

C.2.1 Minimum radius of curvature apparatus

Select the minimum radius template shown in Figure C.1 according to the size marking of the **supralaryngeal airway** as defined in Table C.1.

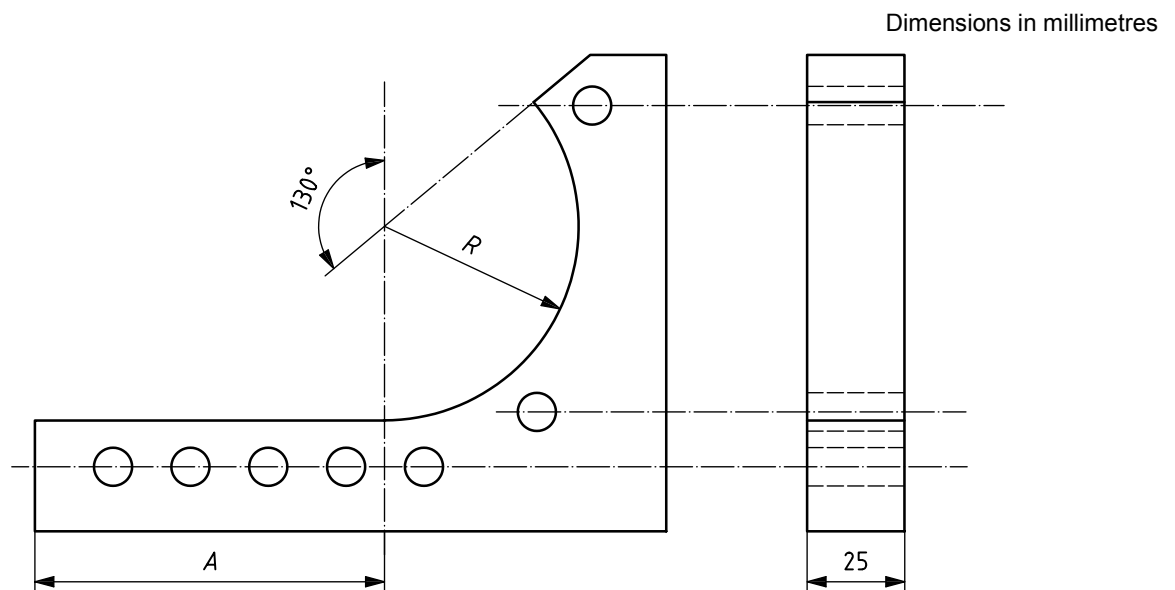

Figure C.1 — Minimum radius of curvature template

Table C.1 — Dimensions of minimum radius template

SLA Size range	Minimum Radius, R (mm)	Straight Length, A (mm)
≥ 3	50	$\cong 90$
$\geq 2\frac{1}{2} + < 3$	40	$\cong 80$
$\geq 1\frac{1}{2} + < 2,5$	30	$\cong 70$
≥ 0	25	$\cong 50$

C.2.2 Measurement of pressure drop apparatus

Assemble an apparatus as shown in Figure C.4 consisting of a source of air, gas flow valve, gas flow meter, differential gas pressure gauge and 15 mm female conical connector, all assembled in series. One port of the differential gas pressure gauge shall be open to atmospheric pressure. For recording purposes, the use of electronic measuring devices is recommended.

C.3 Procedure

C.3.1 Securing and conditioning the supralaryngeal airway to the minimum radius of curvature apparatus

C.3.1.1 If provided, inflate the **sealing mechanism** to the recommended inflation volume.

C.3.1.2 Place the **patient end** of the device against the flat surface of the template in a position where the arrow mark on the template coincides with the recommended depth of insertion relative to the tip of the epiglottis.

C.3.1.3 With the **patient end** in this position tighten the **patient end** of the device against the template using nylon cable strips or equivalent.

C.3.1.4 Bend the airway tube against the curved surface of the template and tighten it to the template at the end of the curvature. Final assembly is as shown, by way of examples of various **supralaryngeal airway** designs, in Figures C.2 and C.3.

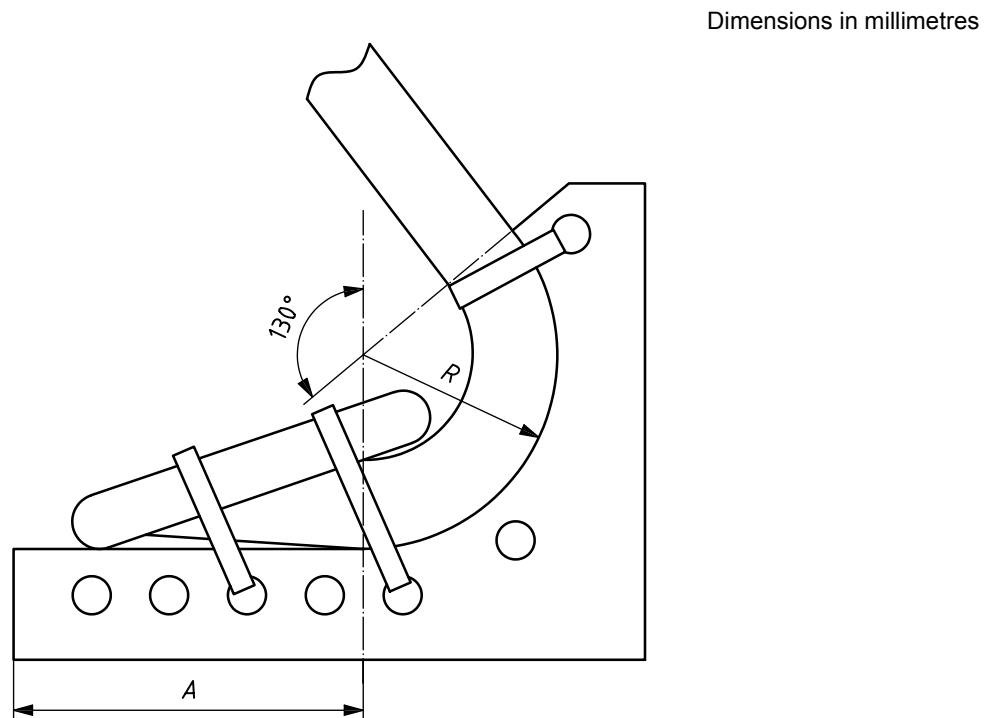

Figure C.2 — Example of strapping a laryngeal mask airway-type supralaryngeal airway to the template

Dimensions in millimetres

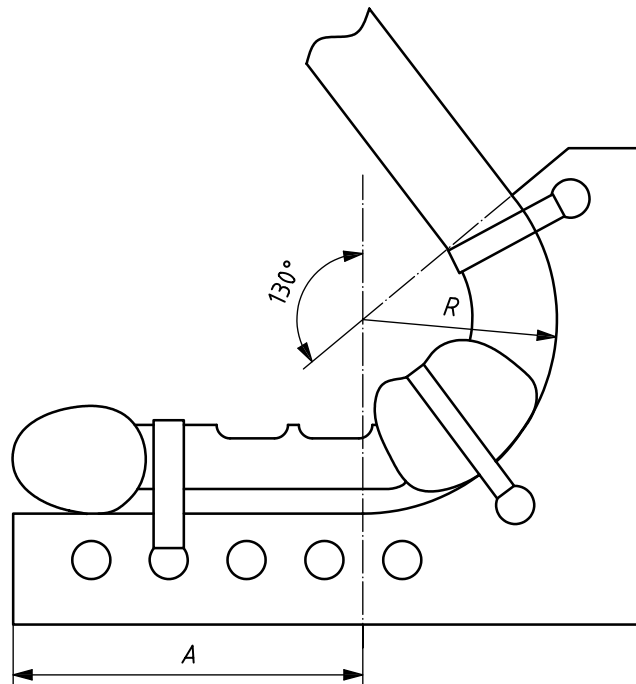

Figure C.3 — Example of strapping a laryngeal tube-type supralaryngeal airway to the template

C.3.1.5 Place the template with the **supralaryngeal airway** in an environmental chamber at $(40 \pm 1)^\circ\text{C}$, $> 90\%$ Relative Humidity for at least 4 h.

C.3.2 Measurement of pressure drop

C.3.2.1 Remove the template with the device from the environmental chamber and measure the **pressure drop** through the **supralaryngeal airway** without removing it from the template.

C.3.2.2 Using the apparatus described in C.2.2, connect the supralaryngeal connector to the apparatus connector and introduce air at a test flow, as specified in Table C.2, through the device.

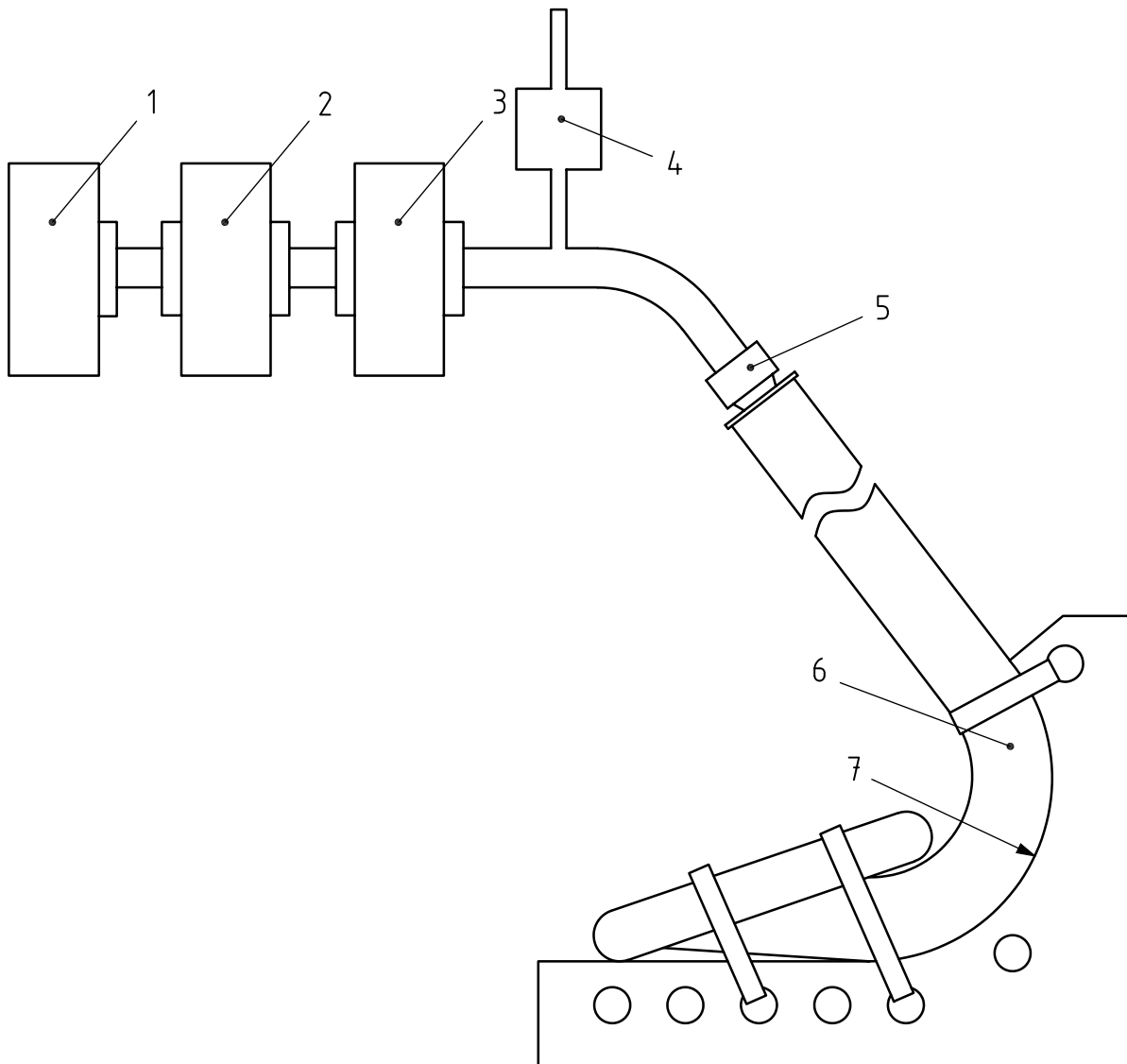

Key

- 1 air source
- 2 flow valve
- 3 flow meter
- 4 pressure gauge
- 5 15 mm female conical connector
- 6 supralaryngeal airway
- 7 minimum radius of curvature apparatus

NOTE For illustration purposes, a laryngeal mask airway-type supralaryngeal airway is depicted.

Figure C.4 — Example of pressure drop apparatus

Table C.2 — Test flow rate

Intended use ideal body weight	Test flow (l/min)
< 10 Kg	15
10 to 30 Kg	30
> 30 Kg	60

C.3.2.3 Determine the **pressure drop** at the flow specified in Table C.2, within 5 s of initiating flow through the **supralaryngeal airway**. The temperature of the gas shall be 23 ± 2 °C.

C.3.2.4 Disconnect and remove the **supralaryngeal airway** and determine the **pressure drop** at the same flow. Subtract this value from that obtained in C.3.2.3. This is the **pressure drop** attributable to the **supralaryngeal airway**.

C.3.2.5 If **auxiliary ventilatory openings** are provided, repeat steps C.3.2.1 to C.3.2.4 for each opening after preconditioning the **supralaryngeal airway** when assembled with the test apparatus specified in C.3.1.

C.4 Expression of results

C.4.1 Express the nominal maximum pressure drop in centimetres H₂O measured through the ventilatory opening and, if provided, the auxiliary ventilatory opening with the primary ventilatory opening occluded.

C.4.2 Check that the pressure drop does not exceed the pressure drop disclosed by the manufacturer in the accompanying literature.

Annex D (informative)

Hazard identification for risk assessment

NOTE This list is not intended to be comprehensive for all devices within the scope of this International Standard, but it provides guidance for risk assessment. Not all hazards will apply to each type of **supralaryngeal airway** device.

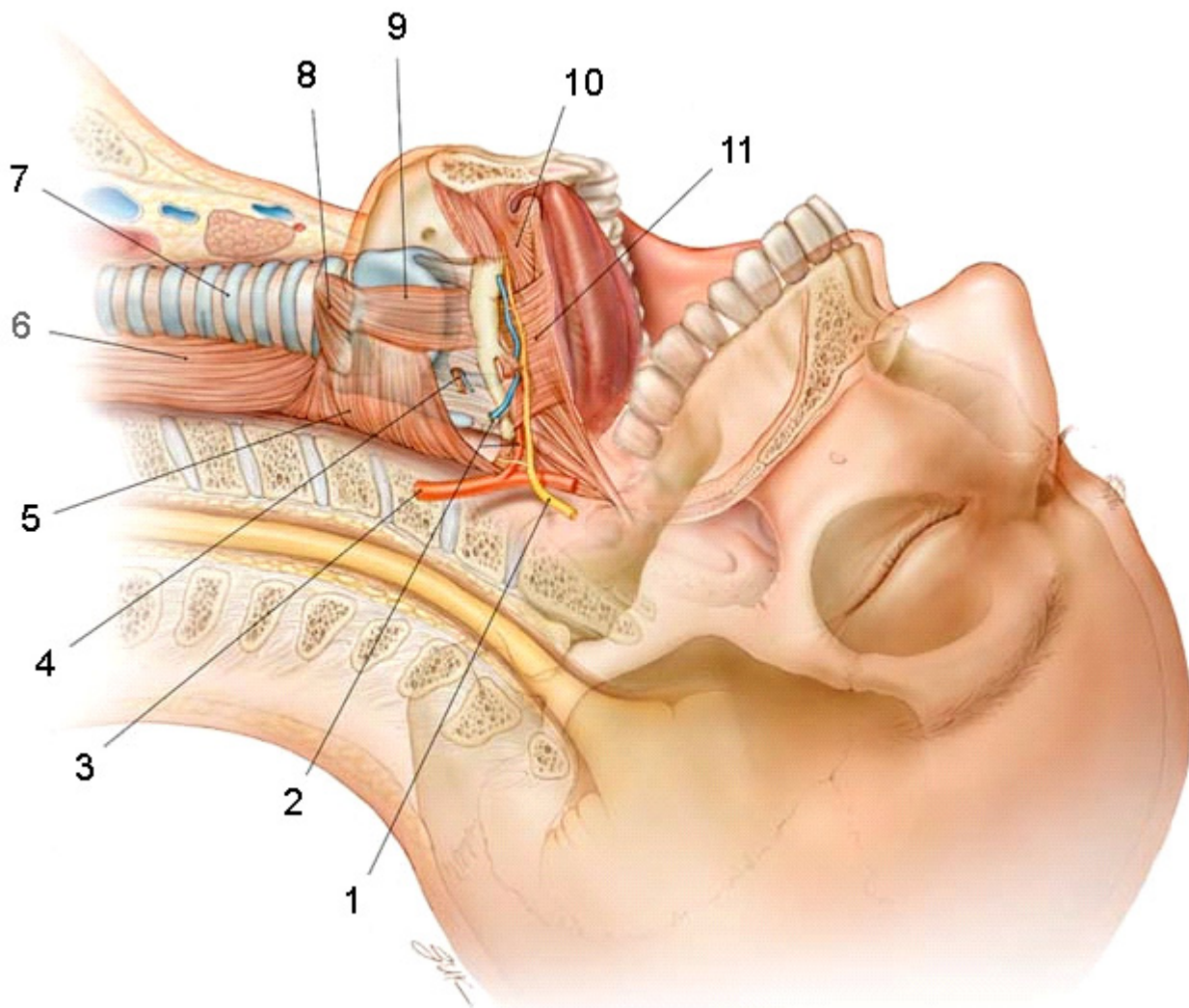

Key

1	hypoglossal n.	7	trachea
2	lingual v. and a.	8	cricothyroid m.
3	external carotid a.	9	thyroid m.
4	superior laryngeal n., a., v.	10	genioglossus m.
5	inferior pharyngeal constrictor	11	hyoglossus m.
6	esophagus		

Figure D.1

D.1 Potential hazards associated with the use of supralaryngeal airways

- a) Trauma (mechanical or neurovascular trauma related to insertion or removal of the **supralaryngeal airway**) to surrounding tissue causing:
- 1) soreness, minor abrasions;
 - 2) haematoma;
 - 3) epiglottic entrapment or inflammation;
 - 4) parotid or salivary gland swelling and inflammation;
 - 5) arytenoid dislocation;
 - 6) upper esophageal sphincter injury;
 - 7) tissue damage, edema;
 - 8) severe or prolonged sore throat;
 - 9) neuropathy;
 - 10) spinal cord damage;
 - 11) paralysis;
 - 12) vocal cord damage;
 - 13) dental damage;
 - 14) bleeding;
 - 15) infection;
 - 16) arytenoid dislocation.
- b) Inadequate ventilation (hypoxia, hypercarbia) due to:
- 1) leakage of respiratory gases;
 - 2) inability to remove device;
 - 3) obstruction from translateral force (torque);
 - 4) bronchospasm, laryngospasm, stridor, hiccup, coughing, breath-holding;
 - 5) pulmonary edema – negative pressure;
 - 6) rebreathing;
 - 7) inadequate spontaneous ventilation;
 - 8) obstruction;
 - 9) increased intrathoracic pressure.

- c) Aspiration or regurgitation due to:
 - 1) inadequate seal;
 - 2) gastric insufflation;
 - 3) inability to evacuate gastric contents;
 - 4) airway obstruction (swelling);
 - 5) airway obstruction (debris).
- d) Toxicity:
 - 1) allergy;
 - i) latex.
- e) Pollution:
 - 1) leakage of ventilatory gas.

D.2 Potential device hazards

- a) Failure or loss of the seal caused by:
 - 1) misplacement;
 - 2) malposition of the head;
 - 3) reposition of the patient;
 - 4) loss of seal pressure;
 - 5) incorrect size;
 - 6) fluid in the ventilatory outlet;
 - 7) material failure of the connector;
 - 8) re-use failures (exceeds re-use cycles);
 - 9) cuff degradation;
 - 10) inflation valve failure;
 - 11) hole, rip, tear in airway shaft or seal.
- b) Loss of **patency** caused by:
 - 1) malposition of the head;
 - 2) debris or fluid in the lumen;
 - 3) seal overinflation;
 - 4) kinking;
 - 5) kiting;
 - 6) fracture of the shaft of the airway.

- c) Seal overinflation caused by:
 - 1) inadequate instructions for use;
 - 2) diffusion of nitrous oxide;
 - 3) malposition of the airway;
 - 4) failure of the **inflation tube** or valve.
- d) Seal underinflation caused by:
 - 1) placement too low relative to laryngeal inlet;
 - 2) undetected leak;
 - 3) leak of gases into environment;
 - 4) **sealing surface** twisted or folded;
 - 5) failure of the **inflation tube** or valve;
 - 6) excessive resistance;
 - 7) increased internal volume.
- e) Incorrect size for a specific patient caused by:
 - 1) inadequate disclosure of patient/size requirements to the operator;
 - 2) inadequate packaging.

D.3 Mitigations

- a) Design
- b) Instructions for use
- c) Labelling
- d) Pre-use checks
- e) Education/training
- f) Compatibility testing
- g) Disclosure
- h) Risk assessment

Annex E (informative)

Guidance on materials and design

E.1 Supralaryngeal airway materials

E.1.1 Materials used for the manufacture of **supralaryngeal airways** should have sufficient rigidity to allow the construction of a tube with the thinnest possible wall which, at the same time, maintains the resistance to collapse and kinking, such as with the application of the weight of the breathing system.

When in place, it should be flexible and soft enough to conform to the patient's anatomy without exerting undue pressure on the body tissues.

E.1.2 The marking of **supralaryngeal airways** should be durable and legible.

E.1.3 Unless intended and marked for single use, **supralaryngeal airways** and connectors and marking materials used on **supralaryngeal airways** should be reasonably resistant to deterioration by the methods of cleaning, disinfection and sterilization recommended by the manufacturer. Such tubes should withstand accepted methods of steam sterilization.

The recommended method or methods of sterilization should not produce changes in the materials which will compromise the biological safety of the **supralaryngeal airway** and connector (see 5.2).

E.1.4 **Supralaryngeal airways** and connectors and marking materials used on **supralaryngeal airways** under normal conditions of use should be reasonably resistant to deterioration by clinically used concentrations of anaesthetic vapours and gases.

E.1.5 **Supralaryngeal airways** should be readily detectable by X-ray, either by the nature of the material of which they are made or by the provision of a marker.

E.1.6 The **supralaryngeal airways** should maintain its intended shape when stored in its original packaging in accordance with the manufacturer's instructions.

E.1.7 Flammability of **supralaryngeal airways**, for example if used with certain flammable anaesthetics, electrosurgical units or lasers, is a well-recognised hazard. **Supralaryngeal airways** intended to be laser resistant should conform to the materials, testing, and marking, labelling, and accompanying information requirements in ISO 11990, ISO 11991 and ISO 14408.

E.2 Connectors

E.2.1 **Supralaryngeal airways** connectors should be lightweight but should be of sufficient strength to resist deformation under normal conditions of use.

E.2.2 **Supralaryngeal airways** connectors should be designed to have minimal **internal volume** and to offer minimal resistance to gas flow. The connector lumen should be smooth and free from ridges.

E.2.3 **Supralaryngeal airways connectors** may be provided with lugs, flats or other means to facilitate connection and disconnection, provided that any protrusions are free from sharp edges.

E.2.4 A retaining or latching device may be incorporated in the design to provide added security of attachment of the conical connectors.

Any projections (for example hooks, lugs or studs) should be designed to minimize the risk of catching on surgical dressings or other equipment.

E.3 Other design considerations

Supralaryngeal airways should have smooth outside and inside surfaces. The surface of the sealing mechanism should be smooth. There should be a smooth transition between the outside surface of the ventilatory pathway and the sealing mechanism points of attachment. The **patient end** of the **supralaryngeal airway** and the **ventilatory opening** should be free of sharp edges.

Bibliography

- [1] ISO 5364, *Anaesthetic and respiratory equipment — Oropharyngeal airways*
- [2] ISO 14971, *Medical devices — Application of risk management to medical devices*
- [3] ISO/TS 16628, *Tracheobronchial tubes — Recommendations for size designation and labelling*
- [4] ASTM F2560:2006, *Standard specification for supralaryngeal airways and connectors*
- [5] EN 980, *Symbols for use in the labelling of medical devices*
- [6] EN 1041, *Information supplied by the manufacturer of medical devices*
- [7] AAMI TIR 16, *Process development and performance qualification for ethylene oxide sterilization — Microbiological aspects*
- [8] AAMI TIR 20, *Parametric release for ethylene oxide sterilization*
- [9] ISO 10993-7, *Biological evaluation of medical devices — Part 7: Ethylene oxide sterilization residuals*
- [10] ISO/TS 15843, *Sterilization of health care products — Radiation sterilization — Product families and sampling plans for verification dose experiments and sterilization dose audits, and frequency of sterilization dose audits*
- [11] BRAIN et al., The Intubating laryngeal mask. I: Development of a new device for intubation of trachea, *British Journal of Anaesthesia*, **79**: pp. 699-703, 1997
- [12] RENDELL-BAKER L., Correspondence from Something Old Something New, *Anesthesiology*. **92**(3), p. 913, March 2000

BSI - British Standards Institution

BSI is the independent national body responsible for preparing British Standards. It presents the UK view on standards in Europe and at the international level. It is incorporated by Royal Charter.

Revisions

British Standards are updated by amendment or revision. Users of British Standards should make sure that they possess the latest amendments or editions.

It is the constant aim of BSI to improve the quality of our products and services. We would be grateful if anyone finding an inaccuracy or ambiguity while using this British Standard would inform the Secretary of the technical committee responsible, the identity of which can be found on the inside front cover. Tel: +44 (0)20 8996 9000. Fax: +44 (0)20 8996 7400.

BSI offers members an individual updating service called PLUS which ensures that subscribers automatically receive the latest editions of standards.

Buying standards

Orders for all BSI, international and foreign standards publications should be addressed to Customer Services. Tel: +44 (0)20 8996 9001. Fax: +44 (0)20 8996 7001 Email: orders@bsigroup.com You may also buy directly using a debit/credit card from the BSI Shop on the Website <http://www.bsigroup.com/shop>

In response to orders for international standards, it is BSI policy to supply the BSI implementation of those that have been published as British Standards, unless otherwise requested.

Information on standards

BSI provides a wide range of information on national, European and international standards through its Library and its Technical Help to Exporters Service. Various BSI electronic information services are also available which give details on all its products and services. Contact Information Centre. Tel: +44 (0)20 8996 7111 Fax: +44 (0)20 8996 7048 Email: info@bsigroup.com

Subscribing members of BSI are kept up to date with standards developments and receive substantial discounts on the purchase price of standards. For details of these and other benefits contact Membership Administration. Tel: +44 (0)20 8996 7002 Fax: +44 (0)20 8996 7001 Email: membership@bsigroup.com

Information regarding online access to British Standards via British Standards Online can be found at <http://www.bsigroup.com/BSOL>

Further information about BSI is available on the BSI website at <http://www.bsigroup.com>

Copyright

Copyright subsists in all BSI publications. BSI also holds the copyright, in the UK, of the publications of the international standardization bodies. Except as permitted under the Copyright, Designs and Patents Act 1988 no extract may be reproduced, stored in a retrieval system or transmitted in any form or by any means – electronic, photocopying, recording or otherwise – without prior written permission from BSI.

This does not preclude the free use, in the course of implementing the standard, of necessary details such as symbols, and size, type or grade designations. If these details are to be used for any other purpose than implementation then the prior written permission of BSI must be obtained.

Details and advice can be obtained from the Copyright and Licensing Manager. Tel: +44 (0)20 8996 7070 Email: copyright@bsigroup.com