



BSI Standards Publication

Measurement of radioactivity in the environment — Air: radon-222

Part 4: Integrated measurement method for
determining average activity concentration
using passive sampling and delayed analysis

National foreword

This British Standard is the UK implementation of ISO 11665-4:2012.

The UK participation in its preparation was entrusted to Technical Committee NCE/2, Radiation protection and measurement.

A list of organizations represented on this committee can be obtained on request to its secretary.

This publication does not purport to include all the necessary provisions of a contract. Users are responsible for its correct application.

© The British Standards Institution 2012. Published by BSI Standards Limited 2012

ISBN 978 0 580 63932 6

ICS 13.040.01; 17.240

Compliance with a British Standard cannot confer immunity from legal obligations.

This British Standard was published under the authority of the Standards Policy and Strategy Committee on 31 July 2012.

Amendments issued since publication

Date	Text affected
------	---------------

**Measurement of radioactivity in the
environment — Air: radon-222 —**

Part 4:

**Integrated measurement method
for determining average activity
concentration using passive sampling
and delayed analysis**

Mesurage de la radioactivité dans l'environnement — Air: radon 222 —

*Partie 4: Méthode de mesure intégrée pour la détermination de l'activité
volumique moyenne du radon avec un prélèvement passif et une
analyse en différé*





COPYRIGHT PROTECTED DOCUMENT

© ISO 2012

All rights reserved. Unless otherwise specified, no part of this publication may be reproduced or utilized in any form or by any means, electronic or mechanical, including photocopying and microfilm, without permission in writing from either ISO at the address below or ISO's member body in the country of the requester.

ISO copyright office
Case postale 56 • CH-1211 Geneva 20
Tel. + 41 22 749 01 11
Fax + 41 22 749 09 47
E-mail copyright@iso.org
Web www.iso.org

Published in Switzerland

Contents

Page

Foreword	iv
Introduction	v
1 Scope	1
2 Normative references	1
3 Terms, definitions and symbols	1
3.1 Terms and definitions	1
3.2 Symbols	1
4 Principle	2
5 Equipment	3
6 Sampling	3
6.1 Sampling objective	3
6.2 Sampling characteristics	3
6.3 Sampling conditions	3
7 Detection	4
8 Measurement	4
8.1 Procedure	4
8.2 Influence quantities	4
8.3 Calibration	5
9 Expression of results	5
9.1 Average radon activity concentration	5
9.2 Standard uncertainty	5
9.3 Decision threshold and detection limit	5
9.4 Limits of the confidence interval	5
10 Test report	6
Annex A (normative) Measurement method using a solid-state nuclear track detector (SSNTD)	7
Annex B (normative) Measurement method using an electret detector	12
Annex C (normative) Measurement method using activated charcoal	20
Bibliography	28

Foreword

ISO (the International Organization for Standardization) is a worldwide federation of national standards bodies (ISO member bodies). The work of preparing International Standards is normally carried out through ISO technical committees. Each member body interested in a subject for which a technical committee has been established has the right to be represented on that committee. International organizations, governmental and non-governmental, in liaison with ISO, also take part in the work. ISO collaborates closely with the International Electrotechnical Commission (IEC) on all matters of electrotechnical standardization.

International Standards are drafted in accordance with the rules given in the ISO/IEC Directives, Part 2.

The main task of technical committees is to prepare International Standards. Draft International Standards adopted by the technical committees are circulated to the member bodies for voting. Publication as an International Standard requires approval by at least 75 % of the member bodies casting a vote.

Attention is drawn to the possibility that some of the elements of this document may be the subject of patent rights. ISO shall not be held responsible for identifying any or all such patent rights.

ISO 11665-4 was prepared by Technical Committee ISO/TC 85, *Nuclear energy, nuclear technologies, and radiological protection*, Subcommittee SC 2, *Radiological protection*.

ISO 11665 consists of the following parts, under the general title *Measurement of radioactivity in the environment — Air: radon-222*:

- *Part 1: Origins of radon and its short-lived decay products and associated measurement methods*
- *Part 2: Integrated measurement method for determining average potential alpha energy concentration of its short-lived decay products*
- *Part 3: Spot measurement method of the potential alpha energy concentration of its short-lived decay products*
- *Part 4: Integrated measurement method for determining average activity concentration using passive sampling and delayed analysis*
- *Part 5: Continuous measurement method of the activity concentration*
- *Part 6: Spot measurement method of the activity concentration*
- *Part 7: Accumulation method for estimating surface exhalation rate*
- *Part 8: Methodologies for initial and additional investigations in buildings*

The following parts are under preparation:

- *Part 9: Method for determining exhalation rate of dense building materials*
- *Part 10: Determination of diffusion coefficient in waterproof materials using activity concentration measurement*

Introduction

Radon isotopes 222, 220 and 219 are radioactive gases produced by the disintegration of radium isotopes 226, 224 and 223, which are decay products of uranium-238, thorium-232 and uranium-235 respectively, and are all found in the earth's crust. Solid elements, also radioactive, followed by stable lead are produced by radon disintegration^[1].

When disintegrating, radon emits alpha particles and generates solid decay products, which are also radioactive (polonium, bismuth, lead, etc.). The potential effects on human health of radon lie in its solid decay products rather than the gas itself. Whether or not they are attached to atmospheric aerosols, radon decay products can be inhaled and deposited in the bronchopulmonary tree to varying depths according to their size.

Radon is today considered to be the main source of human exposure to natural radiation. The UNSCEAR (2006) report^[2] suggests that, at the worldwide level, radon accounts for around 52 % of global average exposure to natural radiation. The radiological impact of isotope 222 (48 %) is far more significant than isotope 220 (4 %), while isotope 219 is considered negligible. For this reason, references to radon in this part of ISO 11665 refer only to radon-222.

Radon activity concentration can vary by one to multiple orders of magnitude over time and space. Exposure to radon and its decay products varies tremendously from one area to another, as it depends firstly on the amount of radon emitted by the soil and the building materials in each area and, secondly, on the degree of containment and weather conditions in the areas where individuals are exposed. Human exposure to radon is mainly linked to habitat and workplace. Long-term integrated measurement methods are applicable in assessing human exposure to radiation^[3]. For reasons of cost and ease of use, long-term measurements (over a period of several months) are only performed with passive sampling^{[4][5]}.

The values commonly found in the continental environment are usually between a few becquerels per cubic metre and several thousand becquerels per cubic metre. Activity concentrations of one becquerel per cubic metre or less can be observed in the oceanic environment. Mean annual values of radon activity concentrations inside houses can vary from several tens of becquerels per cubic metre to several thousands of becquerels per cubic metre^[2]. Activity concentrations can reach several thousands of becquerels per cubic metre in very confined spaces.

The activity concentration of radon-222 in the atmosphere can be measured by spot, continuous and integrated measurement methods with active or passive air sampling (see ISO 11665-1). This part of ISO 11665 deals with radon-222 integrated measurement techniques with passive sampling.

NOTE The origin of radon-222 and its short-lived decay products in the atmospheric environment and other measurement methods are described generally in ISO 11665-1.

Measurement of radioactivity in the environment — Air: radon-222 —

Part 4: Integrated measurement method for determining average activity concentration using passive sampling and delayed analysis

1 Scope

This part of ISO 11665 describes radon-222 integrated measurement techniques with passive sampling. It gives indications for determining the average activity concentration of the radon-222 in the air from measurements based on easy-to-use and low-cost passive sampling, and the conditions of use for the sensors.

This part of ISO 11665 covers samples taken without interruption over periods varying from a few days to one year.

This measurement method is applicable to air samples with radon activity concentrations greater than 5 Bq/m³.

2 Normative references

The following referenced documents are indispensable for the application of this document. For dated references, only the edition cited applies. For undated references, the latest edition of the referenced document (including any amendments) applies.

ISO 11665-1, *Measurement of radioactivity in the environment — Air: radon-222 — Part 1: Origins of radon and its short-lived decay products and associated measurement methods*

ISO 11929, *Determination of the characteristic limits (decision threshold, detection limit and limits of the confidence interval) for measurements of ionizing radiation — Fundamentals and application*

ISO/IEC 17025, *General requirements for the competence of testing and calibration laboratories*

IEC 61577-1, *Radiation protection instrumentation — Radon and radon decay product measuring instruments — Part 1: General principles*

3 Terms, definitions and symbols

3.1 Terms and definitions

For the purposes of this document, the terms and definitions given in ISO 11665-1 apply.

3.2 Symbols

For the purposes of this document, the symbols given in ISO 11665-1 and the following apply.

\bar{C}	average activity concentration, in becquerels per cubic metre
\bar{C}^*	decision threshold of the average activity concentration, in becquerels per cubic metre
$\bar{C}^\#$	detection limit of the average activity concentration, in becquerels per cubic metre

\bar{c}^{\leftarrow}	lower limit of the confidence interval of the average activity concentration, in becquerels per cubic metre
\bar{c}^{\rightarrow}	upper limit of the confidence interval of the average activity concentration, in becquerels per cubic metre
t	sampling duration, in hours
U	expanded uncertainty calculated by $U = k \cdot u()$ with $k = 2$
$u()$	standard uncertainty associated with the measurement result
$u_{\text{rel}}()$	relative standard uncertainty
μ	quantity to be measured
μ_0	background level
ω	correction factor linked to the calibration factor and the sampling duration

4 Principle

Integrated measurement of the average radon activity concentration is based on the following elements:

- continuous, passive sampling of an air sample representative of the atmosphere under investigation, by free convection and natural diffusion for a sensor in an open configuration (open to the air) or by natural diffusion for a sensor in a closed configuration (with an accumulation chamber);
- simultaneous accumulation of a measurable physical quantity (etched tracks, electric charges, radioactive atoms, etc.) on a suitable sensor;
- measurement of the accumulated physical quantity with a direct link to the average radon activity concentration over the sampling period in question.

Several measurement methods meet the requirements of this part of ISO 11665. They are basically distinguished by the type of accumulated physical quantity and how it is measured. The physical quantity and its related measurement may be as follows, for example:

- “latent tracks” produced in a polymer [solid-state nuclear track detector (SSNTD)] by ionization from alpha particles of the radon and its decay products; these latent tracks are detected and counted (see Annex A);
- charges produced in a solid [semi-conductor medium (silicon)] by ionisation from alpha particles of the radon and its decay products; they are detected by related electronics;
- discharge of an electret (non-rechargeable, positively charged element) by ionisation of the air due to the radioactive disintegration of radon and its decay products; the voltage variation relating to this discharge is measured (see Annex B);
- atoms of ^{222}Rn adsorbed on charcoal; the gamma emission rates of the decay products ^{214}Pb and ^{214}Bi are measured with a gamma spectrometer (see Annex C).

NOTE Analysis of the physical quantity might not be immediate and might require laboratory operations.

The result of integrated measurement is the exposure of a sensor to radon over the sampling duration in question. The average radon activity concentration is calculated by dividing the exposure result by the sampling duration.

5 Equipment

The apparatus shall include the following:

- a) a sensor which collects the physical quantity (SSNTD, silicon detector, electret detector, activated charcoal, etc.), either alone or with an accumulation chamber made from a conductive plastic material with a known detection volume; in closed configuration, the sensor is placed in a closed accumulation chamber with a filter and in open configuration, the sensor is in direct relation with the atmosphere (no accumulation chamber);
- b) a detection system adapted to the accumulated physical quantity.

The necessary equipment for each measurement method is specified in Annexes A, B and C respectively.

6 Sampling

6.1 Sampling objective

The sampling objective is to place, without interruption, an air sample representative of the atmospheric medium under investigation in contact with the sensor (SSNTD, silicon detector, electret detector, activated charcoal, etc.).

6.2 Sampling characteristics

Sampling is passive.

In the closed configuration, sampling is performed through a filtering medium, thus only radon alpha particles are detected by the sensor (see Clause 5). Sampling shall be performed in conditions that preclude clogging of the filtering medium, which would result in modified measuring conditions. Clogging during sampling can lead to the non-renewal of air in the accumulation chamber.

Using an open configuration, the sensor simultaneously records the alpha emissions of the radon and those of its decay products near its surface. It also records any alpha emitter present in the analysed atmosphere, in the energy range specified by the manufacturer. This configuration shall be used under conditions that preclude fouling (dust-filled atmosphere, grease deposit, etc.) of the sensor, which would result in modified measuring conditions.

6.3 Sampling conditions

6.3.1 General

Sampling shall be carried out as specified in ISO 11665-1.

6.3.2 Installation of the sensor

Installation of the sensor shall be carried out as specified in ISO 11665-1.

In the specific case of indoor measurement, the sensor should be placed on a clear surface between 1 m and 2 m above the ground, under the following conditions:

- a) a clear space of at least 20 cm should be left around the sensor to avoid the influence of thoron exhalation from the walls;
- b) the sensor should be placed away from any heat sources (radiator, chimney, electrical equipment, television, direct sunlight, etc.) and from areas of traffic, doors and windows, walls and natural ventilation sources;
- c) the installation conditions should not be disturbed during measurement (books falling, engineers working, curiosity, etc.); recommendations should be made to occupants in order to prevent the change of sampling conditions;
- d) the sensor should also be made secure during measurement, in order to prevent any damage.

6.3.3 Sampling duration

The sampling duration is equal to the time interval between installation and removal of the sensor at the sampling point.

Time of installation and removal of the sensor shall be recorded (date and hour).

The sampling duration shall be adjusted to suit the phenomenon under investigation, the assumed radioactivity and the sensor characteristics (see Table 1).

Table 1 — Examples of sampling characteristics of the various measurement methods meeting the requirements of this part of ISO 11665

Sensor	Annex (normative)	Sampling place	Sampling duration/ Exposure time
Solid-state nuclear track detector (open configuration)	A	Indoors	One week to several months
Solid-state nuclear track detector (closed configuration)			
Electret detector	B	Outdoors or indoors	Few days to several months
Activated charcoal	C		Few days

The sampling duration shall be determined on the basis of the intended use of the measurement results.

For example, indoor concentrations vary not only over a day but also between days of the week because of variations in occupancy. In this case, it would be reasonable to sample over a whole week in order to include these variations.

NOTE To approach the annual average value of the radon activity concentration in the buildings and not underestimate it, it is advisable to perform measurements for at least two months (see ISO 11665-8).

Users should be aware of the saturation characteristics of their sensors and should adapt the sampling duration to ensure that saturation does not occur.

6.3.4 Volume of air sampled

For passive sampling, direct measurement of the air volume sampled is not necessary. A calibration factor, in activity per unit volume, shall be used.

7 Detection

Depending on the sensor used, detection shall be carried out using solid-state nuclear track detectors (SSNTD), discharge of a polarized surface inside an ionization chamber, gamma-ray spectrometry or liquid scintillation, as described in ISO 11665-1.

8 Measurement

8.1 Procedure

The measurement procedure for each measurement method shall be as specified in Annexes A, B and C respectively.

8.2 Influence quantities

Various quantities can lead to measurement bias that could induce non-representative results. Depending on the measurement method and the control of usual influence quantities specified in IEC 61577-1 and

ISO 11665-1, the influence quantities of particular importance for each measurement method described in this part of ISO 11665 are specified in Annexes A, B and C respectively.

Manufacturer recommendations in the operating instructions for the sensors shall be followed.

8.3 Calibration

The measuring system (sensor and detection system) shall be calibrated as specified in ISO 11665-1. Additional requirements for the devices used for particular methods are specified in the relevant annexes (see Annexes A, B and C).

The relationship between the physical quantity recorded by the sensor (number of etched tracks, number of electric charges, pulse count and amplitudes, etc.) and the activity concentration of the radon in the air shall be established based on the measurement of a radon-222 reference atmosphere. The radon-222 activity concentration in the reference atmosphere shall be traceable to a primary radon-222 gas standard.

In addition to calibration, consideration should be given to regular testing to ensure measurements remain suitable for use. These should include internal blind tests and external proficiency, validation or interlaboratory comparisons.

9 Expression of results

9.1 Average radon activity concentration

The average radon activity concentration shall be calculated as given in Formula (1):

$$\bar{C} = (\mu - \mu_0) \cdot \omega \quad (1)$$

9.2 Standard uncertainty

In accordance with ISO/IEC Guide 98-3, the standard uncertainty of \bar{C} shall be calculated as given in Formula (2):

$$u(\bar{C}) = \sqrt{\omega^2 \cdot [u^2(\mu) + u^2(\mu_0)] + \bar{C}^2 \cdot u_{\text{rel}}^2(\omega)} \quad (2)$$

9.3 Decision threshold and detection limit

The characteristic limits associated with the measurand shall be calculated in accordance with ISO 11929. Examples of the calculations of uncertainties and characteristic limits are detailed in Annexes A, B and C for each respective measurement method described.

9.4 Limits of the confidence interval

The lower, \bar{C}^{\triangleleft} , and upper, \bar{C}^{\triangleright} , limits of the confidence interval shall be calculated using Formulae (3) and (4) (see ISO 11929):

$$\bar{C}^{\triangleleft} = \bar{C} - k_p \cdot u(\bar{C}); p = \omega \cdot (1 - \gamma/2) \quad (3)$$

$$\bar{C}^{\triangleright} = \bar{C} + k_q \cdot u(\bar{C}); q = 1 - \omega \cdot \gamma/2 \quad (4)$$

where

$$\omega = \Phi[y/u(y)], \Phi \text{ being the distribution function of the standardized normal distribution;}$$

$$\omega = 1 \text{ may be set if } \bar{C} \geq 4 \cdot u(\bar{C}), \text{ in which case:}$$

$$\bar{C}^{\langle\Delta\rangle} = \bar{C} \pm k_{1-\gamma/2} \cdot u(\bar{C}) \quad (5)$$

$\gamma = 0,05$ with $k_{1-\gamma/2} = 1,96$ are often chosen by default.

10 Test report

10.1 The test report shall be in accordance with the requirements of ISO/IEC 17025 and shall contain the following information:

- a) reference to this part of ISO 11665, i.e. ISO 11665-4:2012;
- b) measurement method (integrated);
- c) identification of the type of sensor;
- d) identification of the sample;
- e) sampling characteristic (passive);
- f) sampling times: start and end time (date and hour);
- g) duration of sampling;
- h) sampling location;
- i) units in which the results are expressed;
- j) test result, $\bar{C} \pm u(\bar{C})$ or $\bar{C} \pm U$, with the associated k value.

10.2 Complementary information may be provided, such as the following:

- a) purpose of the measurement;
- b) probabilities α , β and $(1-\gamma)$;
- c) the decision threshold and the detection limit; depending on the customer request, there are different ways to present the result:
 - 1) when the average radon activity concentration is compared with the decision threshold (see ISO 11929), the result of the measurement shall be expressed as $\leq \bar{C}^*$ if the result is below the decision threshold;
 - 2) when the average radon activity concentration is compared with the detection limit, the result of the measurement shall be expressed as $\leq \bar{C}^\#$ if the result is below the detection limit or, if the detection limit exceeds the guideline value, it shall be documented that the method is not suitable for the measurement purpose;
- d) any relevant information likely to affect the results, for example:
 - 1) weather conditions at the time of sampling;
 - 2) ventilation conditions for indoor measurement (mechanical ventilation system, doors and windows open or shut, etc.).

10.3 The results can be expressed in a similar format to that shown in ISO 11665-1:2012, Annex C.

Annex A (normative)

Measurement method using a solid-state nuclear track detector (SSNTD)

A.1 General

This annex deals with the solid-state nuclear track detector (SSNTD) method, which is one of several methods meeting the requirements of this part of ISO 11665.

For the purposes of this annex, the symbols given in Clause 3 and the following apply.

F_c	calibration factor, in (tracks per square centimetre) per (becquerel hour per cubic metre)
n	number of solid-state nuclear detectors used for determining the background noise
n_g	number of tracks after exposure
\bar{n}_b	mean number of tracks caused by the background noise
S_{SSNTD}	SSNTD area used for counting the number of “etched tracks”, in square centimetres

A.2 Principle

The integrated measurement of the average radon activity concentration using an SSNTD is based on the following elements:

- a) passive sampling, during which the alpha particles, including those produced by the disintegration of radon and its short-lived decay products, transfer their energy by ionizing or exciting the atoms in the polymer; this energy that is transferred to the medium leaves areas of damage called “latent tracks”;
- b) transport of the exposed sensors to the laboratory for the appropriate chemical, or electrochemical, processing, for example the transformation of the “latent tracks” into “etched tracks” counted with a suitable system; the number of these “etched tracks” per surface unit area is linked to the exposure of the radon by the calibration factor previously defined for sensors from the same manufacturing batch of SSNTD processed chemically, or electrochemically, and counted under the same conditions;
- c) determination of the average activity concentration from the radon exposure value, the sampling duration and consideration of the background noise.

A.3 Equipment

The apparatus shall include the following:

- a) a sensor in the form of a solid-state nuclear track detector (SSNTD), used alone or with an accumulation chamber made from a conductive plastic material with a known detection volume;
- b) equipment and suitable chemical reagents for etching the sensor;
- c) equipment suitable for scanning and counting the “etched tracks”.

The SSNTD shall be made of a polymer that is sensitive to alpha particles.

The sensor shall be fixed on a support that can be used in either an open or closed configuration (see Figure A.1).

In an open configuration, the sensor can record simultaneously the alpha emissions of radon and its decay products close to the detector and of any other alpha emitter present in the analysed atmosphere, in the energy range specified by the manufacturer. It is necessary to know the equilibrium factor, amongst other things, in order to exploit the results obtained with this sensor. If this parameter is not measured, the value commonly used inside houses is equal to 0,4^[3].

In its closed configuration, the sensor has a chamber that serves as the detection volume. This configuration is used to overcome the influence of the solid radon decay products and of any other solid alpha-emitting radionuclide present in the analysed atmosphere. This is achieved by the presence of a filter between the external environment and the accumulation chamber, which prevents the passage of solid radon decay products or any other solid alpha-emitting radionuclide. In this case, knowing the equilibrium factor is not necessary.

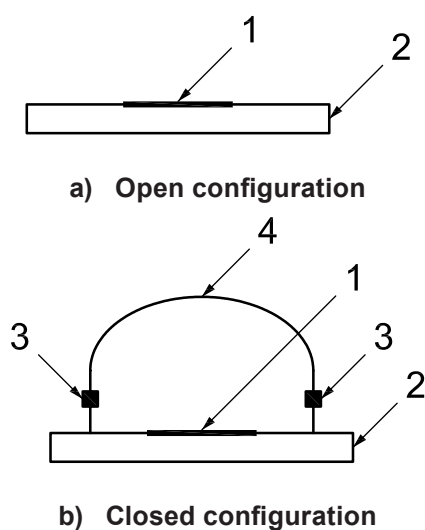

Keys

- 1 SSNTD
- 2 support
- 3 filter
- 4 accumulation chamber

Figure A.1 — Solid-state nuclear track detectors in open and closed configurations

A.4 Sampling

Air sampling shall be passive.

Sampling of the air and generation of the “latent tracks” on the sensor shall be carried out simultaneously.

Installation of the sensor shall be performed in accordance with 6.3.2 and ISO 11665-1.

When the sensor is not in the measurement mode, it is normally enclosed in sealed packaging which prevents the penetration of radon and its decay products. The sensor begins measuring when it is removed from this packaging at the place of installation. The measurement ceases when the sensor is removed from the installation place and immediately returned to the sealed packaging.

Time of installation and removal phases shall be recorded (date and hour).

The sampling duration shall comply with 6.3.3.

The sampling duration shall be adapted to the assumed level of radon activity concentration. If a very high level of activity concentration is assumed, the sampling duration shall be reduced to avoid saturating the SSNTD. Conversely, if a very low level of activity concentration is assumed, the sampling duration shall be extended so as to produce a significant physical variable.

A.5 Measurement

A.5.1 Procedure

Measurement shall be carried out as follows.

- a) Select and locate the measuring site.
- b) Install the sensor.
- c) Record the location and the time (date and hour) of installation of the sensor.
- d) Carry out sampling of an air sample representative of the atmosphere under investigation.
- e) Remove the sensor.
- f) Record the time (date and hour) of removal of the sensor.
- g) Send the sensor to the laboratory within a few days of the end of the exposure period. It shall be processed as soon as possible, unless a storage method is validated, in which case the sensors may be processed later.
- h) Remove the SSNTD from the accumulation chamber if needed.
- i) Develop the sensor by etching with a suitable chemical, or electrochemical, treatment. The “latent tracks” caused by the alpha particles produced by the disintegration of the radon and its short-lived decay products are converted into “etched tracks”.
- j) Scan the sensor and count the number of “etched tracks”.
- k) Determine the background noise of the sensor using a statistically significant number of randomly chosen sensors from each manufacturing batch. Avoid reliance on data provided by the manufacturer which will not include adventitious radon exposure during storage and transit to the processing laboratory. Sensors from the same batch of SSNTD shall be developed and counted as described in steps i) to j). The number of sensors used should be sufficient to determine n_b . Typically this should be at least 10 sensors, or 1% of the total number of available sensors per manufacturing batch, depending on the consistency of the background noise of the sensors within each batch.
- l) Determine the average activity concentration by calculation.

A.5.2 Influence quantities

Besides the influence quantities stated in IEC 61577-1 and ISO 11665-1, the following shall be taken into account:

- a) Direct exposure of a sensor with an open configuration: in an indoor environment with a highly-significant aerosol content (kitchen, bathroom, cellar, etc.), this can cause pollution on the sensor surface, thereby potentially invalidating the results. It is advisable to use closed chambers in such environments.
- b) The equilibrium factor: in an open configuration, the activity concentration of the radon decay products shall also be taken into account, as well as the variation in the equilibrium factor^{[8][9]}. Either the equilibrium factor shall be measured or a sensor with a closed configuration shall be used.
- c) The ageing effect of the SSNTD: in order to avoid the effect of ageing, the sensor shall be used before the expiry date given by the manufacturer.

A.5.3 Calibration

If the calibration factor is not provided by manufacturer, each batch of sensors shall be calibrated upon receipt.

For a batch of sensors, calibration involves exposing a statistically significant number of sensors, typically at least 10 randomly chosen sensors per manufacturing batch, to reference atmospheres and applying the same chemical, or electrochemical, processing and track counting as used for measurement samples. Avoid reliance on data provided by the manufacturer unless you have verified that your processing methods exactly replicate

the manufacturer's. The number of sensors used should be sufficient to determine F_c . Typically this should be at least 10 sensors, or 1% of the total number of available sensors per manufacturing batch, depending on the consistency of the calibration results of the sensors within each batch. The result is the calibration factor. It is the ratio between the density of the tracks (tracks/cm²) and the exposure to radon activity concentration in a reference atmosphere (Bq·h/m³). This calibration factor is expressed in (tracks per square centimetre) per (becquerel hour per cubic metre) [(tracks/cm²) per (Bq·h/m³)].

At the same time as the calibration, the background noise shall be measured on 10 sensors from the same batch.

For a sensor with an open configuration, the calibration factor, F_c , shall take into account the value of the equilibrium factor of the reference atmosphere. The results can also fluctuate due to the lack of sensor protection in a very humid medium or one loaded with aerosols. As an indication, conversion factors from 0,000 5 tracks/cm² per Bq·h/m³ up to 0,004 tracks/cm² per Bq·h/m³ are found in published works depending on the type of sensor^[9].

A.6 Expression of results

A.6.1 Average radon activity concentration

The average radon activity concentration is obtained from Formula (1). This yields Formula (A.1):

$$\bar{C} = (n_g - \bar{n}_b) \cdot \frac{1}{t \cdot S_{SSNTD} \cdot F_c} = (n_g - \bar{n}_b) \cdot \omega \quad \text{with} \quad \omega = \frac{1}{t \cdot S_{SSNTD} \cdot F_c} \quad (\text{A.1})$$

For the most accurate value, \bar{n}_b is determined experimentally by reading n sensors that have not been exposed to radon and have been processed under the same physico-chemical and counting conditions. The value of \bar{n}_b may also be given by the manufacturer.

A.6.2 Standard uncertainty

The standard uncertainty of \bar{C} is obtained from Formula (2). This yields Formula (A.2):

$$u(\bar{C}) = \sqrt{\left(n_g + \frac{\bar{n}_b}{n}\right) \cdot \omega^2 + \bar{C}^2 \cdot u_{\text{rel}}^2(\omega)} \quad (\text{A.2})$$

with

$$u_{\text{rel}}^2(\omega) = u_{\text{rel}}^2(F_c) + u_{\text{rel}}^2(S_{SSNTD})$$

The uncertainty of the sampling duration is considered negligible.

Calculation of the characteristic limits (see ISO 11929) requires calculation of $\tilde{u}(\tilde{C})$, i.e. the standard uncertainty of \tilde{C} as a function of its true value, calculated as given in Formula (A.3):

$$\tilde{u}(\tilde{C}) = \sqrt{\left[\frac{\tilde{C}}{\omega} + \bar{n}_b \cdot \left(1 + \frac{1}{n}\right)\right] \cdot \omega^2 + \tilde{C}^2 \cdot u_{\text{rel}}^2(\omega)} \quad (\text{A.3})$$

A.6.3 Decision threshold

The decision threshold, \bar{C}^* , is obtained from Formula (A.3) for $\tilde{C} = 0$ (see ISO 11929).

This yields Formula (A.4):

$$\bar{C}^* = k_{1-\alpha} \cdot \tilde{u}(0) = k_{1-\alpha} \cdot \omega \cdot \sqrt{\bar{n}_b \cdot \left(1 + \frac{1}{n}\right)} \quad (\text{A.4})$$

$\alpha = 0,05$ with $k_{1-\alpha} = 1,65$ is often chosen by default.

A.6.4 Detection limit

The detection limit, $\bar{C}^{\#}$, is calculated as given in Formula (A.5) (see ISO 11929):

$$\bar{C}^{\#} = \bar{C}^* + k_{1-\beta} \cdot \tilde{u}(\bar{C}^{\#}) = \bar{C}^* + k_{1-\beta} \cdot \sqrt{\left[\frac{\bar{C}^{\#}}{\omega} + \bar{n}_b \cdot \left(1 + \frac{1}{n} \right) \right] \cdot \omega^2 + \bar{C}^{\#2} \cdot u_{\text{rel}}^2(\omega)} \quad (\text{A.5})$$

The detection limit can be calculated by solving Formula (A.5) for $\bar{C}^{\#}$ or, more simply, by iteration with a starting approximation $\bar{C}^{\#} = 2 \cdot \bar{C}^*$ in terms of the right side of Formula (A.5).

One obtains $\bar{C}^{\#}$ with $k_{1-\alpha} = k_{1-\beta} = k$:

$$\bar{C}^{\#} = \frac{2 \cdot \bar{C}^* + k^2 \cdot \omega}{1 - k^2 \cdot u_{\text{rel}}^2(\omega)} \quad (\text{A.6})$$

Values $\alpha = \beta = 0,05$ and therefore $k_{1-\alpha} = k_{1-\beta} = 1,65$ are often chosen by default.

A.6.5 Example

The number of tracks for a sensor with a closed configuration exposed for 90 days ($t = 2\,160$ h) is $n_g = 800$ tracks.

The number of tracks, determined on 10 non-exposed sensors from the same batch, caused by the background noise over 90 days, is $\bar{n}_b = 30$ tracks.

The determination of n_g and \bar{n}_b is performed over the same area: $S_{\text{SSNTD}} = 1 \pm 0,1 \text{ cm}^2$.

The calibration factor is $F_C = (8 \pm 0,8) \times 10^{-4}$ tracks/cm² per Bq·h/m³.

The average radon activity concentration, calculated from Formula (A.1), is:

$$\bar{C} = 446 \text{ Bq/m}^3$$

The standard uncertainty of the average radon activity concentration, calculated from Formula (A.2), is:

$$u(\bar{C}) = 65 \text{ Bq/m}^3$$

Thus, the average radon activity concentration is:

$$\bar{C} = (446 \pm 65) \text{ Bq/m}^3$$

The decision threshold, \bar{C}^* , obtained from Equation (A.4), is:

$$C^* = 5 \text{ Bq/m}^3$$

The detection limit, $\bar{C}^{\#}$, calculated by Formula (A.6), is:

$$C^{\#} = 13 \text{ Bq/m}^3$$

Annex B (normative)

Measurement method using an electret detector

B.1 General

This annex deals with the electret detector method, which is one of several methods meeting the requirements of this part of ISO 11665.

For the purposes of this annex, the symbols given in Clause 3 and the following apply.

U_i	initial electret voltage, in volts
U_f	final electret voltage, in volts
B_G	contribution by the ambient gamma radiation, in becquerels per cubic metre
F_C	calibration factor, in (volts per hour) per (becquerel per cubic metre)
b	electret parameter, given by the manufacturer, in (volts per hour) per (becquerel per cubic metre)
d	electret parameter, given by the manufacturer, in (per hour) per (becquerel per cubic metre)
f_{cor}	correction factor for the gamma radiation, given by the manufacturer, in (becquerels per cubic metre) per (nanogray per hour)
\dot{D}	average dose rate due to ambient gamma radiation during the exposure period, in nanograys per hour

B.2 Principle

The integrated measurement of the average radon activity concentration using an electret detector is based on the following elements:

- Passive sampling, during which the radon and its decay products formed in the accumulation chamber ionize the air. The electret being charged positively, an electrostatic field is created between the electret surface and the accumulation chamber walls. The electret serves both as the anode of the electrostatic field and the collector electrode. The electrons produced by the air ionization combine with the positive charges of the electret. This leads to a gradual decrease of its voltage.
- Measuring the electret voltage before and after every exposure to the atmosphere under investigation with a voltmeter specific to the device.
- Measuring the average dose rate due to ambient environmental (cosmic and terrestrial) gamma radiation at the sampling place. The ambient gamma radiation contributes to discharging the electret detector.
- Determining the average activity concentration from the voltage drop, the sampling duration and consideration of the average dose rate.

B.3 Equipment

The apparatus shall include the following:

- a measuring device, which includes a dielectric disk of polytetrafluoroethylene (PTFE) or fluorinated ethylene propylene (FEP), known as an electret and a removable accumulation chamber with a known

detection volume (see Figure B.1)^[10]; the removable accumulation chamber shall be made of a conductive plastic material and shall contain filters;

- b) a voltmeter to measure the electret voltage immediately before and after exposure to the atmosphere under investigation;
- c) a dosimeter to measure the average dose rate at the sampling place.

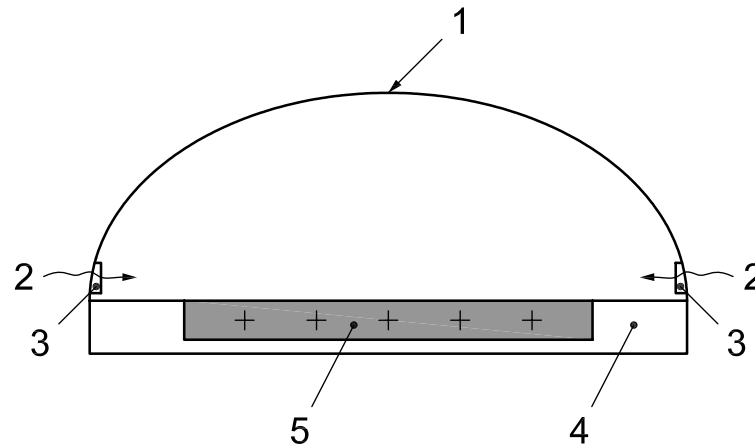

Key

- 1 accumulation chamber
- 2 entry point of radon
- 3 filter
- 4 insulating support
- 5 electret detector

Figure B.1 — Configuration of a measuring device using an electret detector

There are various types of electret detector and chamber (see Table B.1). The electret detector is charged positively at the factory by the manufacturer to a potential in the order of several hundred volts (750 V). It may be used several times until its voltage limit value (200 V) is reached, as the field induced is then too low for effective ion collection. The voltage limit value is given by the manufacturer.

Table B.1 — Example of types of accumulation chamber and electret detector

Accumulation chamber		Electret detector	
Type	Volume ml	Type	Sensitivity
n	50	1	high
m	210	2	low

Several combinations are possible.

By way of example, three combinations are presented in Figure B.2. For each combination, the letter (n or m) refers to the type of accumulation chamber and the number (1 or 2) indicates the type of electret detector (see Table B.1). An ambient gamma radiation equal to 100 nGy/h and a voltage drop of 30 V are considered in this example. The upper and lower limits of each response field relate, respectively, to an electret detector with the maximum charge voltage (used from 750 V to 720 V) and an electret detector at the end of its life (used from 230 V to 200 V).

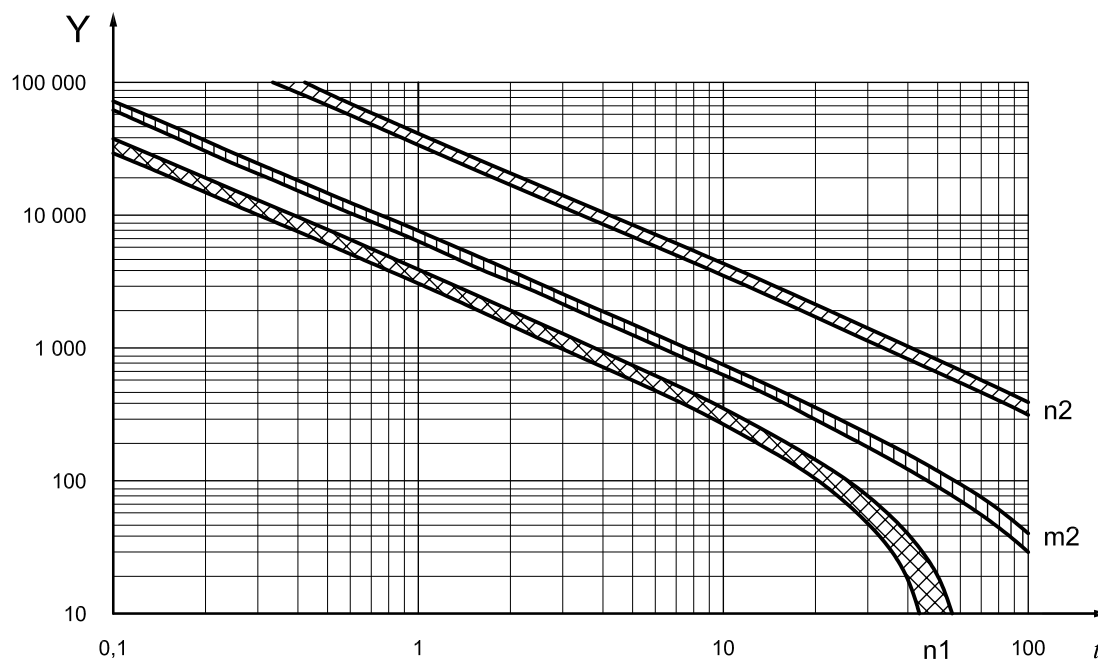

Key

- t time, in days
- Y radon activity concentration, in becquerels per cubic metre (Bq/m³)

Figure B.2 — Radon activity concentration measured over a given sampling duration for an electret voltage drop of 30 V (assuming a 100 nGy/h ambient gamma radiation contribution) — Example for the three combinations n1, m2 and n2

Several examples can be extracted from this graph. Thus, for an average activity concentration of 200 Bq/m³ and an ambient dose rate of 100 nGy/h, the sampling duration for the n1 combination (see Table B.1) required to produce a drop of 30 V in the electret potential is equal to 12 days (see Table B.2).

B.4 Sampling

Air sampling shall be passive.

During the sampling duration (exposure period), radon penetrates the accumulation chamber by diffusion through filters which prevent the aerosols present in the air at the time of sampling, especially radon decay products, from entering the chamber.

Installation of the measuring device shall be carried out in accordance with 6.3.2 and ISO 11665-1.

Time of installation and removal phases shall be recorded (date and hour).

The sampling duration shall be in accordance with 6.3.3 and shall be adapted to the assumed level of radioactivity and the electret-chamber pairing (see Table B.2). Nomographs relate the average radon activity concentration and the sampling duration as well as the type of electret detector and the accumulation chamber (see Figure B.2).

Table B.2 — Examples of sampling duration, in hours, for different combinations (accumulation chamber/electret detector) and a voltage drop of 30 V

Average radon activity concentration Bq/m ³	Sampling duration for the combination		
	n1	m2	n2
200	288	672	> 2 400
400	168	360	2 040
1 000	72	156	840

It is advisable to use combination n2 to assess human exposure. Combination n1 is, however, preferable for a rapid determination of the average radon activity concentration.

The graph in Figure B.2 may be used for an electret voltage drop other than 30 V. This requires an understanding of the following:

- a) for a fixed average radon activity concentration, the electret voltage drop is proportional to the sampling duration;
- b) for a fixed sampling duration, the electret voltage drop is proportional to the average radon activity concentration.

B.5 Measurement

B.5.1 Procedure

Integrated measurement of the radon activity concentration using an electret detector shall be carried out as follows.

- a) Select and locate the sampling site.
- b) Select the electret-chamber pairing by using the nomographs given by the manufacturer (see Figure B.2). For a given sampling duration, the following are taken into account when choosing the electret-chamber pairing:
 - 1) expected average radon activity concentration;
 - 2) residual electret potential;
 - 3) characteristics of the electret surface;
 - 4) volume of the associated accumulation chamber.
- c) Measure and record the initial electret voltage before exposure.
- d) Assemble the accumulation chamber and the electret.
- e) Install the measuring device.
- f) Measure and record the ambient gamma dose rate at the sampling site.
- g) Record the location and the time (date and hour) of installation of the measuring device.
- h) Carry out sampling of an air sample representative of the atmosphere under investigation.
- i) Disassemble the accumulation chamber and the electret.
- j) Measure and record the final electret voltage immediately after the end of exposure.
- k) Measure and record the ambient gamma dose rate at the sampling site at the end of the measurement period.
- l) Record the time (date and hour) of removal of the measuring device.
- m) Determine the average activity concentration by calculation.

B.5.2 Influence quantities

Besides the influence quantities specified in IEC 61577-1 and ISO 11665-1, the following shall be taken into account:

- a) The temperature: The electret voltage shall be measured before and after exposure to the atmosphere under investigation at the same temperature conditions. The electret surface tends to become convex or concave when a substantial variation in temperature occurs. It may therefore be different to the electrometer sensor when the voltage is read. A substantial variation in the electrometer temperature affects the value of the electret voltage.
- b) The presence of dust on the electret surface: Check after measurement, and before measurement when reusing an electret.
- c) The conservation of the physical quantity collected after sampling has ended: The voltage shall be measured immediately at the end of the exposure period.
- d) The ambient gamma radiation contributes to discharging the electret. It is therefore necessary to measure the dose rate at the sampling place at least twice, once at the beginning and once at the end of the measurement period;
- e) The electrometer storage conditions: The electrometer shall always be stored in an area containing dry air (a desiccant maintains its level of humidity) to ensure that it indicates acceptable voltage values.
- f) The effect of physical shock on the response of electret detectors is well known and can cause an undetermined source of error. Care should therefore be taken to avoid shocks during the measurement.

Manufacturer recommendations in the operating instructions for the sensors shall be respected.

B.5.3 Calibration

Calibration involves exposing several measuring devices (electret and accumulation chamber) to reference radon atmospheres. The electret voltage shall be measured by a specific electrometer before and after exposure to the reference atmosphere.

The gamma radiation dose rate shall be measured simultaneously.

The difference in potential thus determined is linked to the reference activity concentration.

The result obtained is the value of the calibration factor depending on the electret detector. This calibration factor is given by the manufacturer.

The electrometer response shall be checked regularly with reference electrets.

The correction factor of gamma radiation shall be determined by exposing several measuring devices (electret and accumulation chamber) to reference gamma radiation dose rates.

B.6 Expression of results

B.6.1 Average radon activity concentration

The average radon activity concentration is calculated as given in Formula (B.1):

$$\bar{C} = \frac{U_i - U_f}{F_c \cdot t} - B_G \quad (\text{B.1})$$

The calibration factor, F_c , is a function of the initial and final electret voltages.

NOTE The expression of F_c depends on the type of electret detector used.

The contribution by the ambient gamma radiation, in radon equivalent, B_G , is calculated as given in Formula (B.2):

$$B_G = f_{\text{cor}} \cdot \dot{D} \quad (\text{B.2})$$

B.6.2 Standard uncertainty

In accordance with ISO/IEC Guide 98-3, the standard uncertainty of \bar{C} shall be calculated as given in Formula (B.3):

$$u(\bar{C}) = \sqrt{2 \cdot \frac{1}{(F_c \cdot t)^2} \cdot u^2(U_i) + u^2(B_G) + (\bar{C} + B_G)^2 \cdot u_{\text{rel}}^2(F_c)} \quad (\text{B.3})$$

where the uncertainty of sampling duration t is considered negligible.

$$u^2(B_G) = f_{\text{cor}}^2 \cdot u^2(\dot{D}) + \dot{D}^2 \cdot u^2(f_{\text{cor}})$$

where the uncertainties of the correction factor f_{cor} and the average dose rate \dot{D} are given by the manufacturer.

The electrometer reads the electret voltage to within 1 V and $u^2(U_i) = u^2(U_f) = \frac{1}{12}$.

B.6.3 Decision threshold and detection limit

The characteristic limits associated with \bar{C} shall be calculated according to ISO 11929. An example of the calculations of the decision threshold and the detection limit are detailed in B.6.4 for a specific type of electret detector.

B.6.4 Example

This subclause shows an example of measurement performed with a high-sensitivity electret associated with a 50 ml accumulation chamber.

The calibration factor is calculated as given in Formula (B.4):

$$F_c = b + d \cdot \left(\frac{U_i + U_f}{2} \right) \quad (\text{B.4})$$

where the constants b and d , provided by the manufacturer, are:

$$b = 2,94 \times 10^{-4} \text{ V/h per Bq/m}^3$$

$$d = 1,54 \times 10^{-7} \text{ h}^{-1} \text{ per Bq/m}^3$$

The relative uncertainty of the calibration factor F_c , provided by the manufacturer, is:

$$u_{\text{rel}}^2(F_c) = (0,06)^2$$

The chamber parameter is $f_{\text{cor}} = 0,594 \text{ 374 Bq/m}^3/\text{nGy/h}$.

The relative uncertainty of the chamber parameter f_{cor} , provided by the manufacturer, is:

$$u_{\text{rel}}^2(f_{\text{cor}}) = 9 \times 10^{-4}$$

The initial electret voltage is $U_i = 530 \text{ V}$

The final electret voltage after exposure is $U_f = 500 \text{ V}$.

Sampling duration is $t = 336 \text{ h}$.

The average dose rate during exposure is $\dot{D} = 100 \text{ nGy/h}$.

Thus, the average radon activity concentration, calculated from Formula (B.1), is given by:

$$\bar{C} = 180 \text{ Bq/m}^3$$

The dose rate measuring instrument indicates a dose rate with a 5 % uncertainty.

The standard uncertainty of the average radon activity concentration is calculated from Formula (B.3):

$$u(\bar{C}) = 15 \text{ Bq/m}^3$$

Thus, the average radon activity concentration is:

$$\bar{C} = (180 \pm 15) \text{ Bq/m}^3$$

Calculation of the characteristic limits (see ISO 11929) requires calculation of $\tilde{u}(\tilde{C})$, i.e. the standard uncertainty of \bar{C} as a function of its true value, calculated as given in Formula (B.5):

$$\tilde{u}(\tilde{C}) = \sqrt{\frac{1}{6} \cdot \left[\frac{1 + d \cdot \frac{t}{2} \cdot (\tilde{C} + B_G)}{t \cdot (b + d \cdot U_i)} \right]^2 + u^2(B_G) + (\tilde{C} + B_G)^2 \cdot u_{\text{rel}}^2(F_c)} \quad (\text{B.5})$$

The decision threshold, \bar{C}^* , is obtained from Equation (B.5) for $\tilde{C} = 0$ (see ISO 11929).

This yields Formula (B.6):

$$\bar{C}^* = k_{1-\alpha} \cdot \tilde{u}(0) = k_{1-\alpha} \cdot \sqrt{\frac{1}{6} \cdot \left[\frac{1 + d \cdot \frac{t}{2} \cdot B_G}{t \cdot (b + d \cdot U_i)} \right]^2 + u^2(B_G) + B_G^2 \cdot u_{\text{rel}}^2(F_c)} \quad (\text{B.6})$$

$\alpha = 0,05$ with $k_{1-\alpha} = 1,65$ is often chosen by default.

$$\bar{C}^* = k_{1-\alpha} \cdot \tilde{u}(0) = 10 \text{ Bq/m}^3$$

The detection limit, $\bar{C}^\#$, is calculated as given in Formula (B.7) (see ISO 11929):

$$\bar{C}^\# = \bar{C}^* + k_{1-\beta} \cdot \sqrt{\frac{1}{6} \cdot \left[\frac{1 + d \cdot \frac{t}{2} \cdot (\bar{C}^\# + B_G)}{t \cdot (b + d \cdot U_i)} \right]^2 + u^2(B_G) + (\bar{C}^\# + B_G)^2 \cdot u_{\text{rel}}^2(F_c)} \quad (\text{B.7})$$

$\beta = 0,05$ with $k_{1-\beta} = 1,65$ is often chosen by default.

The detection limit can be calculated by solving Formula (B.7) for $\bar{C}^\#$ or, more simply, by iteration with a starting approximation $\bar{C}^\# = 2 \cdot \bar{C}^*$ in terms of the right side of Formula (B.7).

One obtains $\bar{C}^\#$ with $k_{1-\alpha} = k_{1-\beta} = k$:

$$\bar{C}^\# = \frac{2 \cdot \bar{C}^* + k^2 \cdot \varepsilon_1}{1 - k^2 \cdot \varepsilon_2} \quad (\text{B.8})$$

with

$$\varepsilon_1 = \frac{1}{6} \cdot \left[\frac{d^2 \cdot \frac{t}{2} \cdot B_G + d}{t \cdot (b + d \cdot U_i)^2} \right] + 2 \cdot B_G \cdot u_{\text{rel}}^2(F_c) \quad (\text{B.9})$$

$$\varepsilon_2 = \frac{1}{6} \cdot \left(\frac{d \cdot \frac{t}{2}}{b + d \cdot U_i} \right)^2 + u_{\text{rel}}^2(F_c) \quad (\text{B.10})$$

$$\bar{C}^\# = 20 \text{ Bq/m}^3$$

Annex C (normative)

Measurement method using activated charcoal

C.1 General

This annex deals with an activated charcoal method, which is one of several methods meeting the requirements of this part of ISO 11665.

For the purposes of this annex, the symbols given in Clause 3 and the following apply.

F_C	calibration factor, in (per second) per (becquerel per cubic metre)
f_d	correction factor for the radioactive decay during the counting time and during the time between the reference instant ($t = 0$) and the measuring instant
f_H	correction factor for humidity, dimensionless
f_S	correction factor for difference between sampling period and reference calibration exposure period, dimensionless
n_b, n_{b0}	number of counts in the background of the peak, in the sample and in the background spectrum, respectively
n_g, n_{g0}	number of counts in the gross area of the peak, in the sample and in the background spectrum, respectively
n_N, n_{N0}	number of counts in the net area of the peak, in the sample and in the background spectrum, respectively
t_0	background counting duration, in seconds
t_g	sample counting duration, in seconds
t_i	measuring instant, i.e. time at which the sample measurement starts, in seconds
t_{sm}	time between mid-point of exposure and measurement of exposed detector, in seconds
λ_i	decay constant of the nuclide i , per second

C.2 Principle

Measurement includes the following stages:

- a) preparing the measurement device (sensor), as follows:
 - 1) removing the lid;
 - 2) heating the charcoal to a temperature of 110 °C in an atmosphere of nitrogen in order to remove water content (this step may be omitted but it shortens the useful life of the device);
 - 3) replacing the lid;
 - 4) weighing and recording the weight of the complete device;

- 5) adding additional sealing, if necessary, by applying adhesive tape around the seal between the lid and the base;
- b) passive sampling, during which radon is adsorbed onto the charcoal, as follows:
 - 1) the lid is removed at the beginning of the sampling period and replaced at the end of the sampling period;
 - 2) the sampling time and the start time are both recorded;
- c) sending the exposed field sensors to the laboratory for the measurement of the gamma emission rates of the two gamma emitting daughter products ^{214}Pb and ^{214}Bi :
 - 1) at least three hours shall be allowed to elapse between the end of the sampling period and the beginning of the gamma emission rate measurements;
 - 2) the emission rates are linked to the quantity of radon adsorbed;
- d) determining the average activity concentration from the gamma emission rates and the sampling period and by applying relevant calibration and correction factors.

After use, sensors should be sealed and not used again until a period of 1 month has elapsed. This ensures that any residual radon and short-lived daughters (^{214}Pb and ^{214}Bi) have decayed to levels which will not affect the results of the next measurement.

C.3 Equipment

The apparatus shall include the following:

- a) a measuring device containing a block of activated charcoal (sensor) which adsorbs radon and is used in an open or diffusion barrier configuration (see Figure C.1); in both configurations, the charcoal shall be retained in the base container by an open-mesh grille;
- b) a gamma spectrometer.

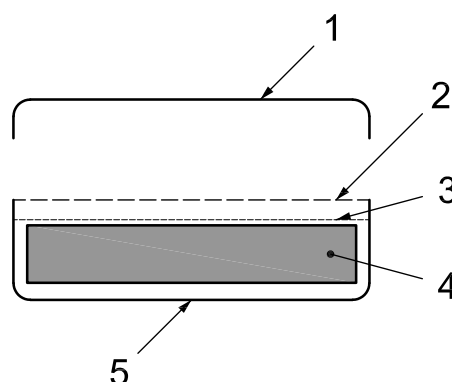

Keys

- 1 lid enabling hermetic seal with base container
- 2 diffusion barrier (optional)
- 3 open-mesh grille
- 4 activated charcoal
- 5 base container

Figure C.1 — Device using activated charcoal

In the open configuration, the charcoal is exposed directly to the atmosphere under investigation. In this condition, radon also desorbs from the charcoal when the concentration of radon in the surface layers of the charcoal is higher than that in the surrounding air. This makes the response of an open-faced activated

charcoal detector very sensitive to the time-profile of the radon activity concentration in the air to which it is exposed. Open-faced activated charcoal detectors have a response which is severely weighted towards the radon activity concentration at the end of the sampling period, whereas a response indicative of the average radon activity concentration over the entire sampling period is required. For this reason, open-faced activated charcoal detectors are generally only used over periods of up to 4 days.

In the diffusion barrier configuration, a diffusion barrier is placed between the activated charcoal and the atmosphere. This results in the radon activity concentration at the surface of the activated charcoal almost always being lower than that in the air being measured and the effects of radon desorption are greatly diminished. The presence of the diffusion barrier also reduces the amount of water vapour absorbed, and these devices can be used for exposure periods of over 7 days, even where the relative humidity is as high as 75 %.

A typical activated charcoal radon detector consists of a canister about 80 mm in diameter and 25 mm in height, with a total weight of about 100 g, that can be sent by mail to domestic users and returned to a laboratory within the prescribed time after exposure. The canister shall be sealed until received and then unsealed and exposed in the area to be measured. At the end of the sampling period, the canister shall be re-sealed and returned to the supplier, together with the dates and times the sampling started and finished, as well as an estimate of the average temperature during the sampling.

During the sampling period, radon is adsorbed onto the activated charcoal but it can also desorb from the surface as well. The activated charcoal will also absorb water vapour during the sampling period and this will reduce the capacity of the charcoal to adsorb radon. The radon adsorbed at the beginning of sampling will undergo more radioactive decay than that adsorbed towards the end of the measurement period. In order to take all of these factors into account, it is important that the calibration process be undertaken across a range of different relative humidity conditions and different sampling periods to enable appropriate correction factors to be generated. It is also important to understand that these correction factors apply to just a single batch of equal-weight detectors manufactured from the same material.

Figures C.2 and C.3 illustrate the variation in calibration factor with relative humidity (RH) and exposure time (sampling duration).

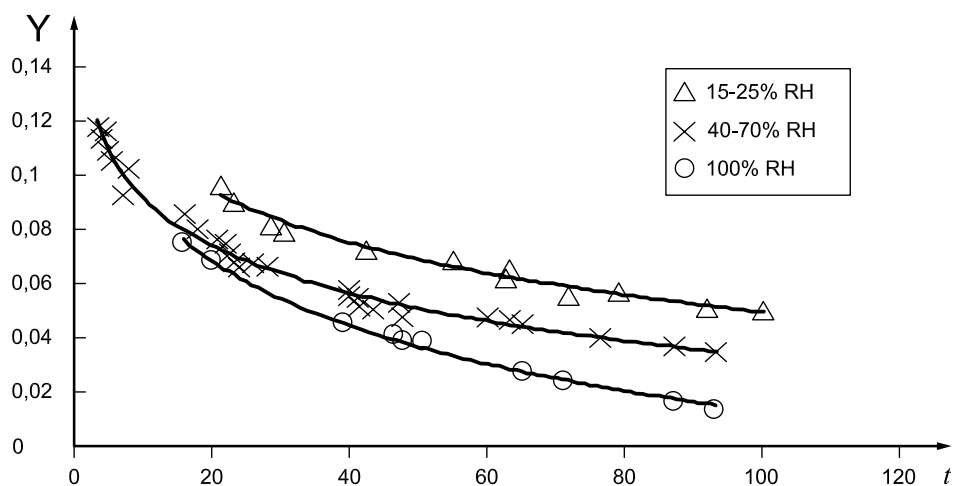

Key

- t exposure time, in hours (h)
- Y calibration factor (arbitrary units)

Figure C.2 — Variation of calibration factor with length of exposure time (sampling duration) and relative humidity (for illustrative purposes only)

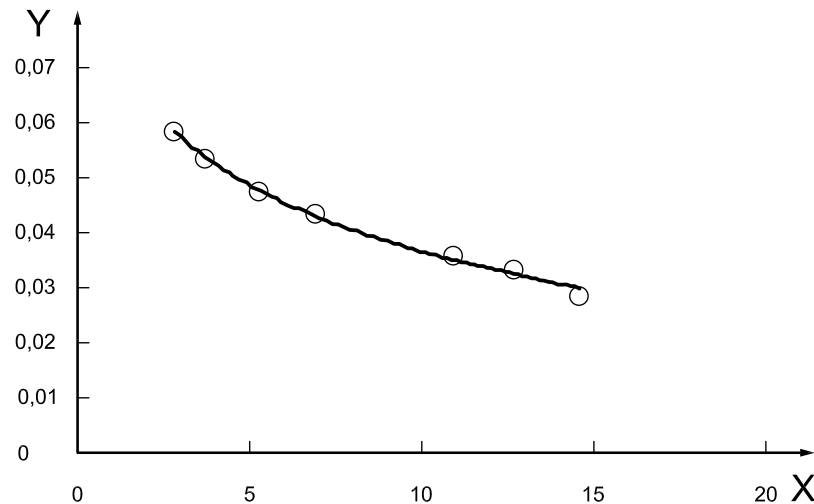

Key

- X absorbed water, in grams (g)
- Y calibration factor (arbitrary units)

Figure C.3 — Variation of calibration factor with mass of water absorbed during sampling period (for illustrative purposes only)

C.4 Sampling

Air sampling shall be passive.

The field detector shall be placed directly in the atmosphere under investigation.

Installation of the device shall be carried out in accordance with 6.3.2 and ISO 11665-1.

The lid shall be removed at the beginning of the sampling period, to expose the activated charcoal to the atmosphere being investigated. The time of opening shall be recorded. The lid shall be replaced at the end of the sampling period and the time recorded. Additional sealing may be achieved by applying adhesive tape around the seal between the lid and the base.

The sampling duration shall comply with 6.3.3.

C.5 Measurement

C.5.1 Procedure

C.5.1.1 Laboratory control detectors

The laboratory background level for each batch of devices should be established. A statistically significant number of unexposed devices should be assayed in an identical manner to the normal samples. The laboratory background level is subtracted from the results obtained from the normal exposed devices in order to determine the sample radon activity concentration.

C.5.1.2 Field control detectors

Field control detectors (field blanks) should consist of a minimum of 5 % of the devices that are deployed every month. The field control detectors should be sent to the sampling locations along with those which will be exposed. These should be kept sealed in a low radon (less than 10 Bq/m³) environment and returned with the normal sample devices. These control devices measure the background exposure that can accumulate

during shipment or storage, and results should be monitored and recorded. If one or a few of the field control detectors have radon activity concentrations that are significantly greater than the detection limit established by the supplier, it might indicate defective devices or poor procedures. If most of the controls have radon activity concentrations that are significantly greater than the detection limit, the average value of the field controls should be subtracted from the reported field detector activity concentrations rather than the laboratory background level, and the problem should be investigated.

C.5.1.3 Routine instrument checks

The counting equipment should be subject to routine checks to ensure proper operation. This is achieved by counting an instrument check source at least once each day that the instrument is in use. The count rate of the check source should be high enough to yield good counting statistics in a short time (for example, 1 000 to 10 000 counts per minute). A typical reference source would be a sealed radium source which enables the checking of the gamma spectrometer for energy calibration, gamma window and constancy of detection efficiency.

C.5.1.4 Field detectors

The device shall be sent to the laboratory as quickly as possible after the end of the sampling period. It shall be processed as soon as possible. The time between the end of sampling and the start of laboratory measurement shall not be less than 3 h, the time required for the ^{214}Pb and ^{214}Bi to reach secular equilibrium with the radon.

The device is measured in its entirety: the lid is not removed but any adhesive tape [as applied in accordance with C.2 a) 5) and C.4] shall be removed.

Before the gamma spectrometer measurements are started, the field detector is weighed. The difference in weight between this measurement and that determined in C.2 a) 4) is equal to the weight of water absorbed during the sampling period and is used to apply an appropriate correction factor.

The gamma energy window, sample position and sample configuration used for counting with the gamma spectrometer shall be the same as those used for calibration.

The gamma energy window used for the gamma spectrometer measurements shall be set to include the photon energies of the principal gammas from the ^{214}Pb and ^{214}Bi , namely 295 keV, 352 keV and 609 keV. Because these decay products are in secular equilibrium with the radon, the activity concentration of these decay products will be equal to the radon activity concentration.

C.5.2 Influence quantities

Besides the influence quantities specified in IEC 61577-1 and ISO 11665-1, the humidity shall also be taken into account. The absorption of water vapour on the surfaces of the activated charcoal reduces the sites available for the absorption of radon, and corrections need to be applied to compensate for the amount of water absorbed during the sampling period.

Manufacturer recommendations in the operating instructions for the measuring devices shall be respected.

C.5.3 Calibration

Each batch of detectors shall be calibrated upon receipt if the calibration factor is not provided by manufacturer.

For a batch of detectors, calibration involves exposing each device to reference atmospheres. The humidity of the reference atmosphere shall be recorded. The devices should be prepared and sealed in the same manner as that used for normal sampling, including sealing before return to the laboratory.

The exposed devices shall then be assayed by the same gamma spectrometer, using the same gamma window as used for normal samples. The devices are placed in the same position, with the same orientation as those used for normal samples.

The ratio between the number of photons accumulated in the gamma window per unit time and the reference radon activity concentration is the calibration factor (s^{-1} per Bq/m^3).

Corrections shall be applied to take into account the decay from the mid-time of the sampling period to the mid-time of the gamma spectrometer measurement (this assumes that the period of the gamma spectrometer measurement is less than 10 h).

Because the radon adsorbed is constantly decaying, the calibration factor will vary according to the total sampling duration. If accurate results are required, it is essential to determine calibration factors across a range of sampling durations and to produce an appropriate correction table.

The adsorption efficiency is dependent on the humidity of the atmosphere being sampled, and the calibration factor that is determined is that for the humidity of the reference atmosphere. Correction factors should be developed to enable measurement results to be normalized to the humidity at which the calibration factor was determined. These correction factors should be expressed as the correction to be applied for the increase in weight calculated in C.5.1.4.

It is recommended that all devices be calibrated on a regular basis (e.g. every one or two years).

The variations in the calibration factor arising from the effects of relative humidity and the sampling duration are often aggregated into a correction table. Table C.1 is an example of a typical table.

Table C.1 — Corrections to calibration factors for a 100 g detector arising from variations in relative humidity (measured by mass of water absorbed during the sampling duration) and for different sampling durations (for illustrative purposes only)

Change in mass of detector during sampling duration	Sampling duration	Correction
< 1 g	48 h	0,92
	72 h	0,87
1 g to 4 g	48 h	1
	72 h	1
> 4 g	48 h	1,25
	72 h	1,54

C.6 Expression of results

C.6.1 General

For further information on the following calculations, see ISO 18589-3, for example.

C.6.2 Average radon activity concentration

The average radon activity concentration is obtained from Formula (1). This yields Formula (C.1):

$$\bar{C} = \left(\frac{n_N}{t_g} - \frac{n_{NO}}{t_0} \right) \frac{f_H \cdot f_S \cdot f_d}{F_c} = \left(\frac{n_N}{t_g} - \frac{n_{NO}}{t_0} \right) \cdot \omega \quad \text{with} \quad \omega = \frac{f_H \cdot f_S \cdot f_d}{F_c} \quad (\text{C.1})$$

where

$$f_d^{-1} = e^{\lambda \cdot t_i} \cdot \left(\frac{\lambda \cdot t_g}{1 - e^{-\lambda \cdot t_g}} \right)$$

C.6.3 Standard uncertainty

The standard uncertainty of \bar{C} is obtained from Formula (2). This yields Formula (C.2):

$$u(\bar{C}) = \sqrt{\omega^2 \cdot \left[\frac{u^2(n_N)}{t_g^2} + \frac{u^2(n_{N0})}{t_0^2} \right] + (\bar{C})^2 \cdot u_{\text{rel}}^2(\omega)} \quad (\text{C.2})$$

where the uncertainty of the counting duration is considered negligible.

n_N , n_{N0} , $u^2(n_N)$ and $u^2(n_{N0})$ follow the expressions:

$$n_N = n_g - n_b \quad \text{and} \quad n_{N0} = n_{g0} - n_{b0}$$

$$u^2(n_N) = u^2(n_g) + u^2(n_b) \quad \text{and} \quad u^2(n_{N0}) = u^2(n_{g0}) + u^2(n_{b0}), \quad \text{respectively.}$$

The values of n_N , n_g and n_b and their associated standard uncertainties can be calculated with a computer program. Since there are various methods of subtracting the background below a peak in order to derive the number of counts in the net peak area, no generally applicable equation can be given for the uncertainties. An example of the simple case of linear background subtraction is given in ISO 18589-3:2007, Annex A.

The relative standard uncertainty of ω is calculated as given by Formula (C.3):

$$u_{\text{rel}}^2(\omega) = u_{\text{rel}}^2(F_c) + u_{\text{rel}}^2(f_H) + u_{\text{rel}}^2(f_s) + u_{\text{rel}}^2(f_d) \quad (\text{C.3})$$

C.6.4 Decision threshold

The decision threshold, \bar{C}^* , is obtained in accordance with ISO 11929. This yields Formula (C.4):

$$\bar{C}^* = k_{1-\alpha} \cdot \omega \cdot \sqrt{\left[n_b + u^2(n_b) \right] / t_g^2 + \left[n_{g0} + u^2(n_{b0}) \right] / t_0^2 + (n_{g0} - n_{b0}) / t_0 \cdot t_g} \quad (\text{C.4})$$

where $\alpha = 0,05$ with $k_{1-\alpha} = 1,65$ is often chosen by default.

C.6.5 Detection limit

The detection limit, $\bar{C}^\#$, is calculated in accordance with ISO 11929. This yields Formula (C.5):

$$\bar{C}^\# = \bar{C}^* + k_{1-\alpha} \cdot \omega \cdot \sqrt{\bar{C}^\# / t_g \cdot \omega + \left[n_b + u^2(n_b) \right] / t_g^2 + \left[n_{g0} + u^2(n_{b0}) \right] / t_0^2 + (n_{g0} - n_{b0}) / t_0 \cdot t_g + \bar{C}^{\#2} \cdot u_{\text{rel}}^2(\omega)} \quad (\text{C.5})$$

The detection limit can be calculated by solving Formula (C.5) for $\bar{C}^\#$ or, more simply, by iteration with a starting approximation of $\bar{C}^\# = 2 \cdot \bar{C}^*$ in terms of the right side of Formula (C.5).

One obtains $\bar{C}^\#$ with $k_{1-\alpha} = k_{1-\beta} = k$:

$$\bar{C}^\# = \frac{2 \cdot \bar{C}^* + (k^2 \cdot \omega) / t_g}{1 - k^2 \cdot u_{\text{rel}}^2(\omega)} \quad (\text{C.6})$$

Values $\alpha = \beta = 0,05$ and therefore $k_{1-\alpha} = k_{1-\beta} = 1,65$ are often chosen by default.

C.6.6 Example

This subclause provides a numerical example for a 100 g detector exposed for a sampling duration of 72 h.

A calibration factor, F_C , determined for 5 g mass gain and 72 h sampling during a calibration programme is equal to $0,097\ 2\ \text{s}^{-1}/\text{Bq}/\text{m}^3$.

The relative standard uncertainty of the calibration factor determined during the calibration programme is equal to 7 %.

The mass gain during sampling is equal to 3 g.

The standard uncertainty of the mass gain is equal to 0,2 g.

The correction to the calibration factor for 3 g mass gain is equal to 18 % ($f_H = 1,18$).

The time between the mid-point of sampling and measurement of the exposed detector, t_{sm} , is equal to 48 h.

The standard uncertainty of t_{sm} is negligible.

The gamma spectrometer counting duration, t_g , is equal to 600 s.

The standard uncertainty of t_g is negligible.

The difference between the sampling duration and the reference calibration exposure period is equal to 0.

The total number of counts accumulated over 600 s in the gamma spectrometer window is equal to 18 000.

The background total number of counts accumulated over 600 s in the gamma spectrometer window is equal to 1 500.

$t_g = t_0 = 600\ \text{s}$ and $n_N = 18\ 000$ and $n_{N0} = 1\ 500$.

Thus, the average radon activity concentration, calculated from Formula (C.1), is:

$$\bar{C} = 436\ \text{Bq}/\text{m}^3$$

The standard uncertainty of the average radon activity concentration is calculated from Formula (C.2):

$$u(\bar{C}) = 43\ \text{Bq}/\text{m}^3$$

where uncertainty of the humidity correction arises from uncertainty of the mass gain, therefore:

$$u_{\text{rel}}(f_H) = 0,2/0,03 = 0,067 \quad \text{and} \quad u_{\text{rel}}^2(\omega) = (0,07)^2 + (0,067)^2$$

Thus, the average radon activity concentration is:

$$\bar{C} = (436 \pm 43)\ \text{Bq}/\text{m}^3$$

The decision threshold, \bar{C}^* , is obtained from Formula (C.4):

$$\bar{C}^* = k_{1-\alpha} \cdot \tilde{u}(0) = 3\ \text{Bq}/\text{m}^3$$

The detection limit, $\bar{C}^\#$, is calculated by Formula (C.6):

$$\bar{C}^\# = 6\ \text{Bq}/\text{m}^3$$

Bibliography

- [1] Nuclear Data Base issued from the Decay Data Evaluation Project. Available at: http://www.nucleide.org/DDEP_WG/DDEPdata.htm
- [2] UNSCEAR 2006 Report: *Effects of ionizing radiation* (Vol. 1, report to the General Assembly and two scientific annexes). United Nations Publication, New York, 2008
- [3] ICRP Publication 65. Protection against radon-222 at home and at work. *Annals of the ICRP*, **23** (2), 1993
- [4] Joint DGS and DGUHC circular No. 99/46 of 27 January 1999 on the organisation of radon-linked risk management
- [5] DGS circular No. 2001/303 of 2 July 2001 on radon-linked risk management in buildings open to the public
- [6] Institut de Protection et de Sûreté Nucléaire — Direction Générale de la Santé. Campagne nationale de mesure de l'exposition domestique au radon. Bilan et représentation cartographique des mesures au 1 janvier 2000
- [7] ICRP Sampling sheet, GTI.4, No. 33. *Prélèvement sur filtre des matières particulaires en suspension dans l'air ambiant en vue de la détermination de leur radioactivité*. Ref. GTI.4/AQ/FP/068, May 1989
- [8] SCHMIDT, V., FEDDERSEN, C., ULLMANN, W. *Untersuchungen zur Aussagefähigkeit von passiven Messsystemen zur Bestimmung der Strahlenexposition durch Radon und kurzlebige Radonzerfallsprodukte*. BfS-ST-Berichte, BfS-ST-6/95, 1995
- [9] SCHMIDT V. *Measurements of deposition velocities and particle concentrations of unattached radon decay products at locations near surfaces*. Proceedings of the 5th International Conference on High Levels of Natural Radiation and Radon Areas, Munich, Germany, 4 to 7 September 2000, Vol. 2
- [10] KOTRAPPA P., DEMPSEY J.C., RAMSEY W., STIEFF L.R. A practical E-PERM™ (Electret Passive Environmental Radon Monitor) system for indoor ²²²Rn measurement. *Health Phys.*, **58** (4), 1990, pp. 461–467
- [11] ISO/IEC Guide 98-3, *Uncertainty of measurement — Part 3: Guide to the expression of uncertainty in measurement (GUM: 1995)*
- [12] ISO 11665-8¹⁾, *Measurement of radioactivity in the environment — Air: radon-222 — Part 8: Methodologies for initial and additional investigations in buildings*
- [13] ISO 18589-3:2007, *Measurement of radioactivity in the environment — Soil — Part 3: Measurement of gamma-emitting radionuclides*
- [14] IEC 61577-2, *Radiation protection instrumentation — Radon and radon decay product measuring instruments — Part 2: Specific requirements for radon measuring instruments*

1) To be published.

British Standards Institution (BSI)

BSI is the national body responsible for preparing British Standards and other standards-related publications, information and services.

BSI is incorporated by Royal Charter. British Standards and other standardization products are published by BSI Standards Limited.

About us

We bring together business, industry, government, consumers, innovators and others to shape their combined experience and expertise into standards-based solutions.

The knowledge embodied in our standards has been carefully assembled in a dependable format and refined through our open consultation process. Organizations of all sizes and across all sectors choose standards to help them achieve their goals.

Information on standards

We can provide you with the knowledge that your organization needs to succeed. Find out more about British Standards by visiting our website at bsigroup.com/standards or contacting our Customer Services team or Knowledge Centre.

Buying standards

You can buy and download PDF versions of BSI publications, including British and adopted European and international standards, through our website at bsigroup.com/shop, where hard copies can also be purchased.

If you need international and foreign standards from other Standards Development Organizations, hard copies can be ordered from our Customer Services team.

Subscriptions

Our range of subscription services are designed to make using standards easier for you. For further information on our subscription products go to bsigroup.com/subscriptions.

With **British Standards Online (BSOL)** you'll have instant access to over 55,000 British and adopted European and international standards from your desktop. It's available 24/7 and is refreshed daily so you'll always be up to date.

You can keep in touch with standards developments and receive substantial discounts on the purchase price of standards, both in single copy and subscription format, by becoming a **BSI Subscribing Member**.

PLUS is an updating service exclusive to BSI Subscribing Members. You will automatically receive the latest hard copy of your standards when they're revised or replaced.

To find out more about becoming a BSI Subscribing Member and the benefits of membership, please visit bsigroup.com/shop.

With a **Multi-User Network Licence (MUNL)** you are able to host standards publications on your intranet. Licences can cover as few or as many users as you wish. With updates supplied as soon as they're available, you can be sure your documentation is current. For further information, email bsmusales@bsigroup.com.

BSI Group Headquarters

389 Chiswick High Road London W4 4AL UK

Revisions

Our British Standards and other publications are updated by amendment or revision.

We continually improve the quality of our products and services to benefit your business. If you find an inaccuracy or ambiguity within a British Standard or other BSI publication please inform the Knowledge Centre.

Copyright

All the data, software and documentation set out in all British Standards and other BSI publications are the property of and copyrighted by BSI, or some person or entity that owns copyright in the information used (such as the international standardization bodies) and has formally licensed such information to BSI for commercial publication and use. Except as permitted under the Copyright, Designs and Patents Act 1988 no extract may be reproduced, stored in a retrieval system or transmitted in any form or by any means – electronic, photocopying, recording or otherwise – without prior written permission from BSI. Details and advice can be obtained from the Copyright & Licensing Department.

Useful Contacts:

Customer Services

Tel: +44 845 086 9001

Email (orders): orders@bsigroup.com

Email (enquiries): cservices@bsigroup.com

Subscriptions

Tel: +44 845 086 9001

Email: subscriptions@bsigroup.com

Knowledge Centre

Tel: +44 20 8996 7004

Email: knowledgecentre@bsigroup.com

Copyright & Licensing

Tel: +44 20 8996 7070

Email: copyright@bsigroup.com



...making excellence a habit.™