

Statistical aspects of sampling from bulk materials —

Part 2: Sampling of particulate materials

ICS 03.120.30

National foreword

This British Standard reproduces verbatim ISO 11648-2:2001 and implements it as the UK national standard.

The UK participation in its preparation was entrusted to Technical Committee SS/3, Application of Statistical Methods, which has the responsibility to:

- aid enquirers to understand the text;
- present to the responsible international/European committee any enquiries on the interpretation, or proposals for change, and keep the UK interests informed;
- monitor related international and European developments and promulgate them in the UK.

A list of organizations represented on this committee can be obtained on request to its secretary.

Textual errors

The textual error set out below was discovered when adopting the text of the international standard. It has been reported to ISO in a proposal to amend the text of the international standard.

Clause 5.3.2, page 17, paragraph 2 is not correct. An effect does not have to be statistically significant before it can be accommodated.

Cross-references

The British Standards which implement international or European publications referred to in this document may be found in the BSI Standards Catalogue under the section entitled "International Standards Correspondence Index", or by using the "Find" facility of the BSI Standards Electronic Catalogue.

A British Standard does not purport to include all the necessary provisions of a contract. Users of British Standards are responsible for their correct application.

Compliance with a British Standard does not of itself confer immunity from legal obligations.

Any further errors in this standard should be submitted to the Secretary of the Technical committee SS/3, British Standards House, 389 Chiswick High Road, W4 4AL who will submit them formally to ISO.

This British Standard, having been prepared under the direction of the Management Systems Sector Policy and Strategy Committee, was published under the authority of the Standards Policy and Strategy Committee on 5 December 2001

Summary of pages

This document comprises a front cover, an inside front cover, ISO title page, pages ii to v, a blank page, pages 1 to 102, an inside back cover and a back cover.

The BSI copyright date displayed in this document indicates when the document was last issued.

Amendments issued since publication

Amd. No.	Date	Comments

**Statistical aspects of sampling from bulk
materials —**

Part 2:
Sampling of particulate materials

*Aspects statistiques de l'échantillonnage des matériaux en vrac —
Partie 2: Échantillonnage des matériaux particulaires*



Contents		Page
Foreword.....		iv
Introduction		v
1 Scope		1
2 Normative references		2
3 Terms, definitions and symbols		2
4 Applications of bulk material sampling		12
5 Principles of sampling		13
6 Establishing a sampling scheme		23
7 Mass of increment and minimization of bias		29
8 Number of increments		32
9 Masses of gross samples and sub-lot samples		34
10 Mass-basis sampling		40
11 Time-basis sampling		42
12 Stratified random sampling within fixed mass or time intervals		44
13 Mechanical sampling from moving streams		44
14 Manual sampling from moving streams		50
15 Stopped-belt sampling		51
16 Sampling from stationary situations		52
17 Principles of sample preparation		59
18 Precision of sample preparation		67
19 Bias in sample preparation		67
20 Preparation of samples for the determination of moisture		69
21 Preparation of samples for chemical analysis		71
22 Preparation of samples for physical testing		72
23 Precision and bias of measurement		72
24 Packing and marking of samples		73
Annex A (informative) Examples of variance calculations		74
Annex B (informative) Mechanical sampling implements		79
Annex C (informative) Manual sampling implements form moving streams		84
Annex D (informative) Sampling implements for stationary situations		86
Annex E (informative) Sample preparation schemes		89
Annex F (informative) Particle-size reduction equipment		91
Annex G (informative) Examples of mechanical mixers		94
Annex H (informative) Mechanical sample dividers		96
Annex I (informative) Implements for manual sample division		99
Annex J (informative) Examples of riffles		101
Bibliography		102

Foreword

ISO (the International Organization for Standardization) is a worldwide federation of national standards bodies (ISO member bodies). The work of preparing International Standards is normally carried out through ISO technical committees. Each member body interested in a subject for which a technical committee has been established has the right to be represented on that committee. International organizations, governmental and non-governmental, in liaison with ISO, also take part in the work. ISO collaborates closely with the International Electrotechnical Commission (IEC) on all matters of electrotechnical standardization.

International Standards are drafted in accordance with the rules given in the ISO/IEC Directives, Part 3.

Draft International Standards adopted by the technical committees are circulated to the member bodies for voting. Publication as an International Standard requires approval by at least 75 % of the member bodies casting a vote.

Attention is drawn to the possibility that some of the elements of this part of ISO 11648 may be the subject of patent rights. ISO shall not be held responsible for identifying any or all such patent rights.

International Standard ISO 11648-2 was prepared by Technical Committee ISO/TC 69, *Applications of statistical methods*, Subcommittee SC 3, *Application of statistical methods in standardization*.

ISO 11648 consists of the following parts, under the general title *Statistical aspects of sampling from bulk materials*:

- *Part 1: General principles*
- *Part 2: Sampling of particulate materials*

It is the intention of ISO/TC 69/SC 3 to develop additional parts to ISO 11648 to cover the sampling of liquids and gases, if the need exists.

Annexes A to J of this part of ISO 11648 are for information only.

Introduction

This part of ISO 11648 gives the basic methods for sampling bulk particulate materials in bulk (e.g. ores, mineral concentrates, coal, industrial chemicals in powder and granular form, and agricultural products such as grain) from moving streams and stationary situations.

Part 1 of ISO 11648 gives a broad outline of the statistical aspects of sampling from bulk materials.

Statistical aspects of sampling from bulk materials —

Part 2: Sampling of particulate materials

1 Scope

This part of ISO 11648 establishes the basic methods for sampling particulate materials in bulk (e.g. ores, mineral concentrates, coal, industrial chemicals in powder or granular form, and agricultural products such as grain) from moving streams and stationary situations, including stopped-belt sampling, to provide samples for measuring one or more variables in an unbiased manner and with a known degree of precision. The variables are measured by chemical analysis and/or physical testing. These sampling methods are applicable to materials that require inspection to verify compliance with product specifications or contract settlements, to calculate the value of the lot mean of a measurable quantity as a basis for settlement between trading partners, or to estimate the set of variables and variances that describes a system or procedure.

Stopped-belt sampling is the reference method against which other sampling procedures are compared. Dynamic sampling from moving streams is the preferred method whereby a sampling device (called a cutter) is passed through the stream of the particulate material. A complete cross-section of the moving stream can be removed as a primary increment at a conveyor belt transfer point with a falling-stream cutter, or removed from the belt with a cross-belt cutter. In both cases, the selection and extraction of increments can be described by a one-dimensional dynamic sampling model.

Static sampling of bulk material from stationary situations, such as stockpiles, rail or road wagons, the holds of ships and barges, silos, and even comparatively small volumes, is used only where sampling from moving streams is not possible. Such sampling from three-dimensional lots is prone to systematic errors, because some parts of the lot usually have reduced or no chance of being collected for the gross sample. This is in violation of the requirement of the three-dimensional sampling model that all parts have an equal probability of being collected. The procedures described in this part of ISO 11648 for sampling from stationary lots of bulk particulate material with implements such as mechanical augers merely minimize some of the systematic sampling errors.

For these reasons, this part of ISO 11648 is primarily concerned with dynamic sampling from moving streams or stopped-belt static sampling from conveyor belts and is based on a sampling model for one-dimensional lots. Nonetheless, procedures for static sampling from three-dimensional lots are provided where these situations cannot be avoided.

This part of ISO 11648 is concerned with the methods of sampling particulate materials in bulk with the objective of obtaining unbiased measurements of one or more variables of the material with a known degree of precision. However, it does not provide methods for deciding whether to accept or reject a bulk material lot with specified degrees of risk of accepting a sub-standard lot, or of rejecting what is in fact an acceptable lot. These latter procedures are usually called acceptance sampling or sampling inspection methods.

2 Normative references

The following normative documents contain provisions which, through reference in this text, constitute provisions of this part of ISO 11648. For dated references, subsequent amendments to, or revisions of, any of these publications do not apply. However, parties to agreements based on this part of ISO 11648 are encouraged to investigate the possibility of applying the most recent editions of the normative documents indicated below. For undated references, the latest edition of the normative document referred to applies. Members of ISO and IEC maintain registers of currently valid International Standards.

ISO 565, *Test sieves — Metal wire cloth, perforated metal plate and electroformed sheet — Nominal sizes of openings.*

ISO 3084, *Iron ores — Experimental methods for evaluation of quality variation.*

ISO 3085, *Iron ores — Experimental methods for checking the precision of sampling.*

ISO 3086, *Iron ores — Experimental methods for checking the bias of sampling.*

ISO 3534 (all parts), *Statistics — Vocabulary and symbols.*

ISO 5725-1, *Accuracy (trueness and precision) of measurement methods and results — Part 1: General principles and definitions.*

ISO 5725-2, *Accuracy (trueness and precision) of measurement methods and results — Part 2: Basic method for the determination of repeatability and reproducibility of a standard measurement method.*

ISO 5725-3, *Accuracy (trueness and precision) of measurement methods and results — Part 3: Intermediate measures of the precision of a standard measurement method.*

ISO 5725-4, *Accuracy (trueness and precision) of measurement methods and results — Part 4: Basic methods for the determination of the trueness of a standard measurement method.*

ISO 5725-6, *Accuracy (trueness and precision) of measurement methods and results — Part 6: Use in practice of accuracy values.*

ISO 11648-1:—¹⁾, *Statistical aspects of sampling from bulk materials — Part 1: General principles.*

ISO 13909-7:—¹⁾, *Hard coal and coke — Mechanical sampling — Part 7: Methods for determining the precision of sampling, sample preparation and testing.*

ISO 13909-8:—¹⁾, *Hard coal and coke — Mechanical sampling — Part 8: Methods of testing for bias.*

Guide to the expression of uncertainty in measurement (GUM). BIPM, IEC, IFCC, ISO, IUPAC, IUPAP, OIML, 1st edition, 1995.

3 Terms, definitions and symbols

3.1 Terms and definitions

For the purpose of this part of ISO 11648, the terms and definitions of ISO 3534 (all parts) and the following (taken from the current draft revision of ISO 3534-2) apply.

NOTE The text <bulk material> shown after terms means the definition given is confined to the field of bulk material sampling.

¹⁾ To be published.

3.1.1**bulk material**

amount of material within which component parts are not initially distinguishable on the macroscopic level

3.1.2**sample**

⟨bulk material⟩ subset of a specified population made up of one or more sampling units

3.1.3**sampling**

act of drawing or constituting a sample

3.1.4**simple random sampling**

sampling where a sample of n sampling units is taken from a population in such a way that all combinations of n sampling units have the same probability of being taken

NOTE In bulk material sampling, if the sampling unit is an increment, the positioning, delimitation and extraction of increments should ensure that all sampling units have an equal probability of being selected.

3.1.5**stratum**

mutually exclusive and exhaustive sub-population considered to be more homogeneous with respect to the characteristic investigated than the total population

EXAMPLES In bulk material, strata, based on time, mass and space, are typically production periods (e.g. 15 min), production masses (e.g. 100 t), holds in vessels, wagons in a train, or containers.

3.1.6**stratified sampling**

sampling such that portions of the sample are drawn from the different strata and each stratum is sampled with at least one sampling unit

NOTE In some cases, the portions are specified proportions determined in advance. However, in post-stratified sampling, the specified proportions would not be known in advance.

3.1.7**stratified simple random sampling**

simple random sampling from each stratum

3.1.8**systematic sampling**

sampling according to a methodical scheme

NOTE 1 In bulk sampling, systematic sampling may be achieved by taking items at fixed distances or after time intervals of fixed length. Intervals may, for example, be on a mass or time basis. In the case of a mass basis, sampling units or increments should be of equal mass. With respect to a time basis, sampling units or increments should be taken from a moving stream or conveyor, for example, at uniform time intervals. In this case, the mass of each sampling unit or increment should be proportional to the mass flow rate at the instant of taking the entity or increment.

NOTE 2 If the lot is divided into strata, stratified systematic sampling can be carried out by taking increments at the same relative locations within each stratum.

3.1.9**sampling unit**

⟨bulk material⟩ one of the member parts, each with equal probability of selection in sampling, into which a population, comprised of the total quantity of bulk material under consideration, is divided

NOTE 1 In bulk sampling, the operative characteristics of the sampling unit are that the probability of selection of all sampling units should be equal and that the entire sampling unit becomes part of the sample when it is selected.

NOTE 2 When sampling from a bulk material is performed by extraction of individual increments, the sampling unit is the primary increment.

3.1.10

precision

closeness of agreement between independent test results obtained under stipulated conditions

NOTE 1 Precision depends only on the distribution of random errors and does not relate to the true value or the specified value.

NOTE 2 The measure of precision is usually expressed in terms of imprecision and computed as a standard deviation of the test result. Less precision is reflected by a larger standard deviation.

NOTE 3 Quantitative measures of precision depend critically on the stipulated conditions. Repeatability and reproducibility conditions are particular sets of extreme stipulated conditions.

3.1.11

bias

difference between the expectation of a test result and an accepted reference value

NOTE 1 Bias is the total systematic error as contrasted to random error. There may be one or more systematic error components contributing to the bias. A larger systematic difference from the accepted reference value is reflected by a larger bias value.

NOTE 2 The bias of a measurement instrument is normally estimated by averaging the error of indication over an appropriate number of repeated measurements. In this case, the error of indication is the

“indication of a measuring instrument minus a true value of the corresponding input quantity”.

3.1.12

lot

⟨bulk material⟩ definite part of a population, comprised of the total quantity of bulk material under consideration, and where this part is considered as a quantity of material for which specific characteristics are to be determined

NOTE Commerce in bulk material often encompasses transactions involving single lots, and, in these cases, the lot becomes the population.

3.1.13

sub-lot

⟨bulk material⟩ definite part of a lot of bulk material

3.1.14

increment

⟨bulk material⟩ quantity of bulk material taken in one action by a sampling device

NOTE 1 The positioning, delimitation and extraction of the increment should ensure that all parts of the bulk material in the lot have an equal probability of being selected.

NOTE 2 Sampling is often carried out in progressive mechanical stages, in which case it is necessary to distinguish between a primary increment which is a sampling unit that is extracted from the lot at the first sampling stage, and a secondary increment which is extracted from the primary increment at the secondary sampling stage, and so on.

3.1.15

composite sample

⟨bulk material⟩ aggregation of two or more increments taken from a lot

3.1.16

gross sample

⟨bulk material⟩ aggregation of all the increments taken from a sub-lot or lot by the procedures of routine sampling

3.1.17

test sample

⟨bulk material⟩ sample, as prepared for testing or analysis, the whole quantity or a part of it being used for testing or analysis at one time

NOTE The term may be used in such ways as “test sample for chemical analysis”, “test sample for moisture determination”, “test sample for particle size determination” and “test sample for physical testing”.

3.1.18

test portion

⟨bulk material⟩ part of a test sample which is used for analysis or testing at one time

3.1.19

multi-stage sampling

⟨bulk material⟩ sampling in which the sample is selected by stages, the sampling units at each stage being sampled from the larger sampling units chosen at the previous stage

3.1.20

routine sampling

⟨bulk material⟩ sampling for commercial purposes carried out by the stipulated procedures in the specific International Standard in order to determine the average quality of the lot

NOTE The term “regular sampling” is sometimes used as an alternative to “routine sampling”.

3.1.21

experimental sampling

⟨bulk material⟩ non-routine sampling where special purpose experimental design is applied to investigate sources of variance and/or sampling bias

3.1.22

interpenetrating sampling

⟨bulk material⟩ replicate sampling from several lots or sub-lots, where for each lot i or sub-lot i , consecutive primary increments are diverted in rotation into different containers to give multiple composite samples (A_i, B_i, C_i, \dots) in order to investigate the variance between the increments in the lot or the sub-lot

NOTE 1 The term “interleaved sampling” is sometimes used as an alternative to “interpenetrating sampling”.

NOTE 2 Most interpenetrating sampling schemes use a duplicate sampling method with composite sample pairs (A_i, B_i) being constituted for each lot i or sub-lot i .

3.1.23

replicate sampling

⟨bulk material⟩ sampling where increments are taken simultaneously or consecutively in pairs in order to constitute multiple composite samples

3.1.24

duplicate sampling

⟨bulk material⟩ replicate sampling where increments are taken simultaneously or consecutively in pairs in order to constitute two composite samples

NOTE Duplicate sampling is a special case of replicate sampling.

3.1.25

manual sampling

⟨bulk material⟩ collection of increments by human effort

3.1.26

mechanical sampling

⟨bulk material⟩ collection of increments by mechanical means

3.1.27

cut

⟨bulk material⟩ single traverse of the sample cutter, in mechanical sampling, through the stream

**3.1.28
sample preparation**

⟨bulk material⟩ set of material operations necessary to transform a sample into a test sample

EXAMPLE Reduction of sizes, mixing and dividing.

NOTE For particulate materials, the completion of each operation of sample division defines the commencement of the next sample preparation stage. Thus the number of stages in sample preparation is equal to the number of divisions made.

**3.1.29
sample reduction**

⟨bulk material⟩ process in sample preparation whereby the particle size is reduced by crushing, grinding or pulverization

**3.1.30
sample division**

⟨bulk material⟩ process in sample preparation whereby a sample of a bulk material is divided by such means as riffing, mechanical division, or quartering into separate parts, one or more of which is retained

EXAMPLE Riffing, mechanical division or quartering.

**3.1.31
fixed ratio division**

⟨bulk material⟩ sample division in which the retained parts from individual samples are a constant proportion of the original

**3.1.32
fixed mass division**

⟨bulk material⟩ sample division in which the retained divided parts are of almost uniform mass, irrespective of variations in mass of the samples being divided

**3.1.33
sample drying**

⟨bulk material⟩ process in sample preparation of partial drying of the sample to bring its moisture content near to a level which will not bias the results of further testing or sample preparation

**3.1.34
routine sample preparation**

⟨bulk material⟩ sample preparation carried out by the stipulated procedures in the specific International Standard in order to determine the average quality of the lot

**3.1.35
non-routine sample preparation**

⟨bulk material⟩ sample preparation carried out for experimental sampling

**3.1.36
nominal top size**

⟨bulk material⟩ particle size expressed by the aperture dimension of the test sieve (from a square hole sieve series complying with ISO 565) on which no more than 5 % of the sample is retained

**3.1.37
nominal bottom size**

⟨bulk material⟩ particle size expressed by the aperture dimension of the test sieve (from a square hole sieve series complying with ISO 565) through which no more than 5 % of the sample passes

**3.1.38
quality variation**

⟨bulk material⟩ standard deviation of the quality characteristics determined either by estimating the variance between interpenetrating samples taken from the lot or sub-lot, or by estimating the variance from a variographic analysis of the differences between individual increments separated by various lagged intervals

3.1.39**sampling procedure**

⟨bulk material⟩ operational requirements and/or instructions relating to taking increments and constituting a sample

3.1.40**sample preparation procedure**

⟨bulk material⟩ operational requirements and/or instructions relating to methods and criteria for sample division

3.1.41**sampling scheme**

⟨bulk material⟩ specification of the type of sampling to be used combined with the operational specification of the entities or increments to be taken, the samples to be constituted and the measurements to be made

EXAMPLE The scheme may specify, for example, that the sampling shall be systematic and in two stages. In combination with the specification of the type of sampling, the scheme, in this example, also may specify the number of increments to be taken from a lot, the number of composite samples (or gross samples) per lot, the number of test samples per composite sample, and the number of measurements per test sample.

3.1.42**sampling system**

⟨bulk material⟩ operational mechanism and/or mechanical installation for taking increments and sample preparation

3.2 Symbols

A list of symbols used in this part of ISO 11648 is presented in Table 1 with short descriptions of symbol meanings and references to the subclauses where the symbols are first mentioned. Table 2 gives a list of subscripts with their meanings that are used in this part of ISO 11648.

Table 1 — Symbols

Symbol	Meaning	Units	First mention
A_{cor}	random component of variance of the corrected variogram and equal to its intercept	—	5.3.2
A_{der}	derived variogram intercept for the increment mass to be used for sampling	—	8.2.2
A_F	constant used to calculate the fundamental error component of the variogram intercept and with the units of a density	kg/mm ³ or kg/m ³ × 10 ⁻⁹	5.3.2
A_0	constant derived from a least squares fit to between-sample variance data	—	9.2.2
a_i	measurement of the quality characteristic of the test sample prepared from sub-lot sample A_i	—	5.3.3
B	gradient (i.e. slope) of variogram, for mass-basis sampling, or for time-basis sampling	min ⁻¹ (time) t ⁻¹ (mass)	5.3.2
b	effective aperture width of cutter	mm	13.3.4
b_i	measurement of the quality characteristic of the test sample prepared from sub-lot sample B_i	—	5.3.3

Table 1 — Symbols (continued)

Symbol	Meaning	Units	First mention
b_{\min}	minimum cutting aperture width	m	7.2
d	nominal top size of particles	mm	5.3.2
d_L	lower size limit and defined as the finest sieve aperture width that passes 5 % of the undersized particles	mm	9.2.3
d_λ	nominal top size at which complete liberation occurs	mm	9.2.3
e_{del}	increment-delimitation error	—	5.2.1
e_E	increment-extraction error	—	5.2.1
e_F	fundamental error	—	5.2.1
e_G	segregation and grouping error	—	5.2.1
e_P	preparation error (also known as accessory error)	—	5.2.1
e_{Q1}	short-range quality fluctuation error	—	5.2.1
e_{Q2}	long-range quality fluctuation error	—	5.2.1
e_{Q3}	periodic quality fluctuation error	—	5.2.1
e_T	total sampling error	—	5.2.1
e_W	weighting error	—	5.2.1
f_{comp}	mineralogical composition factor	t/m ³	9.2.3
f_r	size range factor	—	9.2.3
f_s	particle shape factor	—	9.2.3
H	heterogeneity index of the bulk material	—	9.2.4
H_S	heterogeneity index for the size range S of the bulk material	—	9.2.4
i	index designating the number of an increment or sub-lot depending on context	—	5.3.2
J	total number of particles in the experimental method for determining fundamental error	—	9.2.4
j	index designating the number of a particle in the experimental method for determining fundamental error	—	9.2.4
k	number of increments defining the lag of a variogram value; or in 5.4, the number of sub-lot samples	—	5.3.2
m_g	gross sample mass	kg	5.3.2
m_I	increment mass	kg	5.3.2
m_{lot}	total mass for lot	t	5.3.2
m_H	estimate of the mass of particles in the size range $d/2$ to d and used to calculate the heterogeneity index	kg	9.2.4
m_{sel}	combined dry mass of the particles selected in the method to determine the heterogeneity index	kg	9.2.4
m_{IS}	increment mass to be used for routine sampling	kg	8.2.2
m_{sub}	mass of the sub-lot	t	8.2.1

Table 1 — Symbols (continued)

Symbol	Meaning	Units	First mention
m_1	mass of container plus lid plus material test portion	kg	20.4.2
m_2	mass of drying tray	kg	20.4.2
m_3	mass of dry container plus lid plus drying tray plus material test portion	kg	20.4.2
m_4	mass of dry empty container	kg	20.4.2
n	number of increments	—	5.3.2
n_I	number of increments comprising each subsample A_i or B_i	—	5.3.3
n_{lot}	minimum number of increments for the lot		16.5
n_{sub}	number of increments taken from each sub-lot	—	16.2
q	flow rate of bulk material stream	t/h	7.2
R_i	range of paired measurements	—	5.3.3
\bar{R}	average of the ranges R_i	—	5.3.3
r	number of replicate determinations	—	5.4
s_{BS}^2	between-sample variance	—	9.2.2
s_{comp}^2	composition variance of a unit mass increment	—	5.3.2
s_D^2	distribution variance	—	5.3.2
s_F^2	fundamental error variance	—	5.3.2
s_G^2	segregation and grouping error variance	—	5.3.2
s_I^2	primary increment variance	—	5.3.3
s_{Iunc}^2	uncorrected increment variance	—	5.3.3
s_M^2	measurement (or analysis) variance	—	5.4
s_P^2	sample preparation variance	—	5.4
s_{PM}^2	sample preparation and measurement variance	—	5.3.3
s_{Q1}^2	short-range quality fluctuation variance	—	5.3.1
s_{Q2}^2	long-range quality fluctuation variance	—	5.3.1
s_{rel}^2	relative variance	—	9.2.4
s_S^2	sampling variance	—	5.3.1
s_{S1}^2	primary sampling variance	—	5.4
s_{S2}^2	secondary sampling variance	—	5.4
s_{S3}^2	tertiary sampling variance	—	5.4
s_{sub}^2	sub-lot variance	—	16.5

Table 1 — Symbols (continued)

Symbol	Meaning	Units	First mention
s_{SPM}^2	overall variance	—	5.4
s_{WSI}^2	within-sub-lot variance	—	5.3.3
t	lag value for calculating the variogram either on a time or mass basis	min (time) t (mass)	5.3.2
t_{lot}	total time for sampling the lot	min	5.3.2
t_{sub}	total time for sampling the sub-lot	min	5.3.2
u_{lot}	number of sub-lots in the lot	—	16.5
u_{sub}	number of sub-lots actually sampled in an intermittent sampling scheme	—	16.5
V_{cor}	value of corrected variogram	—	5.3.2
V_{exp}	value of experimental variogram	—	5.3.2
v_{cut}	maximum cutter speed of sampler	m/s	7.2
v_{B}	speed of conveyor belt	m/s	7.3
w_{k}	percentage by mass of key component	% by mass	9.2.3
w_{m}	air-dried moisture content of the test portion	% by mass	20.4.2
x_i	value of quality characteristic for increment i	—	5.3.2
x_m	mass-weighted average of the quality characteristic	—	9.2.4
\bar{x}	mean quality characteristic for all increments	—	5.3.3
β_{SPM}	total (or overall) precision	—	5.4
Δm	mass interval between increments	t	5.3.2
Δt	time interval between increments	min	5.3.2
λ	liberation factor	—	9.2.3
ρ	bulk density of material	t/m ³	7.4
ρ_{k}	density of particles of key component	t/m ³	9.2.3
ρ_{nk}	density of particles of non-key component	t/m ³	9.2.3
$\hat{\sigma}_{\text{F}}^2$	estimate of the fundamental error variance	—	9.2.3

Table 2 — Subscripts

Subscript	Meaning
B	conveyor belt
BS	between-sample
comp	composition
cor	corrected value
cut	cutter
del	delimitation
der	derived
D	distribution
E	extraction
e	experimental
F	fundamental
G	segregation and grouping
g	gross
<i>H</i>	heterogeneity index
<i>i</i>	index designating the number of an increment or sub-lot depending on context
I	increment
Iunc	uncorrected increment
<i>j</i>	index designating the number of a particle in the experimental method for determining fundamental error
k	key component
L	lower size limit
lot	lot
M	measurement
m	air-dried moisture content
<i>m</i>	mass-weighted average
min	minimum
nk	non-key
P	sample preparation
PM	sample preparation and measurement
Q1	short-range quality
Q2	long-range quality
Q3	periodic quality
r	size range of sieve aperture widths
rel	relative
<i>S</i>	size range

Table 2 — Subscripts (continued)

Subscript	Meaning
S	sampling
S1	primary sampling
S2	secondary sampling
S3	tertiary sampling
SPM	sampling, sample preparation and measurement (= total or overall)
s	particle shape
sel	particles selected
sub	sub-lot
T	total sampling
W	weighting
wsl	within-sub-lot
λ	liberation factor

4 Applications of bulk material sampling

This part of ISO 11648 provides guidelines for sampling, sample preparation and testing of particulate materials in bulk for a wide range of applications. Typical examples of quantities in bulk are a cargo of coal or iron ore from a single source, a partial cargo (a few cargo spaces) of concentrate or fertilizer, a barge with cement, a unit train with grain, and so on. Quantities in bulk that are defined on a time basis are less commonly specified, but examples of such quantities in bulk are masses or volumes produced during certain time intervals (e.g. shifts or 24-h periods).

Generally, a quantity of material in bulk is inspected and evaluated by collecting a set of unbiased primary increments, preparing test samples (for physical properties and/or chemical composition) without introducing a bias, and analysing test portions by applying approved test methods with properly calibrated apparatus. Adjectives are often added to describe test samples. For example, the terms “chemical analysis sample, moisture sample, size sample”, and other types of samples, are used in various ISO standard methods. The term “test portion” is used in reference to the sample mass or volume taken from test samples for testing or analysis.

Under certain conditions, the effect of a serial correlation on the sampling variance can be taken into account to refine precision estimates and to optimize statistical process control. For many materials, primary increments collected at short intervals (typically 10 min or less) are often correlated. If a sequence of measurements is correlated in space or time, variability between the serial measurements is overstated by the overall variance. On-line analysers are useful to test sets of consecutive measurements for serial correlations.

However, for most manual sampling regimes and many mechanical sampling systems, the sampling interval is too long to show a significant serial correlation between consecutive increments. Thus, the time series variance increases as a function of the sampling interval until it becomes equal to the variance of the measurements for the set of increments collected. At that spacing between primary increments, the measurements are no longer correlated in time, but have become statistically independent [2].

Duplicate test portions provide an estimate for the analytical variance, often as a function of the variable of interest. The variances between randomly distributed and ordered data sets, and the analytical variance, can be used to optimize sampling regimes for a quantity in bulk of a given intrinsic variability.

5 Principles of sampling

5.1 General

Sample inspections or evaluations of bulk particulate materials for a single lot are normally based on collecting a set of unbiased primary increments from the lot (cargo or shipment), preparing a test sample from the lot sample without introducing a systematic error, and taking a test portion from the test sample and analysing it by applying an appropriate and properly calibrated analytical method or test procedure under prescribed conditions. The precision of the variable of interest in valuable bulk materials can be estimated by dividing a shipment into four or more lots, and by selecting a pair of interpenetrating primary samples of each lot.

NOTE Statistical concepts used in this part of ISO 11648 to describe uncertainty in the measurements on samples, such as bias, precision and variance, are described in the *Guide to the expression of uncertainty in measurement*.

The objective of the operational sequence of sample collection, test sample preparation and analysis of test portions is to estimate the variable of interest in an unbiased manner, with an acceptable and affordable degree of precision. The general sampling theory, which is based on the additive property of variances, can be applied to describe how the variances of sampling, preparation and chemical analysis or physical testing cumulate to determine the total variance.

If a sampling scheme is to ensure correct selection probabilities, it is a requirement that all parts of the bulk particulate material in the lot have an equal opportunity of being selected and appearing in the lot sample for testing. Thus a quantity of material in bulk should be sampled in such a way that all possible primary increments in the set into which the quantity can be divided have a uniform finite probability to be selected. Any deviation from this basic requirement can result in an unacceptable bias. A sampling scheme with incorrect selection techniques (i.e. with non-uniform selection probabilities) cannot be relied upon to provide representative samples.

The objective of this part of ISO 11648 is to describe a common and consistent approach for collecting a set of primary increments from a lot of bulk particulate material (clauses 5 to 16) and for preparing one or more test samples without introducing a systematic error (clauses 17 to 23).

In a strict interpretation of the term, a lot of bulk material is always three dimensional. However, in many practical circumstances, two of the dimensions of the lot can be regarded as being of secondary importance. In industrial operations requiring bulk material transportation mechanisms such as conveyor belts and falling streams at transfer points, the lot can be well described by a one-dimensional model. Dynamic sampling using a stream cutter or static sampling from a stopped conveyor belt can be performed to collect representative samples from such a lot. Clauses 5 to 15 relate to dynamic and static sampling on lots regarded as being one dimensional.

In some situations, static sampling from three-dimensional lots such as stockpiles, ships' holds and wagons cannot be avoided, but it presents considerably more difficult sampling problems, and the risk of collecting unrepresentative samples is considerable. Clause 16 provides sampling procedures for sampling from three-dimensional lots.

Sampling of one-dimensional lots should preferably be carried out by stratified systematic sampling (see 5.3.2), either on a mass basis (see clause 10) or on a time basis (see clause 11). However, it needs to be shown that no systematic error (or bias) can possibly be introduced by periodic variation in quality or quantity when the proposed sampling interval is approximately equal to a multiple of the period of variation in quality or quantity.

As an example, a primary cutter may be cutting a stream of ore which is being reclaimed from a stockpile by a bucket-wheel reclaimer. At both limits of the bucket-wheel traverse across the material interface on the stockpile, the material may have different properties from that of the stockpile average (e.g. due to segregation, surface drying, oxidation, addition of dust-suppressing chemicals, or water sprays). In this case, it is quite possible that every time the primary cutter makes a cut, the cut coincides with ore being delivered from the limit of a traverse of the bucket-wheel reclaimer. Thus, a systematic error can occur.

When a systematic error is introduced at the primary sampling stage by periodic variation in quality or quantity of the particulate material, or where it is felt that, owing to the manner in which the material is handled and presented to subsequent division apparatus, a systematic error can occur in the secondary and subsequent stages of division, it is strongly recommended that stratified random sampling within fixed time or mass intervals be carried out (see clause 12).

The methods for sampling and sample preparation depend on the final choice of sampling scheme and on the steps necessary to minimize possible systematic errors arising during subsequent division steps.

5.2 Sampling errors

5.2.1 General

The processes of sampling, sample preparation and measurement are experimental procedures. As a consequence of these procedures, each process has its own element of uncertainty which results as random variations in the values measured. These random variations which average out to be a negligible value are called experimental errors. A more adverse component contributing to the uncertainty of results are systematic errors appearing as random variables which average out to a biased value away from zero. There is also the category of human errors which are variations that result from departures from the prescribed procedures and which are not random variables suited to statistical analysis.

The total sampling error e_T can be expressed as the sum of a number of independent components^[1]. However, such a simple additive combination is not appropriate for components which are correlated. The total sampling error, expressed as a sum of its components, is:

$$e_T = e_{Q1} + e_{Q2} + e_{Q3} + e_W + e_{del} + e_E + e_P \quad (1)$$

where

- e_{Q1} is the short-range quality fluctuation error associated with short-range variations in quality;
- e_{Q2} is the long-range quality fluctuation error associated with long-range variations in quality;
- e_{Q3} is the periodic quality fluctuation error associated with periodic variations in quality;
- e_W is the weighting error associated with variations in flow rate;
- e_{del} is the increment-delimitation error introduced by incorrect increment delimitation;
- e_E is the increment-extraction error introduced by incorrect increment extraction;
- e_P is the preparation error (also known as accessory error) introduced by departures (usually unintentional) from correct practices for handling of the sample.

The short-range quality fluctuation error, e_{Q1} , consists of two components, as shown by the following equation:

$$e_{Q1} = e_F + e_G \quad (2)$$

where

- e_F is the fundamental error due to variation in quality between particles;
- e_G is the segregation and grouping error.

The fundamental error results from the composition heterogeneity of the lot; that is, the heterogeneity that is inherent to the composition of each particle making up the lot. The greater the differences in the compositions of particles, the greater the composition heterogeneity, and the higher the composition variance. The fundamental error can never be completely eliminated. It is an inherent error resulting from the variation in composition of the particles of the material being sampled.

The segregation and grouping error results from the distribution heterogeneity of the sampled material^[3]. The distribution heterogeneity of a lot is the heterogeneity arising from the manner in which particles are scattered in the bulk material.

A number of the components of the total sampling error, namely e_{del} , e_{E} and e_{P} , can be made negligible by using correct sampling practices. The remainder can be minimized, or reduced to an acceptable level, by correct design of the sampling procedure.

5.2.2 Preparation error, e_{P}

In this context, the preparation error includes error associated with non-selective sample preparation operations that should not change mass, such as sample transfer, drying, crushing, grinding or mixing. It does not include errors associated with sample division or testing. Preparation errors, also known as accessory errors, include sample contamination, loss of sample material, alteration of the chemical or physical composition of the sample, operator mistakes, fraud or sabotage. These errors can be made negligible by correctly designing the plant sampling and training staff. For example, the cutters should have dust caps to prevent entry of dust when the cutter is in the parked position and moist samples should be prepared as quickly as possible to avoid loss of moisture content due to evaporation. If samples are to be extracted for use in size analysis, excessive vertical drops should be avoided, because breakage of coarse particles will alter the physical characteristics of the sample.

5.2.3 Delimitation and extraction errors, e_{del} and e_{E}

Delimitation and extraction errors arise from incorrect sample-cutter design and operation. The increment-delimitation error, e_{del} , results from an incorrect shape of the volume delimiting the increment, and this can be due to both faulty design and operation. Sampling with non-uniform selection probabilities results from an incorrect shape of the increment volume. The mean of e_{del} is often different from zero, which makes it a source of sampling bias. The delimitation error can be made negligible if all parts of the stream cross-section are diverted by the sample cutter for the same length of time.

The increment-extraction error, e_{E} , results from incorrect extraction of the increment. The extraction is said to be correct if, and only if, all particles with the centre of gravity inside the boundaries of the correctly delimited increment are extracted. The mean of e_{E} is often different from zero, which also makes it a source of sampling bias. The extraction error can be made negligible by ensuring that the increment is completely extracted from the stream without any material rebounding or being lost from the cutter.

5.2.4 Weighting error, e_{W}

The weighting error is an error component arising from the selection model underlying equation (1). In the model, the time-dependent flow rate of the particulate material stream is a weighting function applied to the time-dependent quality characteristic in the integral over time which evaluates the mean quality characteristic of the lot. The weighting error represents the error due to the amplifying effect of the flow-weighting function on the quality characteristic fluctuations. The best solution to reducing the weighting error is to stabilize the flow rate. As a general rule, the weighting error is negligible for flow-rate variations not exceeding 10 %, and acceptable for flow-rate variations not exceeding 20 %.

5.2.5 Periodic quality fluctuation error, e_{Q3}

Periodic quality fluctuation errors result from periodic variations in quality generated by certain equipment used for bulk-material handling, for example crushing and screening circuits and bucket-wheel reclaimers. The presence of periodic variations can be detected by determining the variogram (see 5.3.1). While in most cases variogram values can be fitted with a simple linear or quadratic function, if periodic behaviour (characterized by regularly spaced maxima and minima) is observed, the fitting function can include a sine wave term with a period and an amplitude to be determined as parameters of the fit^[1]. In such cases, stratified random sampling should be carried out as discussed in 5.1. The alternative is to significantly moderate the source of periodic variations in quality, which may require the redesign of plant systems.

5.3 Sampling variance

5.3.1 General

Assume that the weighting, increment-delimitation, increment-extraction and accessory errors ($e_W + e_{del} + e_E + e_P$) have been eliminated or reduced to insignificant values by careful design and sampling practice. Furthermore, assume that periodic variations in quality have been eliminated and that the flow rate has been regulated. The sampling error in equation (1) is reduced to:

$$e_T = e_{Q1} + e_{Q2} \quad (3)$$

Hence, the sampling variance s_S^2 is given by:

$$s_S^2 = s_{Q1}^2 + s_{Q2}^2 \quad (4)$$

The short-range quality fluctuation variance, s_{Q1}^2 , arises from the different internal composition of increments taken at the shortest possible interval apart. This is a local or random variance due to the particulate nature of the bulk material.

The long-range quality fluctuation variance, s_{Q2}^2 , arises from the continuous trends in quality that occur while sampling a bulk material and is usually space- and time-dependant. This component is often the combination of a number of trends generated by diverse causes.

5.3.2 Estimation of sampling variance from the variogram

In this method, the short-range and long-range quality fluctuation variances are determined from a time series analysis of a statistical experiment in which a large number (e.g. 20 to 40) of individual increments are taken in sequence from a lot, processed in accordance with the methods given in this part of ISO 11648 and the quality characteristics of each increment analysed in duplicate.

The differences between the quality characteristic values measured for successive pairs separated by k increments in the sequence are then calculated. As shown in equation (5), the squared differences are summed and divided by the number of increment pairs that can be formed having the specified separation (lag). The variance value $V_{exp}(t)$ so formed by this pooling is the serial variance for the lag of k increments. The plot of the serial variance versus lag is called a variogram. It is closely related to the auto-covariance function used in signal analysis and other engineering applications of time series analysis. A statistical experiment of this kind, for which the objective is to construct a variogram, is often called a variographic experiment. An example of a variographic experiment and the construction and plotting of a variogram are shown in annex A.

In mathematical notation, the serial variance $V_{exp}(t)$ corresponding to a lag of k increments is given by the following equation:

$$V_{exp}(t) = \frac{\sum_{i=1}^{n-k} (x_{i+k} - x_i)^2}{2(n-k)} \quad (5)$$

where

x_i is the value of the quality characteristic for increment i ($i = 1, 2, \dots, n$);

$n - k$ is the number of pairs of increments at integer lag k apart;

t is equal to $k\Delta t$, where Δt is the sampling interval in units of time (expressed in minutes) or to $k\Delta m$ where Δm is the sampling interval in units of mass (expressed in tonnes), depending on whether time-basis or mass-basis sampling is used.

The term $(n - k)$ in the denominator of equation (5) reflects the degrees of freedom for the variance term at the specified interval k , while the factor of 2 in the denominator ensures that, as $t \rightarrow 0$, $V_{\text{exp}}(t)$ tends to the conventional variance of measurements, taken at the same position.

The resultant variogram, $V_{\text{exp}}(t)$, is called the “experimental” variogram, and includes the variance of sample preparation and measurement as well as the sampling variance. If the extracted increments are prepared and analysed in duplicate, the sample preparation and analysis variance can be determined in accordance with the procedures described in ISO 3084. Subtraction of the sum of the sample preparation and analysis variances ($s_{\text{P}}^2 + s_{\text{M}}^2$) from the calculated value of $V_{\text{exp}}(t)$ at each lag gives the “corrected” variogram, $V_{\text{cor}}(t)$, which provides information on the sampling variance only. However, caution should be observed when subtracting the sample preparation and analysis variance from the serial variance values of the experimental variogram. The difference between the serial variance and the sample preparation and analysis variance is only a valid estimate for the sampling variance if the F -ratio between these variances is statistically significant.

Variograms that occur in practice can usually be approximated in the range $0 \leq t \leq 4\Delta t$ by a straight line. The two coefficients of the straight line (intercept A_{exp} and slope B) shall be determined by a linear least squares fit to the experimental variogram values of the first four lags.

NOTE The variographic method for determining the sampling variance is applicable to the sampling of a stream of bulk material from one production source, but when a lot may consist of sub-lots from different sources, difficulties are encountered.

Thus, it can be assumed that, in the range $0 \leq t \leq 4\Delta t$, an acceptable approximation to the corrected variogram is the linear function:

$$V_{\text{cor}}(t) = A_{\text{cor}} + B \cdot t = (A_{\text{exp}} - s_{\text{P}}^2 - s_{\text{M}}^2) + B \cdot t \quad (6)$$

where

A_{cor} is the random component of variance of the corrected variogram;

A_{exp} is the experimental intercept of the experimental variogram;

B is the gradient (or slope) of the variogram. B is expressed in units of inverse mass (expressed in tonnes⁻¹) for mass-basis sampling, or inverse time (expressed in min⁻¹) for time-basis sampling;

s_{P}^2 is the sample preparation variance;

s_{M}^2 is the measurement (or analysis) variance.

It should be noted that the linear approximation to the variogram based on a four-point fit is subjective to the extent that taking more or less points will result in a different linear fit. This includes the procedure where a line is passed through the first two points. The estimates of the parameters A_{cor} and B and the variances derived from these parameters are also subjective to the same extent.

The sampling variances, s_{S}^2 , for stratified systematic sampling and stratified random sampling have been shown to be related to the coefficients A_{cor} and B of the linear approximation. Equations (7) and (8) given below for sampling variances are derived by establishing a mathematical relationship between the variogram values and the variance of the estimation error between the sample mean and the population mean[1].

a) Stratified systematic sampling:

$$s_{\text{S}}^2 = \frac{A_{\text{cor}}}{n} + \frac{B \cdot m_{\text{lot}}}{6n^2} \quad (7)$$

where

n is the number of increments;

m_{lot} is the total mass, expressed in tonnes, of the lot.

Strictly, this equation is only precise for centralized systematic sampling, where the increment is taken from the centre of each stratum. However, in practice, it is a close approximation to the sampling variance for non-central systematic sampling.

b) Stratified random sampling:

$$s_{\text{S}}^2 = \frac{A_{\text{cor}}}{n} + \frac{B \cdot m_{\text{lot}}}{3n^2} \quad (8)$$

NOTE Equations (7) and (8) apply to mass-basis sampling. For time-basis sampling, m_{lot} is replaced by t_{lot} , the total time, expressed in minutes, for sampling the lot.

Thus, where there are no periodic variations in quality, systematic sampling is more precise than stratified random sampling.

In Equations (7) and (8), the first and second terms correspond to the short-range and long-range quality fluctuation variances respectively. Thus, for stratified systematic sampling:

$$s_{\text{Q1}}^2 = \frac{A_{\text{cor}}}{n} ; \text{ and} \quad (9)$$

$$s_{\text{Q2}}^2 = \frac{B \cdot m_{\text{lot}}}{6n^2} \quad (10)$$

The variogram intercept A_{cor} is made up of two components [1]:

- the segregation and grouping error variance s_{G}^2 ;
- the fundamental error variance s_{F}^2 for the particular increment mass used for the variographic experiment.

The fundamental error variance for the increment mass results from the particle-to-particle variation in quality of the material making up the increment; it can be determined as described in clause 9. The fundamental error variance for the increment mass is proportional to the cube of the nominal top size and inversely proportional to the increment mass. Thus, the variogram intercept A_{cor} can be expressed as follows:

$$A_{\text{cor}} = s_{\text{G}}^2 + \frac{A_{\text{F}} \cdot d^3}{m_{\text{I}}} \quad (11)$$

where

A_{F} is a constant with the same units as density (expressed in kilograms per cubic millimetre, or kilograms per cubic metre $\times 10^{-9}$);

d is the nominal top size, expressed in millimetres, of the particles;

m_{I} is the increment mass, expressed in kilograms.

If the results of a variographic experiment are to be applied to sampling with a different increment mass, it is necessary to determine A_F (see clause 9).

For stratified systematic sampling, combining the above equations gives:

$$s_S^2 = \frac{A_F \cdot d^3}{m_g} + \frac{s_G^2}{n} + \frac{B \cdot m_{lot}}{6n^2} \quad (12)$$

where

$\frac{A_F \cdot d^3}{m_g}$ is the fundamental error variance for the gross sample mass;

m_g is the gross sample mass, expressed in kilograms, and is equal to $n \cdot m_I$.

Hence, the fundamental error component of the sampling variance for the gross sample mass is determined by the nominal top size of the bulk material and the gross sample mass.

NOTE While the methods of this part of ISO 11648 are likely to be satisfactory for many bulk materials other than ores, mineral concentrates, coal, and industrial chemicals in particulate form, caution should be observed when applying relationships such as that between the fundamental error variance, particle size and gross sample mass to materials with particle shapes and densities markedly different from minerals, for example, to wood chips or bulk tea. In these cases, fully experimental methods should be used and supported by a program of test work (see 9.2.2).

EXAMPLE An example showing the use of the variogram intercept A_{COR} and the variogram slope B to calculate the sampling variance is given in A.4 of annex A.

The quantities:

$$A_F \cdot d^3 \quad \text{and} \quad s_G^2 + \frac{B \cdot m_{lot}}{6n}$$

are referred to by some authors as the “composition variance of a unit mass increment” and the “distribution variance” respectively.

Then:

$$s_S^2 = \frac{s_{comp}^2}{m_g} + \frac{s_D^2}{n} \quad (13)$$

where

s_{comp}^2 is the composition variance of a unit mass increment;

s_D^2 is the distribution variance.

Note that for a “flat” variogram, where $B = 0$, the distribution variance, s_D^2 , is equivalent to the grouping error variance, s_G^2 .

5.3.3 Alternative methods of estimating sampling variance

The variographic method suffers to some extent from the subjectivity inherent in approximating the variogram at small lag values with a linear function. Ambiguous variograms are sometimes encountered which give wide variations for slope and intercept depending on the number of variogram values included in the least squares fit. However, the variographic method in which sampling variance is estimated from the experimental variogram is more rigorous than others available.

There are two simpler methods, each having the advantages of being easier and less costly to apply than the variographic method. These are the increment variance method and the within-strata variance method. The increment variance method provides a better margin of safety.

However, unlike the variographic method, each of these alternative methods has the disadvantage of not being able to determine the separate contributions of the short-range and long-range fluctuation error variances, i.e.:

$$s_{Q1}^2 \text{ and } s_{Q2}^2$$

Consequently, if the sampling variance needs to be reduced, these methods do not show whether the mass of individual increments or the number of increments needs to be increased. In contrast, the variogram method immediately provides this information.

The alternative methods are as follows.

a) Increment variance

The uncorrected increment variance, s_{Iunc}^2 , biased by the preparation and measurement variance is defined as the variance of the quality characteristics of all increments taken from the lot, i.e.:

$$s_{Iunc}^2 = \frac{1}{n-1} \sum_{i=1}^n (x_i - \bar{x})^2 \quad (14)$$

where

n is the number of increments;

x_i is the value of the quality characteristic for increment i ;

\bar{x} is the average of the quality characteristic measured on all increments.

The sample preparation and measurement variance, s_{PM}^2 , which should be determined by duplicate preparation and testing on each increment as in the variographic method, is subtracted from the uncorrected increment variance to obtain the primary increment variance, s_I^2 .

The estimated sampling variance is then given by:

$$s_S^2 = \frac{s_{Iunc}^2 - s_{PM}^2}{n} = \frac{s_I^2}{n} \quad (15)$$

This method overestimates the sampling variance, because it neglects trends and assumes that there is no correlation between adjacent increments.

b) Within sub-lot variance

The within sub-lot variance method involves determining the variance of the desired quality characteristic within sub-lot (s_{WSL}^2) by duplicate sampling in accordance with ISO 3084. In ISO 3084, this variance is called the variance within-strata as the lot is considered to be divided into n approximately equal sub-lots in a partitioning based on mass, time or space (i.e. in strata, where each stratum defines a sub-lot).

The lot is divided into n sub-lots. The procedure for constituting duplicate sub-lot samples for each sub-lot is in accordance with ISO 3084. Test samples are prepared from each sub-lot sample and the quality characteristic measured.

The range, R_i , of paired measurements is given by the equation:

$$R_i = |a_i - b_i| \quad (16)$$

where

a_i is the measurement of quality characteristic of the test sample prepared from sub-lot sample A_i ;

b_i is the measurement of quality characteristic of the test sample prepared from sub-lot sample B_i which pairs with sub-lot sample A_i ;

i is the subscript which designates each sub-lot.

The average of the ranges R_i is given by the equation:

$$\bar{R} = \frac{\sum R_i}{n} \quad (17)$$

where n is the number of R_i , i.e. the number of pairs of sub-lot samples.

For example, 100 increments may be required to be extracted from the lot, and 10 pairs (i.e. $n = 10$) of sub-lot samples, each comprised of five increments, are constituted in accordance with the methods of ISO 3084. Test samples are prepared from each of these 20 sub-lot samples and the quality characteristic measured for each test sample.

The estimated within sub-lot variance, s_{WSL}^2 , in one investigation is given by the equation:

$$s_{\text{WSL}}^2 = \frac{\pi}{4} n_1 \bar{R}^2 \quad (18)$$

where

n_1 is the number of increments comprising each subsample A_i or B_i ;

$\pi/4$ is the factor to estimate variance from the range for paired data.

The estimated sampling variance in this case is given by:

$$s_{\text{S}}^2 = \frac{s_{\text{WSL}}^2 - s_{\text{PM}}^2}{n} \quad (19)$$

However, the value of s_{WSL}^2 obtained depends on the size of the strata used for collecting the data, i.e. the mass or time interval between increments. Consequently, the within sub-lot variance method should be used only where the proposed sampling interval is not greatly different from that used to determine s_{WSL}^2 .

5.4 Total variance and precision

The total (or overall) variance is denoted by s_{SPM}^2 . It comprises three components, namely the variance of sampling, the variance of sample preparation and the variance of measurement, as given in equation (20).

$$s_{\text{SPM}}^2 = s_{\text{S}}^2 + s_{\text{P}}^2 + s_{\text{M}}^2 \quad (20)$$

where

s_{S}^2 is the sampling variance;

s_{P}^2 is the sample preparation variance;

s_{M}^2 is the measurement variance.

The methods for determining estimates of s_{S}^2 may be found in 5.3.2 and 5.3.3 of this part of ISO 11648.

NOTE The distinction between “sampling” and “sample preparation” is not always clear. For the purposes of this part of ISO 11648, “sampling” stages denote those stages of sampling and sample division that take place within the sampling plant where primary increments are extracted and where possibly size reduction, secondary and tertiary division of primary increments are carried out. Whereas, “sample preparation” stages denote those stages that take place away from the sampling plant, typically in the plant laboratory. The principles of sampling given in 5.3 apply to sample preparation stages as well as to the sampling stages.

The total (or overall) precision, β_{SPM} , is a measure of the combined precision of sampling, sample preparation, and measurement. For a symmetrical two-sided confidence interval of 95 % and where the number of independent comparisons (degrees of freedom) that can be made among the set of measurements is large.

$$\beta_{\text{SPM}} = 1,96 s_{\text{SPM}}$$

In practice, the approximation:

$$\beta_{\text{SPM}} = 2s_{\text{SPM}} = 2\sqrt{s_{\text{S}}^2 + s_{\text{P}}^2 + s_{\text{M}}^2} \quad (21)$$

is often used in bulk materials sampling standards.

Where secondary and tertiary division of primary increments is carried out, the sampling variance can be split into a number of parts as follows:

$$s_{\text{S}}^2 = s_{\text{S}1}^2 + s_{\text{S}2}^2 + s_{\text{S}3}^2 \quad (22)$$

where

$s_{\text{S}1}^2$ is the primary sampling variance;

$s_{\text{S}2}^2$ is the secondary sampling variance;

$s_{\text{S}3}^2$ is the tertiary sampling variance.

Again, the principles of 5.2 apply to each stage. Separate experiments are required to establish the magnitude of each component. Such experiments are useful for identifying the major sources of variance. Splitting the sample variance into its components can also assist in the design of sampling equipment. On the other hand, if all increments are processed in the same manner and only the total sampling variance is required, there is no need to separate the components.

Where a very precise result is required and the sampling variance has been minimized, consideration has to be given to increasing the number of sample preparations and measurements, to reduce these components of the overall variance.

This is achieved by:

- carrying out multiple determinations on the gross sample;
- analysing individual increments (see Figure 1); or
- dividing the lot into a number of sub-lots and analysing a sample from each sub-lot (see Figure 2).

The overall variance in each case is then given by one of the following equations:

- a) where a single gross sample is constituted from a lot and r replicate determinations are carried out on the gross sample:

$$s_{\text{SPM}}^2 = s_{\text{S}}^2 + s_{\text{P}}^2 + \frac{s_{\text{M}}^2}{r} \quad (23)$$

- b) where k sub-lot samples are prepared, each constituted from an equal number of increments, and r replicate determinations are carried out on each sub-lot sample:

$$s_{\text{SPM}}^2 = s_{\text{S}}^2 + \frac{s_{\text{P}}^2 + \frac{s_{\text{M}}^2}{r}}{k} \quad (24)$$

- c) where all n increments are prepared and a single determination is carried out on each increment:

$$s_{\text{SPM}}^2 = s_{\text{S}}^2 + \frac{s_{\text{P}}^2}{n} + \frac{s_{\text{M}}^2}{n} \quad (25)$$

In each case, the sampling variance is determined from the equations given in 5.3.

NOTE The determination of moisture requires special consideration due to the fact that it is extremely difficult, if not impossible, to retain the integrity of the sample over extended periods of sample collection. In such cases, a bias may occur which can be overcome only by collecting moisture samples at more frequent intervals than may be dictated by a simple calculation of the number of primary increments and sub-lot samples for a given precision. It is therefore recommended that moisture tests be carried out on a number of sub-lot samples, and that the average of the test results be calculated, the average weighted according to the masses of the sub-lots in the case of time-basis sampling, or according to the number of increments in each sub-lot sample in the case of mass-basis sampling. This will reduce any bias in the test result caused by moisture loss (or gain) due to climatic conditions. It will also result in better precision. In exceptional circumstances, where the moisture loss is very rapid, secondary and tertiary division is not permissible, unless the sampling system is totally enclosed and handling is minimized.

6 Establishing a sampling scheme

Most sampling operations are routine and conform to the definition of regular sampling defined in ISO 11648-1. Regular sampling is sampling carried out by the stipulated procedures in the relevant International Standard in order to determine the average quality of the lot. In establishing a sampling scheme for regular sampling so that a specified precision on a quality characteristic for a lot can be obtained, it is necessary to carry out the following sequence of steps. The sequence includes experimental sampling procedures, such as step g) below, which are not routine and are carried out only infrequently, as, for example, when there is a significant alteration in conditions such as a change in the source of the particulate material or in the sampling equipment.

ISO 11648-2:2001(E)

- a) Define the purpose for which the samples are to be taken. Sampling for the quality verification requirements of commercial transactions is the central purpose within the scope of this part of ISO 11648 and other sampling standards. However, the procedures described in this part of ISO 11648 are applicable to sampling for the purpose of monitoring plant performance and for process control as well.
- b) Identify the quality characteristics to be measured. Specify the total precision (combined precision of sampling, sample preparation and measurement) required for each quality characteristic. It may be found that the required precision gives impractical numbers of primary increments and sub-lots. In such cases, it may be necessary to accept poorer precision.
- c) Define the lot, including its mass or duration.
- d) Define the sub-lots, including their number and their masses or durations.
- e) Ascertain the nominal top size and particle density of the bulk material for use in determining the gross sample mass in step i). The nominal top size also determines the minimum cutter aperture width required to avoid bias where a mechanical sampler is used, or the minimum size of the ladle required to avoid bias where manual sampling is used.
- f) Check that the procedures and equipment for taking increments avoid significant bias (see clause 7).
- g) Determine the variability of the quality characteristics under consideration, using the variogram method or one of the alternatives (see clause 5).
- h) Determine the number of primary increments to be taken from the lot or the sub-lots to be tested (see clause 8).
- i) Determine the minimum gross sample mass (see clause 9).
- j) Determine the sampling intervals, in tonnes for mass-basis systematic sampling (see clause 10) and stratified random sampling within fixed mass intervals (see clause 12), or in minutes for time-basis systematic sampling (see clause 11) and stratified random sampling within fixed time intervals (see clause 12).
- k) Take primary increments at the intervals determined in step j) during the whole period of handling the lot.

In experimental sampling, each increment may be analysed separately (see Figure 1) to assess the variability of the quality characteristic in the lot by monitoring the variogram. Or the primary increments may be taken from a sub-lot (see 10.5 or 11.5) to constitute a sub-lot sample which may also be analysed to assess lot variability (see Figure 2). These are only two of a variety of other experimental sampling schemes possible (see, for example, the fully-nested and staggered-nested experiments described in part 1 of this International Standard, i.e. ISO 11648-1).

In regular sampling, a typical sampling scheme is to combine sub-lot samples so as to constitute a gross sample for analysis (an example is given in Figure 3). Periodically, checks should be made on the precision achieved by the sampling scheme by means of replicate sampling, i.e. by replication of the gross sample. For example, if duplicate sampling is used, each alternate primary increment is diverted so that gross samples A and B are formed (see Figure 4) from which two test samples are prepared and tested.

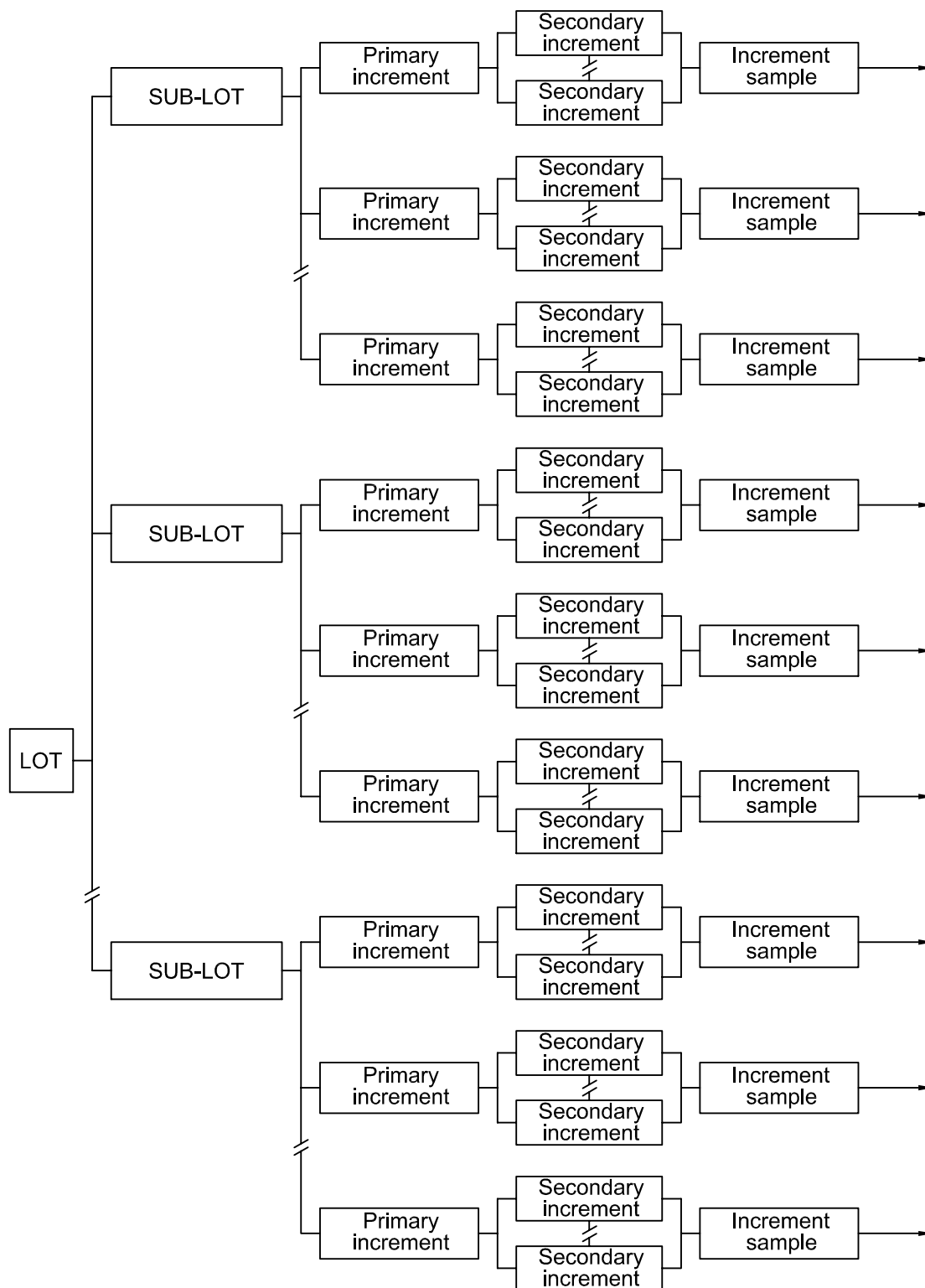

NOTE Each increment sample is prepared and analysed separately.

Figure 1 — Example of a scheme for experimental sampling with each increment analysed separately

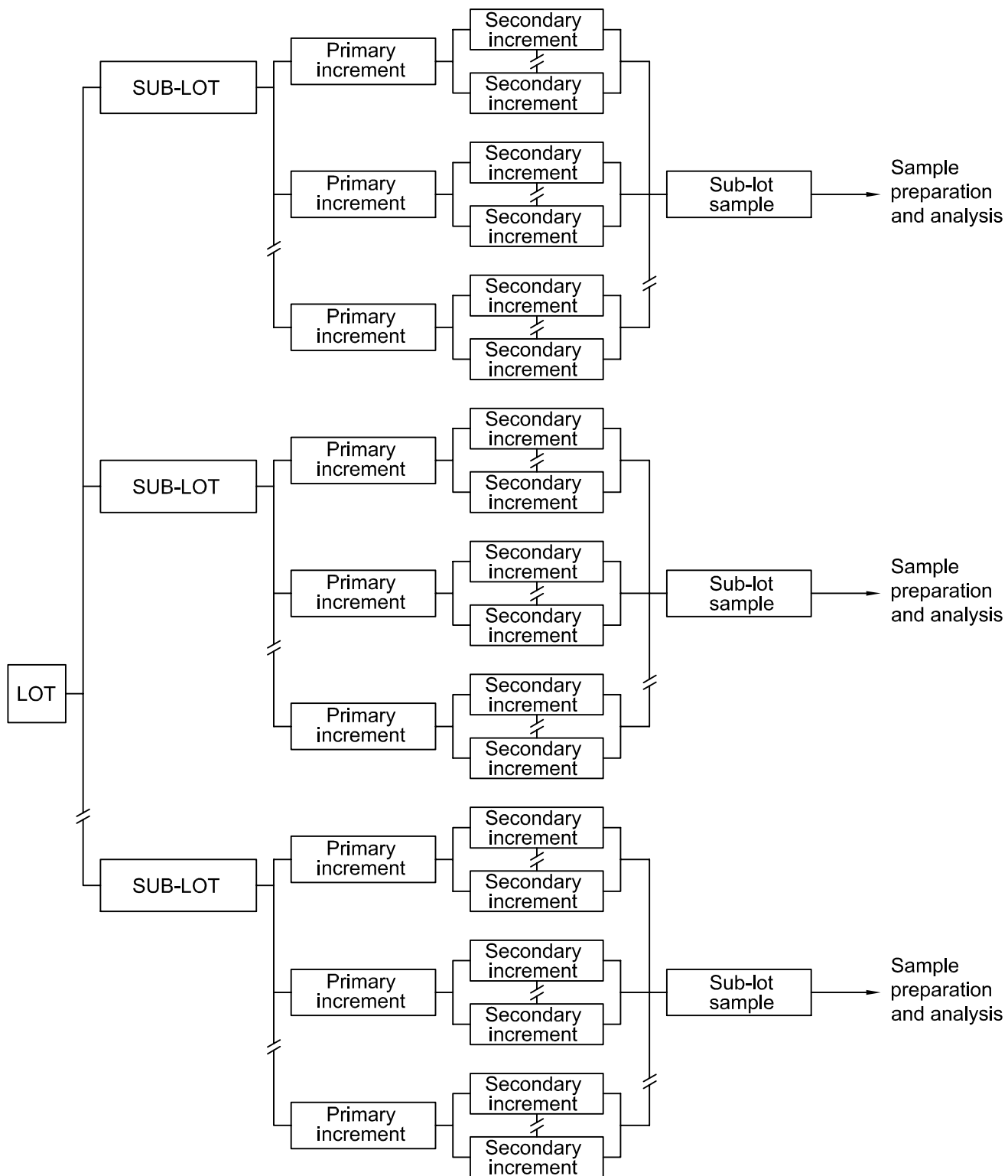

Figure 2 — Example of a scheme for experimental sampling with each sub-lot sample analysed separately

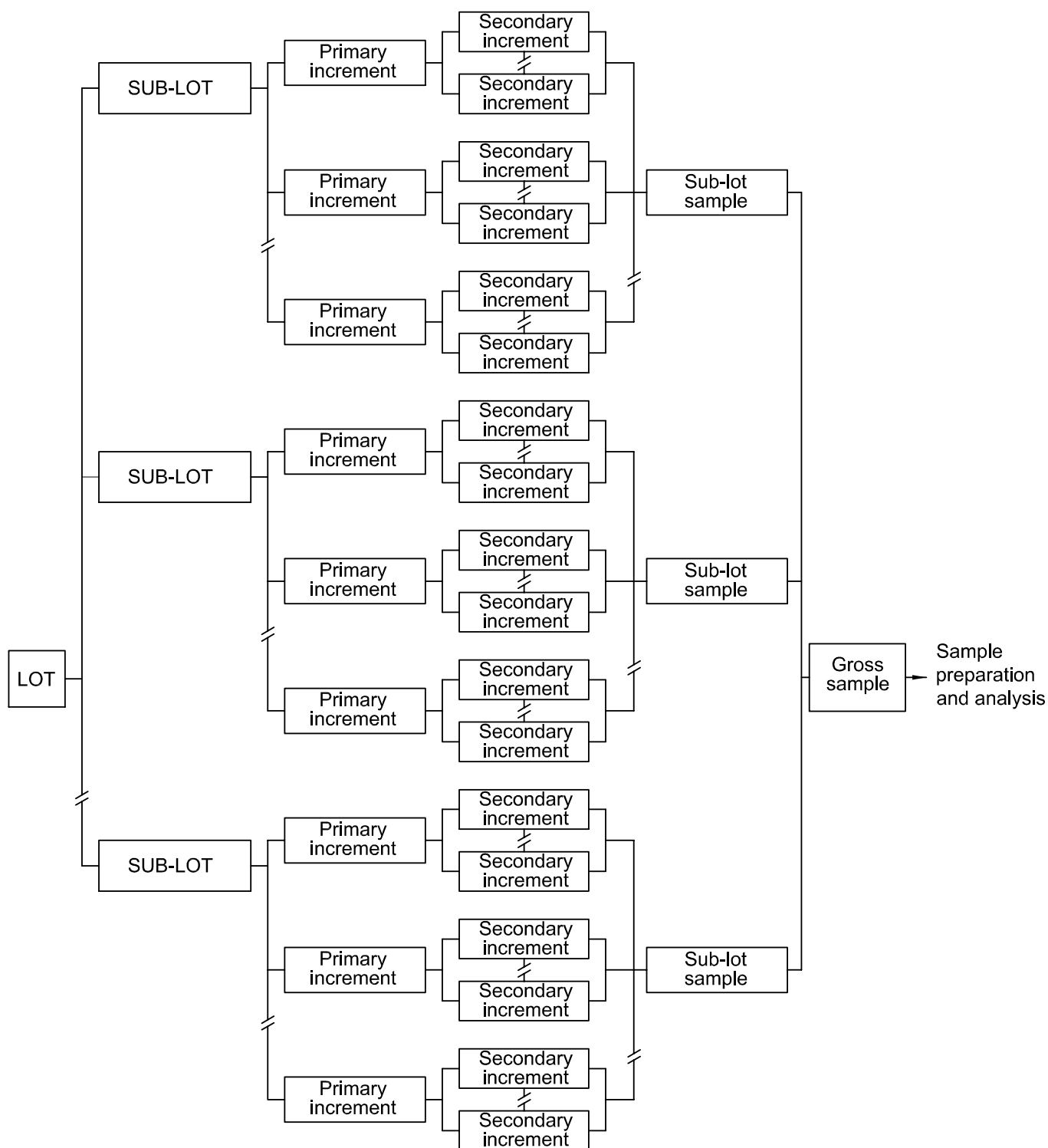

Figure 3 — Example of a scheme for routine sampling

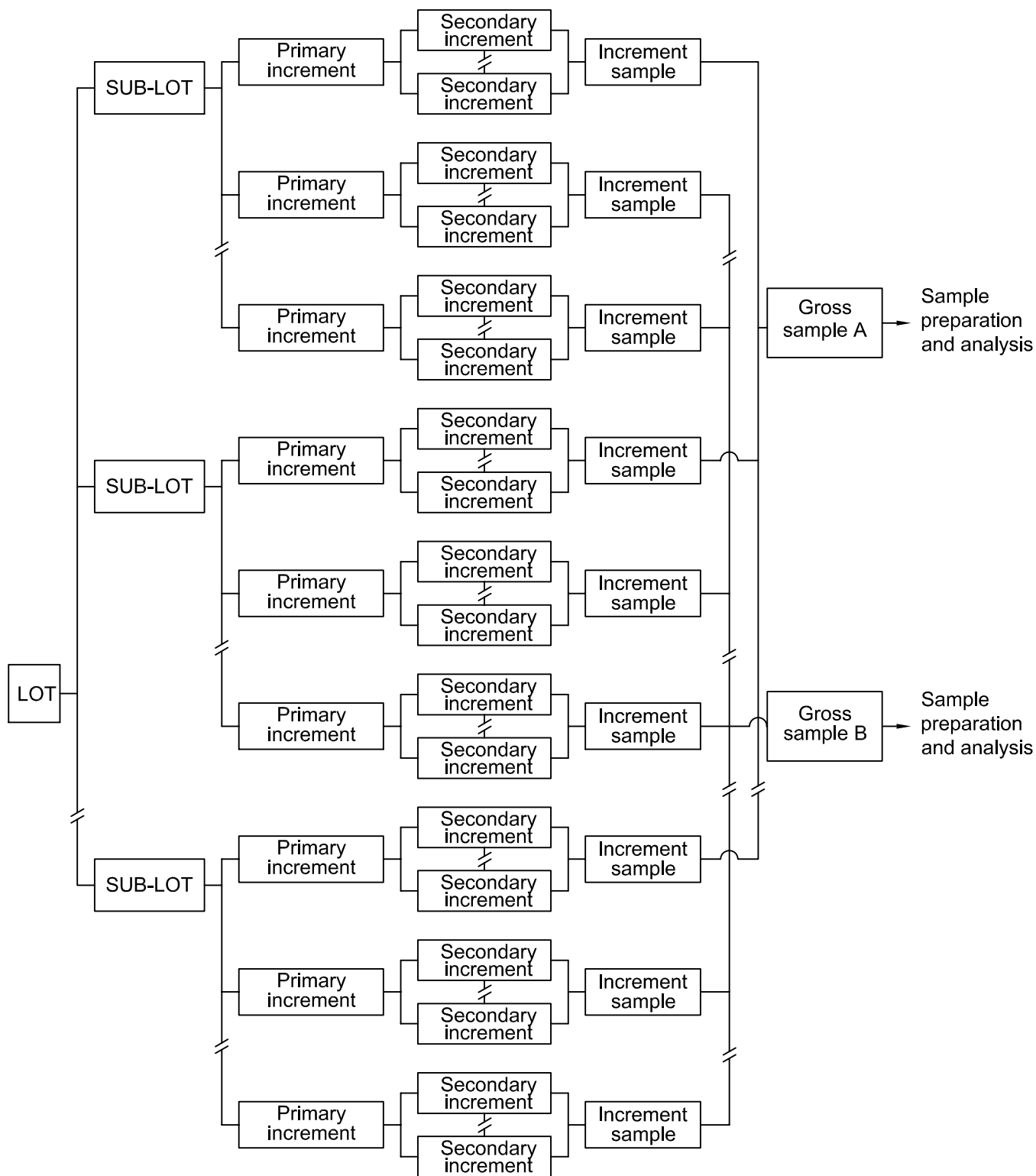

Figure 4 — Example of a scheme for duplicate sampling

Sub-lot samples are usually prepared and analysed separately to improve the overall precision. Other reasons for separate preparation and analysis of sub-lot samples are:

- for convenience of materials handling;
- to provide progressive information on the quality of the lot;
- to provide, after division, reference or reserve samples; or
- to reduce, in the moisture test result of a large lot, any bias caused by moisture loss (or gain) due to climatic conditions.

Large primary increments may be divided at step i) before constituting a lot sample or sub-lot sample. However, this will introduce an additional source of sampling error, which can be determined as discussed in 5.2. If all of the primary increment or divided primary increment is crushed to enable further division, it is necessary to recalculate the minimum sample mass for the lot, using the nominal top size of the crushed bulk material in the equation (see clause 9).

The initial design of a sampling scheme for a new plant or a bulk material with unfamiliar characteristics (e.g. a new material type) should, wherever possible, be based on experience with similar handling plants and material type. Alternatively, an arbitrary number of increments, for example 100, can be taken and used to determine the variability of the bulk material, but the precision of sampling cannot be determined beforehand.

Establishing a satisfactory scheme for sampling from stationary situations such as from stockpiles, stopped conveyor belts, wagons and ship's holds, presents particular difficulties if bias is to be avoided. Sampling in these situations should be carried out by systematic stratified sampling, but only when it can be shown that no systematic error can be introduced due to any periodic variation in quality or quantity which may coincide with, or approximate to, any multiple of the proposed sampling intervals. In the event that it is possible that systematic errors can be introduced due to periodic variations in quality or quantity, stratified random sampling should be used.

7 Mass of increment and minimization of bias

7.1 Minimization of bias

Minimization of bias in sampling and sample preparation is vitally important. Unlike precision, which can be improved by collecting more primary increments, by preparing more test samples, or by assaying more test portions, a bias cannot be reduced by replication. Consequently, sources of bias should be minimized or eliminated at the outset by correct design of the sampling and sample preparation system. The minimization or elimination of possible bias should be regarded as more important than the improvement of precision.

Sources of bias that can be eliminated include sample spillage, sample contamination, and incorrect extraction of increments, while sources that can be minimized but not eliminated are, for example, net moisture flows between the sample and the outside air as well as loss of dust and particle degradation in sample preparation prior to size distribution determination.

The guiding principle to be followed is that it is essential that increments be extracted from the lot in such a manner that all parts of the bulk material have an equal opportunity of being selected and becoming part of the test sample which is used for chemical or physical testing, irrespective of the size, mass or density of individual particles. In practice, this means that a complete cross-section of the bulk material is to be taken when sampling from a moving stream, and a complete column of bulk material is to be extracted when sampling from a stationary lot.

The requirement of equal selection probabilities should be borne in mind when specifying each component of the sampling system design. Practical rules follow from the application of the principle to specific design issues, but these are too numerous to fully list here. However, several examples of design rules which follow from the principle are that:

- cutter blades should be sufficiently long to intercept bouncing particles;
- the cutter lips on straight path cutters should be parallel, and the cutter lips of Vezin²⁾ cutters should be radial from the axis of rotation;
- cutter lips on straight path cutters should remain parallel, even after significant wear;
- cutters should accelerate from rest while still clear of the stream, traverse the stream at constant velocity, and then decelerate to a stop only after emerging from the stream.

As explained in 7.2, 7.3 and 7.4, the determination of minimum aperture widths and dimensions of sampling equipment and maximum cutter speeds required to obtain an unbiased sample, leads to the derivation of an increment mass consistent with these limiting specifications.

However, in some circumstances, use of this derived increment mass and the equations in 8.2 can require a large number of increments to obtain the desired sampling variance. In such cases, the increment mass should be increased above the derived value.

Cutters should be designed for the maximum particle size and the maximum flow rate. From these values, the maximum increment mass and volume can be calculated for design checks. In particular, the choice between manual or mechanical sampling should be based on the maximum possible increment mass.

Once a cutter is installed, perform regular checks on the average increment mass. Compare this mass with the mass predicted using either values of the cutter aperture width, the cutter speed and the bulk material mass flow rate in the case of falling-stream cutters (7.2) or those of the cutter aperture width, the belt speed and the mass flow rate in the case of cross-belt cutters (7.3). If the average increment mass is too small compared with the predicted increment mass for the observed flow rate, it is likely that large particles are being under-sampled.

7.2 Mass of increment from falling-stream samplers designed to avoid bias

At any sampling stage, the mass of the increment, taken by a cutter-type sampler from the bulk material at the discharge end of a moving stream, is determined by the minimum cutting aperture width and the maximum cutter speed required to obtain an unbiased sample. It may be calculated using the following equation:

$$m_I = \frac{q \cdot b_{\min}}{3,6 v_{\text{cut}}} \quad (26)$$

where

- m_I is the mass, in kilograms, of the increment;
- q is the flow rate, expressed in tonnes per hour, of bulk material stream;
- b_{\min} is the minimum cutting aperture width, expressed in metres, of the sampler (see 13.3.2);

²⁾ Vezin cutter (also called Vezin sampler and at the laboratory scale, Vezin sample divider) is a circular path rotary-chute cutter consisting essentially of open chute or chutes rotating at constant angular velocity around a vertical axis [see Figure B.1 g)]. The cutter opening is formed by the sides of the pivoting chute and in high-wear operating conditions, replaceable cutter lips are attached to the chute edges. The particulate material flow is parallel to the axis of rotation of the cutter. For unbiased operation, the cutter edges should be radial, i.e. the cutter edges should lie on a line passing through the centre of rotation. The Vezin cutter is named after the 19th century sampling pioneer, H. A. Vezin.

v_{cut} is the maximum cutter speed, expressed in metres per second, of the sampler (see 13.3.4);

3,6 is a conversion factor that converts flow rate units of tonnes per hour to kilograms per second.

NOTE Equation (26) is valid for all values of the cutter aperture width and the cutter speed, but aperture widths set below the minimum aperture width and speeds higher than the maximum one can be expected to cause bias.

7.3 Mass of increment for cross-belt samplers designed to avoid bias

Determine the mass of the increment taken by a cross-belt sampler from a moving stream using the minimum cutting aperture width required to obtain an unbiased sample. It may be calculated using the following equation:

$$m_I = \frac{q \cdot b_{\text{min}}}{3,6 v_B} \quad (27)$$

where

m_I is the mass, expressed in kilograms, of the increment;

q is the flow rate, expressed in tonnes per hour, of bulk material stream;

b_{min} is the minimum cutting aperture width, expressed in metres, of the sampler (see 13.3.3);

v_B is the speed, expressed in metres per second, of the conveyor belt;

3,6 is a conversion factor that converts flow rate units of tonnes per hour to kilograms per second.

NOTE Equation (27) is valid for all values of the cutter aperture width and the cutter speed, but aperture widths set below the minimum aperture width and speeds higher than the maximum one can be expected to cause bias.

7.4 Mass of increment for manual sampling implement designed to avoid bias

Determine the mass of the increment for manual sampling of bulk material using the minimum sampling volume of the manual sampling implement (for example, a scoop) required to obtain an unbiased sample. Assuming this volume to be a cube of minimum side dimension equal to $3d$, then the minimum sampling volume is equal to $3d \times 3d \times 3d$. Calculate the mass of increment using the following equation:

$$m_I = 27\rho \cdot d^3 \cdot 10^{-6} \quad (28)$$

where

m_I is the mass, expressed in kilograms, of the increment;

ρ is the bulk density of the material, expressed in tonnes per cubic metre;

d is the nominal top size, expressed in millimetres, of the particles of the material.

7.5 Increment mass for moisture sample

To avoid bias, there is a practical minimum increment mass that should always be exceeded to minimize the effect of handling on the characteristics of the bulk material in the increment as it passes through the sampling system. This is particularly important for the moisture sample where moisture loss (or gain) due to climatic conditions is to be minimized. Specify the minimum mass for each bulk material type and over a range of ambient conditions such as temperature and humidity. Other important factors are the specific surface area, how long increment surfaces are exposed, the capacity of the sample preparation system and whether on-line crushing is used. The correct determination of a minimum mass for moisture sample may only be possible by conducting bias experiments.

8 Number of increments

8.1 General

The number of increments to be taken from a lot or sub-lot to attain the required sampling precision is dependent on the variability of the quality characteristic to be determined. The variability is quantified by the variogram of the quality characteristic, as described in clause 5. Where determination of the variogram is impractical, the increment variance or the within sub-lot variance methods may be used, but with the limitations noted in 5.3.

8.2 Calculation of number of increments

8.2.1 General

The number of increments required to achieve a given sampling variance for a particular lot or sub-lot depends on:

- the variability of the quality characteristic of interest;
- the mass, m_{lot} (or duration t_{lot}) of the lot, or the mass, m_{sub} (or duration t_{sub}) of the sub-lot, and
- the mass, m_I , of each increment.

The variability may be determined by any of the methods specified in 5.3 provided that the increment mass used in the determination is the same as that used for sampling. Where the increment mass is to be changed, only the variogram method can be used unless test work is conducted to reassess the variability.

The number of increments required may be calculated by one of the methods given in 8.2.2 to 8.2.3. These methods are given explicitly for mass-basis sampling from the lot and, therefore, the equations include the mass m_{lot} . The methods also apply to time-basis sampling from the lot where t_{lot} replaces m_{lot} in the equations, or in mass- or time-basis sampling from the sub-lot, which requires m_{sub} or t_{sub} in the equations.

8.2.2 Variogram method

Calculate the number of increments, n , necessary to achieve the required sampling variance for either stratified systematic sampling or for stratified sampling using a derived variogram intercept and the variogram slope obtained from a least squares fit to the experimental variogram. Determine the number of increments, n , for any of the sampling methods by solving for the positive root of the quadratic equations in n , of equations (7) and (8), as follows:

- a) for stratified systematic sampling:

$$n = \frac{A_{der} + \sqrt{A_{der}^2 + \frac{2}{3} B \cdot m_{lot} \cdot s_S^2}}{2 s_S^2} \quad (29)$$

- b) for stratified random sampling:

$$n = \frac{A_{der} + \sqrt{A_{der}^2 + \frac{4}{3} B \cdot m_{lot} \cdot s_S^2}}{2 s_S^2} \quad (30)$$

where

$$A_{der} = \frac{AF \cdot d^3}{m_{IS}} + s_G^2 \quad (31)$$

- A_{der} is the derived variogram intercept for the increment mass m_{IS} to be used for sampling, and equals the sum of the fundamental error variance for the increment mass m_{IS} and the grouping and segregation variance;
- B is the variogram slope, in tonnes⁻¹;
- m_{lot} is the mass, in tonnes, of the lot;
- s_{S1}^2 is the required sampling variance.

The increment mass for sampling m_{IS} may be different from the increment mass m_{I} used in the variographic experiment to determine variability; in which case the derived variogram intercept A_{der} will be different from the experimentally determined intercept A_{cor} .

Based on a large number of variographic experiments, it has been demonstrated^[1], that the grouping and segregation variance s_{G}^2 is either smaller or about the same magnitude as the fundamental variance. Consequently, it is conservative to assume that equations (11) and (31) can be simplified to the approximations:

$$A_{\text{cor}} = \frac{2 A_{\text{F}} \cdot d^3}{m_{\text{I}}} \quad (32)$$

$$A_{\text{der}} = \frac{2 A_{\text{F}} \cdot d^3}{m_{\text{IS}}} \quad (33)$$

giving:

$$A_{\text{der}} = \frac{A_{\text{cor}} \cdot m_{\text{I}}}{m_{\text{IS}}} \quad (34)$$

NOTE If B is small compared with $\frac{A_{\text{der}}^2}{m_{\text{lot}} \cdot s_{\text{S}}^2}$, both equations (29) and (30) are well approximated by:

$$n = \frac{A_{\text{der}}}{s_{\text{S}}^2}$$

8.2.3 Increment variance and within sub-lot variance methods

Neither of these methods allows the sampling variance to be broken into its individual components; hence the estimated variance has to be treated as a single quantity.

a) Increment variance method

After rearranging equation (15), calculate the number of increments according to equation (35).

$$n = \frac{s_{\text{Iunc}}^2 - s_{\text{PM}}^2}{s_{\text{S}}^2} = \frac{s_{\text{I}}^2}{s_{\text{S}}^2} \quad (35)$$

where

s_{Iunc}^2 is the uncorrected increment variance;

s_{I}^2 is the primary increment variance;

s_S^2 is the required sampling variance.

b) Within sub-lot variance method

Rearranging equation (19) enables the number of increments to be calculated as follows:

$$n = \frac{s_{wsl}^2 - s_{PM}^2}{s_S^2} \quad (36)$$

where

s_{wsl}^2 is the within sub-lot variance.

Neither method can be used where the increment mass has been changed. The within sub-lot variance equation may be inaccurate if the interval between increments has been changed, but the increment variance equation can still be used in this case.

9 Masses of gross samples and sub-lot samples

9.1 General

It is essential to ensure that the mass of gross samples is sufficient to obtain the required sampling variance. The combination of the number and mass of increments determined in clause 8, subject to their being taken in an unbiased manner (see clause 7), will ensure that a sample of sufficient mass is collected at the primary sampling stage. However, during subsequent reduction and division of increments, sub-lot samples and gross samples, it is important to ensure that sufficient sample mass is retained at each stage so that the minimum gross sample mass is always exceeded.

Before the minimum gross sample mass can be determined, it is necessary to determine the fundamental error variance, s_F^2 , and to decide what value is acceptable. The fundamental error variance is one component of the short-range quality fluctuation variance, s_{Q1}^2 , and results from the particle-to-particle variation in quality (see 5.3.1). There is a minimum mass of gross sample required to achieve a given fundamental variance at any stage of sampling. The sample mass cannot be reduced below this minimum until the sample is crushed to a smaller particle size. A characteristic of s_F^2 is that it reduces quickly as the nominal top size is reduced.

9.2 Minimum mass of gross samples

9.2.1 Fundamental error

The fundamental error is the component of sampling error resulting from the variation in quality between particles. Several techniques are available to estimate the fundamental error variance, and hence the minimum gross sample mass m_G . Three are described below.

9.2.2 Fully experimental technique

The fully experimental technique is applicable to the determination of fundamental error for any required quality characteristic, for example chemical content, size, and physical tests.

Divide representative samples of bulk material into replicate samples of a given mass, and calculate the between-sample variance, s_{BS}^2 , from the measured quality characteristics. This variance is determined for a range of sample masses smaller than the gross sample masses proposed to be used. Masses smaller by a factor of 10 to 100 are useful. Express the variance, s_{BS}^2 , in terms of the nominal top size in millimetres (d) and the replicate gross sample mass in kilograms (m_g) according to the equation:

$$s_{\text{BS}}^2 = A_0 + \frac{A_F \cdot d^3}{m_g} \quad (37)$$

where

A_0 and A_F are constants determined from a least-squares fit to the experimental data.

The first term A_0 in equation (37) includes the preparation and measurement error variances and the grouping and segregation error variance, s_G^2 , and is independent of the gross sample mass m_g . The second term is the estimated fundamental error variance, i.e.

$$s_F^2 = \frac{A_F \cdot d^3}{m_g} \quad (38)$$

Hence, the minimum gross sample mass for the desired fundamental error variance is given by:

$$m_g = \frac{A_F \cdot d^3}{s_F^2} \quad (39)$$

EXAMPLE To illustrate equation (39) with an example, consider lump iron ore with $d = 22,4$ mm. The mineral is hematite (Fe_2O_3) and the gangue consists of silicates and shale. From a least squares fit to experimental data, a value of $A_F = 1,6 \times 10^{-9} \text{ kg}\cdot\text{mm}^{-3}$ (i.e. $1,6 \text{ kg}\cdot\text{m}^{-3}$) was determined. If it is specified that the fundamental error is not to exceed 0,05 % Fe or 0,07 % Fe_2O_3 , i.e. $s_F^2 = 0,0007$.

From equation (35):

$$m_g = \frac{1,6 \times 10^{-9} \times (22,4)^3}{(0,0007)^2} = 36,7 \text{ kg}$$

Thus the minimum sample mass for a nominal top size of 22,4 mm to achieve the above fundamental error is approximately 37 kg. The sample mass is to be crushed to a smaller nominal top size before the sample mass can be reduced any further. For example, if the 37 kg sample is passed through a jaw crusher to reduce the nominal top size to 3 mm, repeating the above calculation shows that the sample mass can then be safely reduced to 88 g.

9.2.3 Simplified calculations for materials with two components

For a material taken to consist of two components, the fundamental error variance of the percentage by mass of the key component is often approximated^[1] by the equation:

$$\hat{\sigma}_F^2 = \frac{\lambda \cdot f_{\text{comp}} \cdot f_s \cdot f_r \cdot d^3 \cdot w_k^2}{m_g} \times 10^{-6} \quad (40)$$

where

- $\hat{\sigma}_F^2$ is an estimate of the fundamental error variance of the mass fraction, expressed as percentage, of the key component, i.e. the component of the material which is of key interest, whereas the other, non-key component, may actually be an aggregation of a number of components of lesser interest or value. It is not an experimentally determined sampling variance, as the notation is meant to indicate, but is a theoretically based estimate of the fundamental error variance. However, it has been shown to be useful in a number of circumstances where little is known about a material to be sampled;
- λ is the liberation factor, i.e. a factor quantifying the degree of liberation of the constituent components from particles of the bulk material by crushing or grinding. λ equals $(d_\lambda/d)^{1/2}$ when liberation is incomplete, where d_λ is the nominal top size at which complete liberation occurs, and equals unity when liberation is complete;
- f_{comp} is the mineralogical composition factor, defined below in equation (41);
- f_s is the particle shape factor, which can usually be taken to be 0,5 (although for some materials it can range from 0,2 to 0,5);
- f_r is the size range factor defined as the ratio of the width of the aperture of the finest sieves (complying with ISO 565) through which pass 5 % and 95 %, respectively, of the mass of the material, with a value usually assumed to be between 0,25 and 1,0;
- d is the nominal top size, in millimetres, of the particles;
- w_k is the percentage by mass of key component;
- m_g is the gross sample mass, expressed in kilograms.

The mineralogical composition factor is defined as follows:

$$f_{\text{comp}} = \frac{100 - w_k}{100 w_k} \left[(100 - w_k) \rho_k + w_k \rho_{nk} \right] \quad (41)$$

where

- ρ_k is the density, expressed in tonnes per cubic metre, of the particles of the key component;
- ρ_{nk} is the density, expressed in tonnes per cubic metre, of the particles of the non-key component.

NOTE Equation (40) is obtained from the following equation [1]:

$$\hat{\sigma}_F^2 = \frac{c \cdot \lambda \cdot f \cdot g \cdot d^3 \cdot a^3}{m_g}$$

and differs from it only in the following respects:

- the units involved (kilograms and millimetres rather than grams and centimetres);
- the use of the absolute estimated variance $\hat{\sigma}_F^2$ rather than the relative estimated variance used in reference [1];
- the symbols f_{comp} , f_s , f_r and w_k are used in equation (40) instead of c , f , g and a respectively used in reference [1].

The size range factor f_r can be estimated from the ratio d/d_L of the nominal top size d to the lower size limit d_L (about 5 % undersize), as follows:

- large size range ($d/d_L > 4$) $f_r = 0,25$;
- medium size range ($2 \leq d/d_L \leq 4$) $f_r = 0,50$;
- small size range ($d/d_L < 2$) $f_r = 0,75$;
- uniform size ($d/d_L = 1$) $f_r = 1,00$.

Rearranging equation (40) gives the minimum gross sample mass for the desired fundamental error variance as follows:

$$m_g = \frac{\lambda \cdot f_{\text{comp}} \cdot f_s \cdot f_r \cdot d^3 \cdot w_k^2}{\hat{\sigma}_F^2} \times 10^{-6} \quad (42)$$

NOTE For the purpose of recalculating the variogram intercept for a different increment mass in accordance with 5.3.2, A_F in equation (12) is equal to $\lambda f_{\text{comp}} f_s f_r w_k^2 \times 10^{-6}$ in equation (42).

The estimate of the fundamental error variance given in equation (40) is given by a function which includes several mineralogical factors which are stochastic variables each with its own variance. It is difficult to guarantee that the estimate for the fundamental error calculated from this equation is unbiased. The equation is used to provide a preliminary estimate of the fundamental error without confidence limits. With those reservations in mind, the equation has in practice provided useful initial estimates in situations where little information was available.

9.2.4 Alternative fully experimental method

In this method, the fundamental error is measured directly by analysing a number of individual material fragments (or pellets, pisolites or other fractions) within an appropriate size range.

This method is applicable where experimental evidence shows that the quality characteristic of the material determined for a size-density fraction and the proportion of this size-density fraction in the lot vary little with the size of fragments. It is especially useful in situations where it is difficult or impossible to define the liberation size for the particles of a bulk material (for example, in the case of pisolitic manganese ore) which restricts the direct use of the fundamental error equation in reference[1], or when the material fragments tend to have similar proportions of the various components present (such as bauxites).

The procedure is the following.

- a) Select J individual particles of the bulk material (where J is about 50) from the coarsest size range of a sample having mass m . The numerical value of m , or even the physical definition of the sample, are not critical in this context; only the measured or estimated percentage of particles in the size range selected will be required, as shown in step i).

NOTE The size range is loosely defined as $d/2$ to d , with d being the nominal top size. Individual pieces may conveniently be selected from appropriate screen fractions. Alternatively, larger particles can be chosen by visual estimation which is quite adequate for this purpose.

The selection of coarser pieces for this kind of test is due to the fact that smaller size classes contribute no significant error component to the overall uncertainty.

- b) Dry the selected particles separately.
- c) Measure the dry mass m_j of each particle ($j = 1, 2, \dots, J$).
- d) Pulverize each of the particles to obtain separate test portions ready for analysis.

- e) Determine the quality characteristic, x_j , of each particle.
- f) Calculate the combined dry mass of the particles, m_{sel} , as follows:

$$m_{\text{sel}} = \sum_{j=1}^J m_j$$

where the subscript "sel" denotes the selection from the size range shown in step a).

- g) Calculate the mass-weighted average of the quality characteristic x_m :

$$x_m = \frac{\sum_{j=1}^J (x_j \cdot m_j)}{m_{\text{sel}}}$$

- h) Calculate the heterogeneity index H_S for the size range of the bulk material as follows:

$$H_S = \frac{\sum_{j=1}^J (x_j - x_m)^2 \cdot m_j^2}{x_m^2 \cdot m_{\text{sel}}}$$

- i) Evaluate the mass proportion m_H/m , where m_H is an estimate of the mass of particles in the size range $d/2$ to d . For example, a consignment containing an estimated 50 % of larger particles would result in a mass proportion $m_H/m = 0,50$.
- j) Calculate the heterogeneity index H of the bulk material which quantifies the heterogeneity of the material as follows:

$$H = H_S \frac{m_H}{m}$$

- k) Calculate the relative variance s_{rel}^2 using the equation:

$$s_{\text{rel}}^2 = \frac{H}{m}$$

Hence the relative standard deviation is:

$$s_{\text{rel}} = \sqrt{\frac{H}{m}}$$

NOTE The applicable value of m (expressed in grams) can be varied according to the intended mass of the divided sample. By calculating s_{rel} for a range of values m , it is possible to adjust the sample mass so as to achieve a given precision.

- l) Calculate the absolute standard deviation of the fundamental error, s_F , using the equation:

$$s_F = s_{\text{rel}} \cdot x_m$$

The values of s_F and x_m have identical units, and s_F is a measure of the standard deviation of the fundamental error.

EXAMPLE The procedure is demonstrated by an example using results for five individual manganese ore fragments given in Table 3. It is stressed that a proper assessment requires about 50 pieces to be tested.

Table 3 — Experimental results for manganese ore fragments

Particle mass	Grade
$m_1 = 155$ g	$x_1 = 50,8$ % Mn
$m_2 = 107$ g	$x_2 = 46,9$ % Mn
$m_3 = 212$ g	$x_3 = 52,0$ % Mn
$m_4 = 99$ g	$x_4 = 49,9$ % Mn
$m_5 = 134$ g	$x_5 = 47,8$ % Mn
Results	
$m_H = 707$ g	
$x_m = 49,9$ % Mn	
$H_S = 0,229$	
$H = 0,114$ (assuming $m_H/m = 0,50$)	

The resulting error levels as a function of the sample mass are shown in Table 4.

Table 4 — Error levels versus sample mass

Sample mass m g	Relative variance s_{rel}^2	Relative standard deviation s_{rel}	Absolute standard deviation s % Mn
100	0,001 140	0,033 8	1,69
500	0,000 229	0,015 1	0,75
1 000	0,000 114	0,010 7	0,53
2 500	0,000 046	0,006 8	0,34
5 000	0,000 023	0,004 8	0,24
10 000	0,000 011	0,003 4	0,17
25 000	0,000 005	0,002 1	0,10

9.3 Minimum mass of sub-lot samples

It is essential that the combined mass of all sub-lot samples that are prepared for the lot are, at each stage, greater than the minimum mass of the gross sample defined in 9.2.

9.4 Minimum mass of crushed gross samples and sub-lot samples

Where gross samples and sub-lot samples are crushed to permit further division, recalculate the minimum masses as specified in 9.2.2 for the nominal top size of the crushed material using equation (39). Where preliminary estimates of the minimum masses for crushed samples are desired, the calculation method given in 9.2.3 can be used.

10 Mass-basis sampling

10.1 General

Mass-basis sampling involves the following steps:

- a) spread the number of primary increments required on a uniform mass basis throughout the lot to be sampled;
- b) extract from each mass interval an almost uniform mass of bulk material [at either the primary (preferred) or secondary division step] to give an almost uniform mass of sample reporting to the gross sample or sub-lot sample.

NOTE "Almost uniform mass" means that the coefficient of variation of the increment masses is not greater than 20 %. For example, where the nominal mass of increments is to be 40 kg, the increments are taken in such a manner that 95 % of the increments vary between 24 kg and 56 kg, with an average of 40 kg.

Mass-basis sampling will produce biased results if there is a correlation between flow rate and quality and also if there is a correlation between flow rate and increment mass, even if the increment masses conform to the restrictions given above. To use mass-basis sampling correctly, it is important to install sampling equipment capable of obtaining properly fixed mass increments for which there is no significant correlation between increment mass and flow rate.

10.2 Sampling interval

Determine the interval between taking primary increments by mass-basis sampling using the following equation:

$$\Delta m \leq \frac{m_{\text{lot}}}{n} \quad (43)$$

where

Δm is the mass interval, in tonnes, between taking primary increments;

m_{lot} is the mass, in tonnes, of the lot;

n is the number of primary increments determined in 8.2.

10.3 Cutters

The following cutters may be used:

- a) a falling-stream cutter whose cutting speed is fixed during the course of handling the entire lot;
- b) a falling-stream cutter whose cutting speed is constant while cutting the stream but can be regulated, primary increment by primary increment, according to the flow rate of the bulk material on the conveyor belt;
- c) a cross-belt cutter.

10.4 Taking of primary increments

Each primary increment is taken by a single traverse of the sampling device so that a full cross-section of the stream is sampled.

The first primary increment is taken at a random mass less than Δm from the start of a lot. Thereafter, the required number of primary increments is taken by systematic sampling on a mass basis, i.e. at a fixed mass interval (Δm), and this interval is not changed during the entire course of sampling of a lot.

NOTE The mass interval between primary increments should be smaller than that calculated in 10.2, so as to ensure that the number of primary increments to be taken will be larger than the minimum number required.

Where the planned number of primary increments has been taken and handling of the lot has not been completed, take additional primary increments at the same mass interval until the handling operation is completed.

10.5 Constitution of a gross sample or sub-lot sample

A gross sample comprises all primary increments or sub-lot samples, either as taken or after having been prepared individually to a particular stage of sample preparation and then combined in the correct proportions.

Where the coefficient of variation of the masses of primary increments is greater than 20 %, do not combine the primary increments, as taken, into sub-lot samples or a gross sample and either:

- a) subject each primary increment separately to division (according to the rules of division) and determine its quality characteristics; or
- b) subject primary increments to constant-mass division prior to combining them into sub-lot samples or a gross sample.

A sub-lot sample comprises several consecutive primary increments, either as taken or after having been prepared individually to a particular stage of sample preparation and then combined in the correct proportions. Each of a series of sub-lot samples for a lot should be made up of an equal number of consecutive primary increments. If it is not practical to obtain sub-lot samples made up of an equal number of increments, weight the results according to sub-lot masses.

10.6 Methods of division

Constant-mass division is a method of obtaining divided increments, sub-lot samples or gross samples having almost uniform mass, regardless of the variation in the masses to be divided. Cutter-type dividers having variable cutting frequencies can be used for this type of division.

Fixed-rate division is a method of obtaining divided increments, sub-lot samples or gross samples having masses proportional to the varied masses to be divided. Rotary sample dividers or slotted belts can be used for this type of division.

10.7 Division of increments

Where increments are divided and sub-lot samples or a gross sample are constituted from such divided increments, carry out the division by one of the following methods.

- a) If the coefficient of variation of the masses of increments is greater than 20 %, carry out the division on an increment by increment basis using constant-mass division.
- b) If the coefficient of variation is not greater than 20 %, use either constant-mass or fixed-rate division.

10.8 Division of sub-lot samples

Where sub-lot samples are divided and a gross sample is constituted from the divided sub-lot samples, carry out the division by one of the following methods.

- a) If the coefficient of variation of the masses of sub-lot samples is not greater than 20 % and the sub-lot samples consist of an equal number of increments, use either constant-mass or fixed-rate division.
- b) If the coefficient of variation of the masses of sub-lot samples is greater than 20 % from their mean, and the sub-lot samples consist of an equal number of increments, use constant-mass division.
- c) If the sub-lot samples consist of different numbers of increments, use fixed-rate division so as to maintain correct weighting.

If fixed mass sub-samples are removed from a sub-lot sample (e.g. for a moisture test), then take into account any combination of the rest of the sub-lot sample for correct weighting.

10.9 Division of gross samples

Where gross samples are divided, use either constant-mass or fixed-rate division.

10.10 Number of cuts for division

Determine the minimum number of cuts and their minimum masses for the division of increments, sub-lot samples and gross samples experimentally as specified in 5.3 and clauses 8 and 9.

However, as a general guide, the following numbers of cuts may be used.

- a) **For gross samples:** use a minimum of 20 cuts. The combined mass of the cuts should be greater than the minimum gross sample mass specified in 9.2 and 9.4;
- b) **For sub-lot samples:** use a minimum of 10 cuts. The combined mass of the cuts from all sub-lot samples at a given sampling stage should be greater than the minimum gross sample mass specified in 9.2 and 9.4;
- c) **For individual increments:** use a minimum of four cuts at each sampling stage. The combined mass of the cuts from all increments at a given sampling stage should be greater than the minimum gross sample mass needed to obtain the required sampling variance. Calculate this minimum gross sample mass using the methods specified in 9.2 and 9.4.

Since the sampling precision cannot be determined beforehand, check experiments are recommended to ascertain whether the number of cuts is sufficient.

For constant-mass division, vary the interval between taking cuts according to the mass of the gross sample, sub-lot sample or increment to be divided in accordance with the principles specified in 10.2. Take the first cut at random within the first mass interval.

For fixed-rate division, keep the interval between taking cuts constant regardless of the mass of the gross sample, sub-lot sample or increment to be divided, in accordance with the principles specified in 11.2. Take the first cut at random within the first time interval.

11 Time-basis sampling

11.1 General

Time-basis sampling involves the following two steps:

- a) distribution of the required number of primary increments, on a uniform time basis, throughout the mass to be sampled;
- b) for each time interval, extraction of a primary increment of particulate material proportional to the material flow rate at the time of taking the increment.

11.2 Sampling interval

The interval between taking primary increments by time-basis sampling is as follows:

$$\Delta t < \frac{60 m_{\text{lot}}}{q \cdot n} \quad (44)$$

where

Δt is the time interval, in minutes, between taking primary increments;

m_{lot} is the mass, in tonnes of the lot;

q is the maximum flow rate, in tonnes per hour;

n is the number of primary increments determined in 8.2.

11.3 Cutters

The following cutters may be used:

- a) a falling-stream cutter, whose cutting speed is fixed during the course of handling the entire lot;
- b) a cross-belt cutter.

11.4 Taking of primary increments

Take each primary increment by a single traverse of the sampling device.

Take the first primary increment at a random time after a period of time of less than Δt from the start of the lot. Thereafter, take the required number of primary increments using stratified systematic sampling on a time basis, i.e. at a fixed time interval that is not changed during the entire course of sampling of a lot.

NOTE The time interval between primary increments should be smaller than that calculated in 11.2 to ensure that the number of primary increments to be taken will be larger than the minimum number of primary increments specified.

Where the planned number of primary increments has been taken and the handling has not been completed, take additional primary increments at the same interval until the handling operation is completed.

11.5 Constitution of gross sample or sub-lot sample

Combine primary increments to form gross samples or sub-lot samples in either of the following ways.

- a) Combine primary increments, as taken, into sub-lot samples or a gross sample irrespective of the variation of masses of primary increments.

NOTE When sub-lot samples are analysed to determine the quality characteristics for the lot, the mass of the sub-lot sample, or the mass of the sub-lot from which the sub-lot sample has been taken, should be determined in order to obtain the weighted mean of the quality characteristic for the lot.

- b) Divide primary increments using fixed-rate division. Then prepare a gross sample or sub-lot sample by combining divided increments, provided that the mass of the divided increment is proportional to that of the primary increment, so as to retain the weighted mean of the quality characteristic for the lot.

11.6 Division of increments and sub-lot samples

After time-basis sampling, carry out the division of increments and sub-lot samples using fixed-rate division where the divided samples are intended to be combined. When samples are not intended to be combined, fixed-rate division or constant-mass division can be used.

11.7 Division of gross samples

Carry out division of gross samples by either constant-mass or fixed-rate division.

11.8 Number of cuts for division

Determine the minimum number of cuts and their minimum masses for division of increments, sub-lot samples and gross samples experimentally as specified in 5.3 and clauses 8 and 9.

However, as a general guide, the following numbers of cuts may be used.

- a) **For gross samples:** use a minimum of 20 cuts. The combined mass of the cuts should be greater than the minimum gross sample mass specified in 9.2 and 9.4.
- b) **For sub-lot samples:** use a minimum of 10 cuts. The combined mass of the cuts from all sub-lot samples at a given sampling stage should be greater than the minimum gross sample mass specified in 9.2 and 9.4.
- c) **For individual increments:** use a minimum of four cuts. The combined mass of the cuts from all increments at a given sampling stage should be greater than the minimum gross sample mass specified in 9.2 and 9.4.

Since the sampling precision cannot be determined beforehand, check experiments are recommended so as to ascertain whether the number of cuts is sufficient.

For fixed-rate division, keep the interval between taking cuts constant regardless of the mass of the gross sample, sub-lot sample or increment to be divided in accordance with the principles of 11.2. Take the first cut at random within the first time interval.

12 Stratified random sampling within fixed mass or time intervals

For stratified random sampling within fixed mass intervals, use the procedure specified in clause 10, with the exception that once the mass interval has been set, programme the sample cutter to take one primary increment at any point at random within this mass interval. For this purpose, use a random number generator, capable of giving a random mass number anywhere within the mass interval (determined in 10.2), which activates the sample cutter at the mass corresponding to the mass number generated.

For stratified random sampling within fixed time intervals, use the procedure specified in clause 11, with the exception that once the time interval has been set, programme the sample cutter to take one primary increment at any point at random within this time interval. For this purpose, use a random number generator, capable of giving a random time number anywhere within the time interval (determined in 11.2), which activates the sample cutter at the time corresponding to the time number generated.

13 Mechanical sampling from moving streams

13.1 General

Different mechanical sample cutters are available and it is not possible to specify any particular type that should be used for specific sampling applications.

NOTE Annex B gives examples of sample cutters in common use and should be taken as a guide in the choice of suitable equipment.

Only mechanical samplers that take a complete cross-section of the bulk material stream in one cut are recommended. Mechanical sample cutters taking only a part of the stream in one operation do not collect a representative sample and, therefore, do not comply with this part of ISO 11648.

13.2 Design of the sampling system

13.2.1 Safety of operators

From the initial stage of design and construction of a sampling system, ensure that consideration is given to the safety of operators. Respect the applicable safety codes prescribed by the appropriate regulatory authorities.

13.2.2 Location of sample cutters

Choose the location of sample cutters according to the following criteria:

- a) ensure the sample cutters are located at a point which affords access to the complete bulk material stream;
- b) perform sampling as closely as possible to the loading or discharge point where the quality characteristics are to be determined, for example immediately prior to ship loading;
- c) perform sampling at a point in the handling system where there is no apparent visual segregation of the material stream and where there is no apparent risk of errors due to a periodic variation in material feed or quality.

NOTE 1 Basic requirements should be taken into account from the early stages of design, construction and installation of the system as well as during the operation and maintenance of the plant. To permit bias checks, provision should be made for stopped-belt sampling adjacent to the sample cutter.

NOTE 2 It is not essential to construct or operate the mechanical sampling system as a whole. Any principal unit, or combination of principal units, may be operated mechanically and combined at any stage with manual procedures.

13.2.3 Provision for duplicate sampling

It is recommended that the system provided be capable of processing each primary increment to constitute duplicate sub-lot samples.

13.2.4 System for checking the precision and bias

When a mechanical sampling system is commissioned or when principal parts are modified, check the system to ensure that correct sampling principles are respected. Also carry out check experiments for precision and bias for the system as a whole.

Verify the level of bias, preferably by comparison with "stopped-belt" sampling, using the critical properties in the operation of the sampling system.

13.2.5 Avoiding bias

It is essential that the sampling system be designed to avoid the following:

- spillage of the sample;
- restriction of the flow of bulk material through the system;
- retention of residual material;
- contamination of the sample.

NOTE When a change is made in the type of bulk material being sampled, the system should be thoroughly cleaned, or a quantity of material taken from the lot to be sampled should be passed through the entire system to remove any contaminants.

13.2.6 Minimizing bias

It is essential that the sampling system be designed to minimize the following:

- degradation of the constituent particles where a sample is taken for size determination;
- change in moisture content.

13.2.7 Arrangement of sampling system

Arrange the sampling system in such a way that the principal units can be operated individually.

In the event of breakdown in the crushing and dividing parts of the system, make sure provision is made to be able to carry out sampling manually. For example, increments taken by the primary sampler may be by-passed to a pre-installed facility (e.g. short conveyor, concrete pad or base with smooth working surface, receiving truck) so that sample preparation can proceed.

13.3 Sample cutters

13.3.1 General

Sample cutters are divided into two types. Falling-stream cutters collect the increment from the stream trajectory of the bulk material, for example at a transfer point, or discharge into or from a bin or hopper. Cross-belt cutters collect the increment from the material stream while it is being conveyed on a conveyor belt.

13.3.2 Falling-stream cutters

In designing falling-stream cutters, the following criteria apply.

- a) The sample cutter shall be of the self-clearing type, for example stainless-steel or polyurethane lined, discharging each increment completely.
- b) No materials other than the sample shall be introduced into the cutter, for example to prevent any dust from accumulating in the cutter when in the parked position.
- c) The cutter shall collect a complete cross-section of the bulk material stream, both the leading and trailing edges clearing the stream in the same path.
- d) The angle between the cutter aperture and the horizontal should preferably be half the angle between the bulk material stream and the vertical, within 30° (see Figure 5). Alternatively, the cutter may cut the stream either in a plane normal to, or along an arc normal to, the mean trajectory of the stream. Cutters in which the plane of the aperture is vertical, or nearly vertical, shall be avoided.
- e) The cutter shall travel through the bulk material stream at a uniform velocity, not deviating by more than 5 % at any point.
- f) The geometry of the cutter opening shall be such that the cutting time of each point in the stream is nearly equal, not deviating by more than 5 %, i.e. straight-path cutters should have parallel cutter lips, and radial cutters should have radial cutter lips.
- g) The effective cutting aperture width of the cutter shall be at least three times as large as the nominal top size of the bulk material being sampled (see Figure 6).
- h) The minimum cutter aperture width of any cutter shall be 30 mm.

NOTE Where experimental evidence is available to show that no significant bias is introduced, cutter aperture widths as small as 10 mm may be used for most materials. In the case of free flowing mineral sands, experimental evidence shows that no significant bias is introduced for a minimum cutter aperture width as small as 4 mm.

- i) The cutter shall be of sufficient capacity to accommodate the increment mass obtained at the maximum flow rate of the bulk material.

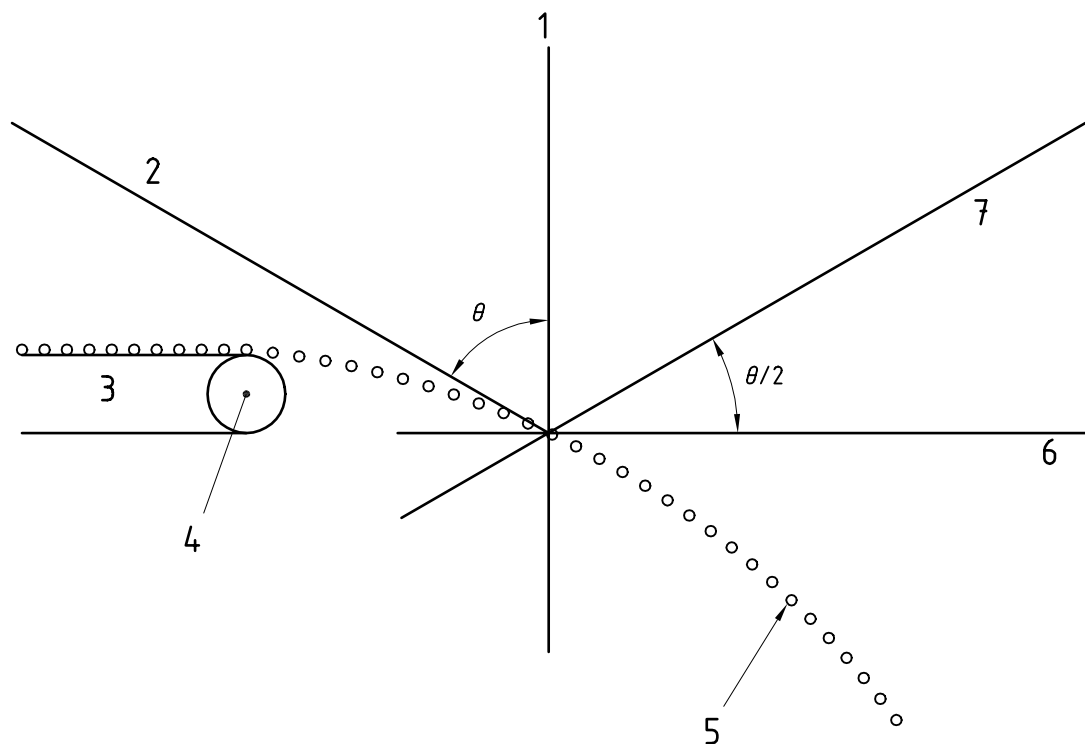

Key

- 1 Vertical plane
- 2 Mean direction of material particles as they reach the plane of the cutter aperture
- 3 Conveyor
- 4 Head pulley
- 5 Mean trajectory of material particles
- 6 Horizontal plane
- 7 Plane of cutter aperture

θ = angle between the material stream and the vertical

$\frac{\theta}{2}$ = angle between the plane of the cutter aperture and the horizontal

Figure 5 — Falling-stream sample cutter

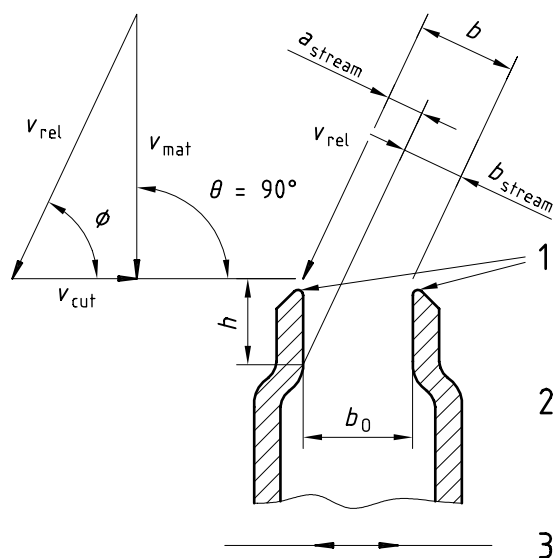

Key

- 1 Cutting edges
- 2 Cutter lips
- 3 Cutter path

a_{stream}	= the width of the zone of partially impeded stream	v_{mat}	= velocity of the material stream
b_{stream}	= the width of the zone of unimpeded stream	b	= effective cutter aperture width
h	= the depth of the cutter throat	b_0	= the width of the cutter
v_{cut}	= velocity of the cutter	θ	= angle between material stream and cutter path
v_{rel}	= relative velocity	ϕ	= angle between relative velocity and direction of cutter path

Figure 6 — Cutter having cutter lips normal to the cutter path

13.3.3 Cross-belt cutters

In designing cross-belt cutters, the following criteria apply.

- a) The sample cutter shall be of the self-clearing type, for example stainless-steel or polyurethane lined, discharging each increment completely.
- b) No materials other than the sample shall be introduced into the sample cutter, for example, to prevent any dust from accumulating in the cutter when in the parked position.
- c) The cutter shall collect a complete cross-section of the bulk material stream.
- d) The cutter shall cut the bulk material stream in a plane normal to the surface of the conveyor.
- e) The cutter shall travel through the bulk material stream at a uniform velocity, not deviating by more than 5 % at any point.
- f) The geometry of the cutter opening shall be such that the cutting time of each point in the stream is nearly equal, not deviating by more than 5 %.
- g) The effective cutting aperture width of the cutter shall be at least three times as large as the nominal top size of the bulk material being sampled.

- h) The minimum cutter aperture width of any cutter shall be 30 mm.

NOTE Where experimental evidence is available to show that no significant bias is introduced, cutter aperture widths as small as 10 mm may be used for most materials. In the case of free flowing mineral sands, experimental evidence shows that no significant bias is introduced for a minimum cutter aperture width as small as 4 mm.

- i) The cutter shall be of sufficient capacity to accommodate the increment mass obtained at the maximum flow rate of the bulk material.
- j) To ensure that all fine particles are collected from the belt, adjust the profile of the conveyor belt to the curvature of the path of the cutter by additional multi-roller idlers.
- k) Regularly adjust any flexible blades, brushes or skirts fitted to the cutter so as to maintain their close contact with the surface of the moving conveyor belt and to ensure that the complete bulk-material section in the path of the cutter is collected from the belt.

13.3.4 Cutter velocities

In designing a mechanical sample cutter, one of the most important design parameters is the cutter velocity. Too high a cutter velocity will lead to:

- biasing of the sample due to deflection of the larger particles;
- biasing of the sample by rebounding particles and dust caused by excessive turbulence;
- shock load problems and difficulties in maintaining constant speed while cutting the material stream.

For falling-stream cutters, experimental work on ores^[1] has shown that when sampling heterogeneous material streams of low belt loading (stream density) where the particle size distribution is very narrow, significant bias may be introduced if the cutter speed exceeds 0,6 m/s or the cutter aperture width is less than three times as large as the nominal top size of the material.

On the basis of this evidence, falling-stream cutters that have a cutter aperture width, b , equal to three times as large as the nominal top size of the bulk material shall not exceed a cutter speed of 0,6 m/s.

For falling-stream cutters where the effective aperture width is greater than three times the nominal top size, the maximum cutter speed allowed can be increased in accordance with the following equation:

$$v_{\text{cut}} = 0,3 \left(1 + \frac{b}{3d} \right) \quad (45)$$

where

v_{cut} is the maximum cutter speed allowed, in metres per second;

b is the effective aperture width, in millimetres, of the cutter;

d is the nominal top size, in millimetres.

However, it is imperative that the maximum speed not exceed 1,5 m/s.

NOTE In cases where the cutter aperture width is three times as large as the nominal top size, cutter speeds higher than 0,6 m/s may be used only where experimental evidence proves that no significant bias is introduced.

When sampling from a moving conveyor belt using a cross-belt cutter, take the increments from the complete width of the belt at right angles to the stream or at an angle to the stream axis so that the cutter does not create a "bow wave". The peripheral speed shall be such that no excessive turbulence is created and shall be a minimum of 1,5 times belt speed.

13.4 Mass of increments

The mass of each increment obtained from a falling-stream sampler designed to avoid bias is given in clause 7.

13.5 Number of primary increments

The number of primary increments taken is given in clause 8.

13.6 Routine checking

Carry out the maintenance and inspection of the sampling system, particularly cutter apertures, at frequent and regular intervals. Carry out the verification of compliance with appropriate standards when any modifications are made or a change is suspected. Check the average increment mass to ensure that it is consistent with the mass predicted by equations (26) or (27).

14 Manual sampling from moving streams

14.1 General

Mechanical sampling from moving streams is the recommended method because it provides more reliable data than manual sampling. However, where no mechanical sampler is available or where it is considered that mechanical sampling equipment may produce undue size degradation, manual sampling may be performed, provided that access is available to the complete material stream and that there is no risk for the safety of the operator.

For safety reasons, also restrict manual sampling from moving streams to streams with small flow rates (see 14.2). In relation to the safety of operators, respect the applicable safety codes prescribed by the appropriate regulatory authorities.

In order to obtain a fully representative sample, access to the whole stream is necessary. In some situations it may be possible to use the reference method from a stopped belt (see clause 15).

14.2 Choosing the sampling location

The sampling location shall:

- provide complete operator safety;
- afford access to the complete bulk material stream;
- enable minimum segregation of the bulk material stream, for example in particle size distribution and moisture distribution;
- be as close as possible to the load or discharge point where the quality is to be determined.

In most conveying systems, the only sampling location that satisfies the above criteria is at a transfer or discharge point. No sampling is permitted from the top of a moving conveyor belt for reasons primarily concerned with the safety of the operator and secondly due to the difficulty in obtaining an unbiased sample.

Manual sampling from moving streams is only practicable in cases where the flow rate is slow enough to be able to physically collect a complete cross-section of the stream of particulate material. Sampling of parts of the stream is not recommended because particulate material very often segregates on a conveyor belt. Furthermore, for safety reasons, do not attempt to make a sampling from a falling stream if the flow rate exceeds 250 t/h.

14.3 Sampling implements

Carry out manual sampling from moving streams of particulate material using implements such as ladles, scoops or manual sample cutters. Use an implement having an opening no less than three times the nominal top size of the particulate material and having a capacity so as to sample the complete stream in one pass.

NOTE Examples of suitable implements for manual sampling are given in annex C.

Make sure the capacity of the implement is designed to avoid overflow and conforms with the recommendations of clause 9 and Figure C.1.

14.4 Mass of increments

The mass of each increment obtained from a manual-sampling implement designed to avoid bias is given in clause 7.

14.5 Number of primary increments

The number of primary increments to be taken is given in clause 8.

14.6 Sampling procedures

Take the increment in a single operation, moving the ladle, scoop or manual sample cutter across the full width of the stream of particulate material at a uniform rate. Take alternate increments by crossing the stream in opposite directions.

When using a scoop, invert the implement so as to place the opening underneath the stream of particulate material, then insert it through the stream to the other side. Turn the scoop upright again and withdraw it through the stream. Alternatively, the scoop may be filled by passing it through the stream once, from front to rear, provided that it subsequently can be withdrawn from the stream. Whatever method is used, it is essential that the increment not fill the sample container after it has traversed the stream.

15 Stopped-belt sampling

For collecting a reference sample, stopped-belt sampling is the preferred method in comparison with other sampling procedures. The procedure for sampling from a stopped belt is as follows.

- a) Determine the parameters for sampling.
- b) Stop the belt at the predetermined time or mass intervals.
- c) At each stoppage, place a suitably profiled sampling frame (see Note 1), with minimum internal dimensions of three times the nominal top size of the bulk material or 30 mm, whichever is the larger, on the stationary belt and insert it through the material so that it is in intimate contact with the belt across its full width.
- d) Should any large pieces of bulk material prevent insertion of the frame, push those at the left-hand edge of the frame into the increment and those at the right-hand edge of the frame out of the increment.
- e) Remove the bulk material within the sampling frame, ensuring that all particles in this area are included in the increment by sweeping the belt, and deposit each increment into a suitable container (see Note 2).
- f) Combine the increments as follows.
 - 1) For time-basis sampling, combine the increments as taken into sub-lot samples or a gross sample, irrespective of the variation in the masses of the increments. If the masses of the increments are too large, divide the increments by fixed-rate division prior to combination.

- 2) For mass-basis sampling, if the coefficient of variation of increment masses is greater than 20 % from their mean, do not combine the increments as taken into sub-lot samples or a gross sample; either divide each increment separately and determine its quality characteristics, or divide increments by constant-mass division prior to combination at the appropriate stage of division into sub-lot samples or a gross sample.
- g) Store the sub-lot samples or gross samples in labelled containers as specified in clause 23.

NOTE 1 An example of a suitable sampling frame is given in annex D.

NOTE 2 Where the increment is to be used for moisture determination, the increment should be removed from within the sampling frame in the shortest possible time to prevent loss of moisture, and deposited together with the belt sweepings in a container which should be promptly sealed to prevent moisture loss (or gain) due to climatic conditions.

16 Sampling from stationary situations

16.1 General

This clause sets out procedures for sampling bulk material from railway wagons, road wagons, shallow barges, ships' holds, large barges, and stockpiles.

The methods of sampling described in this clause are aimed at obtaining the best sample that can be achieved in the circumstances. It should be borne in mind, however, that when sampling from stationary lots, circumstances are far from ideal for sampling. The essential condition of sampling, namely that all parts of the bulk material shall be equally accessible to the sampling implement and have the same chance of being included in the sample, can only be fulfilled in a limited number of stationary lot sampling procedures.

There is a risk that considerably biased samples can be taken because stationary bulk materials tend to be highly segregated. Consequently, sampling from the surface of wagons is not included in this clause. Of even greater concern, there is a considerable risk to the safety of operators taking samples from the tops of wagons, given the possibility of the wagons moving during the operation.

Sampling from stationary lots should therefore only be applied if no possibility exists of using the recommended method of sampling, namely sampling from a moving stream with a cutter during the loading or unloading from wagons, barges, ships or stockpiles.

16.2 Establishing a sampling scheme

The general procedure for sampling from stationary lots is similar to that outlined for sampling from moving streams (clause 6), although there are some specific differences. For stationary situations, the following shall be the general procedure for establishing a sampling scheme.

- a) Define the purpose for which the samples are to be taken.
- b) Identify the quality characteristics to be measured and the types of samples required. Specify the total precision (combined precision of sampling, sample preparation and measurement) required for each quality characteristic.
- c) Define the lot and the number of sub-lots (u_{lot}) if such a division is required. A lot may be sampled as a whole or as a series of sub-lots. A division of a lot into a number of sub-lots may be necessary in order to improve the precision of the results.
- d) Decide whether continuous or intermittent sampling is to be used (16.3 and 16.4).
- e) Determine the variability of the quality characteristic under consideration using the methods of 5.3 and establish the number of sub-lots (u_{sub}) (16.4) actually to be sampled in order to attain the desired precision.
- f) Divide each sub-lot to be sampled into n_{sub} strata (n_{sub} being the number of increments to be taken per sub-lot as specified in 16.5). These strata are to be spaced evenly by position or mass.

- g) Ascertain the nominal top size and particle density of the bulk material for use in determining the gross sample mass in step i). The nominal top size also determines the minimum size of the opening of the sampling implement required to avoid bias.
- h) Check that the procedures and equipment for taking increments avoid significant bias.
- i) Determine the minimum gross sample mass (clause 9).
- j) Determine the method of combining the increments into samples and the method of sample preparation.

Carry out the sampling by stratified systematic sampling, but only where it can be shown that no systematic error can be introduced by any periodic variation in quality or quantity which may coincide with, or approximate to, any multiple of the proposed sampling interval.

Where there is a risk that systematic errors can be introduced by periodic variations in quality or quantity, it is suggested that stratified random sampling be used.

In some cases, if all increments are to be combined, the total mass will be so large that division of the increments becomes necessary prior to combination to form sub-lot samples or a gross sample. In such cases, follow the procedure for manual increment division.

All primary increments taken for combining into gross samples or sub-lot samples should be of almost uniform mass; i.e. the coefficient of variation of the increment masses should not be greater than 20 %.

16.3 Continuous sampling

In continuous sampling, sample every sub-lot and collect the same number of increments from each sub-lot. There are as many sample results for the lot as there are sub-lots. The mean result for the lot should be of the required precision but if it is desired to check that the required precision has been obtained, it is possible to do so by using the procedures of replicate sampling described in ISO 13909-7.

16.4 Intermittent sampling

It may be satisfactory to collect increments from some of the sub-lots of a bulk material but not from others. This is called intermittent sampling. Take the same number of increments from every sub-lot that is sampled. Choose the sub-lots to be sampled at random, unless it can be demonstrated that no bias, for example as a result of time-dependent variance, is introduced by choosing sub-lots systematically. It is recommended that such a demonstration be repeated from time to time and at random intervals.

There are as many sample results as there are sub-lots sampled, but because some sub-lots are not sampled, it is not possible to say whether the average of these results will have the required precision for the lot unless information about the variation between sub-lots is available. This can be obtained by following the procedure described in ISO 13909-7. If the variation between sub-lots is too large, it may be necessary to introduce continuous sampling to achieve the desired precision.

16.5 Overall precision and the number of increments.

The required overall precision $2s_{\text{SPM}}^2$ for a lot shall be decided for each quality characteristic to be measured. From an experimental determination of the sample preparation and measurement variance, s_{PM}^2 , and the required overall precision, the required sampling variance s_{S}^2 can be derived, provided $s_{\text{SPM}}^2 > s_{\text{PM}}^2$.

The minimum number of increments for the lot, n_{lot} , that need to be taken in order to achieve a required sampling variance, may be determined using the methods for estimating the variability of the quality characteristic that are described in clause 8.

ISO 11648-2:2001(E)

If the increment variance method is used to estimate variability, then equation (35) may be written as:

$$n_{\text{lot}} = \frac{s_1^2}{s_S^2} \leq u_{\text{sub}} \cdot n_{\text{sub}} \quad (46)$$

where

n_{sub} is the number of increments taken from each sub-lot sampled in either an intermittent or continuous sampling scheme;

u_{sub} is the number of sub-lots actually sampled in an intermittent sampling scheme and selected from the sub-lots of the lot.

If u_{sub} sub-lot samples are prepared with each sub-lot sample being constituted with an equal number, n_{sub} , of increments and if single measurements ($r = 1$) are carried out on each sub-lot sample, then a generalized form of equation (24) appropriate for intermittent sampling is required. That is:

$$s_{\text{Iunc}}^2 = s_S^2 + \frac{s_{\text{sub}}^2}{u_{\text{sub}}} - \frac{s_{\text{sub}}^2}{u_{\text{lot}}} + \frac{s_{\text{PM}}^2}{u_{\text{sub}}} \quad (47)$$

where

s_{sub}^2 is the sub-lot variance which may be determined by the methods described in ISO 13909-7;

u_{lot} is the number of sub-lots in the lot.

For continuous sampling where $u_{\text{sub}} = u_{\text{lot}}$, equation (47) simplifies to:

$$s_{\text{SPM}}^2 = s_S^2 + \frac{s_{\text{PM}}^2}{u_{\text{sub}}} \quad (48)$$

Re-arranging equation (46) and replacing n_{lot} with u_{lot} gives:

$$s_S^2 = \frac{s_1^2}{u_{\text{sub}} \cdot n_{\text{sub}}} \quad (49)$$

This expression for the sampling variance can be substituted into equation (47) to give a relationship for the overall variance from which the overall precision can be simply obtained in equation (50):

$$s_{\text{SPM}}^2 = \frac{\frac{s_1^2}{n_{\text{sub}}} + \left(1 - \frac{u_{\text{sub}}}{u_{\text{lot}}}\right) s_{\text{sub}}^2 + s_{\text{PM}}^2}{u_{\text{sub}}} \quad (50)$$

For continuous sampling, equation (50) simplifies to:

$$s_{\text{SPM}}^2 = \frac{\frac{s_{\text{I}}^2}{n_{\text{sub}}} + s_{\text{PM}}^2}{u_{\text{sub}}} \quad (51)$$

Re-arranging equation (50) gives an expression for the number of increments to be taken from each sub-lot sampled in order to achieve a desired overall precision. That is:

$$n_{\text{sub}} = \frac{s_{\text{I}}^2}{\left(u_{\text{sub}} \cdot s_{\text{SPM}}^2\right) - \left(1 - \frac{u_{\text{sub}}}{u_{\text{lot}}}\right) s_{\text{sub}}^2 - s_{\text{PM}}^2} \quad (52)$$

It is possible to simplify equation (52) in the case of continuous sampling to:

$$n_{\text{sub}} = \frac{s_{\text{I}}^2}{\left(u_{\text{lot}} \cdot s_{\text{SPM}}^2\right) - s_{\text{PM}}^2} \quad (53)$$

If the value of the number increments per sub-lot determined from equations (52) or (53) is impracticably large, increase the number of sub-lots to be actually sampled by one of the following means:

- choose a larger value for u_{sub} in equation (52) or for u_{lot} in equation (53), recalculate n_{sub} and continue this process until the value of n_{sub} is a practicable number;
- decide on the maximum practicable number of increments per sub-lot, n_{sub} , and, in the situation where intermittent sampling is used, calculate u_{sub} from the following equation:

$$u_{\text{sub}} = \frac{u_{\text{lot}} \left(\frac{s_{\text{I}}^2}{n_{\text{sub}}} + s_{\text{sub}}^2 + s_{\text{PM}}^2 \right)}{\left(u_{\text{lot}} \cdot s_{\text{SPM}}^2\right) + s_{\text{sub}}^2} \quad (54)$$

Adjust u_{sub} upwards, if necessary, to a convenient whole number and recalculate n_{sub} from equation (52).

In the situation where continuous sampling is used and where $u_{\text{sub}} = u_{\text{lot}}$, equation (54) simplifies to:

$$u_{\text{sub}} = \frac{\frac{s_{\text{I}}^2}{n_{\text{sub}}} + s_{\text{PM}}^2}{s_{\text{SPM}}^2} \quad (55)$$

Adjust u_{sub} upwards, if necessary, to a convenient whole number and recalculate n_{sub} from equation (53).

16.6 Methods of sampling from wagons and barges

16.6.1 General

The methods described in this clause are applicable to railway wagons, road wagons and shallow barges. A sub-lot can be one or any number of wagons, an entire barge, several barges or one hold of a barge. Calculate the number of sub-lots in the lot and the required number of increments in each sub-lot by the methods given in 16.5.

16.6.2 Extracting increments

For dry bulk material, take increments using a mechanical auger (16.9.2). For moist bulk material of nominal top size less than 10 mm, spear sampling may be used. Ensure that a full column of bulk material is extracted, so as to obtain a representative increment. Do not deliberately push aside large and hard pieces of the bulk material when collecting an increment. Do not allow wet material to adhere to the sampling equipment.

16.6.3 Distribution of increments

16.6.3.1 Distribution in wagons

If the number of increments required for a sub-lot is less than the number of wagons in the sub-lot, take one increment from each of that number of wagons. When the number of increments required for a sub-lot is greater than the number of wagons in the sub-lot, determine the number of increments taken from each wagon by dividing the total number of increments by the number of wagons; if after this division there is a remainder of increments, distribute these increments over the sub-lot.

The selection of wagons may either be systematic (e.g. every third wagon) or random (see 16.6.4).

Vary the positions of the increments from wagon to wagon so that all parts are correctly represented. There are various methods for doing this and different schemes may be preferred for use with different designs or sizes of wagons.

The surface of the bulk material in the wagon, for example, can be divided into numbered squares, each side about 1 m, the number of squares being dependent on the size of the wagon. If only a single increment is required from each wagon, systematic sampling can be used; for example taking increments from the numbered squares in rotation. In all other circumstances, use random selection (16.6.4).

16.6.3.2 Distribution in barges

Although barges or even their holds are generally larger than wagons, the method of distribution of increments is, in principle, the same. The procedures given in 16.6.3.2 may therefore be applied to barges and/or barge holds.

16.6.4 Random selection of increments

Identify all the possible sampling areas (wagons, barges, barge holds or parts thereof) and number them serially. Select the areas to be sampled by one of the following methods:

- a) Generate, by computer, a random number for each increment required from a set corresponding to the total identified.
- b) Provide a set of numbered discs, one disc corresponding to each sampling area and then proceed as follows.
 - 1) When selecting wagons, barges or holds, place the discs in a bag and draw sufficient disks from the bag to coincide with the total number to be sampled. Attach the selected discs to a reference board and sample those wagons, barges or holds corresponding to the numbers on the selected discs.
 - 2) When selecting sampling areas within containers (wagons, barges or barge holds), place the discs in a bag close to the sampling point and provide a diagram on a fixed board showing the locations of the areas across the surface of the bulk material. To sample the first selected container, draw sufficient discs from the bag to coincide with the total number of increments to be taken from that container and take an increment from those areas corresponding to the numbers on the selected discs. Place these discs in a second bag after use. For the second container, follow the same procedure by drawing discs from those remaining in the first bag. Continue this process for subsequent containers until all the discs are used up and then swap the bags over so that discs are drawn from the second bag and placed in the first bag. This procedure ensures that the order of the sampling areas from which increments are taken is always different.

16.6.5 Mass of primary increments

The mass of primary increments shall be greater or equal to the mass corresponding to the dimensions of a sampling implement designed to avoid bias and which therefore comply with the requirements of 7.4. Primary increments shall be of almost uniform mass; i.e. the coefficient of variation of the masses should not be greater than 20 %.

16.6.6 Duplicate sampling

Take twice the number of increments calculated in accordance with 16.5, distributed over the sub-lot, and place alternate increments into separate containers.

16.7 Sampling from holds of ships and large barges

Sampling from stationary bulk material in the holds of ships and large barges is not satisfactory for determining the quality of bulk material for commercial transactions because of the difficulty of obtaining a representative sample. Furthermore, such sampling may involve hazardous operations and the safety precautions necessary to render sampling reasonably safe are likely to lead to unacceptable delays during loading or unloading, as the case may be.

As a consequence of the impact of these disadvantages and because the bulk material handling equipment available for loading and unloading ocean-going and coastal ships as well as barges of typically coaster size will almost always provide facilities for sampling from a moving stream, sampling from the holds of such vessels is not treated by this part of ISO 11648.

However, the use of a mechanical auger for sampling from the holds of small barges is described in 16.9.2; i.e. those which have dimensions such that the conditions of sampling, especially to the full depth of the hold, are comparable to those prevailing when sampling from rail wagons.

In all other situations requiring mechanical sampling from ships, the only applicable method of sampling specified by this part of ISO 11648 is by using a mechanical cutter to sample from a moving stream while the bulk material is being loaded or off-loaded.

16.8 Sampling from stockpiles

16.8.1 General

Sampling bulk material from a stockpile presents difficulties in obtaining a representative sample and therefore is not a recommended procedure. The only really effective and recommended method for sampling bulk material in a stockpile is by sampling during the building up or the breaking down of the stockpile. A sample taken from the top or sides only of a stockpile cannot be regarded as being representative of the whole stockpile, particularly when the stockpile is composed of bulk material from more than one source.

In all cases, a sample can represent only that part and that depth of the bulk material from which it is collected. For example, if increments are taken by an auger that can penetrate to a depth of 2 m only, the results of tests on any sample can be regarded as being representative of the quality of bulk material in the stockpile down to that depth only. In effect, a 2 m thick shell has been sampled. Thus, where such an implement is used to sample a 20 m high stockpile, only the material contained in the top 2 m can be taken as the quantity of bulk ore for which the final result is possibly valid.

Some sampling implements may cause degradation of the bulk material and care should be taken to ensure that the properties of the material deemed critical are not affected by the sampling implement.

16.8.2 Selection of sampling points

Determine the number of sub-lots as follows. By survey, determine accurately the layout of the stockpile and draw a survey plan. On the plan, divide the stockpile into sub-lots containing approximately equal masses of accessible bulk material, and number each segment. Divide the stockpile into at least 20 sub-lots. The size of these sub-lots should be such that they are easy to locate on the stockpile.

16.8.3 Mass of primary increments

The mass of primary increments shall be greater or equal to the mass corresponding to the dimensions of a mechanical auger designed to avoid bias and which therefore comply with the requirements of 7.4. Ensure that a full column of bulk material is extracted, so that a representative increment is obtained, by using an auger that can penetrate to the bottom of the stockpile. Primary increments shall be of almost uniform mass; i.e. the coefficient of variation of the masses should not be greater than 20 %.

16.9 Equipment for stationary sampling

16.9.1 General

In practice, spears and mechanical augers are used where the primary increments are to be collected from the body of a stockpile or from a wagon, but they may produce a biased sample because the whole of the lot is not equally accessible. The samples obtained will at best be representative of the depth of bulk material to which the implement penetrates. The use of an auger can also cause particle breakage and therefore affect size distribution and bulk density of the bulk material sample. Therefore, sampling with augers and spears is not recommended unless the full column of bulk material can be extracted. The procedures below minimize some of the errors.

16.9.2 Mechanical auger

The mechanical auger consists of a cylindrical steel tube containing an Archimedean screw (see Figure D.2) which is mounted on a structure in such a way that it can take a vertical core from the full depth of bulk material. The pitch of the screw and the annular gap (the distance between the shaft and the tube) shall each be at least three times the nominal top size of the bulk material.

Where sampling using augers is unavoidable, increments may be taken from bulk material with a nominal top size of less than 25 mm, provided that care is taken to ensure that the full column of bulk material is taken out and that no particles are lost when the auger is being extracted.

It is essential that the diameter of the auger be at least three times the nominal top size of the bulk material or 30 mm, whichever is the greater. When sampling bulk material with a nominal top size greater than 25 mm, auger sampling may be found to be impossible unless mechanical apparatus is used. Where mechanical apparatus is used, the amount of material taken will usually exceed that required.

16.9.3 Spears

Spear sampling may be used to sample moist bulk material of nominal top size less than 10 mm, provided that care is taken to ensure that the full column of bulk material is taken and that no particles are lost when the spear is being extracted. The internal diameter of the spear (see Figure D.3) should be at least three times the nominal top size of the bulk material or 30 mm, whichever is the greater. Spear sampling is not suitable for dry bulk material.

16.9.4 Sampling procedure using augers and spears

The procedure for sampling using an auger or spear is as follows:

- a) take increments from positions spaced as evenly as possible over the surface of the bulk material to be sampled;
- b) ensure that wet bulk material is not allowed to adhere to the outside of the implement when it is withdrawn, and that wet bulk material is not left adhering to the inside of the implement when extracting the increment;
- c) place the increments into labelled containers as specified in clause 23.

17 Principles of sample preparation

17.1 General

Sample preparation involves several distinct operations, which are sometimes preceded by drying. These are as follows:

- a) reduction, i.e. to decrease the particle size by crushing, grinding, or pulverization;
- b) mixing;
- c) division, i.e. to decrease the sample mass by dividing the sample into two or more parts.

These operations are generally considered to constitute one stage of sample preparation.

As a general rule, reduction should always precede division. An exception occurs where high capacity streams are being sampled mechanically; it is then permissible to divide large primary increments, as specified in clause 10.

The stages of sample preparation should be chosen to minimize errors during sample preparation without having to retain too large a mass.

NOTE 1 Examples of sample preparation schemes are given in annex E.

NOTE 2 All surfaces over which the sample passes should be constructed of abrasion-resistant material which will not be eroded in such a way as to contaminate the sample.

17.2 Minimum mass of sample to be retained after division

The procedure for sample preparation should involve two or more stages. The amount of sample to be retained at a given stage depends upon the nominal top size of the bulk material at that stage, and will be in accordance with the minimum mass of the gross sample, as determined by the method given in 9.2.

17.3 Drying

For samples other than those used for moisture determination, the sample may be air-dried or oven-dried. The method for treatment of moisture samples is specified in clause 20.

If the sample is wet or sticky, preliminary drying is often the first operation carried out in the first sample preparation stage. In this situation, preliminary drying (also called pre-drying) is necessary so that the sample will pass through the reduction and sample division equipment freely and without loss or contamination.

Drying may be carried out at any stage of sample preparation; e.g. drying prior to pulverization. Drying is continued until the sample is visibly dry.

For some materials, it is necessary to dry at ambient temperature to avoid changes in the quality characteristic.

Materials that are susceptible to oxidation should be dried in an inert atmosphere, not at an excessive temperature. No sample should be exposed to a temperature exceeding 105 °C.

The following methods may be used for air-drying a sample to ensure that it will pass through mills and sample dividing equipment freely and without significant loss or contamination.

- a) **Air-drying oven:** Pass heated air, not exceeding 40 °C, over the sample in an air-drying oven. Ensure the oven is able to make a complete change of air at least three times per hour, but at an air velocity which will not dislodge the sample from its tray.

ISO 11648-2:2001(E)

Place the sample in the oven on corrosion-resistant trays and spread it evenly in a layer of uniform thickness to a depth not exceeding the greater of:

- 1) twice the nominal top size of the bulk material;
 - 2) 20 mm, except for lumps greater than this size.
- b) **Drying floor:** Ensure that the drying floor is a smooth, clean surface, protected from direct sunshine, rain and excessive breeze.

Spread the bulk material uniformly to a depth not exceeding twice its nominal top size. To aid drying, stir or rake the bulk material periodically, without loss of material.

17.4 Reduction of particle size

17.4.1 General

Crushing, grinding or pulverizing apparatus, referred to as “mills” in this part of ISO 11648, are used to reduce the nominal top size of the bulk material to a suitable level for subsequent division.

The purpose for which the sample is to be used will determine whether it is permissible to reduce the particle size during sample preparation. The several cases considered are as follows.

- a) **Chemical analysis sample:** The bulk material will invariably require size reduction to meet the specifications of 21.2.2. The sample may be reduced as appropriate to facilitate the operations of division described in 17.6.

It is permissible, when handling samples intended for chemical analysis, to dry the material as received so that handling characteristics are improved. When drying is used, observe the following precautions.

- 1) Avoid any contamination, oxidation or physical loss.
 - 2) Do not heat the sample to a temperature at which combined water or any other volatile component can be lost. Do not exceed a maximum temperature of 105 °C for any portion of the sample.
- b) **Moisture sample:** Do not submit bulk material having a nominal top particle size of less than 10 mm to size reduction prior to moisture determination.

When handling bulk material with a nominal top size of greater than 10 mm, and which is not adhesive or excessively wet, the bulk material may be reduced in particle size to less than 10 mm, care being taken to minimize any change in moisture level.

When handling bulk material with a nominal top size of greater than 10 mm, and which is adhesive or excessively wet, the total sample may be weighed and air-dried. When it has dried to a free-flowing state, re-weigh the sample. The sample may then be reduced in particle size prior to division and determination of residual moisture.

When this procedure is followed, the final moisture value will take into account the moisture lost in the air-drying stage.

- c) **Physical testing sample:** Do not submit the sample to size reduction when samples are to be used for:
- 1) determination of particle size distribution; or
 - 2) determination of bulk density.

Feed the sample uniformly into mills in such a way as to avoid choking of the mill or changes in mill speed, which can result in variation in the size distribution of the product.

Errors of sample division and analysis are increased by the presence of oversize material. Therefore regularly check mill performance so as to ensure that the mill product meets the required nominal top size.

During preparation of the chemical analysis sample, do not use screening to remove oversize particles for recrushing. Material which is difficult to crush is usually different in composition from the remainder of the sample and cannot be satisfactorily mixed back into the sample.

17.4.2 Mills

Particle size reduction mills that may be used for particulate material samples include jaw crushers, roll crushers, plate mills, hammer mills (impact pulverizers) and ring mills, the latter generally being preferred for the final stages of grinding to the required nominal top size. Examples of particle-size reduction equipment are given in annex F.

Factors which influence the choice of mill for any stage of sample preparation are the type of crushing action of the mill and the requirements of the particular testing procedure.

Mills that crush mainly by impact (e.g. hammer mills) or mainly by compression (e.g. jaw crushers and roll crushers) are preferred to those that grind by attrition under pressure (e.g. plate mills).

In the first stage of sample preparation, it may be necessary to break large lumps of material manually to suit the feed size of the mill.

Those parts of the apparatus that come into contact with the sample should be made of wear-resistant material, to minimize contamination. This is particularly important with samples in which trace elements are to be determined, every effort being made to use equipment which does not contain any of those elements.

Certain particle-size-reduction apparatus, such as high speed impact pulverizers, ring mills and plate mills, become heated, so avoid keeping samples in them long enough to become affected. If a mill is used for a series of samples, cool it between each operation.

High-speed impact pulverizers may be seriously damaged by the presence of hard extraneous material in the sample, so prevent such material from entering the mill. A magnetic separator may be placed on the chute leading to the machine to safeguard against the entry of certain ferrous materials, provided that the bulk material is not susceptible to magnetism.

Although high-speed pulverizers are the most efficient for a wide range of materials, they generate dust owing to the fan-like effect of the rotating hammers. To avoid loss of fine material, limit the volume of fresh air passing through the mill (for example by using closed inlet or outlet hoppers with or without an air recycle tube, or by fitting a breather bag to the mill outlet).

Make sure all mills are easy to clean and are cleaned between each sample.

17.5 Sample mixing

17.5.1 General

Errors in sample division can be reduced by thoroughly mixing the sample prior to division. The need for mixing is particularly important where samples from more than one source are combined. Some methods of mixing, for example forming and reforming into a conical pile, or some rotary methods of mixing, may have the opposite effect to that intended, leading to increased segregation. Consequently, the choice of the most appropriate method of mixing is critical, and depends on the nature of the bulk material.

Except where a moisture sample is to be taken, dry samples that are not free-flowing at a temperature not exceeding 105 °C before mixing.

Where samples are taken for moisture determination, carry out the mixing as quickly as possible to minimize changes in moisture content.

17.5.2 Methods of mixing

Mixing can be carried out using any of the following methods.

- a) **Passing the sample through a riffle or rotary sample divider:** Pass the sample through a riffle or rotary sample divider at least three times in succession, and recombine the sample after each pass.
- b) **Use of strip mixing:** The sample material is formed into a strip by careful distribution of the bulk material from a shovel. The length-to-width ratio of the strip shall be no less than 10:1. Take a complete cross-section of the ore strip randomly and spread it out to form a new strip. Take successive cross-sections randomly and spread them out on top of the preceding cross-section, layer upon layer, until the old strip has been converted into a new strip. Repeat the process of taking cross-sections and reforming a new strip twice.
- c) **Use of a mechanical mixer:** See examples in annex G.

17.6 Division

17.6.1 General

Sample division may be carried out by a variety of mechanical or manual methods. In all cases, collect the divided samples by taking and combining a large number of small increments. The minimum number of increments is 20.

Sample division may be carried out in as many passes as are needed so as to obtain the required divided sample mass; for example, when using a riffle, three passes are required to obtain a one-eighth fraction.

Material that is visibly wet may not flow freely, or may adhere to contact surfaces. In such circumstances, dry the sample as described in 17.3 before proceeding to sample division.

Examples of sample division apparatus are illustrated in annex H. Where division is performed for the purpose of extracting moisture samples, the preferred methods are mechanical division (see 17.6.2) or increment division [see 17.6.3 a)].

17.6.2 Mechanical sample division

The main advantage of mechanical sample division is that the divided sample is obtained by taking a much larger number of increments than is generally obtainable manually. The minimum number of increments is 20.

The design criteria for acceptable mechanical sample dividers follow the same general design principles as for mechanical sample cutters (see clause 13). Although cross-stream cutters are used, rotary dividers are more common in sample preparation.

Examples of acceptable mechanical rotary sample dividers are as follows.

- **Rotating cone (Figure H.1):** The machine consists of a feed hopper, a low-speed slotted rotating cone, a reject chute and a sample pipe. Bulk material is allowed to flow from the feed hopper onto the rotating cone which diverts it into the reject chute. The slot in the cone allows the bulk material to fall directly into the sample pipe for part of each revolution.
- **Rotary sample divider (Figure H.2):** The machine comprises a number of sector-shaped canisters positioned on a platform, and a feeding device. The uniform bulk material stream flows to the hopper spout and, by relative rotation of these two components, the flow is intercepted by the top edge of the sector-shaped canisters, dividing the sample into representative parts.
- **Rotating chute (Figure H.3):** A hollow shaft, to which is attached one or more cutters, rotates in an offset cone-shaped housing. A feed pipe is positioned above the rotating cutter. As bulk material falls through the feed pipe, the cutter intersects the stream and diverts an increment through the hollow shaft.

The procedure for dividing by rotary division is as follows.

- a) Place the sample into the hopper of the rotary divider, ensuring that the opening at the bottom of the hopper is large enough to prevent bridging.
- b) Ensure that the opening of the segment or cutter lips at any point where it intersects the bulk material stream is a minimum of three times the nominal top size of the material.
- c) Ensure that the speed of the divider at any point where it intersects the bulk material stream is constant and $\leq 0,6$ m/s.
- d) Activate the cutter prior to commencing the feed of the bulk material.
- e) Allow a minimum of 20 passes of the receiving segment or cutter during the bulk material feed.
- f) Continue rotation of the cutter until the bulk material feed has been completed.

Other types of mechanical sample dividers may be used, provided that they conform to the requirements of this part of ISO 11648, and do not introduce bias.

17.6.3 Manual sample division

Sample division may be carried out manually using one of the following procedures.

- a) **Increment division**, is carried out as follows.
 - 1) Mix the bulk material thoroughly and spread on a flat plate in the form of a rectangle of uniform thickness, as given in Table 5.

Table 5 — Cutter having cutter lips normal to the cutter path

Nominal top size mm	Minimum mass of increment kg	Thickness of flattened sample mm
$\leq 11,2$	Masses need to be determined; refer to clause 9.	30 to 35
16,0		40 to 50
22,4		55 to 65
31,5		80 to 90
45,0		110 to 120

- 2) Mark a matrix on the spread sample (see Figure 7) with a minimum of 20 parts.

The matrix should be designed in conjunction with Table 5 to give the total amount of sample required for subsequent analysis. The ratio of the length to the width should never be more than 5:4.

- 3) Collect one increment of mass given in Table 5 from each part of the matrix with an appropriate flat-bottomed scoop chosen from the series shown in annex I.
- 4) Insert a flat bump plate vertically through the spread material until it comes into contact with the mixing plate. Then insert the scoop to the bottom of the spread material and take the increment by moving the scoop horizontally until its open end comes into contact with the bump plate, ensuring that all particles of the material are collected off the top of the mixing plate.
- 5) Lift the scoop and bump plate together so that material is prevented from falling from the open end of the scoop by the bump plate.

- 6) If the mass of the combined increments is less than that determined in accordance with 17.2, collect further complete sets of increments, as stated in 3), until the minimum mass is exceeded.

NOTE This method is regarded as a high-precision method in spite of the large division ratio; i.e. the ratio of the total sample mass to the retained sample mass. It is a recommended manual method for obtaining moisture samples.

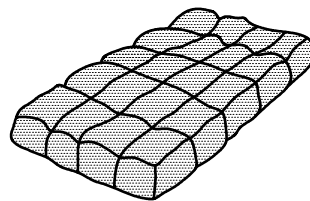
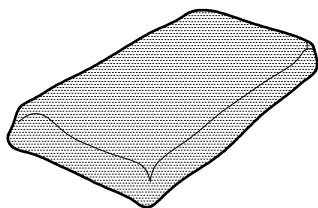

a) Spread the crushed gross sample into a rectangle with a thickness as specified in Table 5.

b) Arrange in 20 equal parts, e.g. into 5 equal parts lengthwise and 4 equal parts breadthwise.

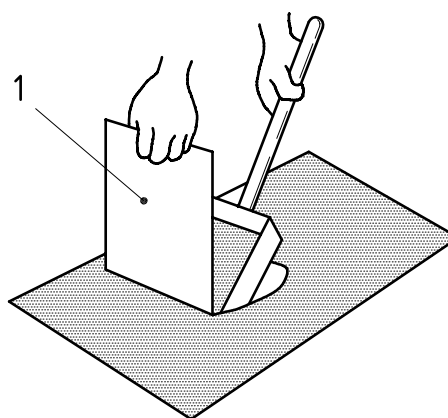
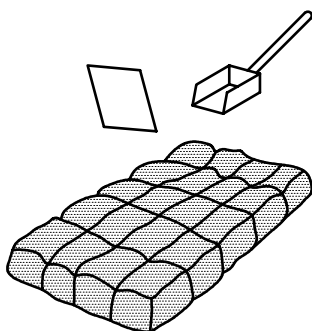

c) Take a scoopful of sample at random from each of the 20 parts by inserting the scoop to the bottom of the sample layer and combine the 20 scoopfuls of sample into a divided sample.

d) Outline of taking an increment by using a bump plate shown in c).

Key

1 Bump plate

NOTE Example for arranging into 20 parts.

Figure 7 — Manual increment division

- b) **Riffling:** A riffle is a sample divider which is used to divide the bulk material fed onto it into halves, one being retained and the other rejected. It operates by allowing the material to fall through a set of parallel slots of uniform width, adjacent slots feeding opposite containers.

A riffle is symmetrical (so that a part-sample may be taken from either side) and all surfaces on which bulk material may rest should be inclined at no more than 30° to the vertical. Fit receivers closely against the body of the riffle, to minimize loss of dust. It is essential that the riffle used is appropriate to the nominal top size of the material to be divided, as serious errors may be introduced if the slots are too small or if there are too few slots.

The slot width shall be at least twice the nominal top size of the bulk material. There shall be at least eight slots for each half of the riffle.

Carry out the riffling as follows.

- 1) Mix the material and place it in a feed container.
- 2) Spread the material in the feed container so as to spread it along the full length of the container.
- 3) Tip the container to feed the material uniformly into the feed chute, so as to pass the material through the riffle and collect it in two canisters.

If the material chokes the riffle, clear it before the operation is continued. In this case, air-drying may be necessary.

- 4) Retain the sample from one of the receiving canisters, chosen at random.

If further subdivision is required, the retained sample may be passed through the riffle again. For successive passes, the retained sample should be taken from alternate sides.

Take care to minimize loss of moisture from a sample when carrying out division using a riffle. Use closed riffles for dividing moisture samples, or for dry bulk material to prevent loss of dust. Use gated riffles when dividing small sample masses. Examples of riffles are given in annex J.

- c) **Strip mixing and splitting:** Strip mixing and splitting simulates the sampling of bulk material from a conveyor belt. Carry out strip mixing and splitting as follows.

- 1) Form the material from a pile into a strip by careful distribution of the material from a shovel along the length of the strip as evenly as possible, working from end to end of the strip and from both sides of the strip. The length-to-width ratio of the strip shall be no less than 10:1. The general appearance of a completed strip is given in Figure 8. The end plates ensure that size segregation only occurs laterally.
- 2) Take the subsample by inserting a suitable sampling frame across the strip and removing the material from between the frame using a scoop (Figure I.1), ensuring that all fine particles are included in the increment. Take the number of increments required (minimum 20).

This procedure is not recommended for obtaining a moisture sample.

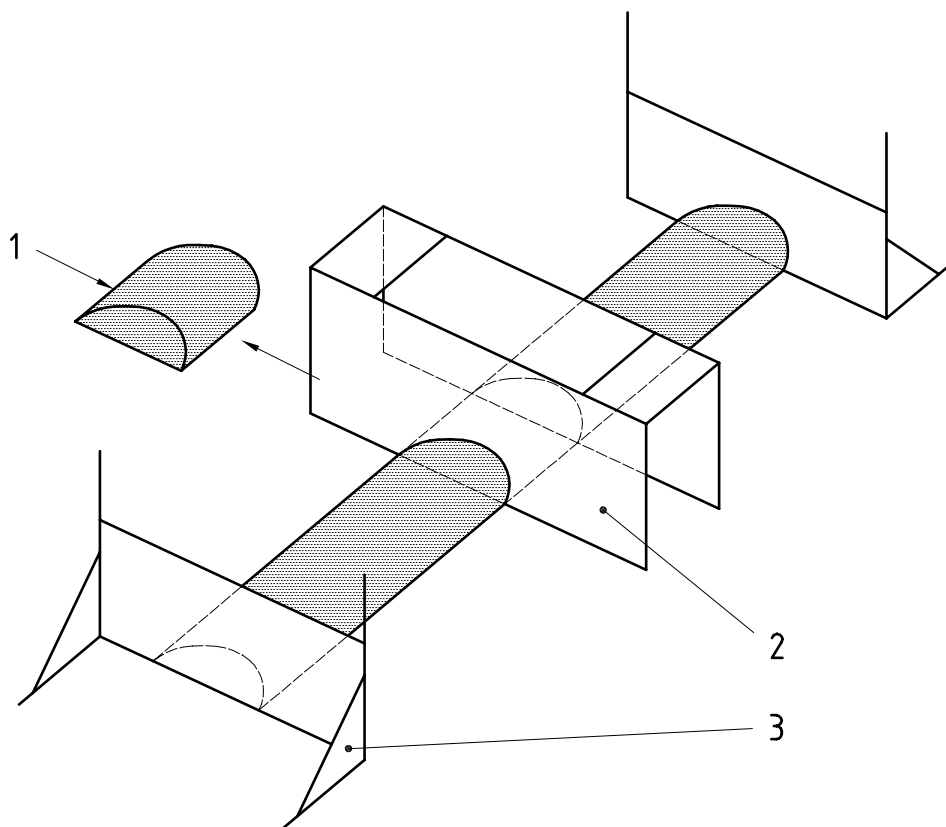

Key

- 1 Increment
- 2 Sampling frame
- 3 End-plates ("book-ends")

Figure 8 — Completed strip

d) **Fractional shovelling** (see Figure 9): The procedure for division by fractional shovelling is as follows.

- 1) Mix the material and form a heap on a smooth clean surface.
- 2) Using an appropriate shovel, as described in Figure I.2, take successive shovelfuls from the base of the heap, working around the base.
- 3) Place each successive shovelful on separate successive heaps, the number of heaps being determined by the division ratio. For example, if a 1 in 5 division ratio is required, five heaps, N_1 to N_5 are formed as shown in Figure 9. Ensure that at least 20 shovelfuls are placed on each heap.
- 4) Select at random the heap to be retained.

This division process may be used for bulk material having a nominal top size up to 45 mm.

This method is not recommended for obtaining a moisture sample.

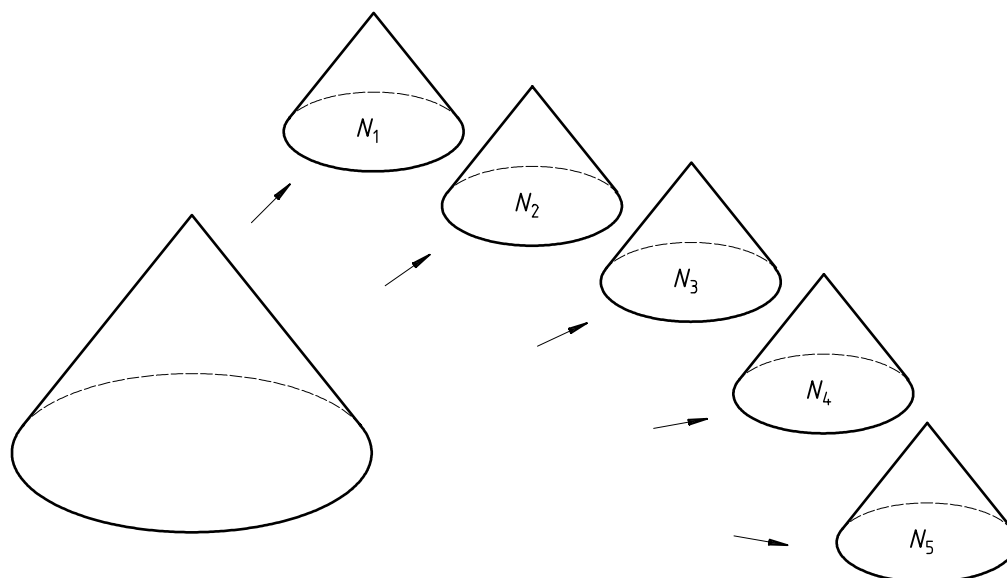

Figure 9 — Sampling by fractional shovelling

18 Precision of sample preparation

Check the precision of sample preparation periodically and whenever a new scheme is brought into operation. Test procedures for the determination of precision in sample preparation are given in ISO 3085 and ISO 13909-7 and these procedures may be applied to other bulk materials.

19 Bias in sample preparation

19.1 General

Check the bias in sample preparation periodically and whenever a new scheme is brought into operation. Procedures for checking bias in sample preparation are given in ISO 3086 and ISO 13909-8 and these procedures may be applied to other bulk materials.

Contamination is often a major source of bias during sample preparation. Contamination may be attributable to preparation equipment or cross-contamination.

19.2 Contamination from preparation equipment

Potential causes of contamination from preparation equipment include the following.

- a) **sieves:**
 - 1) **brass sieves:** copper, lead, tin;
 - 2) **stainless-steel sieves:** silver, lead (silver solder sometimes used).
- b) **Jaw crusher:** iron, manganese.
- c) **Roll mill:** iron, manganese.

- d) **Ring grinder:**
- 1) **tungsten carbide:** cobalt, titanium, tungsten, carbon;
 - 2) **chrome steel:** chromium, iron;
 - 3) **Colmony:** chromium, nickel.
- e) **Plate grinders:** iron, cobalt, chromium, copper, molybdenum, manganese, nickel, vanadium.
- f) **Hammer mills:** manganese, iron, carbon.

For items b) to f) inclusive, the amount of contamination of a sample will increase with the hardness of the particulate material; for item d) or e), contamination will increase with grinding time. Irregular particles are also more abrasive.

19.3 Cross-contamination

Potential causes of cross-contamination include the following.

- a) **Dust:** Dust settling on open samples can be a possible cause of contamination. Minimize dust settling by ensuring as much work as possible is carried out using a dust extraction system. (Silicate dusts are a health hazard.) If possible, dust escaping from heavy equipment such as jaw crushers, roll mills and plate grinders should be extracted downwards and to the rear. Keep all ducting, machinery and floors clean.
- b) **Sample:** This is most notable when an anomalous sample is prepared followed by a background sample and is commonly used by geologists to check a laboratory's procedures. To prevent cross-contamination, clean all equipment used between samples as follows, ensuring that the sample has been removed first.
- 1) **Jaw crushers:** Use compressed air between samples. Ensure that no material is lodged between the plates or above them. Clean the tray between the samples also with air.
 - 2) **Roll mill:** Clean the roll mill only after turning it off, isolating the machine from power, removing protective covers to fully exposing rolls and disconnecting rolls from drive. Do not allow the rolls on this machine to become too pitted or worn in the centre. When either of these two conditions occurs, machine the rolls.
 - 3) **Plate grinder:** For flushing out the grinder, use material similar to that being ground in the sample preparation, then clean it with compressed air.
 - 4) **Hammer mill:** Use compressed air. Open the door and clear inside of the door as well. Check the screen for wear.
 - 5) **Ring grinder:** For flushing out the grinder, use material similar to that being ground in the sample preparation, and then clean it using either air or a damp cloth.
- c) **Sieving:** Where samples require sieving for geochemical work, use only nylon sieves unless they are not available for a particular size. Inform the client of possible contamination problems if this is the case.
- d) **Mercury:** Loss of mercury can be caused by drying at greater than 50 °C as well as pulverizing for too long a period. Prevent ring grinding bowls from getting too hot when working with large numbers of samples.

20 Preparation of samples for the determination of moisture

20.1 Samples to be tested

20.1.1 Type

The sample to be tested shall be either:

- a) a sample collected exclusively for the determination of moisture; or
- b) a sample on which determinations of moisture and other quality characteristics are required.

20.1.2 Mass

The mass of each moisture sample shall not be less than 1 kg. Recommended masses of samples at various nominal top sizes are given in Table 6. Samples of nominal top size greater than 22,4 mm may be subjected to a two-stage drying procedure, as described in 17.4.1 b).

Table 6 — Example of recommended minimum mass of sample for the determination of moisture in ores

Nominal top size of ore	Maximum layer thickness	Minimum mass	Maximum allowable difference between subsequent weighings of dried samples	Accuracy of weighing	Minimum drying time
mm	mm	kg	g	g	h
63,0	70	110	110	10	16
45,0	50	40	40	4	12
31,5	35	14	14	1	8
22,4	25	5	5	0,5	6
16,0	20	2	2	0,2	4
11,2	13	1	1	0,1	4

20.2 Precautions against loss of moisture

One of the main difficulties in determining moisture is that of minimizing changes in the moisture content of the sample when preparing the moisture sample. Take every precaution to minimize changes in moisture content due to unsuitable containers and by evaporation during handling, particularly if the bulk material is extremely wet. Keep all moisture samples in sealed containers in a cool place and out of direct sunlight before and after preparation as well as during any interval between stages of sample preparation.

Take care to minimize changes in moisture content during particle size reduction, by using equipment in which there is no appreciable heating, and by reducing the amount of air passing through the mill to a minimum.

Take care to minimize changes in moisture content when carrying out sample division; carry out such operations as quickly as possible. In some circumstances, it may be necessary to carry out moisture determinations on each increment, to minimize moisture changes (see annex E).

Where moisture samples are to be retained for any length of time; for example for more than five to seven days in the case of umpire and shipping samples, place them into moisture-impervious plastic bags which are sealed so as to minimize free air space. Then store them in an airtight container.

20.3 Samples for determination of moisture

Moisture in bulk material may be determined by heating a sample of material at 105 °C in air until constant mass is achieved.

Preparation of the sample may include preliminary air-drying (see 17.3) if the material is visibly wet.

20.4 Sample preparation procedure

20.4.1 General

A standard procedure is specified for preparation of samples for determination of moisture, either from the common sample or from the moisture sample. This standard procedure is shown schematically in Figure E.1.

20.4.2 Air-drying methods

20.4.2.1 Air-drying the moisture sample

The procedure is as follows.

- a) Weigh the container and material test portion before opening the container (as received) (m_1).
- b) Weigh a clean, dry drying tray (m_2).
- c) Transfer the material to the drying tray and spread evenly to a depth not exceeding those given in Table 6, except for lumps greater than this depth.
- d) Air-dry the drying tray plus material together with the container and lid (if any) plus any adhering particles of material (see 17.3), until the change in mass is less than 0,1 % of the initial mass of the test portion (see Table 6).
- e) When the masses of consecutive weighings agree within 0,1 % of the mass of the test portion, record the mass of the dry container plus lid plus drying tray plus dried material, m_3 .
- f) Brush out any material adhering to the container and weigh the dry container plus lid to the nearest gram, m_4 .
- g) Calculate the percentage loss of moisture on air-drying, w_m , from the following equation:

$$w_m = \frac{m_1 + m_2 - m_3}{m_1 - m_4} \times 100 \quad (56)$$

where

- w_m is the air-dried moisture content, expressed in percent, of the test portion;
- m_1 is the total mass, expressed in kilograms (four decimal places), of the container, its lid and the test portion;
- m_2 is the mass, expressed in kilograms (four decimal places), of the drying tray;
- m_3 is the total mass, expressed in kilograms (four decimal places), of the dry container, its lid, the drying tray and the dried test portion;
- m_4 is the mass, expressed in kilograms (four decimal places), of the dry, empty container;

Further treatment of the air-dried material is described in 20.4.3.

20.4.2.2 Extraction and air-drying of the moisture sample from a common sample

Carry out the following procedure.

- a) Tip all of the sample onto a clean, steel plate and arrange the sample to form a rectangle.
- b) Extract a minimum of 20 increments by increment division (see Figure 7), the mass of individual increments depending on nominal top size of material. As an example, recommended minimum masses for a range of nominal ore top sizes are shown in Table 6. Similar tables need to be developed from duplicate determinations for bulk materials other than mineral ores.
- c) Repeat the process of extracting increments if reserve samples are required.
- d) Use the residue of the common sample remaining after extraction of the moisture samples for preparation of a general analysis sample.
- e) Air-dry the moisture sample using the procedure given in 20.4.2.1 immediately after its extraction from the common sample.

20.4.3 Particle size reduction and division of the air-dried sample

Reduce the air-dried sample of bulk material without delay to a nominal top size of 22,4 mm, avoiding production of excess fines. Divide the crushed sample, preferably by using suitable mechanical equipment, to a mass of approximately 5 kg. If mechanical sample division apparatus is not available, increment division or riffing may be used.

Place one of the divided moisture samples in a sealed container, which is labelled with details of the sample and of the percentage of moisture lost by air-drying.

21 Preparation of samples for chemical analysis

21.1 General

The procedure for preparation of the chemical analysis sample is described in 21.2 and shown schematically in annex E. The moisture sample may be used as the chemical analysis sample after drying, provided it is sufficiently representative.

21.2 Procedure

21.2.1 First stage in the preparation

If necessary, the sample may be dried in accordance with 17.3. Pass the whole sample through the mill (see 17.4), mix it, then divide it (see 17.6) to decrease the mass to the value appropriate to the nominal top size of the crushed bulk material (see 17.2).

21.2.2 Further stages in the preparation

In the further stages of preparation, reduce the particle size of the portion retained from the first stage to the required nominal top size for analysis (see 17.4), then divide it to obtain as many samples as contractually required, each having a recommended mass of no less than 50 g.

Then place the chemical analysis sample in a sealed container and label it with all necessary identification details.

22 Preparation of samples for physical testing

22.1 General

The procedure for preparation of samples for physical testing to measure particle size distribution or bulk density is described in 22.2. The moisture sample may be used for the determination of particle distribution or for determination of the bulk density of oven-dried material after drying, provided it is sufficiently representative.

Where it is necessary to determine the bulk density of as-received material, collect a sample exclusively for this purpose, taking account of precautions given in 20.2. If the determination of the bulk density of air-dried material is required, also collect a sample exclusively for this purpose, but no precautions to guard against loss of moisture by evaporation are necessary.

Do not submit the sample to particle size reduction during any stage of preparation in which particle size distribution or bulk density is to be determined.

Table 6 gives example values for minimum masses of mineral ore samples which can be used for physical testing of ores. However, they should only be regarded as indicative for other materials and therefore should only be used with caution.

22.2 Procedure

22.2.1 Preparation of sample for particle size distribution of ores

Consideration should be given to the characteristics of the ore when deciding the appropriate procedure for preparation of samples to be used for particle size distribution. Two types of ore are recognized as follows.

- a) **Type A:** In this type, the ore contains a fine fraction high in clay minerals which consolidate on drying. Consolidation of this type of fraction may render it very difficult to obtain a true determination of particle size distribution of the fine portion of the ore, even when the ore is rewetted in an effort to redisperse the fines.

When dealing with Type A ore, the samples taken in accordance with this part of ISO 11648 are protected from moisture evaporation in a manner similar to that described in 20.2. Wet screening is used for this type of ore;

- b) **Type B:** Type B does not contain any fine fractions high in clay minerals. Type B ores may be dried by exposure to the atmosphere or by the use of an oven. When testing type B material for the determination of particle size distribution, the sample previously used for determination of moisture can be used.

22.2.2 Preparation of sample for bulk density determination

Three cases where bulk density determination may be required are as follows:

- a) material as-received at natural moisture content;
- b) air-dried material;
- c) oven-dried material.

When the determination is to be made on as-received material [case a)], the sample is given the same protection as the moisture sample described in 20.2. For cases b) and c), such protection is unnecessary and, where appropriate, the sample used for determination of moisture content may be used for the determination of bulk density. Multiple use of samples for physical tests is not recommended because of the potential for contamination and degradation.

23 Precision and bias of measurement

Precision and bias at the measurement stage are to be assessed in accordance with ISO 5725 (Parts 1, 2, 3, 4, and 6) and with the *Guide to the expression of uncertainty in measurement*.

24 Packing and marking of samples

The samples for distribution shall be tightly sealed in air-tight containers. The label, and a card placed in the container, shall contain the following particulars:

- a) the type of bulk material and the name of the lot (e.g. name of ship, train);
- b) the mass of the lot and/or the sampling unit;
- c) the sample number;
- d) the place and the date of sampling;
- e) the moisture content of the lot and/or the sampling unit (if known);
- f) the place and the date of sample preparation;
- g) the particle size of the sample;
- h) any other consideration (if necessary), for example the special purpose of the test for which the sample is taken, such as the bias test or the particle size analysis.

Annexe A (informative)

Examples of variance calculations

A.1 General

This annex contains examples of variographic experiments which were conducted to determine the minimum number of cuts for division and their minimum masses.

A.2 Calculation of a sample variogram

The data in Table A.1 are the percentages of iron in samples of ore taken by stratified systematic sampling on a mass-basis at 2 800 tonne intervals during loading of a $40 \times 2\,800 (= 112\,000)$ tonne lot of iron ore. These data are plotted in Figure A.1.

Table A.1 — Percentage of iron in samples of iron ore

Sample	Fe %	Sample	Fe %	Sample	Fe %	Sample	Fe %
1	65,01	11	65,58	21	65,29	31	65,29
2	64,71	12	66,08	22	64,97	32	65,17
3	65,47	13	65,46	23	64,65	33	65,02
4	65,51	14	65,03	24	65,20	34	65,12
5	65,45	15	64,18	25	64,89	35	64,80
6	65,03	16	64,58	26	65,11	36	65,16
7	65,32	17	65,24	27	65,14	37	65,19
8	64,91	18	65,08	28	64,92	38	65,11
9	65,78	19	65,29	29	64,90	39	64,94
10	65,61	20	65,16	30	65,23	40	65,26

The sample variogram is calculated from these values using equation (5). For example, since there are 39 terms in the sum, corresponding to the 39 pairs of samples separated by 2 800 tonnes, the variogram value when lag t is Δm ($\Delta m = 2\,800$ tonnes) is:

$$\begin{aligned}
 V_{\text{exp}}(\Delta m) &= \frac{\sum_{i=1}^{39} (x_{i+1} - x_i)^2}{(2 \times 39)} \\
 &= [(64,71 - 65,01)^2 + (65,47 - 64,71)^2 + (65,51 - 65,47)^2 + \dots + (65,26 - 64,94)^2] / (2 \times 39) \\
 &= 0,068\,6
 \end{aligned}$$

Similarly, since there are 38 pairs of samples when the lag t is $2\Delta m$ (5 600 tonnes), the variogram value is :

$$V_{\text{exp}}(2\Delta m) = \frac{\sum_{i=1}^{38} (x_{i+2} - x_i)^2}{(2 \times 38)}$$

$$= [(65,47 - 65,01)^2 + (65,51 - 64,71)^2 + (65,45 - 65,47)^2 + \dots + (65,26 - 65,11)^2] / (2 \times 38)$$

$$= 0,102 1$$

The variogram values for lags $3\Delta m$, $4\Delta m$, ..., $n\Delta m$ can be calculated similarly. The values for the first 10 increment lags are given in Table A.2.

Table A.2 — Sample variogram values

Lag increments	$k =$	1	2	3	4	5
Lag (tonnes)	$k\Delta m =$	2 800	5 600	8 400	11 200	14 000
Variogram value	$V_{\text{exp}} =$	0,068 6	0,102 1	0,133 4	0,141 5	0,131 2
Lag increments	$k =$	6	7	8	9	10
Lag (tonnes)	$k\Delta m =$	16 800	19 600	22 400	25 200	28 000
Variogram value	$V_{\text{exp}} =$	0,124 3	0,098 2	0,102 5	0,112 2	0,132 5

A.3 Calculating a fitted linear variogram

The variogram values calculated in the above example are plotted in Figure A.2. To make use of these values to determine the sampling error, it is necessary to fit a straight line to these points. The line should be fitted only to the first few values of the variogram, the number of points being chosen to ensure that the points used lie close to a straight line. In this case, the first four points are close to a straight line, so lags up to four are used for fitting the line using standard linear regression as shown in Figure A.2.

The values of the intercept A_{exp} (the value of the fitted line at a lag of zero) and the slope B (the increase in the fitted line per unit increase in the lag) are as follows:

$$A_{\text{exp}} = 0,049 0$$

$$B = 8,92 \times 10^{-6} \text{ tonnes}^{-1}$$

A.4 Calculation of sampling variance for a single stage given a fitted variogram

A total of 70 samples has been taken from a lot of 35 000 tonnes of copper concentrate using systematic mass-basis sampling with a separation of 500 tonnes between samples. The sample values are given in Table A.3.

Table A.3 — Percentage of copper in samples of copper concentrate

Sample	Cu %	Sample	Cu %	Sample	Cu %	Sample	Cu %	Sample	Cu %
1	30,3	15	30,3	29	30,1	43	30,3	57	30,3
2	30,3	16	30,3	30	30,2	44	30,3	58	30,3
3	30,5	17	30,4	31	30,2	45	29,9	59	29,9
4	30,5	18	30,5	32	30,0	46	30,1	60	30,1
5	30,2	19	30,3	33	30,2	47	29,9	61	29,8
6	30,2	20	30,3	34	29,8	48	30,1	62	30,7
7	30,3	21	30,4	35	29,8	49	30,2	63	31,0
8	30,3	22	30,2	36	30,0	50	30,3	64	30,8
9	30,4	23	30,3	37	30,0	51	30,3	65	31,3
10	30,2	24	30,2	38	29,8	52	30,2	66	30,9
11	30,2	25	30,3	39	29,7	53	30,4	67	31,0
12	30,4	26	30,1	40	30,0	54	30,4	68	31,1
13	30,3	27	30,3	41	29,9	55	30,1	69	31,3
14	30,2	28	30,2	42	29,9	56	30,1	70	31,2

The fitted linear variogram for the percentage of copper can be calculated as in A.2 and A.3. Fitting a straight line to the first eight points gives the following values for the intercept and slope:

$$A_{\text{exp}} = 0,010\ 8$$

$$B = 1,766 \times 10^{-5} \text{ tonnes}^{-1}$$

Assuming that the preparation and measurement error variance s_{PM}^2 is 0,005 0 (corresponding to a standard error for a single determination of 0,07 % copper), the corrected variogram intercept is thus:

$$A_{\text{cor}} = 0,010\ 8 - \square 0,005\ 0$$

$$= 0,005\ 8$$

Using equation (7) appropriate to stratified systematic sampling, the sampling variance for this stage of sampling is therefore:

$$s_{\text{S}}^2 = \frac{A_{\text{cor}}}{n} + \frac{B \cdot m_{\text{lot}}}{6n^2}$$

$$= \frac{0,005\ 8}{70} + \frac{1,766 \times 10^{-5} \times 35\ 000}{6 \times 70^2}$$

$$= 0,000\ 104$$

Hence:

$$s_{\text{S}} = 0,010$$

so that the standard error of the mean is 0,01 % copper.

The increment variance method can also be used to determine the standard error of the mean. The value of the sample variance s_{Iunc}^2 of the values in Table A.3 is given by:

$$s_{\text{Iunc}}^2 = \frac{1}{n-1} \sum_{i=1}^n (x_i - \bar{x})^2$$

$$= 0,123$$

Correcting for the preparation and measurement variance of 0,005 0, the sampling variance is given by:

$$s_{\text{S}}^2 = \frac{1}{n} (s_{\text{Iunc}}^2 - s_{\text{PM}}^2)$$

$$= \frac{1}{70} (0,123 - 0,005 0)$$

$$= 0,001 69$$

Hence:

$$s_{\text{S}} = 0,041$$

The standard error obtained from the increment variance method is thus 0,04 % copper; i.e. four times too large.

A.5 Calculation of number of increments for a single sampling stage

A lot of 30 000 tonnes of copper concentrate, similar to that described in A.4, is to be sampled using systematic sampling and taking the same increment mass as before. A primary stage sampling variance of 0,000 3 is required. Using equation (29), the number of increments required is:

$$n = \frac{A_{\text{cor}} + \sqrt{A_{\text{cor}}^2 + \frac{2}{3} B \cdot m_{\text{lot}} \cdot s_{\text{S}}^2}}{2s_{\text{S}}^2}$$

$$= \frac{0,005 8 + \sqrt{0,005 8^2 + \frac{2}{3} \times 1,766 \times 10^{-5} \times 30\,000 \times 0,000 3}}{2 \times 0,000 3}$$

$$= 29,4$$

Thus, 30 increments should be taken.

Had the increment variance method been used to design the sampling scheme, the number of increments taken would have been:

$$n = \frac{s_{\text{Iunc}}^2 - s_{\text{PM}}^2}{s_{\text{S}}^2}$$

$$= \frac{0,118}{0,000 3}$$

$$= 393$$

Thus, far more increments than are really necessary would have been taken.

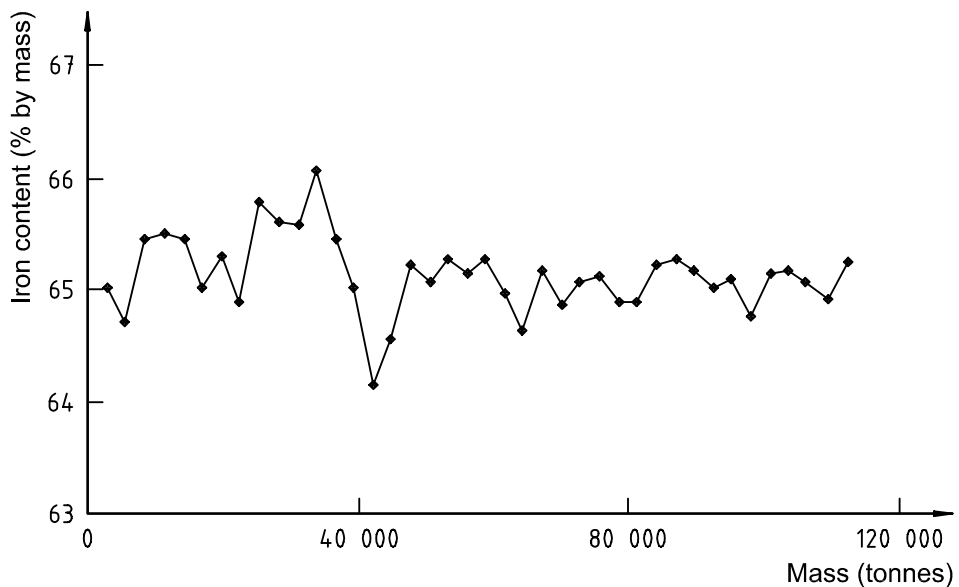
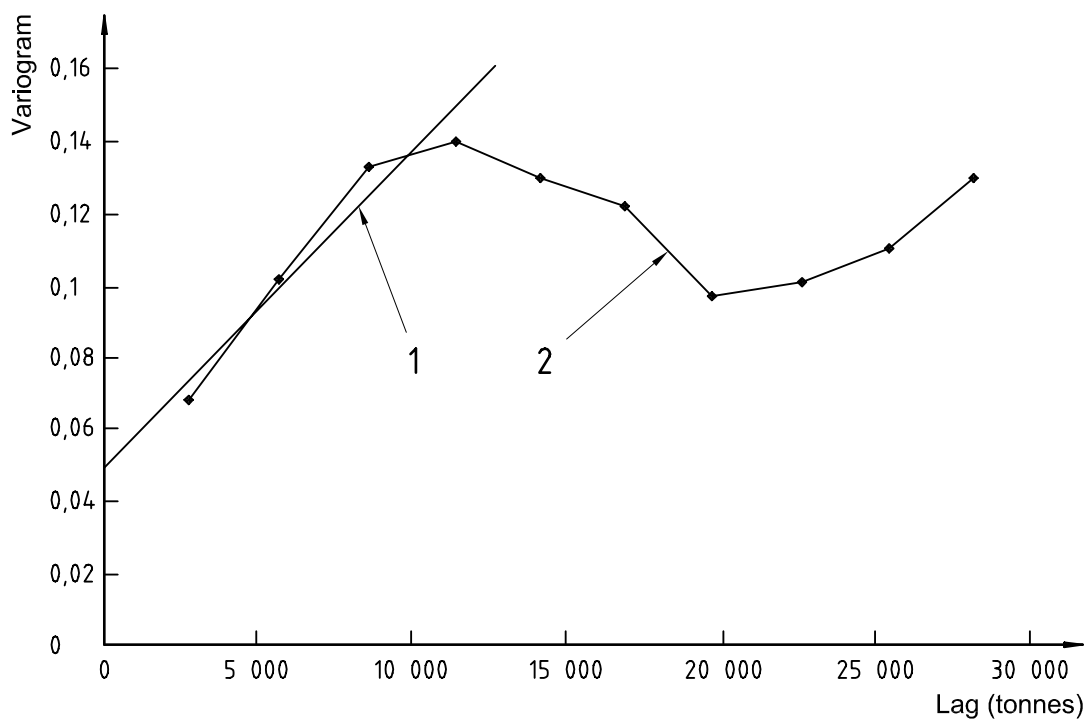

Figure A.1 — Iron content of 40 ore samples



Key

- 1 Linear fit
- 2 Sample variogram

NOTE Linear fit to variogram points at first four lags

Figure A.2 — Sample variogram and linear fit

Annexe B (informative)

Mechanical sampling implements

B.1 General

This annex describes cutters suitable for the mechanical sampling of bulk material from moving streams.

B.2 Types of mechanical sample cutters

Various types of power-operated mechanical sample cutters are available commercially. These usually fall into two general types, namely diverter cutters which divert the increment by gravity, and bucket cutters which collect and hold the increment. The principles of these types are illustrated in Figures B.1 and B.2. Figure B.3 shows a cross-belt sample cutter.

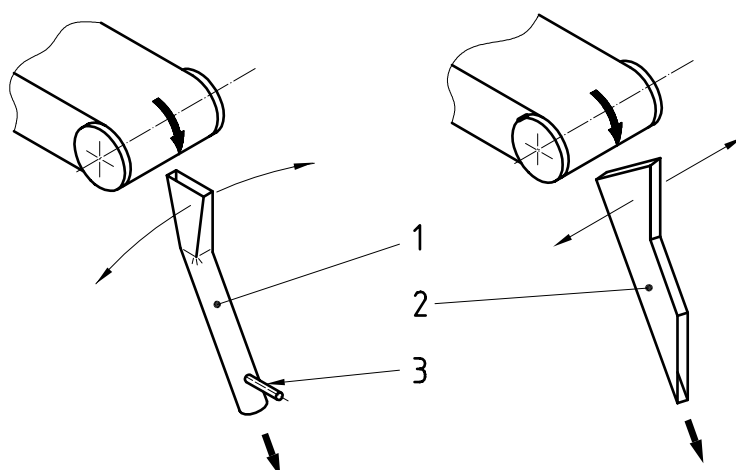

Key

- 1 Radial
- 2 Linear
- 3 Pivot point

a) In-line diverter chutes

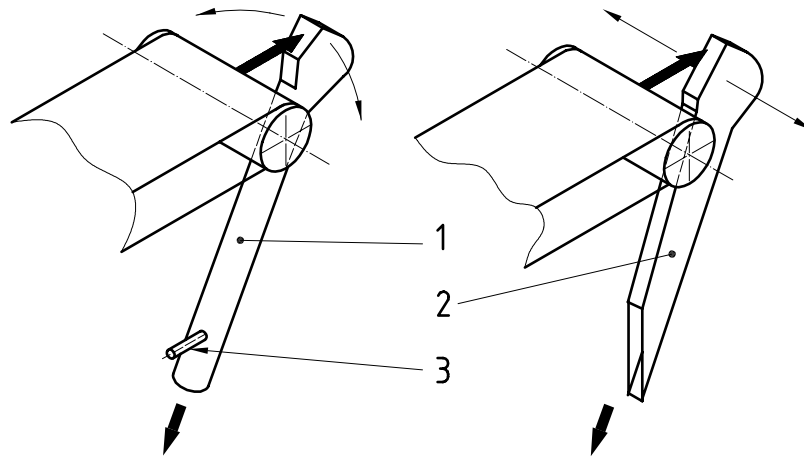

Key

- 1 Radial
- 2 Linear
- 3 Pivot point

b) Reverse spoon diverter chutes

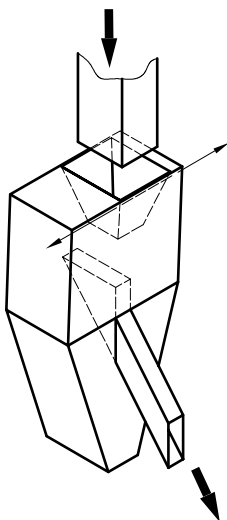

c) Moving hopper

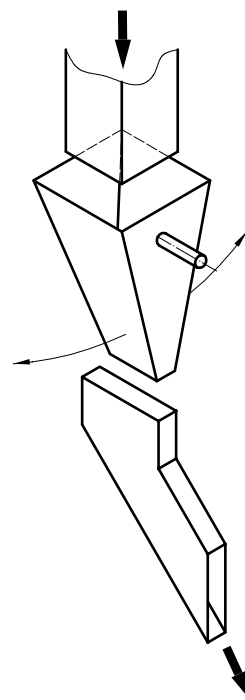

d) Fixed cutter

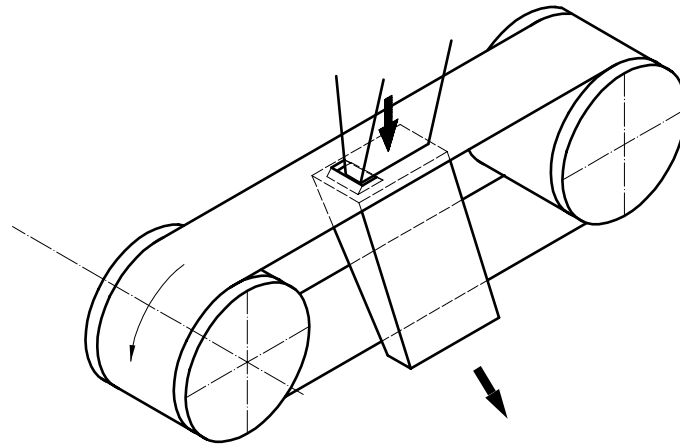

e) Slotted belt

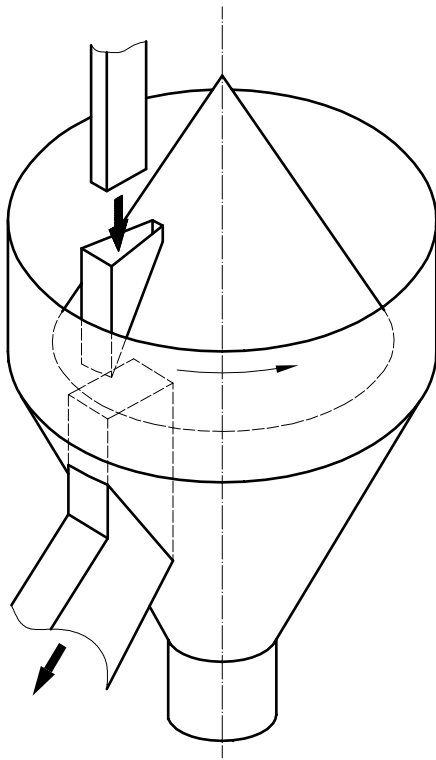

f) Rotary cone

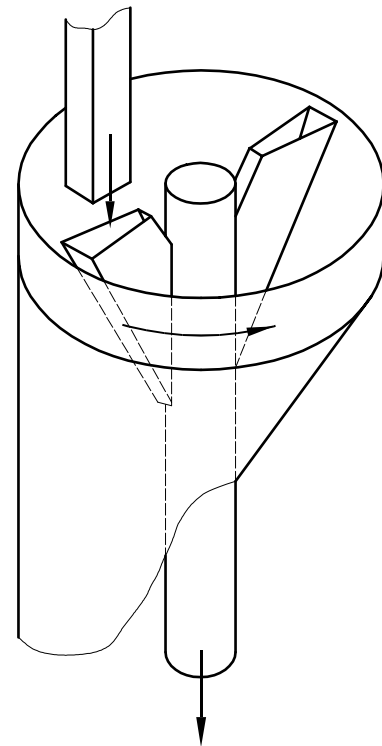

g) Vezin

Figure B.1 — Diverter culture

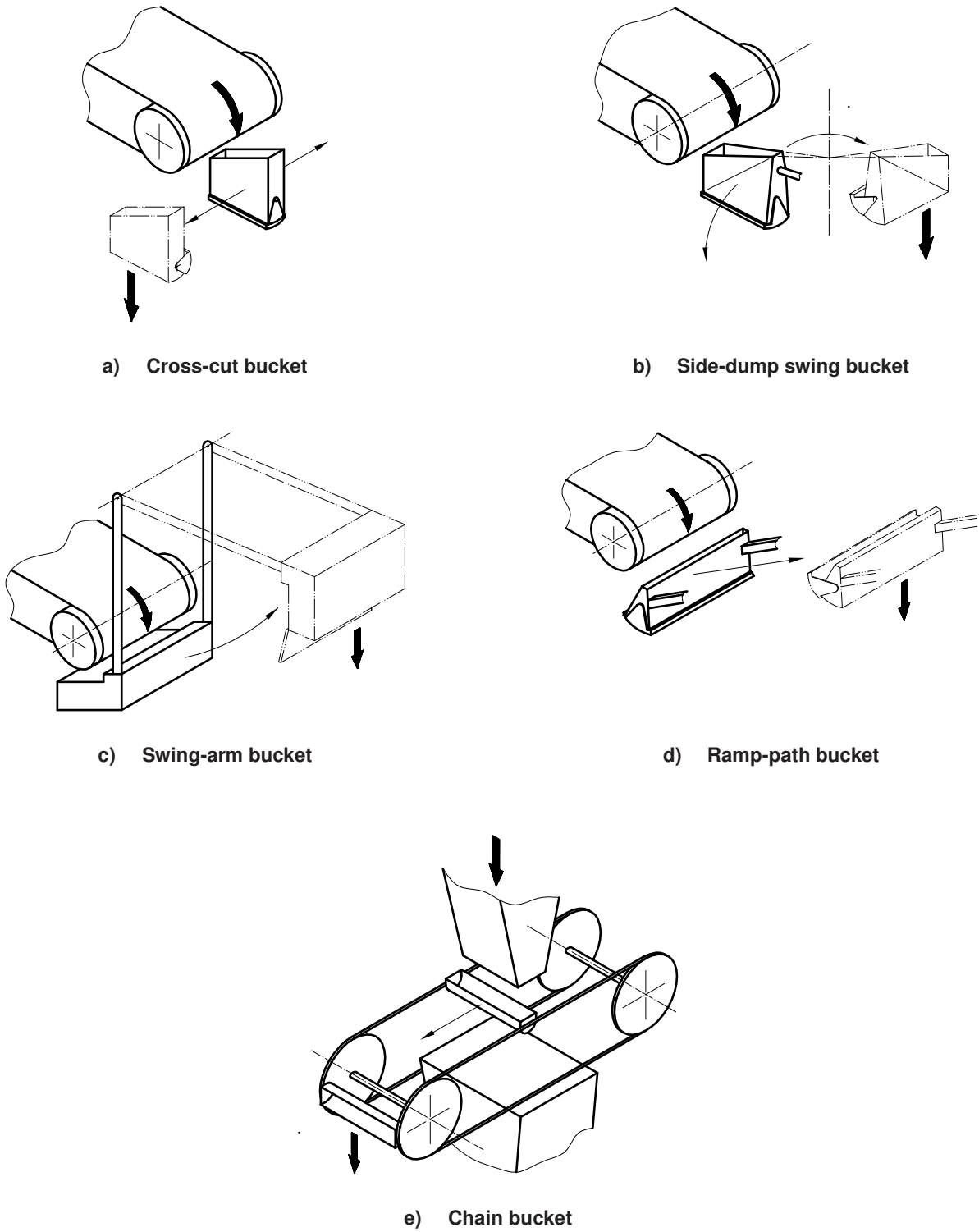

Figure B.2 — Bucket cutters

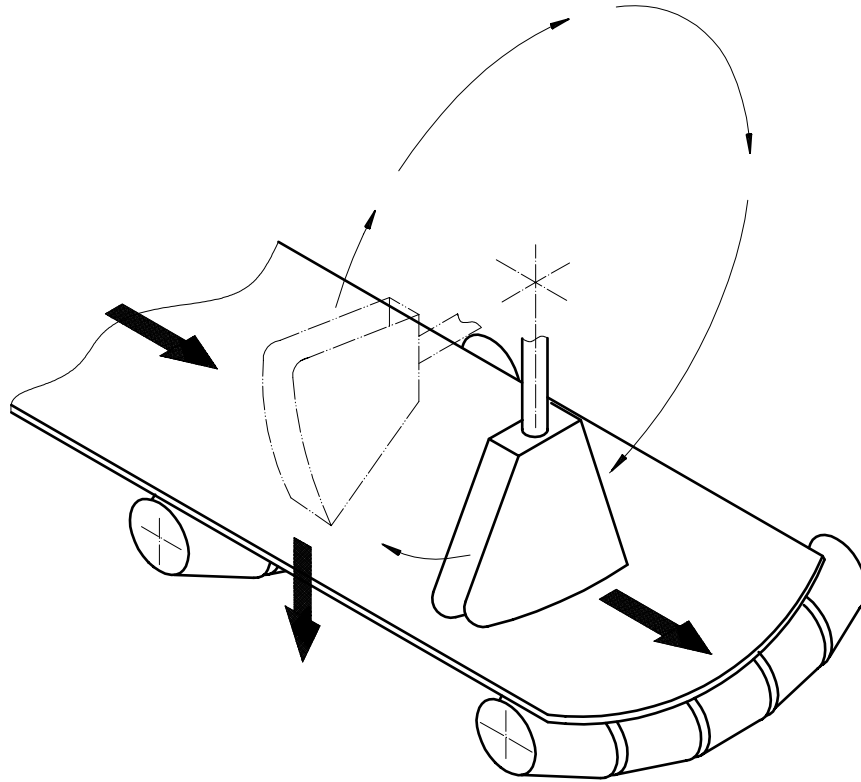

Figure B.3 — Cross-belt sample cutter

Annexe C (informative)

Manual sampling implements form moving streams

C.1 Scope

This annex describes implements suitable for the manual collection of samples of bulk material from moving streams. A recommended design for a ladle is shown in Figure C.1 with recommended dimensions. A recommended design for a manual cutter is shown in Figure C.2. For safety reasons, these implements are not suitable for sampling moving bulk material with a nominal top size larger than 31,5 mm.

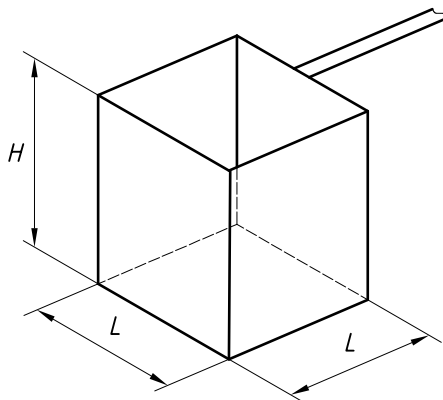

Nominal top size of material mm	Mass of increment ^a kg	Recommended dimensions	
		<i>L</i> mm	<i>H</i> mm
11,2	0,1	40	50
16,0	0,2	55	75
22,4	0,6	80	95
31,5	1,7	110	140

^a Based on a bulk density of 1,0 tonne·m⁻³

Figure C.1 — Manual sampling implements for moving streams

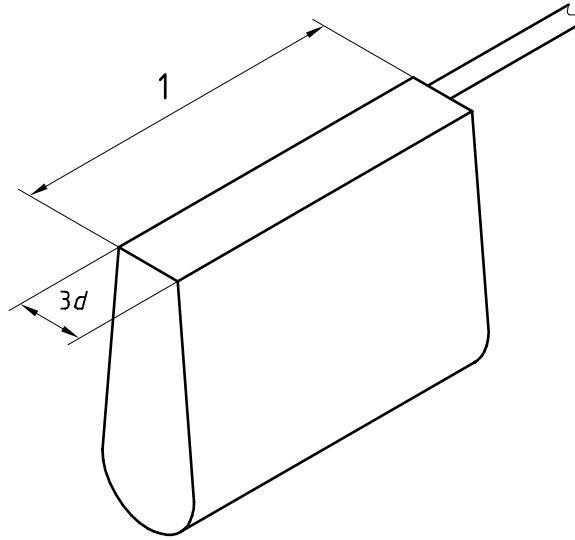
**Key**

1 Length to exceed the depth of the falling stream

Figure C.2 — Manual cutter

Annexe D (informative)

Sampling implements for stationary situations

D.1 General

This annex describes apparatus for manual sampling of bulk material from stationary situations.

D.2 Sampling frame

A sampling frame suitable for use on stopped conveyors is shown in Figure D.1.

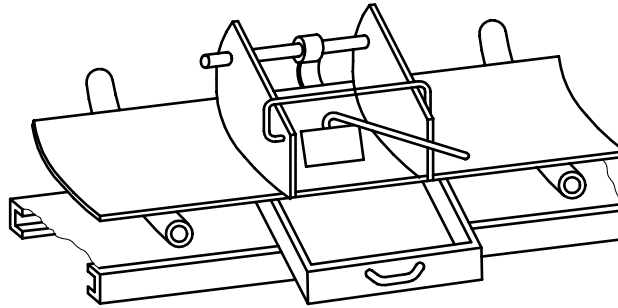
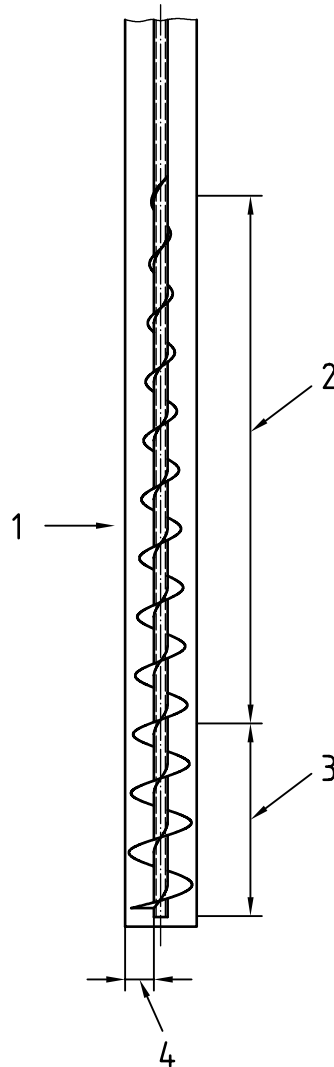

Figure D.1 — Sampling frame

D.3 Mechanical auger

The Archimedian screw of a mechanical auger suitable for sampling from stationary situations is represented in Figure D.2.



Key

- 1 Auger tube
- 2 Tapered flights
- 3 Full flights
- 4 Cutter width (= 3 × top size)

Figure D.2 — Example of a mechanical auger screw

D.4 Spear

A spear suitable for sampling moist bulk material of nominal top size less than 10 mm from trucks or wagons is represented in Figure D.3.

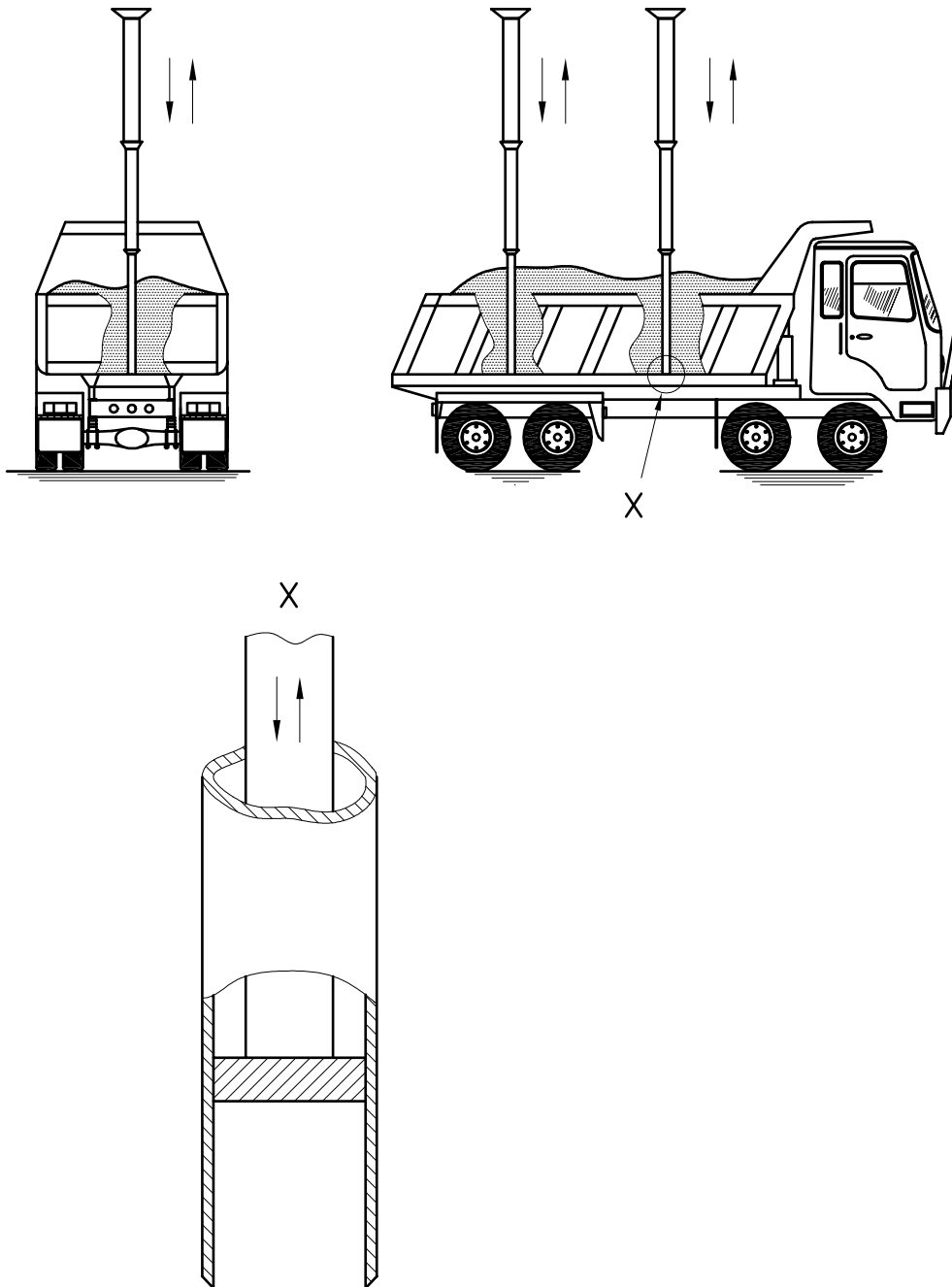
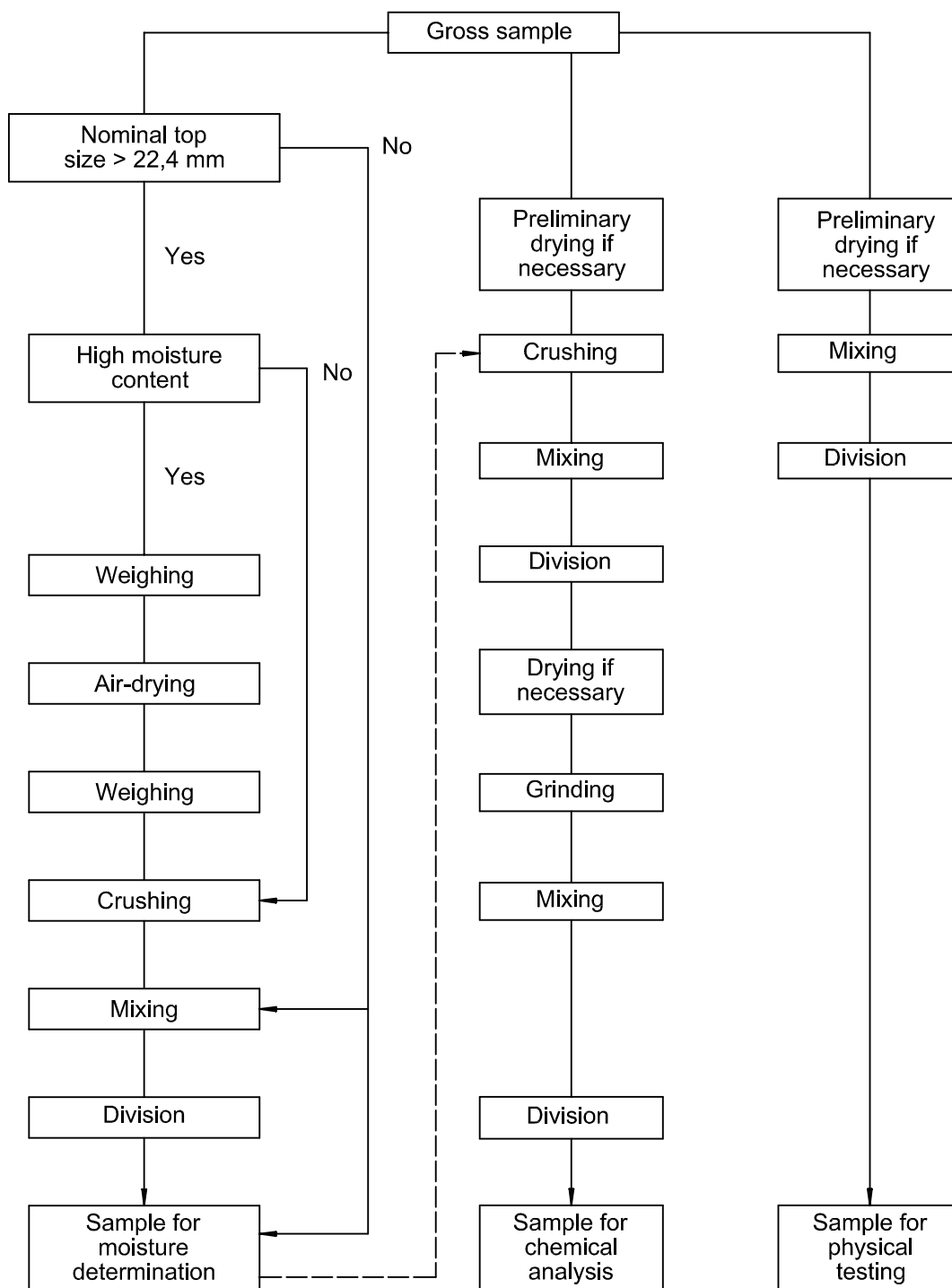

Figure D.3 — Manual-type spear

Annexe E (informative)

Sample preparation schemes

Schemes for sample preparation are given in Figures E.1 and E.2.



NOTE Sample used for moisture determination may be used for chemical analysis if desired.

Figure E.1 — Sample preparation from a gross sample

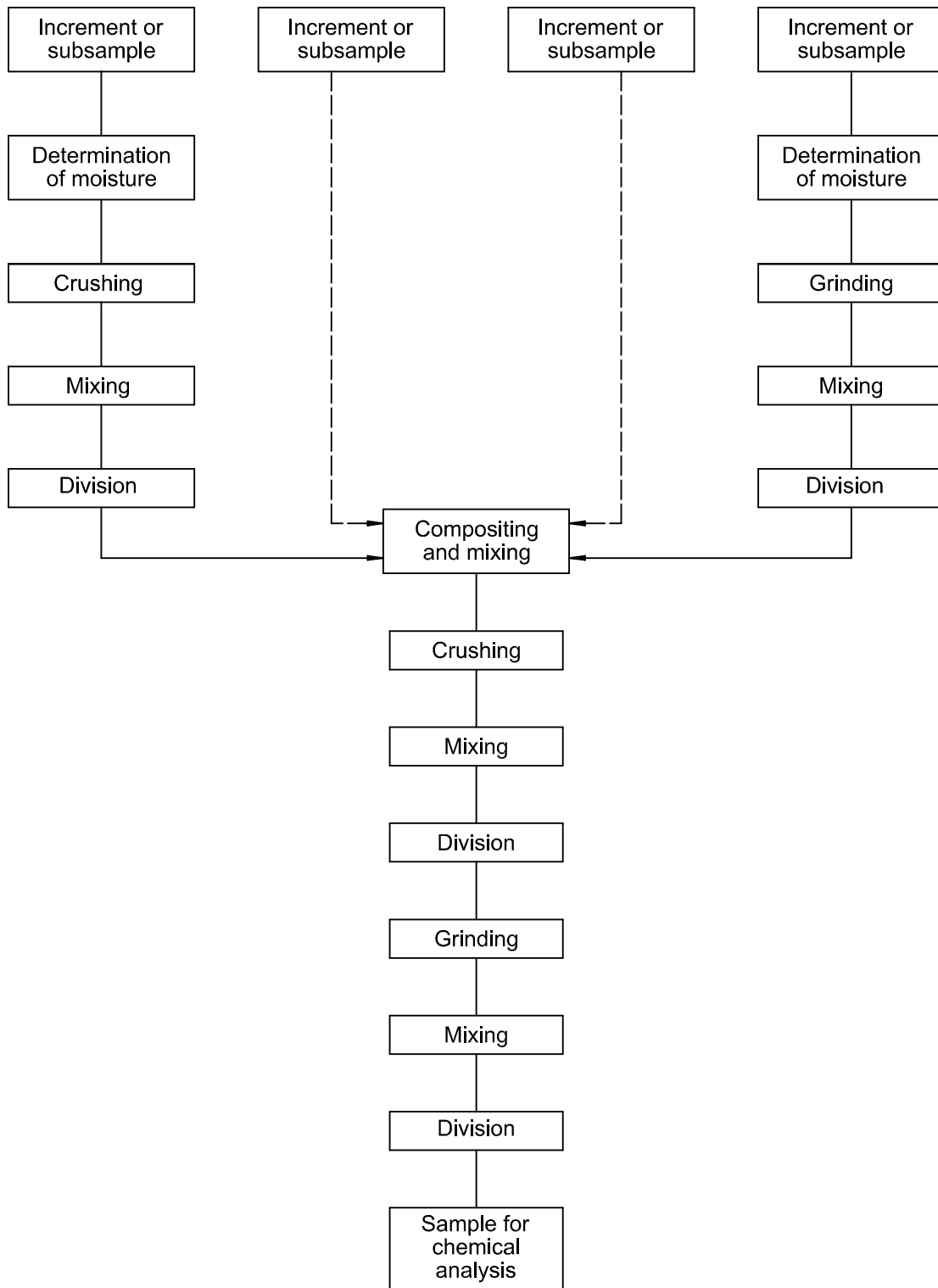

Figure E.2 — Sample preparation from increments or sub-lot samples

Annexe F (informative)

Particle-size reduction equipment

Typical equipment to reduce particle size is illustrated in Figures F.1 to F.4.

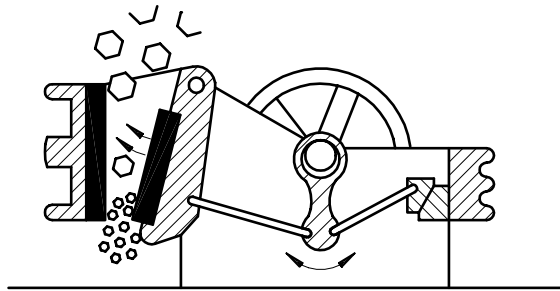

Figure F.1 — Jaw crusher

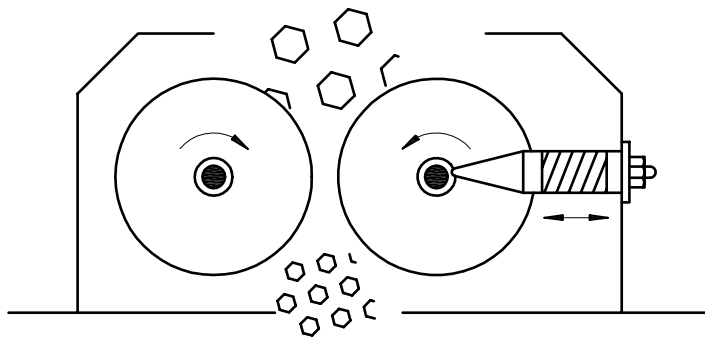
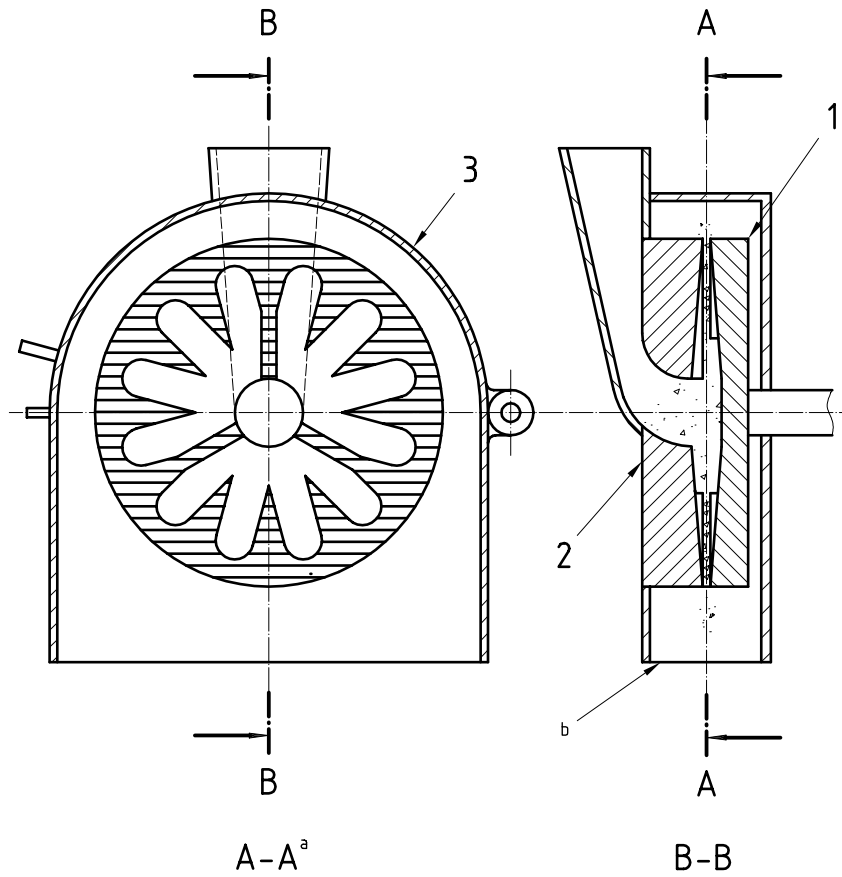

Figure F.2 — Roll crusher



Key

- 1 Rotating grinding plate
- 2 Fixed grinding plate
- 3 Hinged cover

- a View of plate detail
- b Discharge

Figure F.3 — Plate mill

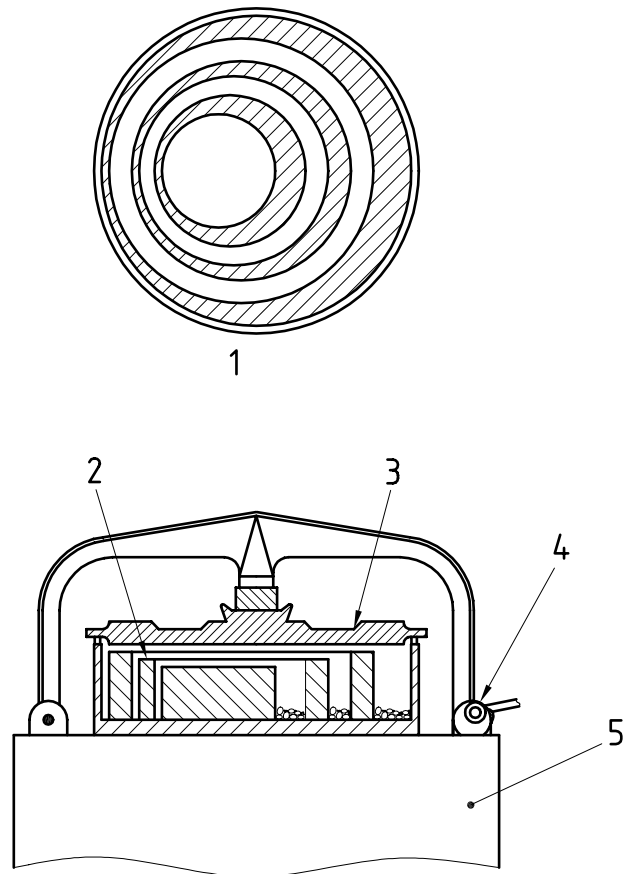
**Key**

- 1 Top view of rings
- 2 Rings
- 3 Lid
- 4 Toggle clamp
- 5 Vibrating table

NOTE Ring mill material is placed in the spaces between the loose rings, wall and centre disc. Milling is induced by a vibrating table on which the milling chamber is clamped.

Figure F.4 — Ring mill

Annexe G (informative)

Examples of mechanical mixers

Examples of mechanical mixers are illustrated in Figures G.1 and G.2.

A double-cone mixer is shown in Figure G.1 and is suitable for mixing the residue from the first stage of sample division. It has a short cylindrical portion, an inclined baffle plate and a closure plate at either end and is secured by bearings mounted on a suitable support. The mixer rotates at approximately 60 r/min. For quantities up to 0,25 kg, mixing for 1 min is sufficient, but for larger quantities, mixing for approximately 4 min is necessary.

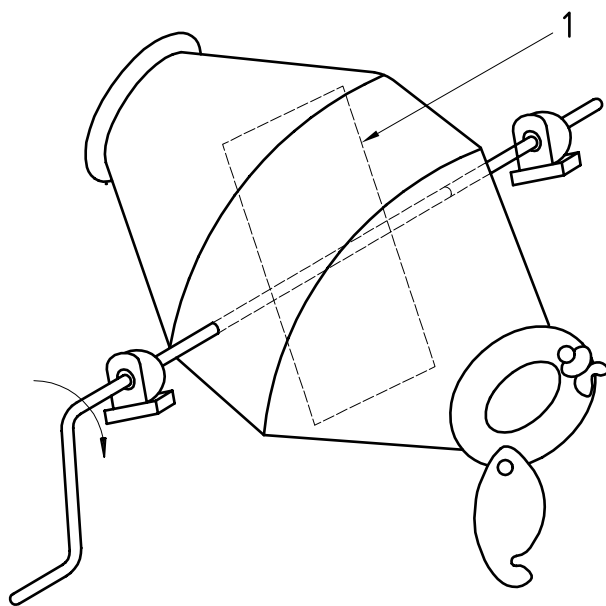

Key

1 Baffle plate

Length: 400 mm

Maximum diameter: 330 mm

Figure G.1 — Double-cone mixer

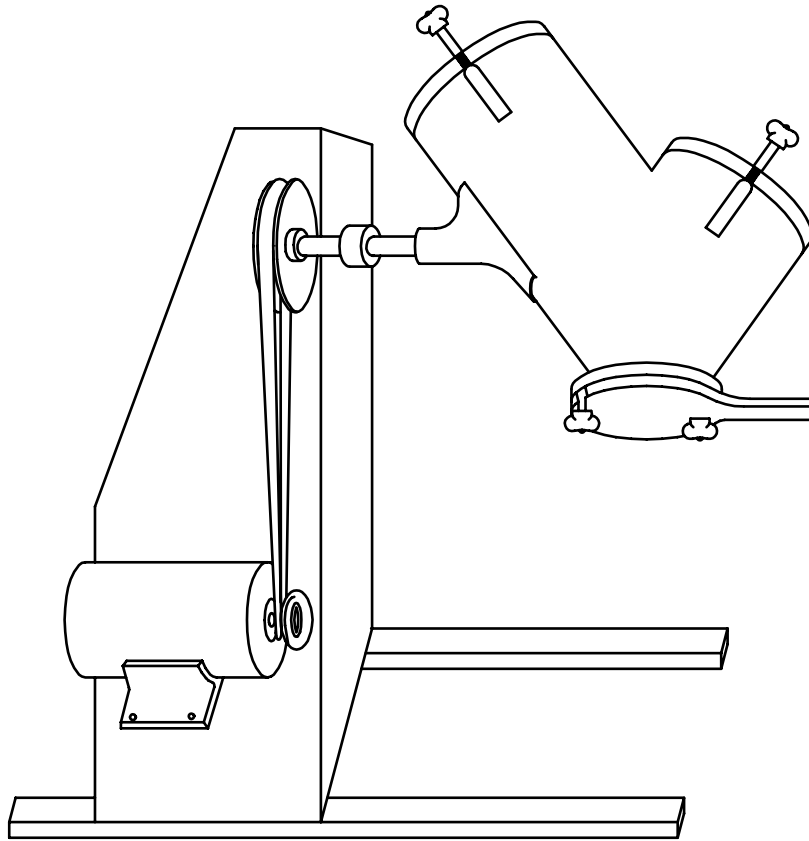

Figure G.2 — V-style solids blender

Annexe H
(informative)

Mechanical sample dividers

Examples of mechanical sample dividers are illustrated in Figures H.1 and H.2.

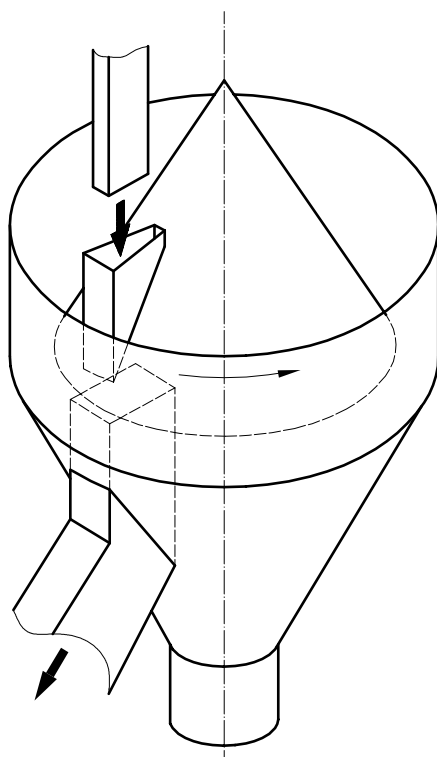
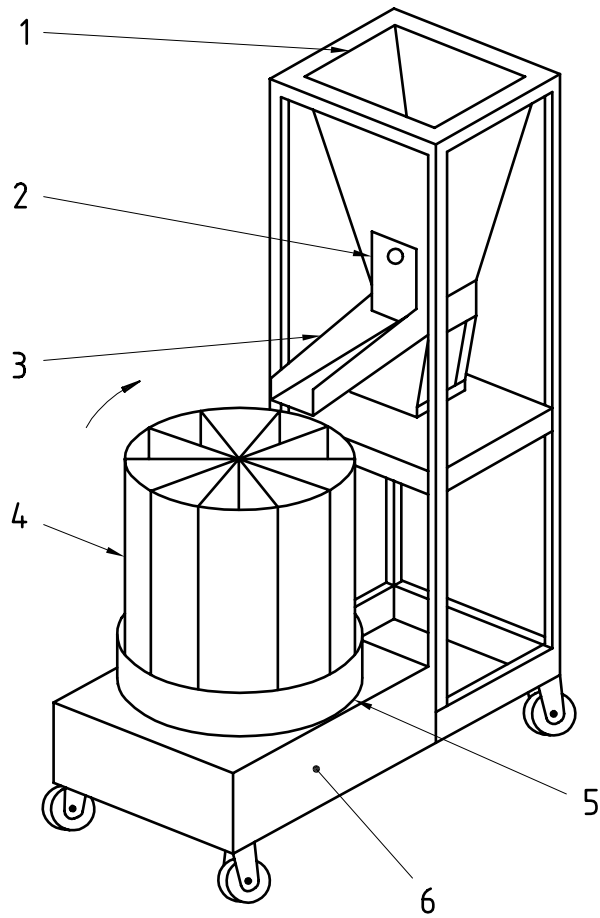

Figure H.1 — Rotating cone

**Key**

- 1 Feed hopper
- 2 Slide gate
- 3 Vibratory feeder
- 4 Removable canisters
- 5 Turntable
- 6 Drive (enclosed)

Figure H.2 — An example of a rotary sample divider

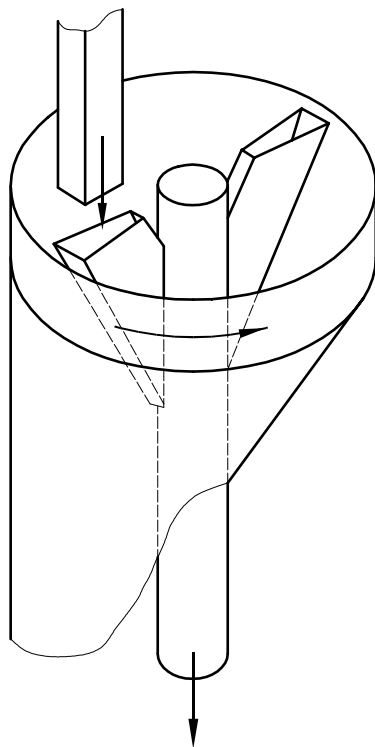

Figure H.3 — Rotating chute

Annexe I (informative)

Implements for manual sample division

I.1 General

This annex describes implements suitable for manual sample division.

I.2 Scoops

A recommended design for a scoop is shown in Figure I.1 and the recommended dimensions are given in Table I.1. Scoops are not suitable for sampling bulk material with a nominal top size larger than about 45 mm.

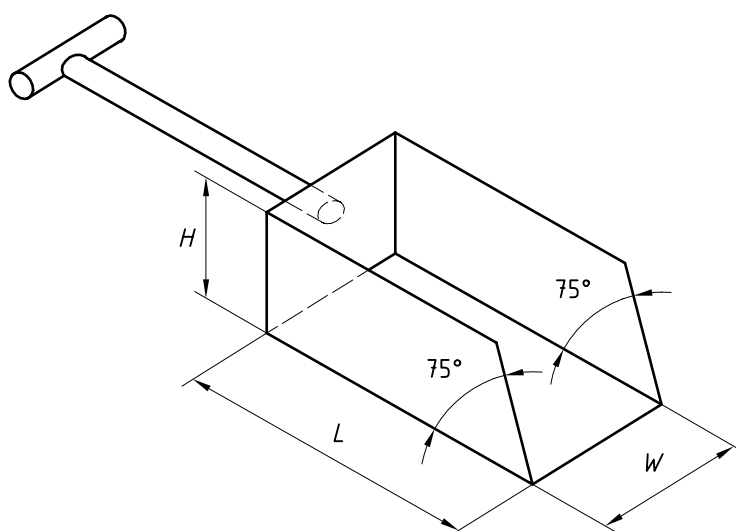

Figure I.1 — Scoop

Table I.1 — Recommended sizes of scoops

Nominal top size of material mm	Minimum mass of increment kg	Recommended dimensions mm		
		<i>L</i>	<i>W</i>	<i>H</i>
11,2	Masses need to be determined; refer to 7.4.	75	35	30
16,0		110	50	40
22,4		170	70	50
31,5		220	95	80
45,0		300	135	120

I.3 Shovels

A recommended design of a shovel is shown in Figure I.2 with the recommended dimensions given in Table I.2. Shovels are not suitable for sampling bulk material with a nominal top size larger than about 63 mm.

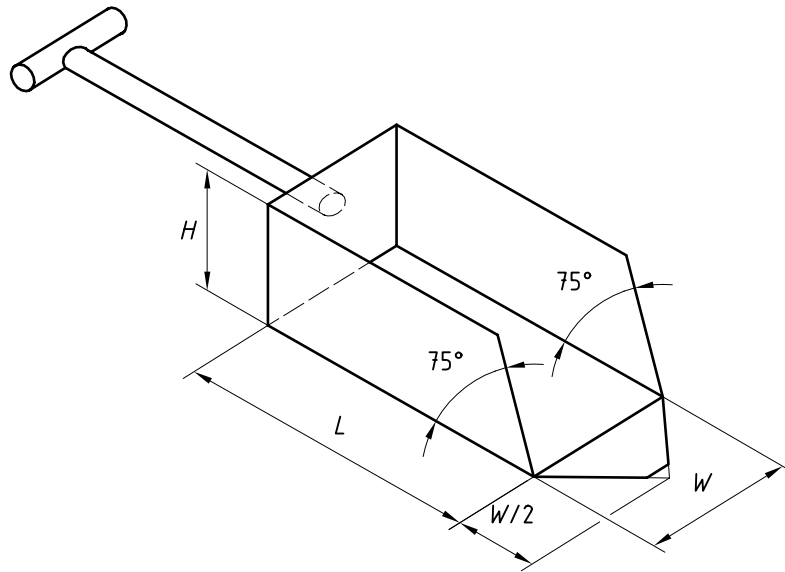

Figure I.2 — Shovel

Table I.2 — Recommended sizes of shovels

Nominal top size of material mm	Minimum mass of increment kg	Recommended dimensions mm		
		L	W	H
11,2	Masses need to be determined; refer to 7.4.	75	35	30
16,0		110	50	40
22,4		170	70	50
45,0		220	95	80
45,0		300	135	120

Annexe J
(informative)

Examples of riffles

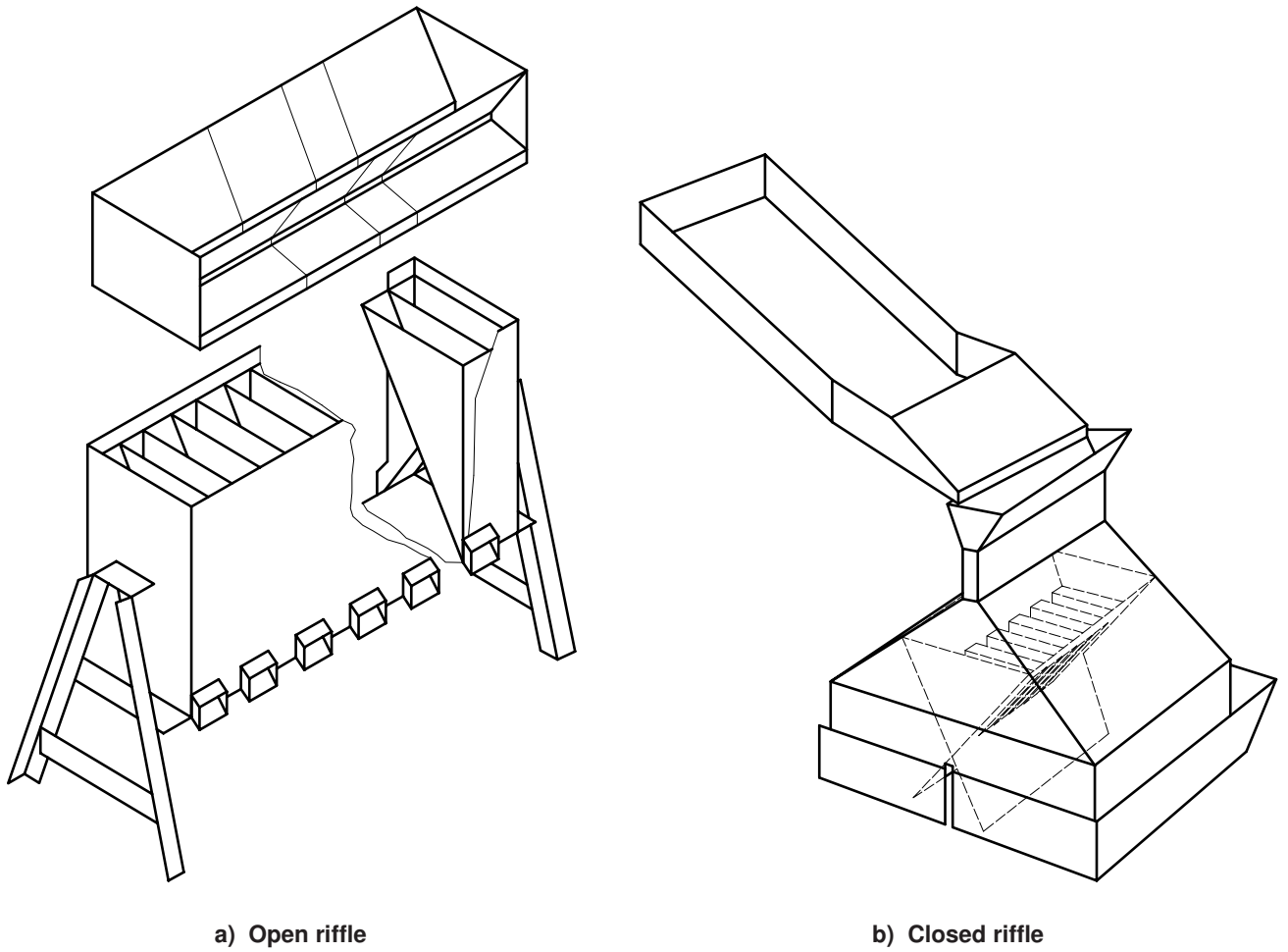

Figure J.1

Bibliography

- [1] GY P.M. *Sampling of Heterogeneous and Dynamic Material Systems*. Elsevier Scientific Publishing, Amsterdam, 1992.
- [2] MERKS J.W. *Sampling and Weighing of Bulk Solids*. Trans Tech Publications, Clausthal-Zellerfeld, Germany, 1st ed., 1985.
- [3] PITARD F.F. *Pierre Gy's Sampling Theory and Sampling Practice*, CRC Press, Boca Raton, USA, 2nd ed., 1993.

BSI — British Standards Institution

BSI is the independent national body responsible for preparing British Standards. It presents the UK view on standards in Europe and at the international level. It is incorporated by Royal Charter.

Revisions

British Standards are updated by amendment or revision. Users of British Standards should make sure that they possess the latest amendments or editions.

It is the constant aim of BSI to improve the quality of our products and services. We would be grateful if anyone finding an inaccuracy or ambiguity while using this British Standard would inform the Secretary of the technical committee responsible, the identity of which can be found on the inside front cover. Tel: +44 (0)20 8996 9000. Fax: +44 (0)20 8996 7400.

BSI offers members an individual updating service called PLUS which ensures that subscribers automatically receive the latest editions of standards.

Buying standards

Orders for all BSI, international and foreign standards publications should be addressed to Customer Services. Tel: +44 (0)20 8996 9001. Fax: +44 (0)20 8996 7001. Email: orders@bsi-global.com. Standards are also available from the BSI website at <http://www.bsi-global.com>.

In response to orders for international standards, it is BSI policy to supply the BSI implementation of those that have been published as British Standards, unless otherwise requested.

Information on standards

BSI provides a wide range of information on national, European and international standards through its Library and its Technical Help to Exporters Service. Various BSI electronic information services are also available which give details on all its products and services. Contact the Information Centre. Tel: +44 (0)20 8996 7111. Fax: +44 (0)20 8996 7048. Email: info@bsi-global.com.

Subscribing members of BSI are kept up to date with standards developments and receive substantial discounts on the purchase price of standards. For details of these and other benefits contact Membership Administration. Tel: +44 (0)20 8996 7002. Fax: +44 (0)20 8996 7001. Email: membership@bsi-global.com.

Information regarding online access to British Standards via British Standards Online can be found at <http://www.bsi-global.com/bsonline>.

Further information about BSI is available on the BSI website at <http://www.bsi-global.com>.

Copyright

Copyright subsists in all BSI publications. BSI also holds the copyright, in the UK, of the publications of the international standardization bodies. Except as permitted under the Copyright, Designs and Patents Act 1988 no extract may be reproduced, stored in a retrieval system or transmitted in any form or by any means – electronic, photocopying, recording or otherwise – without prior written permission from BSI.

This does not preclude the free use, in the course of implementing the standard, of necessary details such as symbols, and size, type or grade designations. If these details are to be used for any other purpose than implementation then the prior written permission of BSI must be obtained.

Details and advice can be obtained from the Copyright & Licensing Manager. Tel: +44 (0)20 8996 7070. Fax: +44 (0)20 8996 7553. Email: copyright@bsi-global.com.