



BSI Standards Publication

Road vehicles — Component test methods for electrical disturbances from narrowband radiated electromagnetic energy

Part 3: Transverse electromagnetic (TEM) cell

National foreword

This British Standard is the UK implementation of ISO 11452-3:2016.

The UK participation in its preparation was entrusted to Technical Committee AUE/32, Electrical and electronic components and general system aspects (Road vehicles).

A list of organizations represented on this committee can be obtained on request to its secretary.

This publication does not purport to include all the necessary provisions of a contract. Users are responsible for its correct application.

© The British Standards Institution 2016.

Published by BSI Standards Limited 2016

ISBN 978 0 580 87192 4

ICS 33.100.20; 43.040.10

Compliance with a British Standard cannot confer immunity from legal obligations.

This British Standard was published under the authority of the Standards Policy and Strategy Committee on 30 September 2016.

Amendments/corrigenda issued since publication

Date	Text affected
------	---------------

**Road vehicles — Component test
methods for electrical disturbances
from narrowband radiated
electromagnetic energy —**

Part 3:

Transverse electromagnetic (TEM) cell

*Véhicules routiers — Méthodes d'essai d'un équipement soumis
à des perturbations électriques par rayonnement d'énergie
électromagnétique en bande étroite —*

Partie 3: Cellule électromagnétique transverse (TEM)





COPYRIGHT PROTECTED DOCUMENT

© ISO 2016, Published in Switzerland

All rights reserved. Unless otherwise specified, no part of this publication may be reproduced or utilized otherwise in any form or by any means, electronic or mechanical, including photocopying, or posting on the internet or an intranet, without prior written permission. Permission can be requested from either ISO at the address below or ISO's member body in the country of the requester.

ISO copyright office
Ch. de Blandonnet 8 • CP 401
CH-1214 Vernier, Geneva, Switzerland
Tel. +41 22 749 01 11
Fax +41 22 749 09 47
copyright@iso.org
www.iso.org

Contents

	Page
Foreword	iv
Introduction	v
1 Scope	1
2 Normative references	1
3 Terms and definitions	1
4 Test conditions	1
5 Test apparatus	2
5.1 TEM cell.....	2
5.2 Instrumentation.....	3
5.3 Test set-up.....	3
5.3.1 General.....	3
5.3.2 Exposure of device under test and wiring harness (for major field coupling to the harness).....	4
5.3.3 Exposure of device under test alone (for major field coupling to that device).....	6
6 Test procedure	7
6.1 Test plan.....	7
6.2 Test method.....	7
6.2.1 General.....	7
6.2.2 Test level setting.....	7
6.2.3 DUT test.....	8
6.3 Test report.....	8
Annex A (informative) TEM cell dimensions	10
Annex B (informative) Calculations and measurements of TEM-cell frequency range	12
Annex C (informative) Installation of external components and low pass filter design	14
Annex D (informative) Test setup without low pass filters	17
Annex E (informative) Function performance status classification (FPSC) and test severity levels	20
Bibliography	21

Foreword

ISO (the International Organization for Standardization) is a worldwide federation of national standards bodies (ISO member bodies). The work of preparing International Standards is normally carried out through ISO technical committees. Each member body interested in a subject for which a technical committee has been established has the right to be represented on that committee. International organizations, governmental and non-governmental, in liaison with ISO, also take part in the work. ISO collaborates closely with the International Electrotechnical Commission (IEC) on all matters of electrotechnical standardization.

The procedures used to develop this document and those intended for its further maintenance are described in the ISO/IEC Directives, Part 1. In particular the different approval criteria needed for the different types of ISO documents should be noted. This document was drafted in accordance with the editorial rules of the ISO/IEC Directives, Part 2 (see www.iso.org/directives).

Attention is drawn to the possibility that some of the elements of this document may be the subject of patent rights. ISO shall not be held responsible for identifying any or all such patent rights. Details of any patent rights identified during the development of the document will be in the Introduction and/or on the ISO list of patent declarations received (see www.iso.org/patents).

Any trade name used in this document is information given for the convenience of users and does not constitute an endorsement.

For an explanation on the meaning of ISO specific terms and expressions related to conformity assessment, as well as information about ISO's adherence to the World Trade Organization (WTO) principles in the Technical Barriers to Trade (TBT) see the following URL: www.iso.org/iso/foreword.html.

The committee responsible for this document is ISO/TC 22, *Road vehicles*, Subcommittee SC 32, *Electrical and electronic components and general system aspects*.

This third edition cancels and replaces the second edition (ISO 11452-3:2001), which has been technically revised with the following changes:

- the use of forward power as the levelling parameter to make it consistent with the other ISO 11452 standards has been implemented;
- [Annex D](#) for testing of devices without using low pass filters has been included.

A list of all parts in the ISO 11452 series can be found on the ISO website.

Introduction

Immunity measurements of complete road vehicles are generally able to be carried out only by the vehicle manufacturer, owing to, for example, high costs of absorber-lined shielded enclosures, the desire to preserve the secrecy of prototypes or a large number of different vehicle models.

For research, development and quality control, a laboratory measuring method can be used by both vehicle manufacturers and equipment suppliers to test electronic components.

The TEM cell method has the major advantage of not radiating energy into the surrounding environment. The method can be used for testing either the immunity of a component with the field coupling to the wiring harness or the immunity of the component alone with minimum exposure to the wiring harness.

Road vehicles — Component test methods for electrical disturbances from narrowband radiated electromagnetic energy —

Part 3: Transverse electromagnetic (TEM) cell

1 Scope

This document specifies transverse electromagnetic (TEM) cell tests for determining the immunity of electronic components of passenger cars and commercial vehicles to electrical disturbances from narrowband radiated electromagnetic energy, regardless of the vehicle propulsion system (e.g. spark-ignition engine, diesel engine, electric motor).

The electromagnetic disturbances considered are limited to continuous narrowband electromagnetic fields.

2 Normative references

The following documents are referred to in the text in such a way that some or all of their content constitutes requirements of this document. For dated references, only the edition cited applies. For undated references, the latest edition of the referenced document (including any amendments) applies.

ISO 11452-1, *Road vehicles — Component test methods for electrical disturbances from narrowband radiated electromagnetic energy — Part 1: General principles and terminology*

3 Terms and definitions

For the purposes of this document, the terms and definitions given in ISO 11452-1 apply.

ISO and IEC maintain terminological databases for use in standardization at the following addresses:

- IEC Electropedia: available at <http://www.electropedia.org/>
- ISO Online browsing platform: available at <http://www.iso.org/obp>

4 Test conditions

The upper frequency range limit of the TEM cell is a direct function of the TEM cell dimensions.

For testing automotive electronic systems, a 0,01 MHz to 200 MHz TEM cell should be used. See [Annex A](#) for suggested cell dimensions.

The user shall specify the test severity level or levels over the frequency range. See [Annex E](#) for suggested test severity levels.

Standard test conditions shall be those given in ISO 11452-1 for the following:

- test temperature;
- supply voltage;

- modulation;
- dwell time;
- frequency step sizes;
- definition of test severity levels;
- test-signal quality.

5 Test apparatus

5.1 TEM cell

The TEM cell used for this test is a rectangular coaxial line with a 50 Ω characteristic impedance (see [Figure 1](#)). The device under test is exposed to a uniform TEM field.

The TEM cell is a laboratory measurement system which can be used to generate test fields within 2 dB of the theoretical value if the device under test does not occupy an excessive portion of the test volume (see [5.3](#)).

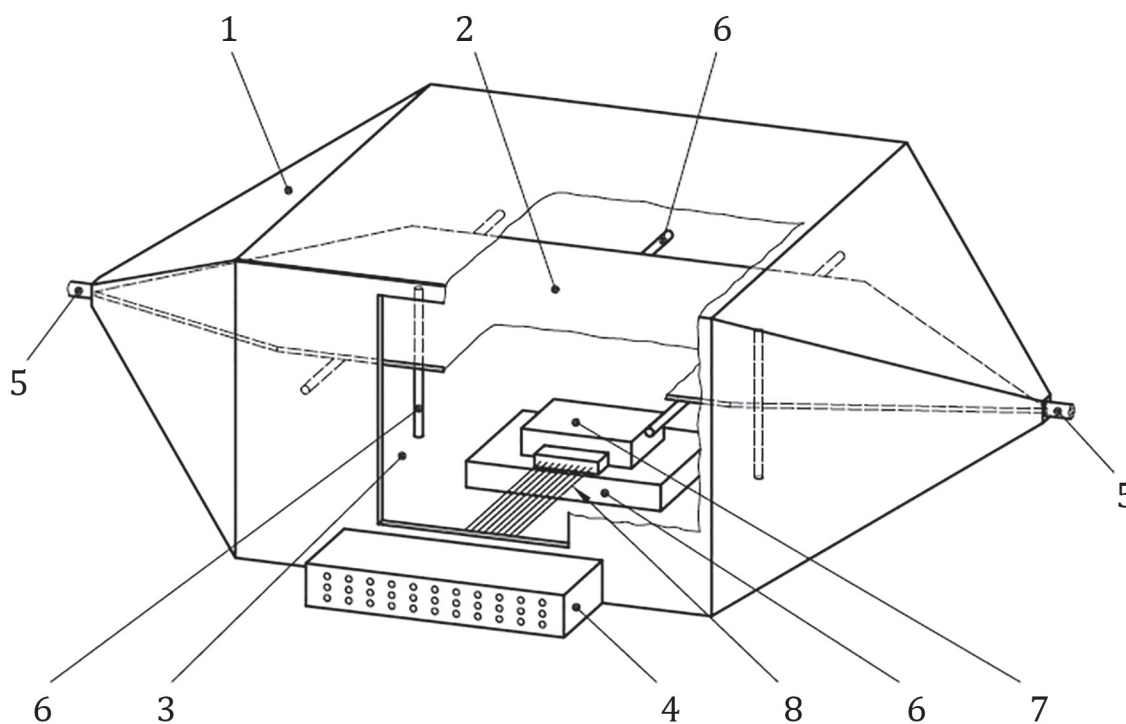

Key

- 1 outer conductor (shield)
- 2 septum (inner conductor)
- 3 access door
- 4 connector panel (optional)
- 5 coaxial connectors
- 6 dielectric support (relative permittivity $\epsilon_r \leq 1,4$)
- 7 device under test
- 8 input/output leads

Figure 1 — TEM cell

5.2 Instrumentation

Figure 2 shows an example of a TEM cell test set-up. The TEM cell has high resonances in the region greater than the recommended upper frequency limit.

A low pass filter with an attenuation of at least 60 dB at frequencies above 1,5 times the cut-off frequency of the TEM cell may be installed (e.g. 200 MHz TEM cell: 60 dB for frequencies above 300 MHz) to avoid resonances.

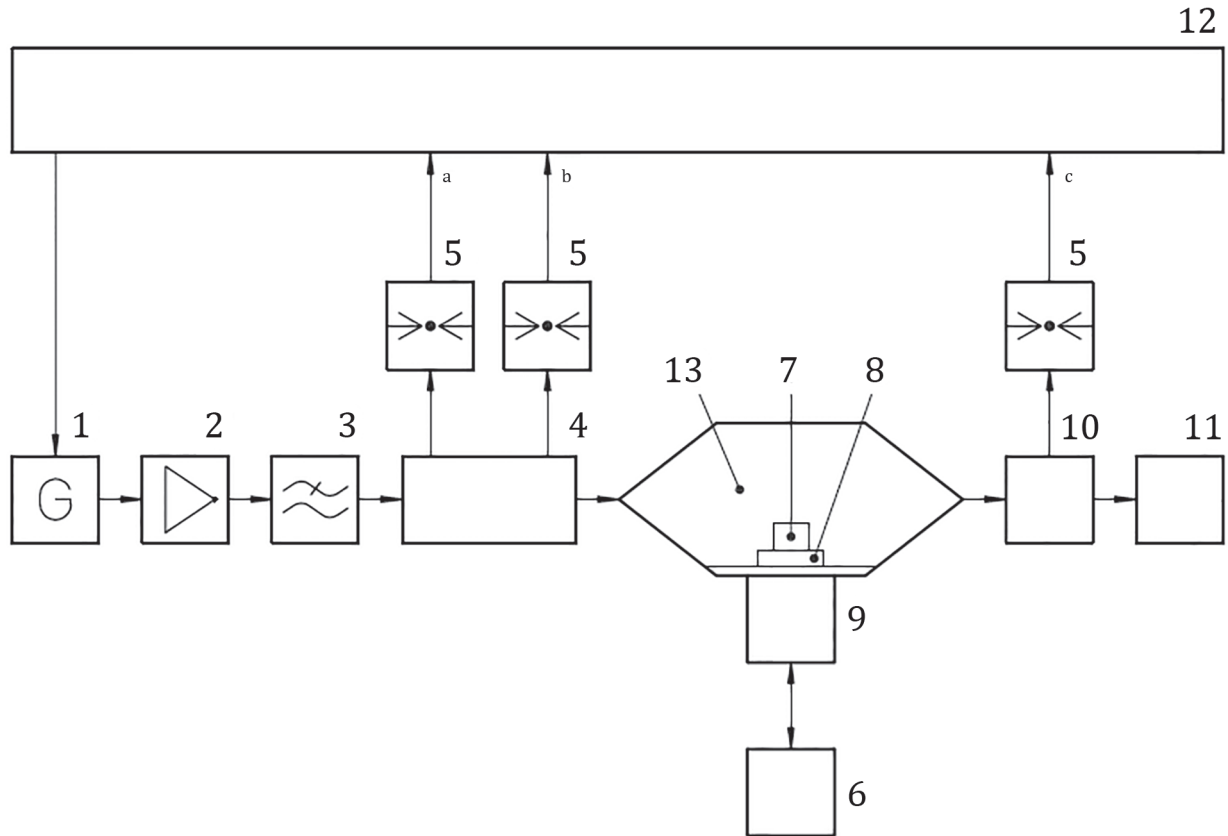

Key

- | | | | |
|---|---|----|--|
| 1 | signal generator | 9 | low pass filters/connector panel |
| 2 | broadband amplifier | 10 | coupler |
| 3 | low pass filter (optional) | 11 | high power load (50 Ω) |
| 4 | dual-directional coupler (30 dB decoupling ratio minimum) | 12 | controller |
| 5 | RF-power meter | 13 | TEM cell |
| 6 | peripheral | a | P_{forward} (forward power) |
| 7 | device under test | b | $P_{\text{reflected}}$ (reflected power) |
| 8 | dielectric support | c | P_{output} (output power) |

Figure 2 — Example TEM cell configuration

5.3 Test set-up

5.3.1 General

In order to maintain the homogeneous field in the TEM cell and obtain reproducible measurement results, the device under test shall be no larger than one-sixth of the cell (inside) height, b (see Figure 3

and [Figure A.1](#)). The device under test should be placed in the centre of the cell on a dielectric equipment support.

The device under test and the wiring harness may be positioned in either of two arrangements, depending on whether the exposure of the device under test and the wiring harness (see [5.3.2](#)) or that of the device alone (see [5.3.3](#)) is being tested.

An alternative test set-up without low pass filter is presented in [Annex D](#).

5.3.2 Exposure of device under test and wiring harness (for major field coupling to the harness)

The height of the dielectric support is one-sixth of cell height b (see [Figure 3](#)). In order to obtain reproducible measurement results, the device under test, together with its wiring harness or printed circuit board, shall be placed in the same position in the TEM cell for each measurement. In addition to the direct RF-field coupling to the device under test, the use of an unshielded harness or printed circuit board will result in a common mode electrical field coupling and a differential mode magnetic field coupling, depending on the inclination and the width of the harness or circuit board.

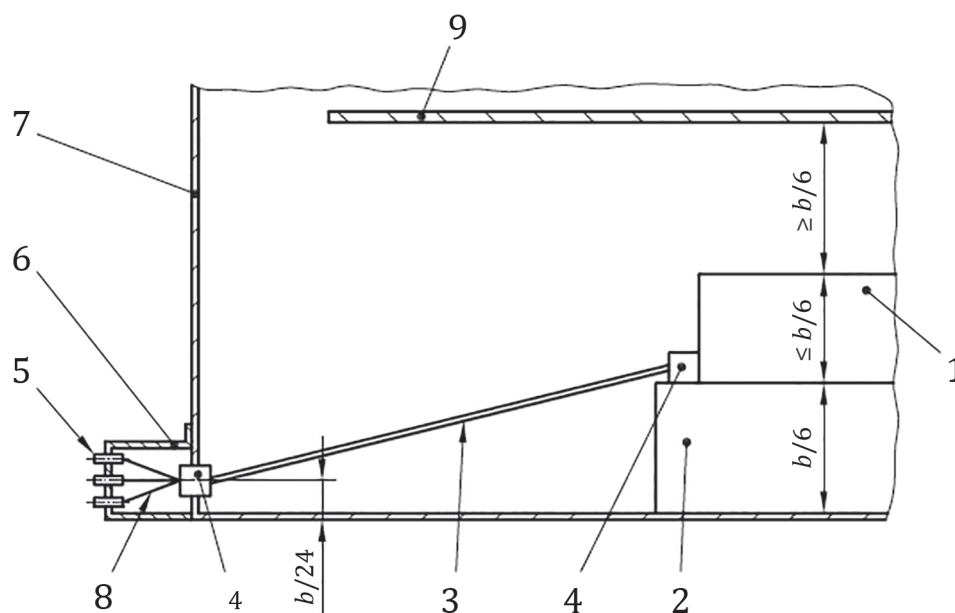

Key

- 1 device under test
- 2 dielectric support (relative permittivity $\epsilon_r \leq 1,4$)
- 3 printed circuit board (no ground plane) or wiring harness, unshielded
- 4 connector
- 5 coaxial connectors
- 6 connector panel
- 7 TEM cell wall
- 8 cables
- 9 septum
- b TEM cell height (see [Annex A](#))

Figure 3 — Example test set-up — Major field coupling to wiring harness (side view)

The connector panel should be attached to the TEM cell as close as possible to the printed lead system. The supply and signal leads from the connector in the cell wall are directly connected to the device

under test, using either a printed circuit board of length suitable for positioning the device under test in the allowed working region of the TEM cell, or a set of leads secured to a rigid support (see [Figure 3](#) and [Figure 4](#)). The printed circuit board or supported wiring harness between the connector and the device under test will yield reproducible measurement results if the position of the leads and the device under test in the TEM cell are fixed.

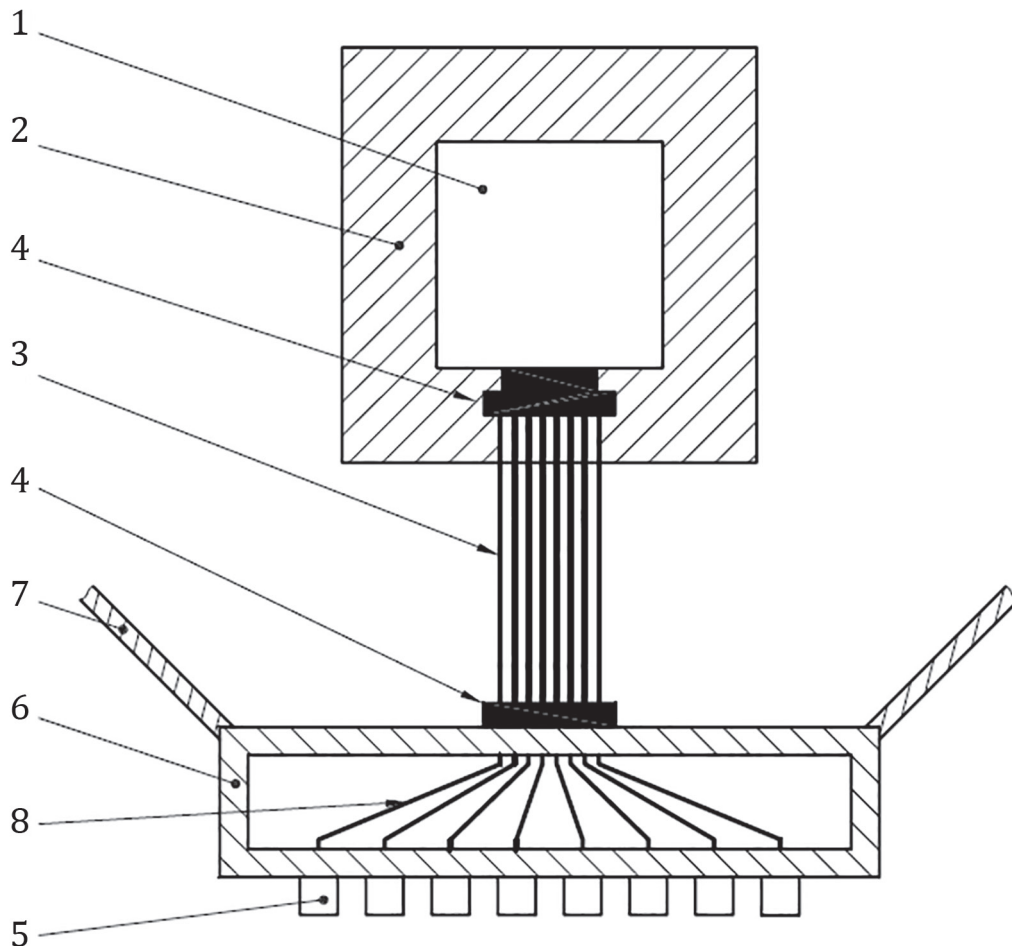

Key

- 1 device under test
- 2 dielectric support (relative permittivity $\epsilon_r \leq 1,4$)
- 3 printed circuit board or wiring harness
- 4 connector
- 5 coaxial connectors
- 6 connector panel
- 7 TEM cell wall
- 8 cables

NOTE RF filters can be connected to the coaxial connectors in the connector panel or directly to the connector in the TEM cell wall.

Figure 4 — Example test set-up — Major field coupling to wiring harness (top view)

5.3.3 Exposure of device under test alone (for major field coupling to that device)

The height of the dielectric support is $b/6$ mm (see [Figure 5](#)). In order to obtain reproducible measurement results, the device under test shall be placed in the same position in the TEM cell for each measurement.

Dimensions in millimetres

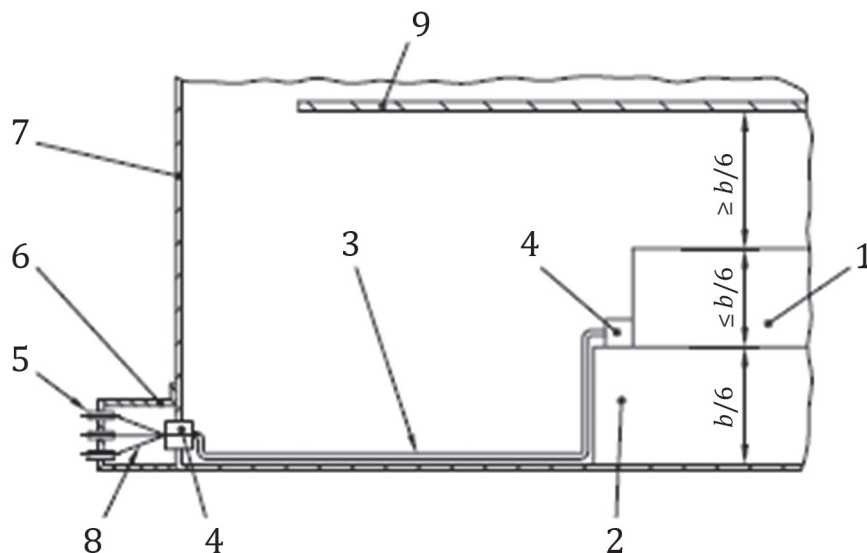

Key

- 1 device under test
- 2 dielectric support (relative permittivity $\epsilon_r \leq 1,4$)
- 3 shielded wiring harness
- 4 connector
- 5 coaxial connectors
- 6 connector panel
- 7 TEM cell wall
- 8 cables
- 9 septum
- b TEM cell height (see [Annex A](#))

Figure 5 — Example test set-up — Major field coupling to device under test (side view)

The connector panel should be attached to the TEM cell. The arrangement and nature of supply and signal leads shall be chosen in order to minimize the coupling on these leads, which shall be secured on the floor of the TEM cell and shielded between the connector in the cell wall and the device under test. This can be done by using metal tape with conductive adhesive to cover the leads on the floor of the TEM cell.

The shield shall be in electrical contact with the cell floor, but shall not be in contact with the case of the device under test.

6 Test procedure

6.1 Test plan

Prior to performing the test, a test plan shall be generated and which shall cover the following:

- frequency range;
- modulation;
- test set-up to be used ([5.3.2](#) or [5.3.3](#) or [Annex D](#));
- device under test mode of operation;
- device under test acceptance criteria;
- definition of test severity levels;
- test signal quality;
- use of net or output power measurements;
- device under test monitoring conditions;
- device under test orientation;
- test report content (see [6.3](#));
- any special instructions and changes from the standard test.

Each device under test shall be tested under the most significant situations, i.e. at least in stand-by mode and in a mode where all the actuators can be excited.

6.2 Test method

6.2.1 General

IMPORTANT — The appropriate guidelines (national regulation, ICNIRP,^{[2][3]} etc.) shall be followed for the protection of the test personnel.

6.2.2 Test level setting

Prior to applying the test field intensity to the DUT and harness, a test field intensity calibration shall be performed at all test frequencies with an empty TEM cell. This will determine the test forward power levels P_{forward} (test) to be used during the DUT test.

The doors of the TEM cell shall be closed at all times during the measurement.

Unused connectors shall be shielded, so that they do not emit radiation.

At each test frequency with a CW RF signal:

- calculate the net power required to achieve the test electric field intensity using [Formula \(1\)](#);
- apply a given forward power (see [Figure 2](#));
- record the reflected power and calculate the corresponding net power;
- adjust the forward power level until the net power to obtain the required test field intensity is achieved and record this test forward power level as P_{forward} (test).

$$E = \sqrt{\frac{Z * P_{\text{net}}}{d}} \quad (1)$$

where

- E is the value of the electric field in volts per metre;
- Z is the characteristic impedance of the TEM cell in ohms (typically 50 Ω);
- P_{net} is the net input power ($P_{\text{net}} = P_{\text{forward}} - P_{\text{reflected}}$), in watts;
- d is the distance, in metres, between the floor and the TEM cell septum ($b/2$ in [Figure A.1](#)).

NOTE The theoretical or supplier data characteristic impedance of the TEM cell can be used in [Formula \(1\)](#).

The test forward power level established during the empty TEM cell field calibration (at the required test field intensity) will be the levelling parameter used during the DUT test. The test power required to achieve the test field intensity level shall be maintained at 0/+1 dB of P_{forward} (test) during the DUT test.

An electrically small field-measuring device may be used to verify the calculated calibration curve for the field in the uniform field region.

6.2.3 DUT test

Place the DUT and harness inside the TEM cell as shown in [Figure 3](#), [Figure 5](#) or [Figure D.1](#) and [Figure D.2](#), depending upon what type of major field coupling (harness or DUT) is desired.

The conductor on the printed circuit board shall be designed to handle the load current. See [Annex D](#) for a test setup without low pass filters.

The doors of the TEM cell shall be closed at all times during the measurement.

Unused connectors shall be shielded, so that they do not emit radiation.

Wherever possible, use the actual vehicle loads, sensors and actuators.

Do not ground the device under test to the TEM cell floor unless it is intended that the actual vehicle configuration be simulated.

Care should be taken not to create ground loops.

The test on the DUT and wiring harness shall be performed using the test level forward power, P_{test} , established during the test field calibration of [6.2.2](#).

For AM signals, the peak power conservation principal as defined in ISO 11542-1 shall be used.

Apply the predetermined test field intensity to the DUT at each frequency while monitoring the DUT for any deviations in operation. If any responses occur, document the frequency where the deviation occurs. A response threshold amplitude measurement should be made at each responding frequency to assist with the evaluation of the test results and DUT performance.

6.3 Test report

As required by the test plan, a test report shall be submitted detailing the following information:

- the test equipment;
- the systems tested;
- the frequencies;

- the power levels;
- the test modulation;
- the major field coupling method used (DUT and/or harness);
- the system interactions;
- other relevant information regarding the test.

Annex A (informative)

TEM cell dimensions

The dimensions of a typical TEM cell are shown in [Figure A.1](#) and given in [Table A.1](#).

Dimensions in millimetres

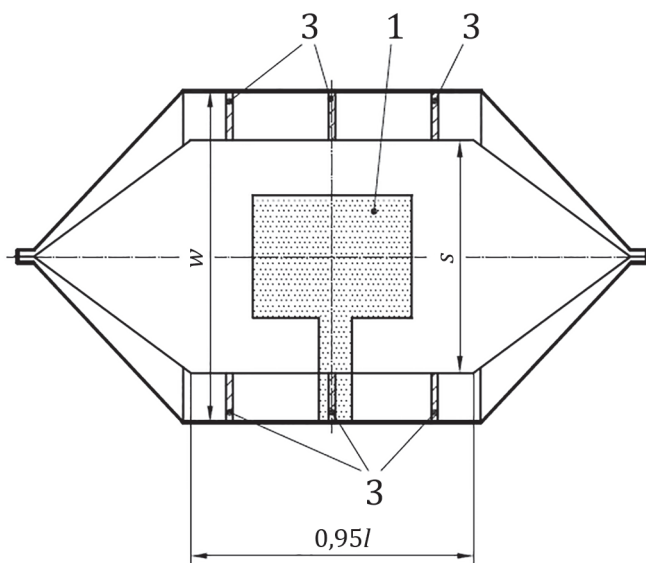

a) Horizontal section view through septum

Figure A.1 (continued)

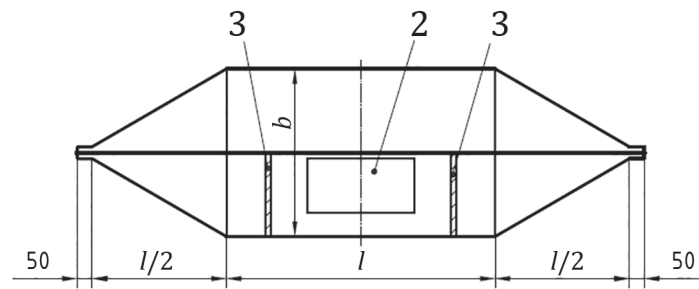

b) Vertical section view

Key

- 1 allowed working region: $0,33w$; $0,60l$
- 2 access door
- 3 dielectric supports

Figure A.1 — TEM cell

Table A.1 — Typical TEM cell dimensions

Upper frequency MHz	Cell form factor		TEM cell height	Septum width
	w/b	l/w	b m	s m
100	1,00	1,00	1,20	1,00
Typical for automotive component testing:				
200	1,69	0,66	0,56	0,70
	1,00	1,00	0,60	0,50
300	1,67	1,00	0,30	0,36
500	1,50	1,00	0,20	0,23

Annex B (informative)

Calculations and measurements of TEM-cell frequency range

B.1 General

The useful frequency range for each TEM cell and its test set-up can be determined by one of two methods, using, for example, a network analyser.

B.2 Method 1

Verify that, for the whole useful frequency range at both inputs (of the empty TEM cell), the following requirements are met:

$$r = \sqrt{\frac{P_{\text{reflected}}}{P_{\text{forward}}}} \leq 0,15 \text{ or voltage standing wave ratio, } V_{\text{SWR}} = \frac{1+r}{1-r} \leq 1,35 \quad (\text{B.1})$$

where

r is the absolute value of the reflection coefficient;

$P_{\text{reflected}}$ is the reflected power;

P_{forward} is the forward power.

B.3 Method 2

Before testing the operative device under test, determine the TEM cell's resonances with the installed test set-up and device under test (without electrical connection). In this case, the TEM cell transmission loss in the useful frequency range shall be:

$$a_{\text{t loss}} = \left| 10 \log \left(\frac{P_{\text{reflected}} + P_{\text{output}}}{P_{\text{reflected}} + P_{\text{forward}}} \right) \right| \leq 1 \text{ dB} \quad (\text{B.2})$$

$$a_{\text{t loss}} = \left| 10 \log \left(\frac{P_{\text{output}}}{P_{\text{forward}} - P_{\text{reflected}}} \right) \right| \leq 1 \text{ dB}$$

where

$a_{\text{t loss}}$ is the TEM cell transmission loss;

$P_{\text{reflected}}$ is the reflected power;

P_{forward} is the forward power;

P_{output} is the power at the TEM cell output.

Measurements and results at frequencies at which the requirements [[Formula \(B.1\)](#) or [Formula \(B.2\)](#)] are not met shall be disregarded, but shall be noted in the test report.

NOTE 1 A TEM cell impedance that does not equal 50 Ω, resulting in an r not equal to zero, leads to a variation of the field strength along the TEM cell longitudinal direction. Such variations can be measured over the whole useful frequency range in the empty TEM cell. The relative field strength non-uniformity ($\Delta\bar{E}$) in the longitudinal direction of the TEM cell can be calculated with [Formula \(B.3\)](#):

$$\Delta\bar{E} = \frac{E_{\max} - E_{\min}}{E_0} \approx 2r \quad (\text{B.3})$$

(typical: $\Delta\bar{E} = 0,3$ for $r = 0,15$)

where

E_0 is the uniform field strength (without any reflection);

E_{\max} is the maximum value of a non-uniform field strength;

E_{\min} is the minimum value of a non-uniform field strength.

NOTE 2 Measurements at the TEM cell resonance frequencies are not allowed, because there is no field uniformity and no TEM mode (e.g. transmission line coupling instead of radiated coupling).

Annex C (informative)

Installation of external components and low pass filter design

C.1 Connector panel

The wiring in the connector panel between connector (4) and the coaxial connectors (5) shown in [Figure 3](#) should be done with 50 Ω coaxial cable to transfer the 50 Ω RF-impedance from the low pass filters attached to the coaxial connectors in the connector panel to the connector in the TEM cell wall.

C.2 External components and low pass filter

External components such as sensors, power supply and actuators should be connected to the filter at the connector panel.

All power and signal leads should be connected via a low pass filter (see [Figure C.1](#)) at the connector panel to the peripheral, to the directly connected parts at the panel or to the vehicle. This minimizes influences from the external connection, such as type and length of leads and lead impedances (peripheral, if possible with original sensors and loads), and unwanted radio frequency (RF) emissions into, or out of, the TEM cell.

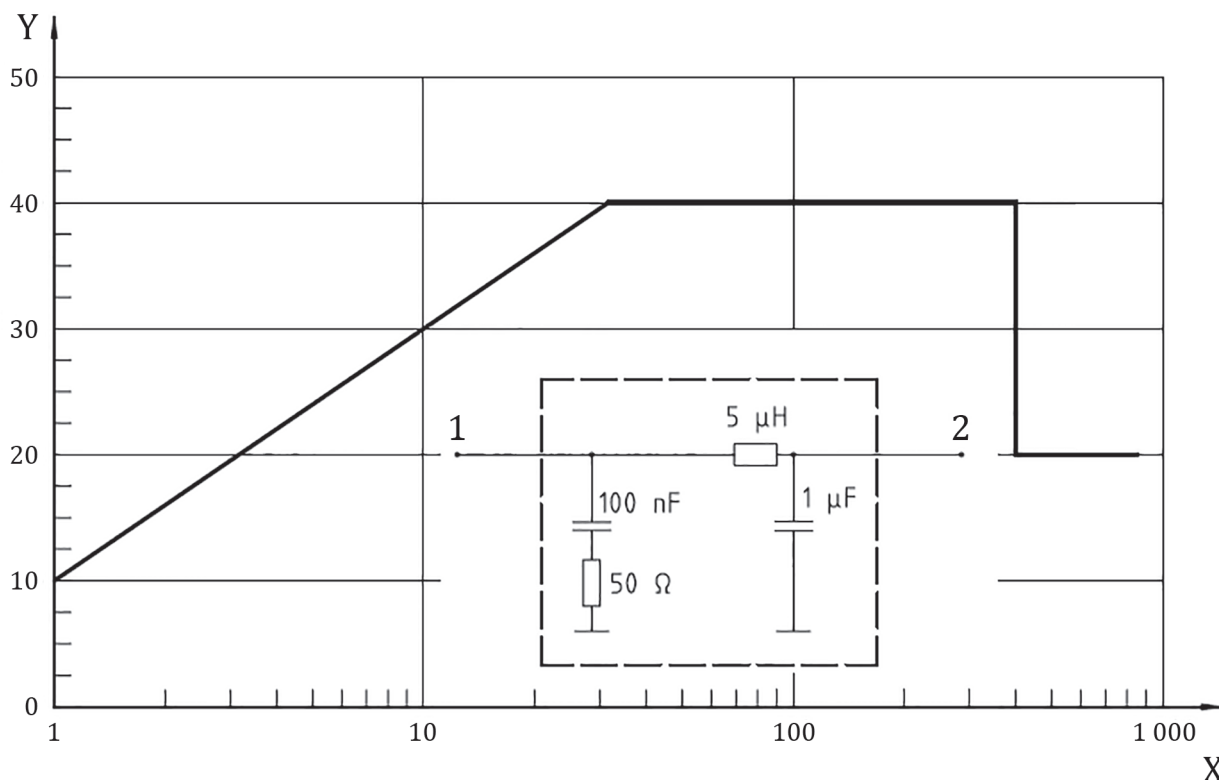

Key

- 1 device under test (DUT) port
- 2 supply port
- X frequency, MHz
- Y minimum attenuation, dB

Figure C.1 — Minimum attenuation and frequency response of the low pass filter with schematic circuit diagram (artificial network)

In [Figure C.1](#), the low pass filter's minimum attenuation from 1 MHz to 800 MHz is shown. For leads with wanted RF signals in the TEM cell useful frequency range, the low pass filter shall be designed in such a way that this minimum attenuation is only effective outside the RF bandwidth of the device under test.

The low pass filter should be designed so that its impedance (from the side of the device under test) does not change the electric data of the input and output of the device under test. Above the useful frequency range of the TEM cell, the impedance of the low pass filter shall be 50 Ω.

NOTE The transfer function is measured between the TEM cell input and the connector panel referenced to a 50 W impedance.

C.3 Design rules for the low pass filter

C.3.1 General

The minimum attenuation and frequency response of the low pass filter is as shown in [Figure C.1](#). It is necessary to terminate the device under test at the TEM cell wall with a well-designed low pass RF filter in order to

- limit the radio frequency emissions into the surrounding space,

- isolate the external peripheral or sensors from the TEM cell RF,
- define the RF load of the printed circuit board output with the result of minimized resonances,
- decouple the TEM cell septum and the circuit board from external loads, and
- ensure that the RF filter does not influence the device under test and its external load in the useful frequency range.

All of the above can be measured and guaranteed via the transfer function between connector panel and TEM cell input.

EXAMPLE The transfer function is the same for connectors terminated by a short circuit and open circuit if the RF filter is used. If the transfer function is measured without using the RF filter, the results differ by up to 30 dB.

It is difficult to define a schematic circuit diagram for the low pass filter because its design is highly dependent on the positioning of the filter elements. It is therefore important to define the three ranges of filter responses versus frequency, as follows.

C.3.2 Lower cut-off frequency

It is not necessary to define the attenuation from DC to 0,01 MHz because TEM cell automotive immunity measurements normally start at 0,01 MHz.

C.3.3 Useful frequency range

The necessary attenuation, a_D , of the RF filter in the useful frequency range of the TEM cell can be calculated with [Formula \(C.1\)](#):

$$a_D \geq 10 \times \log \frac{P_{RF,max}}{P_{E,max} \times a_{C,TEM} \times n_{max}} \approx 33 \text{ dB} \quad (\text{C.1})$$

where

$P_{RF,max}$ is the maximum RF power outside the TEM cell, <0,1 W;

$P_{E,max}$ is the TEM cell maximum power input, 200 W;

$a_{C,TEM}$ is the coupling factor of the TEM cell, 0,01;

n_{max} is the number of connected leads, 100.

Since the coupling factor of the TEM cell decreases strongly for frequencies below 30 MHz, the minimum attenuation can be lowered, as shown in [Figure C.1](#).

C.3.4 Upper cut-off frequency

Above the TEM cell cut-off frequency, only harmonics of the broadband amplifier with nominal 20 dB harmonic attenuation occur, so that a reduced filter attenuation of 20 dB is sufficient.

Since the impedance of the harness of the device under test outside the TEM cell lies between 20 Ω and 200 Ω , it is recommended that the high frequency impedance from the DUT side of the RF filter be 50 Ω . This compromise will allow the RF filter to be the same as the artificial network defined in CISPR 25[1] (100 nF and 50 Ω).

Annex D (informative)

Test setup without low pass filters

D.1 General

In some cases, the number of wiring harness of DUT is huge. So, it becomes very hard to use low pass filters.

This annex presents a test set-up without low pass filters. TEM cell shall be located inside a shielded enclosure.

D.2 Test set-up

The wiring harnesses from DUT are passed through either the wall or the floor (ceiling) of the TEM cell depending on the TEM cell structure. [Figure D.1](#) and [Figure D.2](#) show the example setup of each test method.

The position of the DUT connector is centre of TEM cell (see [Figure D.1](#) with horizontal harness and [Figure D.2](#) with vertical harness). In order to obtain reproducible measurement results, the DUT shall be placed in the same position in the TEM cell for each measurement.

The clearance between the wire harness and the through-hole shall be between 5 mm and $b/6$. The ferrite installed to the wiring harness outside of the TEM cell may reduce the RF radiation from wiring harness. The networks (AN, AMN and AAN) shall be used at the correct position and mounted directly on the shielded enclosure (wall or floor). The detailed setup shall be described in the test plan.

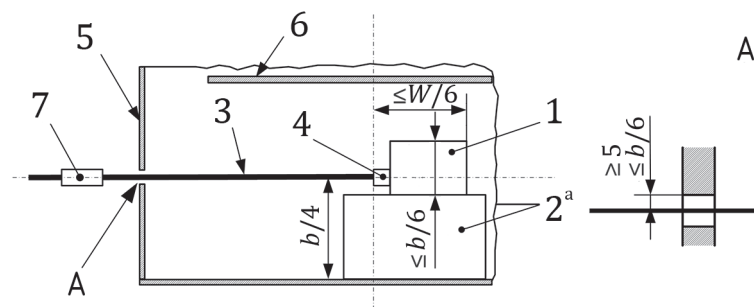

Key

- 1 DUT
- 2 dielectric support (relative permittivity $\epsilon_r \leq 1,4$)
- 3 wiring harness (unshielded)
- 4 connector
- 5 TEM cell wall
- 6 septum
- 7 ferrite (optional)
- b TEM cell height
- W TEM cell width
- ^a The height of insulating support should be adapted to ensure that the harness is horizontal.

Figure D.1 — Example test set-up — Wire harness location: horizontal (side view)

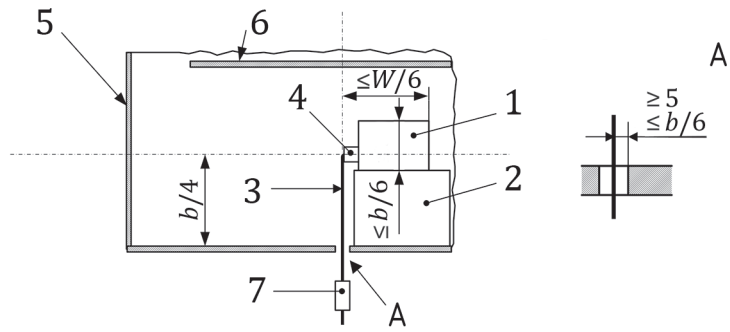

Key

- 1 DUT
- 2 dielectric support (relative permittivity $\epsilon_r \leq 1,4$)
- 3 wiring harness (unshielded)
- 4 Connector
- 5 TEM cell wall
- 6 Septum
- 7 ferrite (optional)
- b TEM cell height
- W TEM cell width

Figure D.2 — Example test set-up — Wire harness location: vertical (side view)

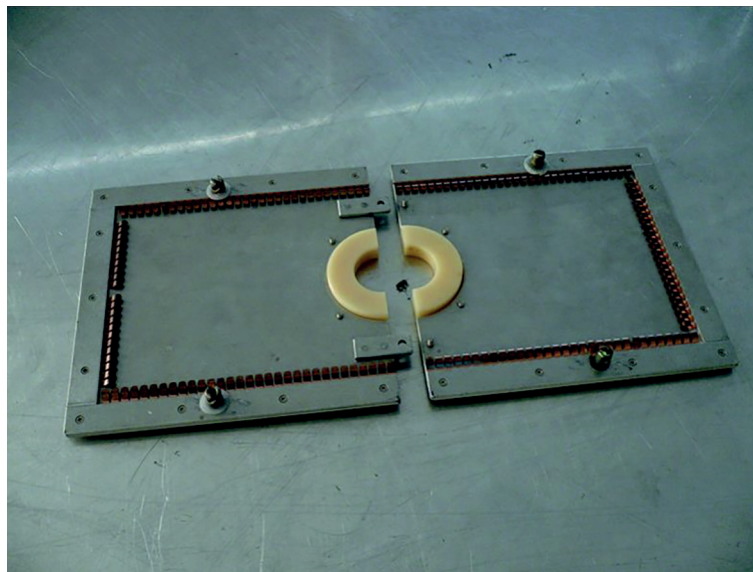

Figure D.3 — Example of through-hole panel

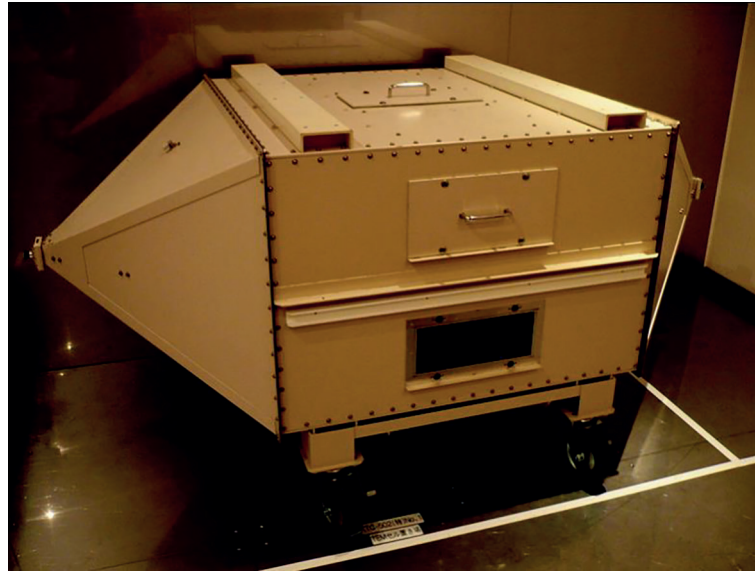

Figure D.4 — Example of TEM cell before attaching a through-hole panel

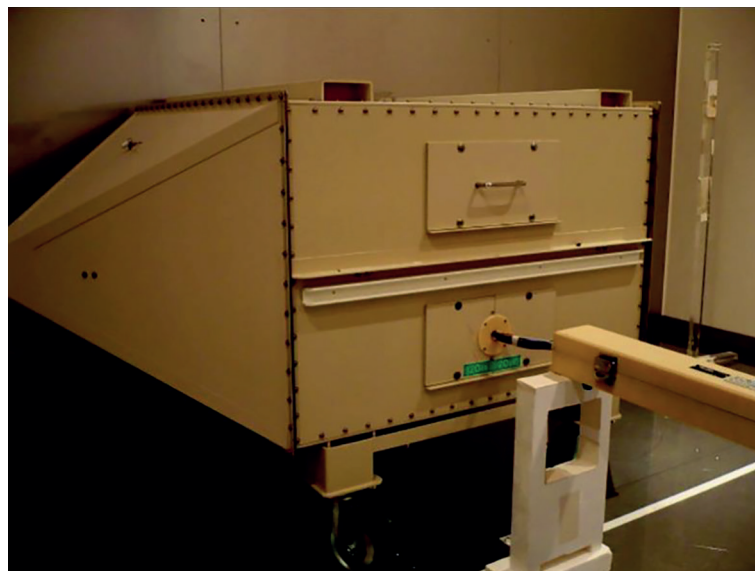

Figure D.5 — Example of test setup with a through-hole panel

Annex E (informative)

Function performance status classification (FPSC) and test severity levels

E.1 General

This annex gives examples of test severity levels which should be used in line with the principle of functional performance status classification (FPSC) described in ISO 11452-1.

E.2 Classification of test severity levels

The suggested minimum and maximum severity levels are given in [Table E.1](#).

Table E.1 — Examples of test severity levels (internal field)

Frequency band MHz	Test level I V/m	Test level II V/m	Test level III V/m	Test level IV V/m	Test level V V/m
0,01 to 10	50	80	150	200	Specific value agreed between the users of this document
10 to 30	50	80	150	180	
30 to 80	60	100	120	180	
80 to 200	60	100	120	200	

E.3 Example of FPSC application using test severity levels

Each DUT and its function(s) need to be evaluated prior to test. The category of the DUT function(s), test severity level(s) and response criteria should then be agreed upon between the supplier and the vehicle manufacturer. This information should be documented in the test plan and used for the determination of DUT acceptance upon completion of the testing and evaluation of the test results.

An example of severity levels is given in [Table E.2](#).

Table E.2 — Examples of test severity levels

Test severity level	DUT function Category 1	DUT function Category 2	DUT function Category 3	DUT function Category 4
L _{4i}	Level IV	—	—	—
L _{3i}	Level III	Level IV	—	—
L _{2i}	Level II	Level III	Level IV	—
L _{1i}	Level I	Level II	Level III	Level IV

Bibliography

- [1] CISPR 25, *Limits and methods of measurement of radio disturbance characteristics for the protection of receivers used on board vehicle*
- [2] Guidelines for Limiting Exposure to Time-Varying Electric, Magnetic, and Electromagnetic Fields (up to 300 GHz). *Health Phys.* 1998, **74** (4) pp. 494–522
- [3] Guidelines for limiting exposure to time-varying electric and magnetic fields (1 Hz to 100 kHz). *Health Physics.* 2010, 99 (6) pp. 818-836

British Standards Institution (BSI)

BSI is the national body responsible for preparing British Standards and other standards-related publications, information and services.

BSI is incorporated by Royal Charter. British Standards and other standardization products are published by BSI Standards Limited.

About us

We bring together business, industry, government, consumers, innovators and others to shape their combined experience and expertise into standards-based solutions.

The knowledge embodied in our standards has been carefully assembled in a dependable format and refined through our open consultation process. Organizations of all sizes and across all sectors choose standards to help them achieve their goals.

Information on standards

We can provide you with the knowledge that your organization needs to succeed. Find out more about British Standards by visiting our website at bsigroup.com/standards or contacting our Customer Services team or Knowledge Centre.

Buying standards

You can buy and download PDF versions of BSI publications, including British and adopted European and international standards, through our website at bsigroup.com/shop, where hard copies can also be purchased.

If you need international and foreign standards from other Standards Development Organizations, hard copies can be ordered from our Customer Services team.

Copyright in BSI publications

All the content in BSI publications, including British Standards, is the property of and copyrighted by BSI or some person or entity that owns copyright in the information used (such as the international standardization bodies) and has formally licensed such information to BSI for commercial publication and use.

Save for the provisions below, you may not transfer, share or disseminate any portion of the standard to any other person. You may not adapt, distribute, commercially exploit, or publicly display the standard or any portion thereof in any manner whatsoever without BSI's prior written consent.

Storing and using standards

Standards purchased in soft copy format:

- A British Standard purchased in soft copy format is licensed to a sole named user for personal or internal company use only.
- The standard may be stored on more than 1 device provided that it is accessible by the sole named user only and that only 1 copy is accessed at any one time.
- A single paper copy may be printed for personal or internal company use only.

Standards purchased in hard copy format:

- A British Standard purchased in hard copy format is for personal or internal company use only.
- It may not be further reproduced – in any format – to create an additional copy. This includes scanning of the document.

If you need more than 1 copy of the document, or if you wish to share the document on an internal network, you can save money by choosing a subscription product (see 'Subscriptions').

Reproducing extracts

For permission to reproduce content from BSI publications contact the BSI Copyright & Licensing team.

Subscriptions

Our range of subscription services are designed to make using standards easier for you. For further information on our subscription products go to bsigroup.com/subscriptions.

With **British Standards Online (BSOL)** you'll have instant access to over 55,000 British and adopted European and international standards from your desktop. It's available 24/7 and is refreshed daily so you'll always be up to date.

You can keep in touch with standards developments and receive substantial discounts on the purchase price of standards, both in single copy and subscription format, by becoming a **BSI Subscribing Member**.

PLUS is an updating service exclusive to BSI Subscribing Members. You will automatically receive the latest hard copy of your standards when they're revised or replaced.

To find out more about becoming a BSI Subscribing Member and the benefits of membership, please visit bsigroup.com/shop.

With a **Multi-User Network Licence (MUNL)** you are able to host standards publications on your intranet. Licences can cover as few or as many users as you wish. With updates supplied as soon as they're available, you can be sure your documentation is current. For further information, email subscriptions@bsigroup.com.

Revisions

Our British Standards and other publications are updated by amendment or revision.

We continually improve the quality of our products and services to benefit your business. If you find an inaccuracy or ambiguity within a British Standard or other BSI publication please inform the Knowledge Centre.

Useful Contacts

Customer Services

Tel: +44 345 086 9001

Email (orders): orders@bsigroup.com

Email (enquiries): cservices@bsigroup.com

Subscriptions

Tel: +44 345 086 9001

Email: subscriptions@bsigroup.com

Knowledge Centre

Tel: +44 20 8996 7004

Email: knowledgecentre@bsigroup.com

Copyright & Licensing

Tel: +44 20 8996 7070

Email: copyright@bsigroup.com

BSI Group Headquarters

389 Chiswick High Road London W4 4AL UK