

BS ISO 11451-2:2015



BSI Standards Publication

Road vehicles — Vehicle test methods for electrical disturbances from narrowband radiated electromagnetic energy

Part 2: Off-vehicle radiation sources

bsi.

...making excellence a habit.™

National foreword

This British Standard is the UK implementation of ISO 11451-2:2015.

The UK participation in its preparation was entrusted to Technical Committee AUE/16, Data Communication (Road Vehicles).

A list of organizations represented on this committee can be obtained on request to its secretary.

This publication does not purport to include all the necessary provisions of a contract. Users are responsible for its correct application.

© The British Standards Institution 2015. Published by BSI Standards Limited 2015

ISBN 978 0 580 78595 5

ICS 33.100.20; 43.040.10

Compliance with a British Standard cannot confer immunity from legal obligations.

This British Standard was published under the authority of the Standards Policy and Strategy Committee on 30 June 2015.

Amendments issued since publication

Date	Text affected
------	---------------

**Road vehicles — Vehicle test methods
for electrical disturbances from
narrowband radiated electromagnetic
energy —**

**Part 2:
Off-vehicle radiation sources**

*Véhicules routiers — Méthodes d'essai d'un véhicule soumis
à des perturbations électriques par rayonnement d'énergie
électromagnétique en bande étroite —*

Partie 2: Sources de rayonnement hors du véhicule





COPYRIGHT PROTECTED DOCUMENT

© ISO 2015, Published in Switzerland

All rights reserved. Unless otherwise specified, no part of this publication may be reproduced or utilized otherwise in any form or by any means, electronic or mechanical, including photocopying, or posting on the internet or an intranet, without prior written permission. Permission can be requested from either ISO at the address below or ISO's member body in the country of the requester.

ISO copyright office
Ch. de Blandonnet 8 • CP 401
CH-1214 Vernier, Geneva, Switzerland
Tel. +41 22 749 01 11
Fax +41 22 749 09 47
copyright@iso.org
www.iso.org

Contents

Page

Foreword	iv
1 Scope	1
2 Normative references	1
3 Terms and definitions	1
4 Test conditions	1
5 Test location	2
6 Test instrumentation	4
6.1 Field generating device.....	4
6.2 Field probes.....	5
6.3 Stimulation and monitoring of the device under test (DUT).....	5
7 Test set-up	5
7.1 Vehicle placement.....	6
7.2 Field generating device location (relative to vehicle and shielded enclosure).....	6
7.2.1 Antenna constraints.....	6
7.2.2 TLS constraints.....	6
7.3 Vehicle test configurations.....	6
7.3.1 Vehicle not connected to the power grid.....	6
7.3.2 Vehicle in charging mode connected to the power grid.....	7
7.3.3 Vehicle in charging mode through wireless power transmission (WPT).....	15
8 Test procedure	17
8.1 Test plan.....	18
8.2 Test method.....	18
8.2.1 Field calibration.....	18
8.3 Test report.....	24
Annex A (informative) Function performance status classification	25

Foreword

ISO (the International Organization for Standardization) is a worldwide federation of national standards bodies (ISO member bodies). The work of preparing International Standards is normally carried out through ISO technical committees. Each member body interested in a subject for which a technical committee has been established has the right to be represented on that committee. International organizations, governmental and non-governmental, in liaison with ISO, also take part in the work. ISO collaborates closely with the International Electrotechnical Commission (IEC) on all matters of electrotechnical standardization.

The procedures used to develop this document and those intended for its further maintenance are described in the ISO/IEC Directives, Part 1. In particular the different approval criteria needed for the different types of ISO documents should be noted. This document was drafted in accordance with the editorial rules of the ISO/IEC Directives, Part 2 (see www.iso.org/directives).

Attention is drawn to the possibility that some of the elements of this document may be the subject of patent rights. ISO shall not be held responsible for identifying any or all such patent rights. Details of any patent rights identified during the development of the document will be in the Introduction and/or on the ISO list of patent declarations received (see www.iso.org/patents).

Any trade name used in this document is information given for the convenience of users and does not constitute an endorsement.

For an explanation on the meaning of ISO specific terms and expressions related to conformity assessment, as well as information about ISO's adherence to the WTO principles in the Technical Barriers to Trade (TBT) see the following URL: [Foreword - Supplementary information](#)

The committee responsible for this document is ISO/TC 22, *Road vehicles*, Subcommittee SC 32, *Electrical and electronic components and general system aspects*.

[Annex A](#) of this part of ISO 11451 is for information only.

This fourth edition cancels and replaces the third edition (ISO 11451-2:2005) which has been technically revised.

ISO 11451 consists of the following parts, under the general title *Road vehicles — Vehicle test methods for electrical disturbances from narrowband radiated electromagnetic energy*:

- *Part 1: General principles and terminology*
- *Part 2: Off-vehicle radiation sources*
- *Part 3: On-board transmitter simulation*
- *Part 4: Bulk current injection (BCI)*

Road vehicles — Vehicle test methods for electrical disturbances from narrowband radiated electromagnetic energy —

Part 2: Off-vehicle radiation sources

1 Scope

This part of ISO 11451 specifies a method for testing the immunity of passenger cars and commercial vehicles to electrical disturbances from off-vehicle radiation sources, regardless of the vehicle propulsion system (e.g. spark ignition engine, diesel engine, electric motor).

The electromagnetic disturbances considered are limited to narrowband electromagnetic fields.

While this standard refers specifically to passenger cars and commercial vehicles, generalized as “vehicle(s)”, it can readily be applied to other types of vehicles.

ISO 11451-1 specifies general test conditions, definitions, practical use, and basic principles of the test procedure.

Function performance status classification guidelines for immunity to electromagnetic radiation from an off-vehicle radiation source are given in [Annex A](#).

2 Normative references

The following documents, in whole or in part, are normatively referenced in this document and are indispensable for its application. For dated references, only the edition cited applies. For undated references, the latest edition of the referenced document (including any amendments) applies.

ISO 11451-1, *Road vehicles — Vehicle test methods for electrical disturbances from narrowband radiated electromagnetic energy — Part 1: General principles and terminology*

3 Terms and definitions

For the purposes of this document, the terms and definitions given in ISO 11451-1 apply.

4 Test conditions

The applicable frequency range of this test method is 0,01 MHz to 18 000 MHz. Testing over the full frequency range could require different field-generating devices, but this does not imply that testing of overlapping frequency ranges is required.

The user shall specify the test severity level or levels over the frequency range. Suggested test severity levels are given in [Annex A](#) of this International Standard.

Standard test conditions are given in ISO 11451-1 for the following:

- test temperature;
- supply voltage;

- modulation;
- dwell time;
- frequency step sizes;
- definition of test severity levels;
- test signal quality.

5 Test location

The test should be performed in an absorber-lined shielded enclosure.

The aim of using an absorber-lined shielded enclosure is to create an indoor electromagnetic compatibility testing facility that simulates open field testing.

The size, shape, and construction of the enclosure can vary considerably. Typically, the floor is not covered with absorbing material, but such covering is allowed. Measurements in enclosures with or without floor absorbers can lead to different results. The minimum size of the shielded enclosure is determined by the size of the test region needed, the size of the field generation device or devices, the needed clearances between these and the largest vehicle to be tested, and the characteristics of the absorbing material. To create the test region, the absorber, field generation system and enclosure shape are selected such that the amount of extraneous energy in the test region is reduced to below a minimum value that will give the desired measurement accuracy. The design objective is to reduce the reflected energy in the test region to -10 dB or less over the test frequency range (not applicable to transmission line system (TLS) field generation systems). An example of a rectangular shielded enclosure is shown in [Figure 1](#).

The test may alternatively be performed at an outdoor test site. The test facility shall comply with (national) legal requirements regarding the emission of electromagnetic fields.

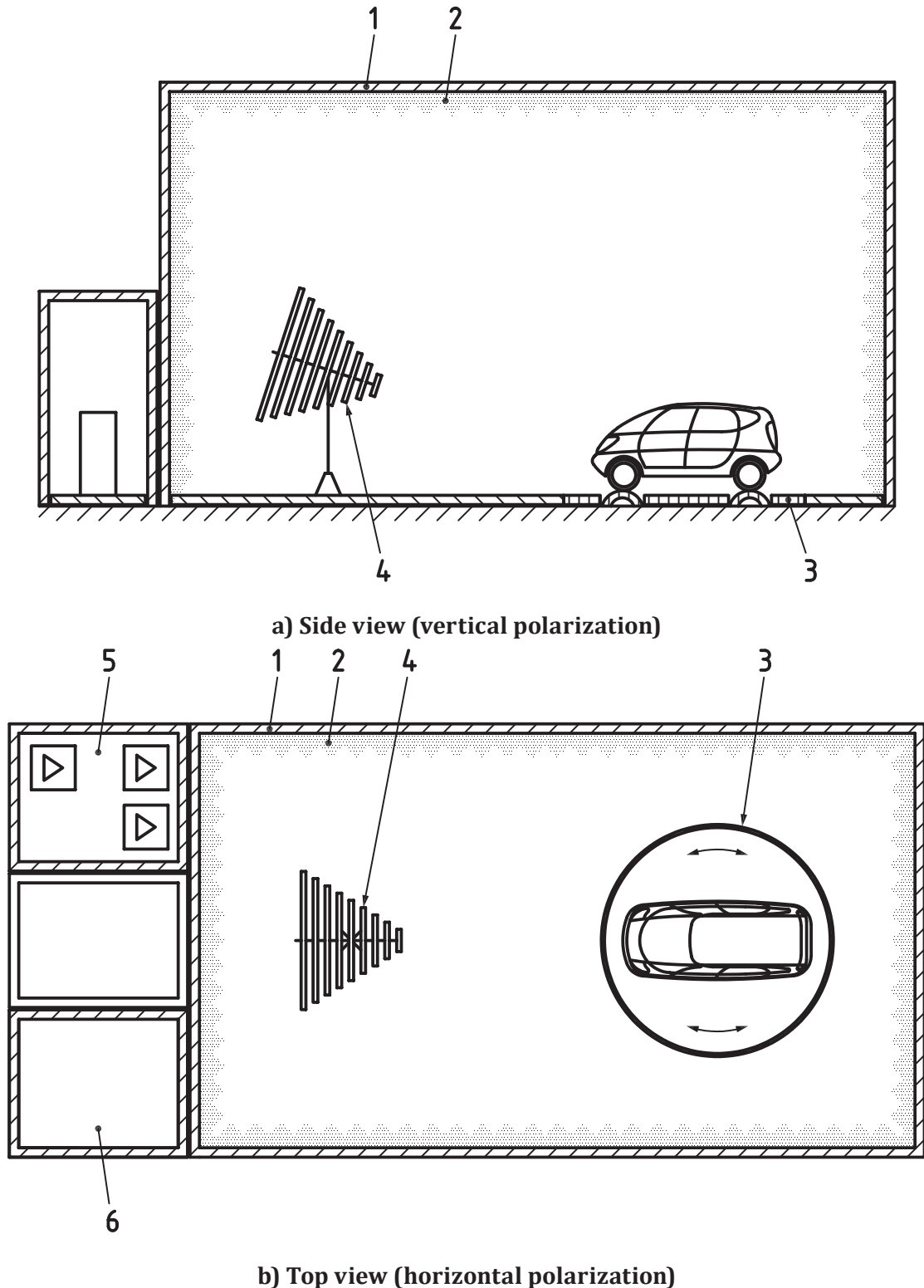

Key

- | | |
|---|------------------|
| 1 absorber-lined shielded enclosure | 4 antenna |
| 2 RF absorber material | 5 amplifier room |
| 3 vehicle dynamometer on turntable ^a | 6 control room |

^a Turntable shown rotatable through $\pm 180^\circ$ with two pairs of variable wheelbase rollers to accommodate all vehicle sizes and functions.

Figure 1 — Example of absorber-lined shielded enclosure

6 Test instrumentation

Testing consists of generating radiated electromagnetic fields using antenna sets with radio frequency (RF) sources capable of producing the desired field strength over the range of test frequencies.

The following test instrumentation is used:

- Field generating device(s): e.g. antenna(s);
- Field probe(s);
- RF signal generator with internal or external modulation capability;
- High power amplifier(s);
- Powermeter (or equivalent measuring instrument) to measure forward power and reflected power.

6.1 Field generating device

The field generating device can be an antenna or a TLS.

The construction and orientation of any field generating device shall be such that the generated field can be polarized in the mode specified in the test plan (see 8.1). An example of a parallel-plate TLS is shown in Figure 2. Multiple antennas, amplifiers and directional couplers could be necessary to cover the complete frequency range.

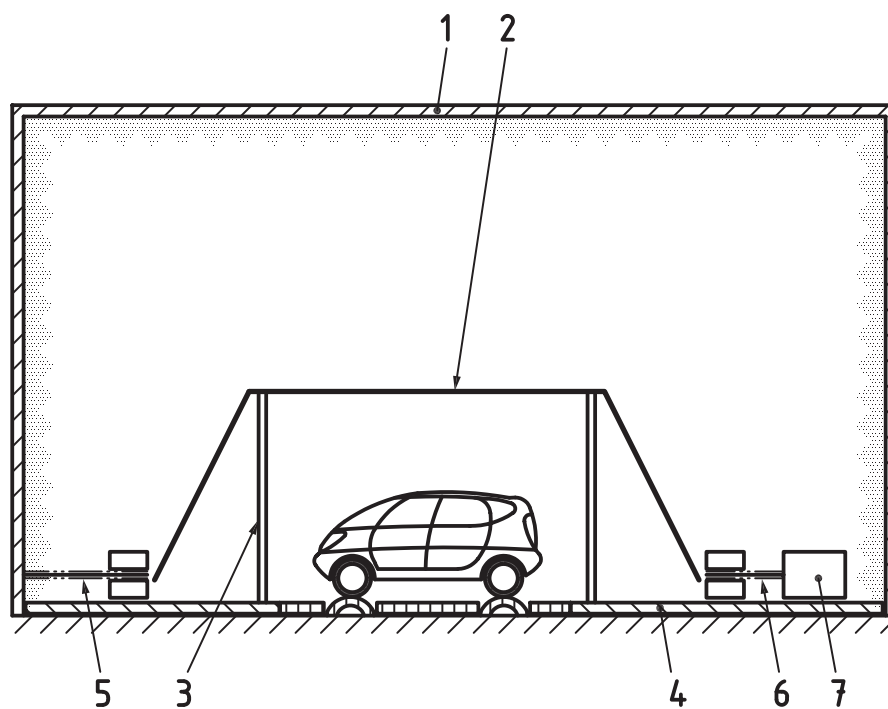

a) Side view

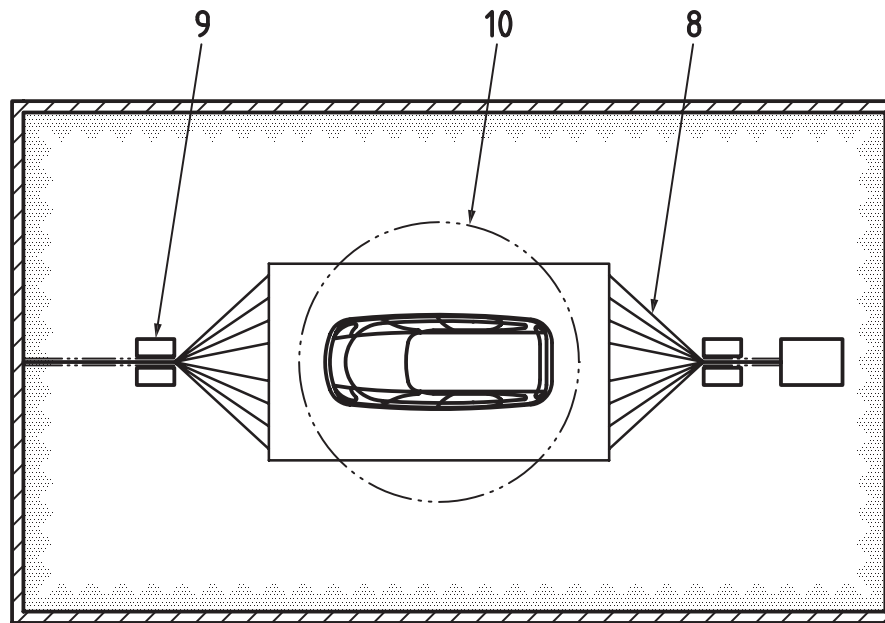

b) Top view

Key

- | | |
|--|---|
| 1 shielded enclosure (absorbers permitted) | 6 coaxial cable |
| 2 conductive plate or set of wires | 7 load |
| 3 non-metallic supports | 8 conductive wires |
| 4 shielded enclosure floor | 9 signal source feed connection |
| 5 signal source feed line (coaxial cable) | 10 turntable (not required for this test) |

Figure 2 — Example of parallel-plate TLS

6.2 Field probes

Field probes shall be electrically small in relation to the wavelength and isotropic. The communication lines from the probes shall be fibre optic links.

6.3 Stimulation and monitoring of the device under test (DUT)

The vehicle shall be operated as required in the test plan by using actuators which have a minimum effect on the electromagnetic characteristics, e.g. plastic blocks on the push-buttons, pneumatic actuators with plastic tubes.

Connections to equipment monitoring electromagnetic interference reactions of the vehicle may be accomplished by using fibre-optics, or high resistance leads. Other type of leads can be used but require extreme care to minimize interactions. The orientation, length, and location of such leads shall be carefully documented to ensure repeatability of test results.

Any electrical connection of monitoring equipment to the vehicle can cause malfunctions of the vehicle. Extreme care shall be taken to avoid such an effect.

7 Test set-up

Three test setups are described:

- one for all types of vehicles when they are not connected to the power mains;

- one for vehicles in charging mode connected to the power grid (with or without communication);
- one for vehicles in charging mode through wireless power transmission (WPT).

7.1 Vehicle placement

The vehicle shall be placed in the test region. The test region can contain a vehicle dynamometer or turntable or both (see [Figure 1](#)).

7.2 Field generating device location (relative to vehicle and shielded enclosure)

The position or positions of the vehicle relative to the antenna or TLS shall be specified in the test plan (see [8.1](#)).

The radiating elements of the field-generating device shall be no closer than 0,5 m to any absorbing material and no closer than 1,5 m to the wall of the shielded enclosure.

7.2.1 Antenna constraints

No part of the radiating antenna shall be closer than 0,5 m to the outer body surface of the vehicle.

The phase centre of the antenna shall be separated by at least 2 m horizontally from the reference point.

No part of an antenna's radiating elements shall be closer than 0,25 m to the floor.

There shall be no absorber material in the direct path between the transmitting antenna and the DUT.

7.2.2 TLS constraints

No part of a TLS, with the exception of the ground plane, shall be closer than 0,5 m to any part of the vehicle. The TLS radiating element or elements shall be separated by at least 1 m vertically from the reference point (see [8.2.1.1](#)).

The TLS shall extend centrally over at least 75 % of the length of the vehicle.

Particular care needs to be taken when testing heavy vehicles such as buses and large trucks. Under certain conditions related to dimensions and frequency, it is possible that close to 100 % of the applied power can be coupled to the vehicle by a directional coupler mechanism. Room resonances can also have a significant effect on the field uniformity, amplitude and direction under the TLS.

7.3 Vehicle test configurations

The configuration of [7.3.1](#) is applicable to whatever the vehicle type (combustion engine, electric, or hybrid propulsion).

The configuration of [7.3.2](#) is applicable only to the electric or hybrid/plugin propelled vehicles when they are in charging mode and connected to the power grid.

The configuration of [7.3.3](#) is applicable only to the electric propelled vehicles when they are in charging mode through wireless power transmission (WPT).

7.3.1 Vehicle not connected to the power grid

An example of a test set-up is shown in [Figure 3](#).

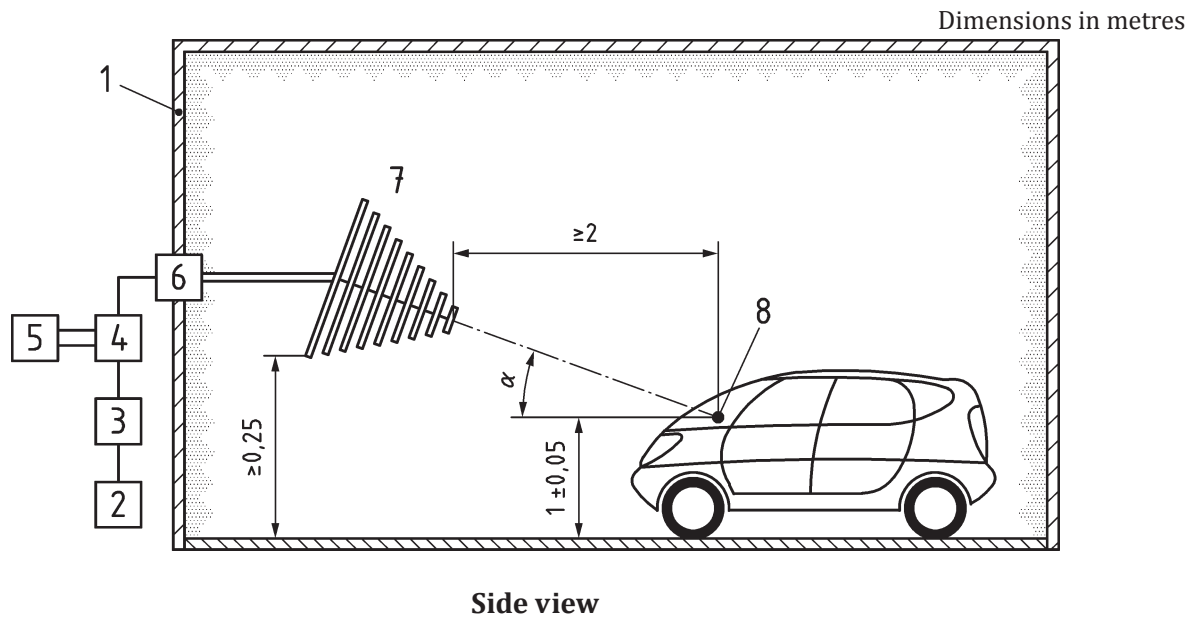

Key

- 1 absorber-lined shielded enclosure
- 2 RF signal generator
- 3 power amplifier
- 4 dual directional coupler
- 5 power meter
- 6 coaxial feed through
- 7 field generating device
- 8 vehicle reference point (see [8.2.1.1.2](#))
- α is the tilt angle of the antenna

Figure 3 — Example of test set-up

7.3.2 Vehicle in charging mode connected to the power grid

The various configurations (a.c. or d.c., with or without communication) are considered in this clause.

7.3.2.1 AC power charging without communication

7.3.2.1.1 Power mains

The power mains socket can be placed anywhere in the test location with the following conditions.

- It shall be placed on the ground plane.
- The length of the harness between the power mains socket and the AMN(s) shall be kept as short as possible.
- The harness shall be placed as close as possible of the ground plane.

Care shall be taken to avoid disturbances to the off-board peripheral equipment.

7.3.2.1.2 Artificial mains network

Power mains shall be applied to the vehicle through 50 μ H/50 Ω artificial mains networks (AMN(s)) as defined in ISO 11451-1, Annex B.

The AMN(s) shall be mounted directly on the ground plane. The grounding connection of the AMN(s)/ AMN(s) shall be bonded to the ground plane with a low inductivity connection.

The measuring port of each AMN shall be terminated with a 50Ω load.

The AMN shall be placed in front, aligned and on the same side of the vehicle power charging plug.

7.3.2.1.3 Power charging cable

The power charging cable shall be placed in a straight line between the AMN(s) and the vehicle charging plug and shall be routed perpendicularly to the vehicle longitudinal axis as shown in [Figures 4](#) and [5](#). The distance between the AMN(s) and the vehicle body should be $0,8 (+0,2/0)$ m.

If the length of the cable is longer than 1 m, the extraneous length shall be “Z-folded” in less than 0,5 m width.

The charging cable at vehicle side shall hang vertically at a distance of $100 (+200/0)$ mm from the vehicle body.

The whole cable shall be placed on a non-conductive, low relative permittivity (dielectric-constant) material ($\epsilon_r \leq 1,4$), at (100 ± 25) mm above the ground plane.

Examples of test set-ups are shown in [Figures 4](#) and [5](#).

Dimensions in metres

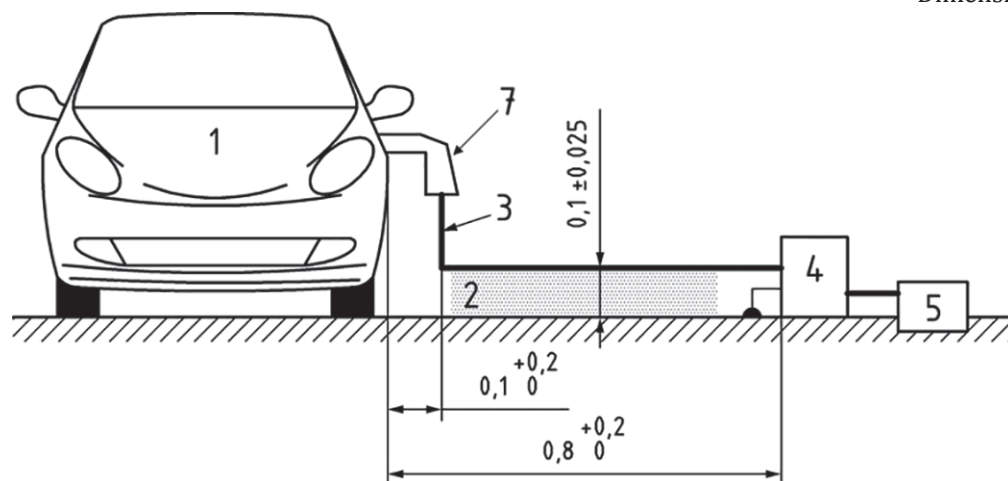

a) Front view

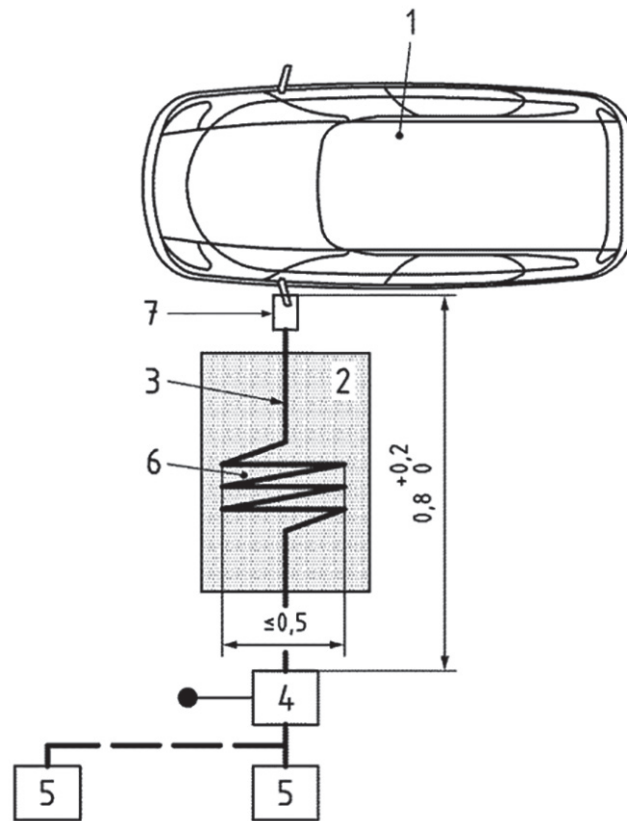

b) Top view

Key

- 1 vehicle under test
- 2 insulating support
- 3 charging cable
- 4 artificial mains network(s) grounded
- 5 power mains socket (see [7.3.2.1.1](#))
- 6 extraneous length Z-folded
- 7 charging cable plug

Figure 4 — Example of test setup for vehicle with plug located on vehicle side (a.c. power charging without communication)

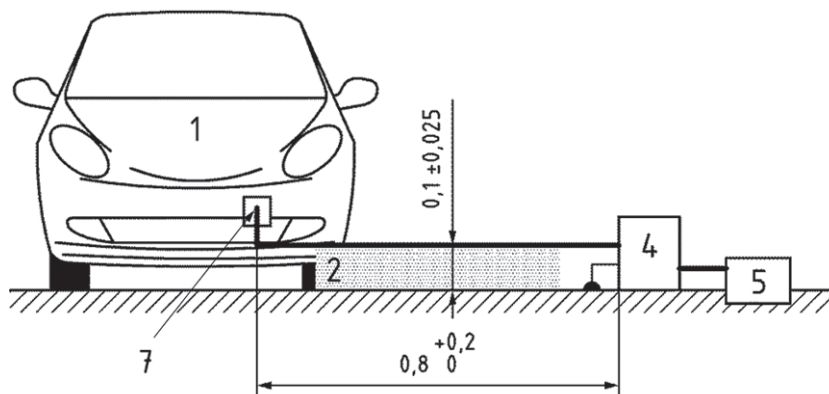

a) Front view

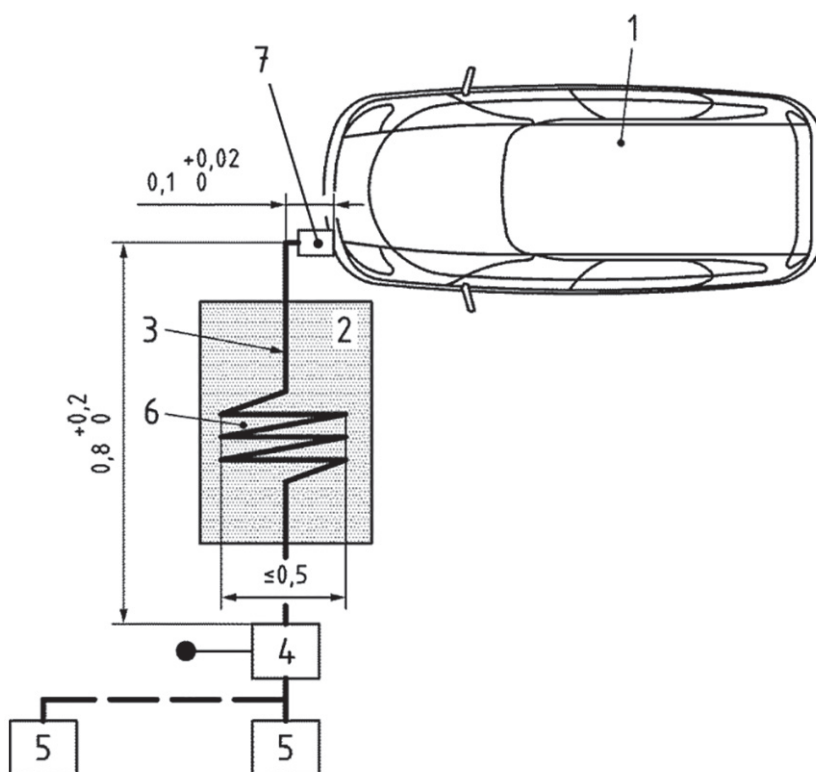

b) Top view

Key

- 1 vehicle under test
- 2 insulating support
- 3 charging cable
- 4 artificial mains network(s) grounded
- 5 power mains socket (see 7.3.2.1.1)
- 6 extraneous length Z-folded
- 7 charging cable plug

Figure 5 — Example of test setup for vehicle with plug located front / rear of vehicle (a.c. power charging without communication)

7.3.2.2 AC or DC power charging with communication

This configuration concerns slow/fast charging mode for a.c. power and fast charging mode for d.c. power.

7.3.2.2.1 Charging station/Power mains

The charging station can be placed either in the test location or outside the test location.

NOTE 1 If the communication between the vehicle and the charging station could be simulated, the charging station can be replaced by the supply from power mains.

In both cases, duplicated power mains and communication lines socket(s) shall be placed in the test location with the following conditions.

- It shall be placed on the ground plane.
- The length of the harness between the power mains / communication lines socket and the HV-AN/AMN/AAN shall be kept as short as possible.
- The harness between the power mains / communication lines socket and the HV-AN/AMN/AAN shall be placed as close as possible of the ground plane.

NOTE 2 The power mains and communication lines socket(s) are to be filtered.

If the charging station is placed inside the test location then harness between charging station and the power mains / communication lines socket shall be placed with the following conditions:

- The harness at charging station side shall hang vertically down to the ground plane.
- The extraneous length shall be placed as close as possible of the ground plane and “Z-folded” if necessary.

Care shall be taken to avoid disturbances to the off-board peripheral equipment.

7.3.2.2.2 Artificial networks

AC Power mains shall be applied to the vehicle through 50 $\mu\text{H}/50 \Omega$ AMN(s) as defined in ISO 11451-1, Annex B.

DC Power mains shall be applied to the vehicle through 5 $\mu\text{H}/50 \Omega$ HV-AN(s) as defined in ISO 11451-1, Annex B.

The HV-AN/AMN shall be mounted directly on the ground plane. The grounding connection of the HV-AN/AMN shall be bonded to the ground plane with a low inductivity connection.

The measuring port of each HV-AN/AMN shall be terminated with a 50 Ω load.

The HV-AN/AMN shall be placed in front, aligned and on the same side of the vehicle power charging plug.

7.3.2.2.3 Asymmetric Artificial Network

Communication lines may optionally be applied to the vehicle through the AAN(s) as defined in ISO 11451-1, Annex B.

The AAN(s) shall be mounted directly on the ground plane. The grounding connection of the AAN(s) shall be bonded to the ground plane with a low inductivity connection.

The measuring port of each AAN shall be terminated with a 50 Ω load.

The AAN shall be placed in front, aligned and on the same side of the vehicle power charging plug.

7.3.2.2.4 Power charging/communication cable

The power charging/communication cable shall be placed in a straight line between the HV-AN(s)/AMN(s)/AAN(s) and the vehicle charging plug and shall be routed perpendicularly to the vehicle longitudinal axis as shown in [Figures 6](#) and [7](#). The distance between the AMN(s) and the vehicle body should be 0,8 (+0,2/-0) m.

If the length of the cable is longer than 1 m, the extraneous length shall be “Z-folded” in less than 0,5 m width.

The charging/communication cable at vehicle side shall hang vertically at a distance of 100 (+200/-0) mm from the vehicle body.

The whole cable shall be placed on a non-conductive, low relative permittivity (dielectric-constant) material ($\epsilon_r \leq 1,4$), at (100 ± 25) mm above the ground plane.

NOTE In case of other lines between vehicle and charging station which are used neither for charging nor for communication (e.g. a 12V line), the loading conditions for these lines should be defined in the test plan.

Examples of test set-ups are shown in [Figures 6](#) and [7](#).

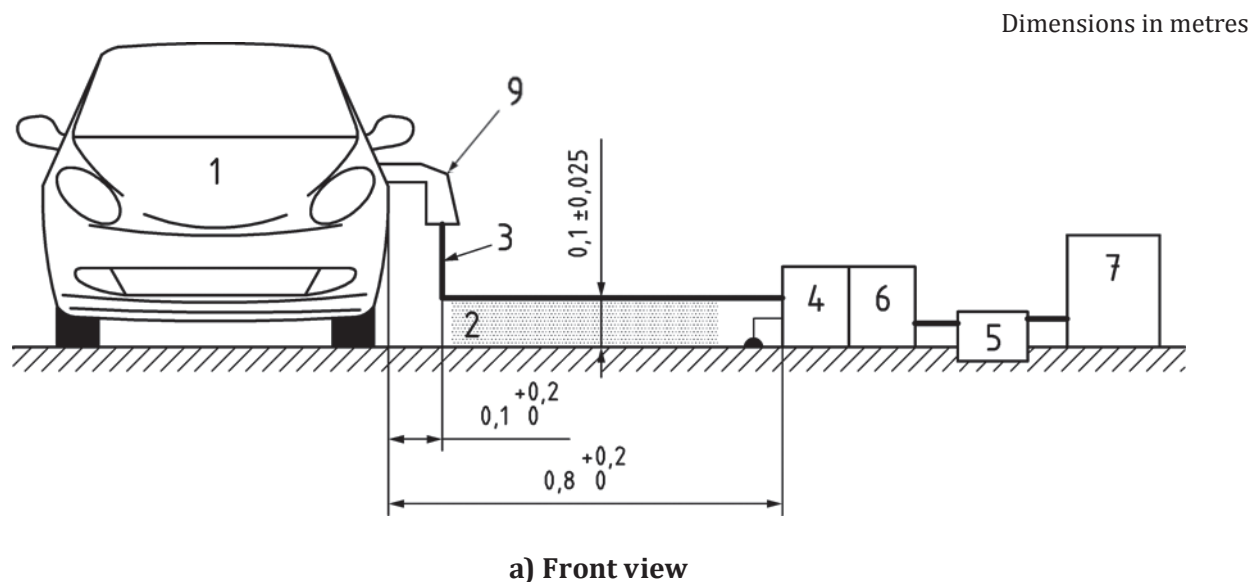

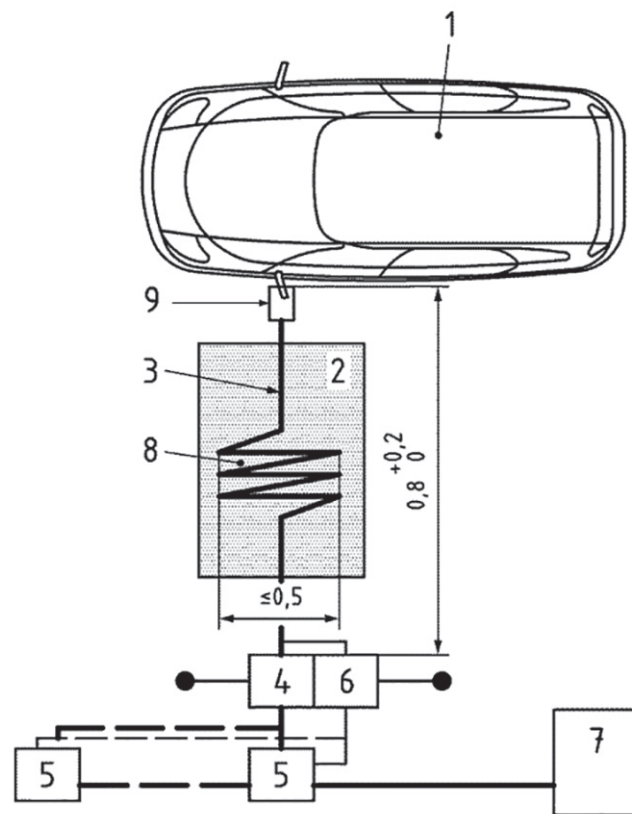

b) Top view

Key

- 1 vehicle under test
- 2 insulating support
- 3 charging / communication cable
- 4 a.c. artificial mains network(s) or d.c. HV artificial network(s) grounded
- 5 power mains socket
- 6 asymmetric artificial network(s) grounded (if used)
- 7 charging station
- 8 extraneous length Z-folded
- 9 charging cable plug

Figure 6 — Example of test setup for vehicle with plug located on vehicle side (a.c. or d.c. power charging with communication)

Dimensions in metres

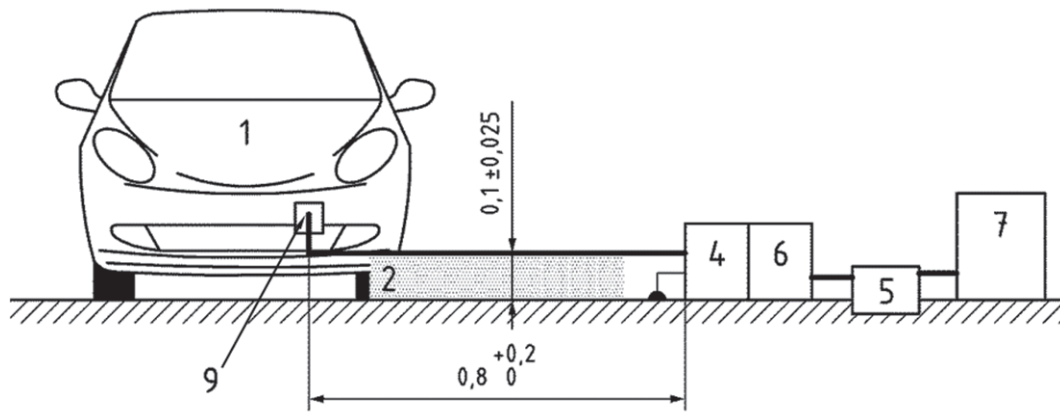

a) Front view

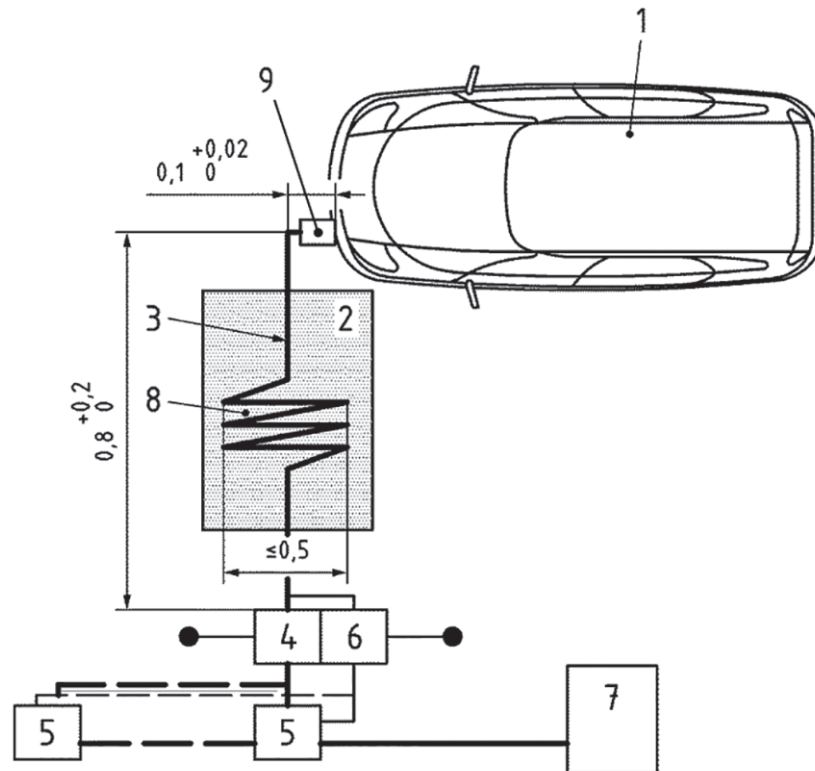

b) Top view

Key

- 1 vehicle under test
- 2 insulating support
- 3 charging / communication cable
- 4 a.c. artificial mains network(s) or d.c. HV artificial network(s) grounded
- 5 power mains socket
- 6 asymmetric artificial network(s) grounded (if used)
- 7 charging station
- 8 extraneous length Z-folded
- 9 charging cable plug

Figure 7 — Example of test setup for vehicle with plug located front / rear of vehicle (a.c. or d.c. power charging with communication)

7.3.3 Vehicle in charging mode through wireless power transmission (WPT)

The various configurations (with or without communication) are considered in this clause for a wireless power transmission system.

The WPT system mainly consists of:

- a primary device (coil external to vehicle);
- a secondary device (coil internal to vehicle);
- an off-board power unit.

7.3.3.1 Off-board power unit

The off-board power unit can be placed outside of the ALSE or anywhere on the ground plane of the ALSE.

Care shall be taken to avoid disturbances of the off-board power unit.

The harness between the off-board power unit and the vehicle shall be placed as close as possible of the ALSE ground plane with a length greater than or equal to 2 m.

7.3.3.2 Primary device

The primary device shall be aligned with the vehicle secondary device.

Example of test set-up is shown in [Figure 8](#).

Dimensions in metres

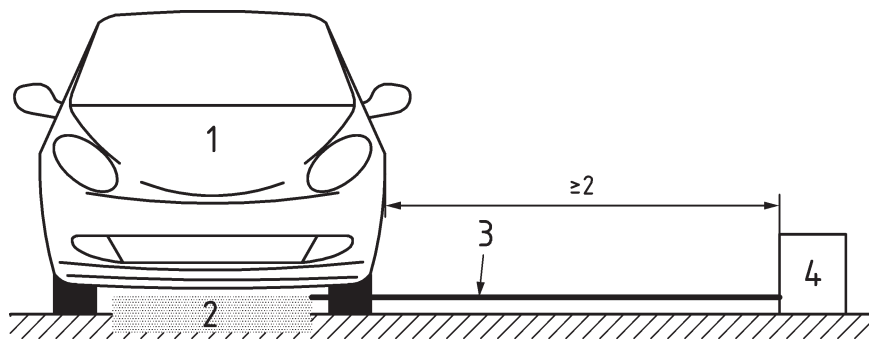

a) Front view

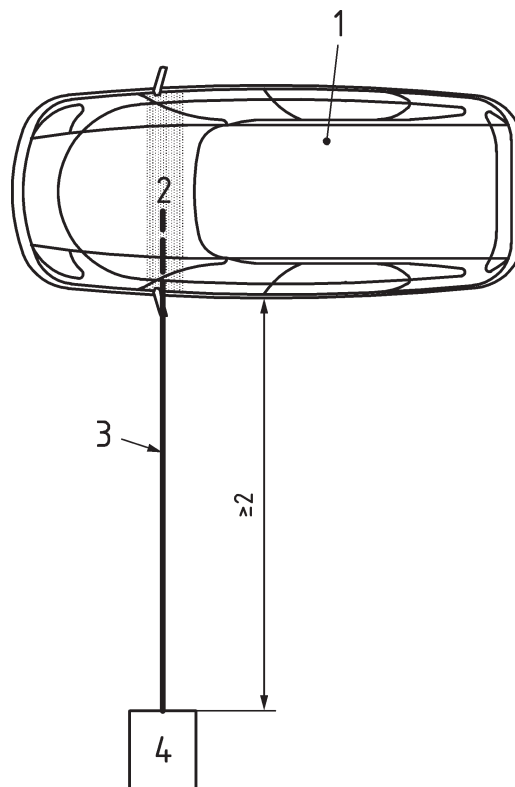

b) Top view

Key

- 1 vehicle under test
- 2 primary device
- 3 cable (between primary device and off-board power unit) placed directly on the ground plane
- 4 off-board power unit

Figure 8 — Example of test setup for vehicle in charging mode through wireless power transmission

8 Test procedure

The general arrangement of the disturbance source and vehicle represents a standardized test condition. Any deviations from the standard test configuration shall be agreed upon prior to testing and recorded in the test report.

The vehicle shall be made to operate under typical loading and operating conditions. These operating conditions shall be clearly defined in the test plan.

The orientation(s) of the vehicle for radiated immunity tests shall be defined in the test plan.

8.1 Test plan

Prior to performing the tests, a test plan shall be generated which shall include:

- test set-up;
- frequency range;
- reference point(s) (or line if four-probe method is used);
- vehicle mode of operation;
- vehicle acceptance criteria;
- definition of test severity levels;
- vehicle monitoring conditions;
- modulation;
- polarization;
- vehicle orientation;
- antenna location;
- test report content.

and any special instructions and changes from the standard test.

Every DUT shall be verified under the most significant situations, i.e. at least in stand-by mode and in a mode where all the actuators can be excited.

Additional vehicle positions, antenna locations or both could be needed to ensure complete illumination of the vehicle owing to the narrow beam widths of high-frequency antennas.

8.2 Test method

CAUTION — Hazardous voltages and fields can exist within the test area. Take care to ensure that the requirements for limiting the exposure of humans to RF energy are met.

The substitution method is based upon the use of forward power as the reference parameter used for field calibration and during test.

The test shall be performed with the substitution method.

This method is performed in two phases:

- field calibration (without the vehicle present);
- test of the vehicle.

The RF power required to achieve the required field strength is determined during the field calibration phase.

8.2.1 Field calibration

Calibration is performed without a vehicle in the test location.

The specific test level (field) shall be calibrated periodically by recording the forward power required to produce a specific field strength (measured with a field probe) for each test frequency.

This calibration shall be performed with an unmodulated sinusoidal wave.

The total field strength (regardless of direction) shall be calibrated for vertical and horizontal polarisations.

When requested, the values of forward and reverse power recorded in the calibration file and a precise description of the associated position of the field probe shall be included in the test report.

Place the field generating device at the intended location. Place a calibrated isotropic field probe at the reference point or, alternatively, four calibrated isotropic field probes on the vertical reference line (see [8.2.1.1](#) and [Figures 11](#) and [12](#)).

Normally, the vehicle reference point or line shall be used.

Above 200 MHz, the field uniformity at two points, one at 0,50 m on each side of the reference point (1 m height for vehicles with roof heights ≤ 3 m, 1,8 m height for vehicles with roof heights > 3 m) shall not be less than 50 % of the nominal field strength (relative to the reference point) for at least 80 % of the test frequency points. The field uniformity requirement shall be fulfilled separately for each polarization. For existing facilities where the field uniformity requirement cannot be met, this shall be stated in the test report. The user shall also ensure good reproducibility of the measurement.

Interpolation methods may be used between calibration levels to determine the specific forward power to be used for a test. From a practical viewpoint, the increment between calibration levels when the amplifier is operating in a linear range can be larger than when operating in a region where compression occurs.

8.2.1.1 Reference point and reference line

8.2.1.1.1 General requirements

For the frequency range from 0,01 MHz to 20 MHz or 30 MHz and 2 GHz to 18 GHz, a single field probe shall be used for calibration. A reference point is used with the single probe. The reference point is the point at which the field strength shall be established.

For the frequency range from 20 MHz or 30 MHz to 2 GHz, four field probe calibration method shall be used. The mean of the four probes readings is used as the calibration value. A vertical reference line is used with the four probe method. The reference line is a vertical line over which the field strength shall be established.

The 20 MHz or 30 MHz breakpoint is dependent on the design of the radiation source at the user's facility; typically the transformation from a TLS to an antenna.

8.2.1.1.2 Vehicle reference point and reference line

This is defined on the vehicle's centre line (plane of longitudinal symmetry), as follows.

- a) One probe position: at a height of $(1 \pm 0,05)$ m above the shielded enclosure floor for vehicles with a roof height ≤ 3 m, or $(1,8 \pm 0,05)$ m for vehicles with roof heights > 3 m. Other heights can be specified and measured.
- b) Four probe positions: at the following heights, as appropriate:
 - 0,5 m, 0,8 m, 1 m, and 1,2 m for vehicles with a roof height ≤ 3 m;
 - 1,2 m, 1,5 m, 1,8 m, and 2,1 m for vehicles with a roof height > 3 m.

Depending on vehicle geometry, the vehicle reference point is located $(0,2 \pm 0,2)$ m behind the front axle (see [Figure 8](#)), or $(1 \pm 0,2)$ m inside the vehicle, measured from the point of intersection of the vehicle windscreen and hood (see [Figures 9](#) and [10](#)), whichever results in a reference point closer to the antenna.

NOTE The alternative locations on the vehicle could necessitate the recording of a family of calibration data based on the reference point location relative to the chamber, i.e. the front axle dynamometer position moves with vehicle wheelbase adjustment.

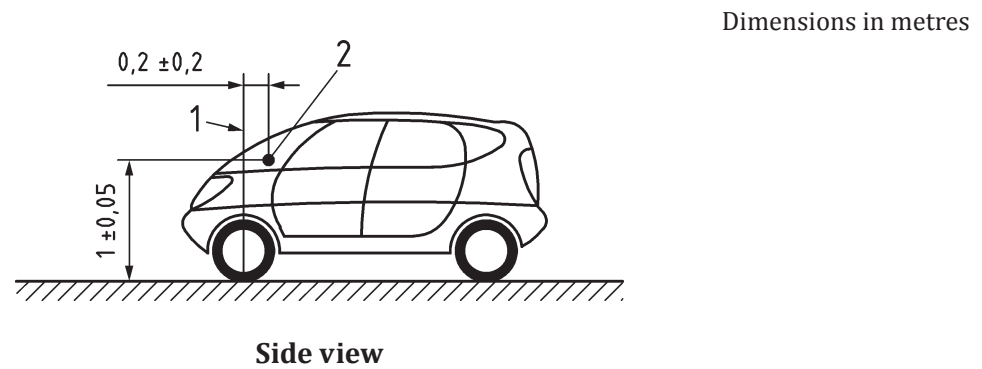

Key

- 1 front axle
- 2 vehicle reference point

Figure 9 — Example of vehicle reference point for passenger cars and light commercial vehicles

Dimensions in metres

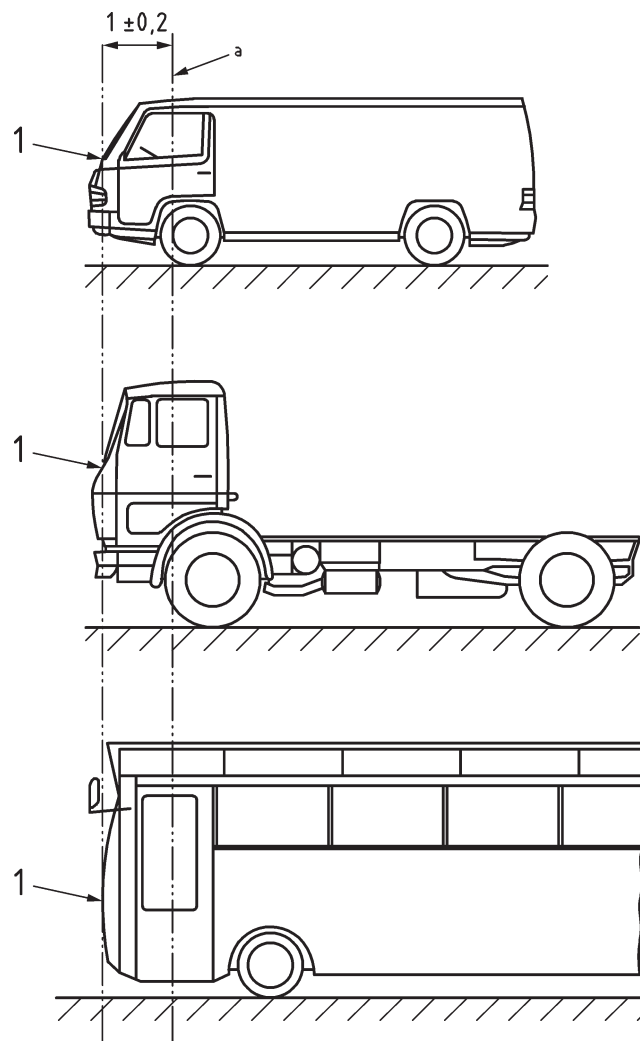

Side view

Key

- a Vehicle reference point lies in this line.
- 1 intersection of vehicle windscreen and bonnet

NOTE Not drawn to scale.

Figure 10 — Example of vehicle reference point for buses and commercial vehicles

8.2.1.1.3 Facility reference point and reference line

These are defined at the centre of the test region, as follows.

- a) One probe position: at a height of $(1 \pm 0,05)$ m above the shielded enclosure floor for vehicles with roof heights ≤ 3 m, or $(1,8 \pm 0,05)$ m for vehicles with roof heights > 3 m. Other heights can be specified and measured.
- b) Four probe positions: at the following heights, as appropriate:
 - 0,5 m, 0,8 m, 1 m, and 1,2 m for vehicles with a roof height ≤ 3 m;
 - 1,2 m, 1,5 m, 1,8 m, and 2,1 m for vehicles with a roof height > 3 m.

Examples of test set-up for single probe position calibration and four probe positions calibration are shown in [Figures 11](#) and [12](#).

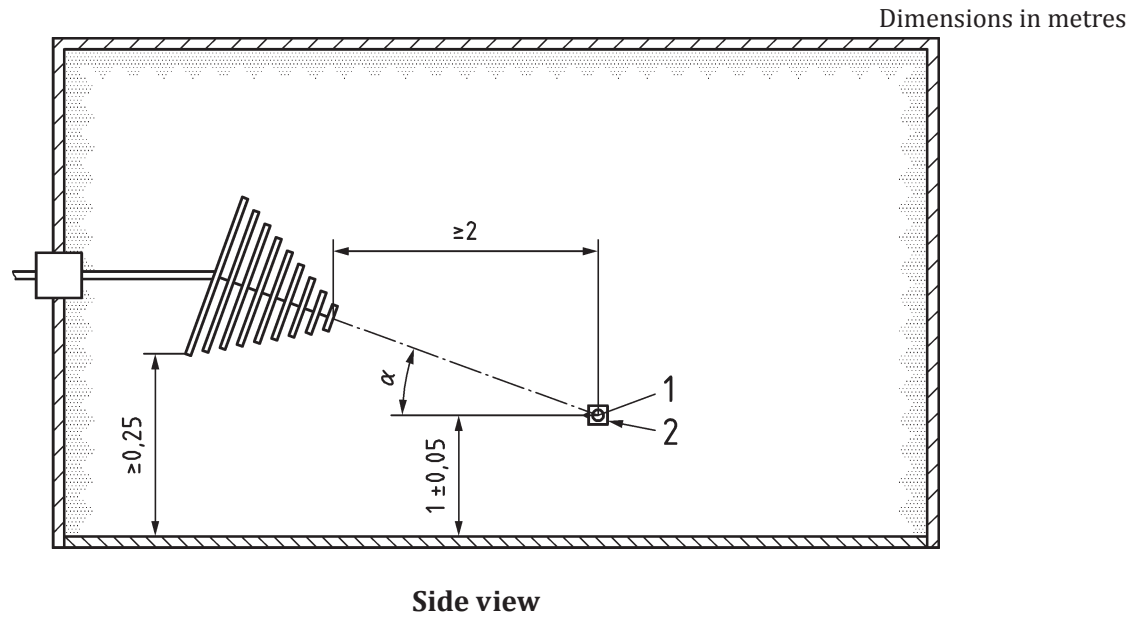

Key

- 1 reference point
- 2 field probe

Figure 11 — Example of a test set-up for single probe calibration (vehicle with roof height ≤ 3 m)

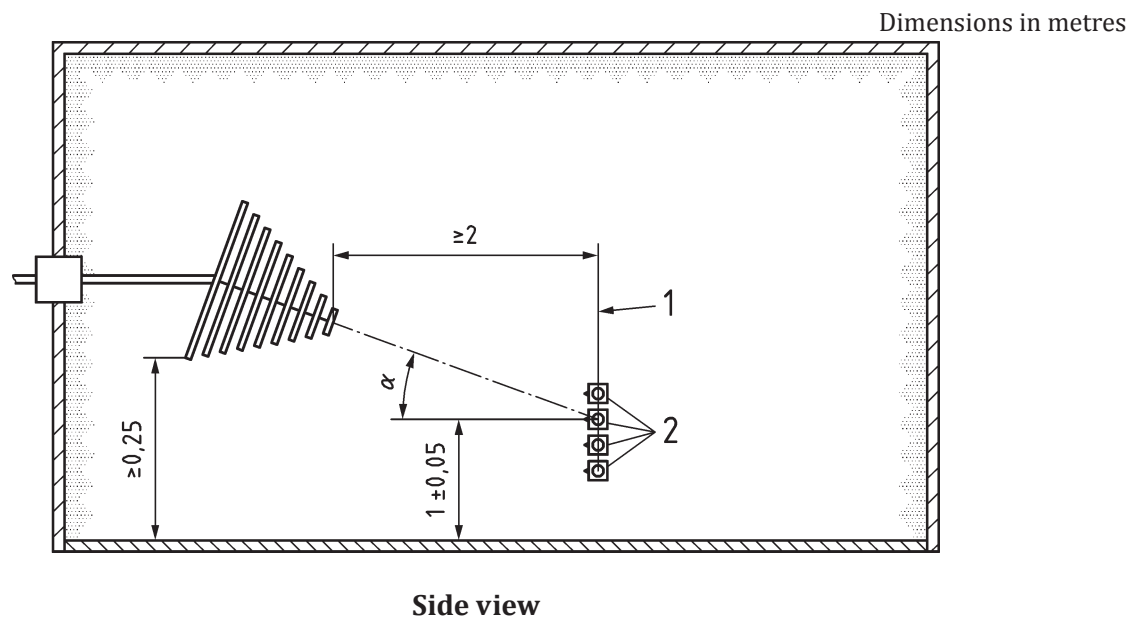

Key

- 1 reference line
- 2 4 field probe positions ($h = 0,5; 0,8; 1; 1,2$)

Figure 12 — Example of a test set-up up for four probe positions calibration (vehicle with roof height ≤ 3 m)

8.2.1.2 Vehicle test

The vehicle and associated equipment are installed in the test location as described in [Clause 7 \(Figures 3 to 7\)](#).

The position of the charging cable between the vehicle and the HV-AN/AMN, if any, shall remain unchanged regardless of the vehicle orientation and antenna location. The vehicle shall operate according to the test plan.

The test is conducted by subjecting the vehicle to the test signal based on the calibrated value as predetermined in the test plan.

NOTE A field probe can be placed in or outside the vehicle during the test.

Tests shall be conducted with both horizontally and vertically polarized fields over the test frequency range. Any exceptions to this practice shall be specified in the test plan.

With the field generating device in the specified polarization, scan the frequency range at the test level noting any anomalies.

Continue testing until all frequencies, modulations, polarizations, vehicle orientations and antenna locations specified in the test plan are completed.

8.3 Test report

As required by the test plan, a test report shall be submitted detailing information regarding the test equipment, test site, test set-up, systems tested, frequencies, power levels, system interactions and any other information relevant to the test.

Annex A (informative)

Function performance status classification

A.1 General

This annex gives examples of test severity levels which should be used in line with the principle of functional performance status classification (FPSC) described in ISO 11452-1.

A.2 Classification of test severity level

Examples of test severity levels for ALSE are given in [Table A.1](#).

Table A.1 — Example of test severity levels (ALSE)

Frequency band (MHz)	Test Level I (V/m)	Test Level II (V/m)	Test Level III (V/m)	Test Level IV (V/m)	Test Level V (V/m)
0,01 to 10	25	50	75	100	Specific values agreed between the users of this part of ISO 11451
10 to 30	25	50	75	100	
30 to 200	20	40	60	80	
200 to 1 000	20	40	60	80	
1 000 to 8 000	25	50	75	100	
8 000 to 18 000	25	50	75	100	

Frequency bands and test levels values given in this table are examples

A.3 Example of FPSC application using test severity levels

An example of severity levels is given in [Table A.2](#).

Table A.2 — Example of test severity levels (ALSE)

Test Severity Level	Function Category 1	Function Category 2	Function Category 3	Function Category 4
L4i	Level IV	-	-	-
L3i	Level III	Level IV	-	-
L2i	Level II	Level III	Level IV	-
L1i	Level I	Level II	Level III	Level IV

British Standards Institution (BSI)

BSI is the national body responsible for preparing British Standards and other standards-related publications, information and services.

BSI is incorporated by Royal Charter. British Standards and other standardization products are published by BSI Standards Limited.

About us

We bring together business, industry, government, consumers, innovators and others to shape their combined experience and expertise into standards-based solutions.

The knowledge embodied in our standards has been carefully assembled in a dependable format and refined through our open consultation process. Organizations of all sizes and across all sectors choose standards to help them achieve their goals.

Information on standards

We can provide you with the knowledge that your organization needs to succeed. Find out more about British Standards by visiting our website at bsigroup.com/standards or contacting our Customer Services team or Knowledge Centre.

Buying standards

You can buy and download PDF versions of BSI publications, including British and adopted European and international standards, through our website at bsigroup.com/shop, where hard copies can also be purchased.

If you need international and foreign standards from other Standards Development Organizations, hard copies can be ordered from our Customer Services team.

Subscriptions

Our range of subscription services are designed to make using standards easier for you. For further information on our subscription products go to bsigroup.com/subscriptions.

With **British Standards Online (BSOL)** you'll have instant access to over 55,000 British and adopted European and international standards from your desktop. It's available 24/7 and is refreshed daily so you'll always be up to date.

You can keep in touch with standards developments and receive substantial discounts on the purchase price of standards, both in single copy and subscription format, by becoming a **BSI Subscribing Member**.

PLUS is an updating service exclusive to BSI Subscribing Members. You will automatically receive the latest hard copy of your standards when they're revised or replaced.

To find out more about becoming a BSI Subscribing Member and the benefits of membership, please visit bsigroup.com/shop.

With a **Multi-User Network Licence (MUNL)** you are able to host standards publications on your intranet. Licences can cover as few or as many users as you wish. With updates supplied as soon as they're available, you can be sure your documentation is current. For further information, email bsmusales@bsigroup.com.

BSI Group Headquarters

389 Chiswick High Road London W4 4AL UK

Revisions

Our British Standards and other publications are updated by amendment or revision.

We continually improve the quality of our products and services to benefit your business. If you find an inaccuracy or ambiguity within a British Standard or other BSI publication please inform the Knowledge Centre.

Copyright

All the data, software and documentation set out in all British Standards and other BSI publications are the property of and copyrighted by BSI, or some person or entity that owns copyright in the information used (such as the international standardization bodies) and has formally licensed such information to BSI for commercial publication and use. Except as permitted under the Copyright, Designs and Patents Act 1988 no extract may be reproduced, stored in a retrieval system or transmitted in any form or by any means – electronic, photocopying, recording or otherwise – without prior written permission from BSI. Details and advice can be obtained from the Copyright & Licensing Department.

Useful Contacts:

Customer Services

Tel: +44 845 086 9001

Email (orders): orders@bsigroup.com

Email (enquiries): cservices@bsigroup.com

Subscriptions

Tel: +44 845 086 9001

Email: subscriptions@bsigroup.com

Knowledge Centre

Tel: +44 20 8996 7004

Email: knowledgecentre@bsigroup.com

Copyright & Licensing

Tel: +44 20 8996 7070

Email: copyright@bsigroup.com



...making excellence a habit.™