

Stationary source emissions — Determination of gas and particle-phase polycyclic aromatic hydrocarbons —

Part 1: Sampling

ICS 13.040.40

National foreword

This British Standard reproduces verbatim ISO 11338-1:2003 and implements it as the UK national standard.

The UK participation in its preparation was entrusted by Technical Committee EH/2, Air quality, to Subcommittee EH/2/1, Stationary source emissions, which has the responsibility to:

- aid enquirers to understand the text;
- present to the responsible international/European committee any enquiries on the interpretation, or proposals for change, and keep the UK interests informed;
- monitor related international and European developments and promulgate them in the UK.

A list of organizations represented on this subcommittee can be obtained on request to its secretary.

Cross-references

The British Standards which implement international publications referred to in this document may be found in the *BSI Catalogue* under the section entitled “International Standards Correspondence Index”, or by using the “Search” facility of the *BSI Electronic Catalogue* or of British Standards Online.

This publication does not purport to include all the necessary provisions of a contract. Users are responsible for its correct application.

Compliance with a British Standard does not of itself confer immunity from legal obligations.

Summary of pages

This document comprises a front cover, an inside front cover, the ISO title page, pages ii to v, a blank page, pages 1 to 25 and a back cover.

The BSI copyright date displayed in this document indicates when the document was last issued.

Amendments issued since publication

Amd. No.	Date	Comments

This British Standard was published under the authority of the Standards Policy and Strategy Committee on 25 June 2003

© BSI 25 June 2003

ISBN 0 580 42118 X

INTERNATIONAL
STANDARD

BS ISO 11338-1:2003

ISO
11338-1

First edition
2003-06-01

**Stationary source emissions —
Determination of gas and particle-phase
polycyclic aromatic hydrocarbons —**

Part 1:
Sampling

*Émissions de sources fixes — Détermination sous forme gazeuse et
particulaire des hydrocarbures aromatiques polycycliques —*

Partie 1: Échantillonnage



Reference number
ISO 11338-1:2003(E)

Contents

Page

Foreword	iv
Introduction	v
1 Scope	1
2 Normative references	1
3 Terms and definitions	2
4 Principles and minimum requirements for the three sampling methods	2
4.1 Principles	2
4.2 General minimum requirements for all sampling methods	2
4.3 General preparation and sampling	3
5 Method A — Dilution method	4
5.1 Principle	4
5.2 Minimum requirements	4
5.3 Preparation and sampling	5
6 Method B — (Heated) filter/condenser/adsorber method	7
6.1 Principle	7
6.2 Minimum requirements	7
6.3 Preparation and sampling	7
7 Method C — Cooled probed/adsorber method	9
7.1 Principle	9
7.2 Minimum requirements	9
7.3 Preparation and sampling	10
Annex A (informative) Applicability of the sampling methods	12
Annex B (informative) Schematic presentations, dimensions and materials of some tested sampling devices	14
Bibliography	25

Foreword

ISO (the International Organization for Standardization) is a worldwide federation of national standards bodies (ISO member bodies). The work of preparing International Standards is normally carried out through ISO technical committees. Each member body interested in a subject for which a technical committee has been established has the right to be represented on that committee. International organizations, governmental and non-governmental, in liaison with ISO, also take part in the work. ISO collaborates closely with the International Electrotechnical Commission (IEC) on all matters of electrotechnical standardization.

International Standards are drafted in accordance with the rules given in the ISO/IEC Directives, Part 2.

The main task of technical committees is to prepare International Standards. Draft International Standards adopted by the technical committees are circulated to the member bodies for voting. Publication as an International Standard requires approval by at least 75 % of the member bodies casting a vote.

Attention is drawn to the possibility that some of the elements of this document may be the subject of patent rights. ISO shall not be held responsible for identifying any or all such patent rights.

ISO 11338-1 was prepared by Technical Committee ISO/TC 146, *Air quality*, Subcommittee SC 1, *Stationary source emissions*.

ISO 11338 consists of the following parts, under the general title *Stationary source emissions — Determination of gas and particle-phase polycyclic aromatic hydrocarbons*:

- *Part 1: Sampling*
- *Part 2: Sample preparation, clean-up and determination*

Introduction

Polycyclic aromatic hydrocarbons (PAHs) are a group of aromatic hydrocarbons, some members of which are probable and others possible human carcinogens. Human exposure to PAHs can occur via food, soil, water, air and skin contact with materials containing PAHs. While PAH are formed in natural processes (e.g. forest fires), man-made atmospheric emissions of these compounds originate from the combustion of coal, gas, wood and oil, from a range of industrial processes such as coke production, aluminium smelting and from vehicles.

The quantification of atmospheric releases of PAH from stationary sources is an important part of the environmental impact assessment of certain industrial processes.

Stationary source emissions — Determination of gas and particle-phase polycyclic aromatic hydrocarbons —

Part 1: Sampling

1 Scope

This part of ISO 11338 describes methods for the determination of the mass concentration of polycyclic aromatic hydrocarbons (PAHs) in flue gas emissions from stationary sources such as aluminium smelters, coke works, waste incinerators, power stations, and industrial and domestic combustion appliances.

This part of ISO 11338 describes three sampling methods, which are here regarded as of equivalent value, and specifies the minimum requirements for effective PAH sampling. The three sampling methods are the dilution method (A), the heated filter/condenser/adsorber method (B) and the cooled probe/adsorber method (C). All three methods are based on representative isokinetic sampling, as the PAHs are commonly associated with particles in flue gas.

Information is provided to assist in the choice of the appropriate sampling method for the measurement application under consideration.

This part of ISO 11338 is not applicable to the sampling of fugitive releases of PAHs.

NOTE Methods for sample preparation, clean-up and analysis are described in ISO 11338-2 and are intended to be combined with one of the sampling methods described in this part of ISO 11338 to complete the whole measurement procedure.

2 Normative references

The following referenced documents are indispensable for the application of this document. For dated references, only the edition cited applies. For undated references, the latest edition of the referenced document (including any amendments) applies.

ISO 4225:1994, *Air quality — General aspects — Vocabulary*

ISO 9096:1992, *Stationary source emissions — Determination of concentration and mass flow rate of particulate material in gas-carrying ducts — Manual gravimetric method*

ISO 12141, *Stationary source emissions — Determination of mass concentration of particulate matter (dust) at low concentrations — Manual gravimetric method*

3 Terms and definitions

For the purposes of this document, the terms and definitions given in ISO 4225 and the following apply.

3.1

chimney

stack or final exit duct on a stationary process used for the dispersion of residual process gases

3.2

mass concentration

concentration of a substance in an emitted flue gas, expressed in units of mass per cubic metre

3.3

polycyclic aromatic hydrocarbon

PAH

compound that contains two or more fused aromatic rings made up only of carbon and hydrogen atoms

3.4

stationary source emissions

gases emitted by a stationary plant or process and transported to a chimney for dispersion into the atmosphere

4 Principles and minimum requirements for the three sampling methods

4.1 Principles

Devices for the three sampling methods, illustrated in Figure B.1 (Method A), Figures B.2 and B.3 (Method B) and Figure B.7 (Method C), can be applied for the sampling of PAH from stationary sources. They are regarded as likely to produce equivalent results, however no comparative trials have been published to establish this.

In general, as PAHs are present in both the vapour phase and on particles, the PAHs are collected in several parts of the sampling train: the particle filter, condensate flask and solid or liquid adsorber. The choice of the sampling method depends on the measurement application (see Table A.1 and Table A.2).

The three sampling methods A, B and C are discussed in detail in Clauses 5, 6 and 7, respectively.

Annex A provides further information on the applicability of the sampling methods.

After extraction and clean-up, the PAH are quantified either by High Performance Liquid Chromatography (HPLC) using a fluorescence detector, diode array or UV detector, or by GC-FID/MS (low or high resolution MS). Applicable methods for preparation, clean-up and determination are described in ISO 11338-2.

4.2 General minimum requirements for all sampling methods

The following steps shall be carried out irrespective of the sampling method chosen.

- a) Carry out isokinetic sampling at representative points in the duct cross-section, in accordance with ISO 9096.
- b) Before sampling, rinse the inside of the sampling device with acetone, dichloromethane or methanol and then with toluene. Alternatively, immerse the parts in methanol and subject them to ultrasonic vibration for 2 h, and subsequently dry at 150 °C. Store these washings and analyse only if the results indicate that the sampler could have been contaminated before sampling, for example if the results unexpectedly exceed the relevant emission limit.
- c) Carry out a leak check before every sampling procedure.

If the joints in the equipment are of ground glass, any slight leak can be dealt with by wetting the joints with a small amount of clean water. Greases should never be used for this purpose.

- d) The minimum velocity in the sorbent bed shall be:
 - for XAD-2 (thickness 50 mm, volume 35 cm³): less than 34 cm/s;
 - for PU foam (thickness 50 mm, volume 98 cm³): less than 30 cm/s.
- e) Check each batch of filters, solvents and reagents for preparation for background PAH levels.
- f) The glass parts of the sampling devices shall be protected from light during and after sampling, cooled after sampling and cleaned after the extraction procedure.
- g) Clean the probe thoroughly after each sample is taken. Add the probe rinse to the rinse from the rest of the sample.
- h) If the probe is contaminated with particles which cannot be easily removed, wipe away the particles with a quartz wool swab steeped in acetone. Extract this quartz wool swab together with the filter.
- i) If the sampling device is cleaned at the measurement site for reuse there, the probe, the nozzle, the filter casings and all other parts of the sampling apparatus which have been in contact with the sample gas and so could still be contaminated shall, after cleaning to remove the sample, be rinsed with acetone, dichloromethane or methanol and followed by a toluene rinse. As before, this sample shall be preserved in case of concern about cross-contamination between samples.
- j) Extract samples within 1 week and preferably within 24 h. Store the samples in the dark at – 7 °C.

4.3 General preparation and sampling

The following steps shall be carried out irrespective of the sampling method chosen.

- a) Choose the sampling location with regard to the safety of the personnel, the suitability of the measurement cross-section (in accordance with ISO 9096), accessibility and availability of electrical power.
- b) Before the sampling starts, determine the flue gas density, pressure, temperature and if possible the gas composition. In addition, to ensure isokinetic conditions, determine the velocity and temperature profile across the cross-section of the flue gas channel. Choose the correct size of the sampling probe nozzle calculated from the flue gas velocity and the approximate maximum flowrate achievable through the sampler to ensure that the sampler will be capable of isokinetic sampling at all the measurement points in the duct cross-section.
- c) The parts of the sampler which come into contact with the sample and which have been carefully cleaned in the laboratory shall be
 - transported in clean boxes, all the components having been sealed carefully;
 - assembled *in situ*, carefully avoiding contact with the operator's fingers on the parts of the sampling equipment which will later be in contact with the sample.
- d) After sampling, store all materials containing sampled PAH under cooled conditions and protected from light.

The following data shall be recorded during sampling:

- sample volume (standard conditions);

- sample temperature (in the gas meter);
- mean flue gas velocity;
- diameter of the stack;
- moisture content of the flue gas;
- mean oxygen content of the flue gas during the sampling period;
- static pressure and temperature in the stack;
- sampling flowrate.

To provide an estimate of the contamination present in the sampler and sampling matrices before sampling and as a result of sampler assembly and transport, an additional sampling unit may be taken to the sampling location, rinsed and analysed. Unfortunately contamination incidents are random in their occurrence, and so this will only provide an estimate of the blank values. As a result, subtraction should not take place. However, results in which the contribution of this blank is substantial should be treated with caution.

NOTE In order to obtain information on the performance of the sampler, internal standards can be added to the sampling equipment (e.g. on the filters or the adsorbent) and their recovery measured. However, the internal standards are bound to the filter in a manner different to that by which the native PAHs are bound to the fly ash, so there may be differences in behaviour during sampling and extraction.

5 Method A — Dilution method

5.1 Principle

A proportion of the flue gas is collected isokinetically via a sampling probe heated to the temperature of the flue gas. The flue gas is cooled very rapidly to temperatures below 40 °C in a mixing chamber using dried, filtered and, if appropriate, cooled air. This dilution prevents condensation of water present in the gas sample. In addition, dilution seeks to minimize the reactions of the separated PAH with other flue gas components, e.g. NO, NO₂, SO₂, SO₃ and HCl. The sampling conditions are similar to the natural dilution and cooling processes of flue gases emitted into the atmosphere.

The diluted flue gas is then passed through a silicone-bonded glass fibre filter impregnated with paraffin oil. This retains PAH components with 4 to 7 rings. If sampling for more volatile PAHs (2- or 3-ring compounds) is required, a solid adsorbent¹⁾ can be incorporated downstream of the filter in the sampling train.

The sample gas flowrate through the sampling probe should be in the range of 2 m³/h to 8 m³/h. Normally within 1,5 h of sampling, sufficient PAH for analysis has been collected, usually in about 8 m³ to 10 m³. After sampling, the filter and, if used, the solid adsorbent are extracted and analysed.

A schematic representation of a tested sampling device is given in Figure B.1.

5.2 Minimum requirements

The following procedures shall be followed.

- a) Keep the filter at < 40 °C. Avoid condensation on the filter.

1) Porapak PS is an example of a suitable product available commercially. This information is given for the convenience of users of this part of ISO 11338 and does not constitute an endorsement by ISO of this product.

- b) Include a solid-adsorber stage downstream of the filter if volatile PAH are to be reported.
- c) Change the filter and solid-adsorber unit for cleaning the dilution air after a gas volume of 100 m³ has been sampled.

5.3 Preparation and sampling

5.3.1 Sampling train and its operation

The unit for sampling a given quantity of partial flue gas consists of a nozzle, an elbow joint, and the probe. The nozzle used shall have an effective diameter of between 6 mm and 30 mm. Choose the correct nozzle size, in accordance with ISO 12141 or ISO 9096, to ensure isokinetic sampling is possible. Heat the probe to the same temperature as the flue gas; this prevents any changes in the PAH due to temperature increases as well as any change in the state of aggregation of the sample gas components. Measure the sampled gas temperature at the exit from the probe and control the temperature of the probe by use of a thermostat. Sampling probes with a diameter of 8 mm to 10 mm are used; the diameter of the probe is dependent on the dimensions of the flue gas channel. The heat output of the probe is 250 W/m to 500 W/m, depending on the tube length and extent of insulation.

In the mixing chamber the flue gas is mixed turbulently with dry ambient air. This dilution air enters at right angles to the direction of flow of the sampled flue gas, and is first deflected by the walls of the chamber and then mixes with the flue gas, which has passed through an insulated tube (8 mm to 10 mm long) which projects into the chamber. The gas-mixing zone is 150 mm long and has a diameter of 50 mm.

The sample filter is located at the exit of the mixing chamber, and the dilution-air filter is located at the entry to the mixing chamber. The filters are mounted in two-part filter casings, sealed with O-rings and then fixed with snap closures to the mixing channel. Solid adsorbers may be linked downstream of both filters if the measurement of 2- or 3-ring PAHs is required. The filter casings contain sensors for measuring the temperature of the diluted sampling gas stream and the dilution air.

The sampling filter casing is connected with a flexible hose to a unit which measures the total flowrate of the sampled flue gas and the dilution air. The flow of dilution air is measured before the dilution air filter casing by a similar unit. The measurement of the flowrates is carried out by measuring the pressure drop across orifice plates and the absolute pressure and by Pt-100 temperature sensors. Other calibrated suitable flowrate-measuring devices may be used. The dimensions of the orifice plates are such that the ratio of the orifice diameter (d) to the plate diameter (D) is $(d/D)^2 = 0,56$. The calibration constants for the orifice plates are determined at suitable intervals at the laboratory and then checked by operating the two nozzles from a sampler in series.

The regulation of the sample flowrate to ensure isokinetic sampling can be fully automatic via a microprocessor-controlled evaluation and control unit; but manual operation is also possible as long as the flow is adjusted at least every 10 min. The automatic control system ensures that the sample gas flowrate is maintained at isokinetic conditions and the filter temperature does not exceed 40 °C. The initial values are set before sampling, based on temperature, pressure and gas velocity in the flue gas duct and in both flow measurement units, as well as the composition of the flue gas. The theoretical value for sample gas flowrate is then calculated using the measured temperature, pressure and gas velocity in the flue gas duct and in both flow measurement units at intervals of 1 s and, if appropriate, the sample and dilution air flowrates are then altered automatically.

Measuring devices for pressure, temperature, flue gas velocity and flue gas composition, especially moisture, are required.

A vacuum pump, a blower²⁾ or a compressed-air-driven ejector can be used for the suction.

2) A Roots blower is an example of a suitable product available commercially. This information is given for the convenience of users of this part of ISO 11338 and does not constitute an endorsement by ISO of this product.

The dilution air is passed through a drying tower to reduce atmospheric moisture and cooled, if appropriate, using a heat exchanger.

5.3.2 Preparation

Before sampling, an internal standard can be dissolved in methanol or acetone and uniformly distributed over the filter surface and/or the solid adsorber. The filter shall not be used for sampling until at least 2 h after the internal standard has been applied. The filter with the internal standard may be stored for several days if protected from light at -7°C .

Check the sampling system for leaks before the sampling probe is inserted into the flue gas duct. To check the system for the absence of leaks, close with stoppers both the nozzle of the sampling probe and the fitting by which air enters the drying tower. Turn on the suction aggregate to produce the lowest absolute pressure within the sampler that will be used during sampling. Then close the shutoff valve. The measured leak volume shall be less than 5 % of the sampling flow. If the leak is larger than this, steps shall be taken to identify and eliminate the leak (which most often arises from a defective O-ring or from a loose screw connection).

Before sampling starts, check the experimental parameters and constants stored in the evaluation and control unit, if one is used and, if necessary, alter to parameters valid for the next sampling process.

Then fit the probe in the flue gas channel, with the shutoff valve closed to prevent backward flow through the sampler. Preheat the suction tube to the temperature of the flue gas, normally after the leak check has been performed.

Replace the filter and the solid adsorber unit used to clean the dilution air after a volume of 100 m^3 has passed through them.

5.3.3 Sampling

Once the sampler nozzle has been placed at the correct initial sampling position within the duct, sampling can start. Regulate the dilution sampler either by an automatic evaluation and control unit or by manual control. At the start of the sampling process, set the dilution air to a maximum, open the shutoff valve and adjust the valves controlling the dilution air and sampled flue gas very rapidly until the correct flue gas flowrate for isokinetic sampling is established. Regulate the dilution air flowrate by the valve to give a temperature of 40°C at the sampling filter (see manufacturers' operation manual).

During the sampling procedure using an automatic control unit, the display screen shall show the temperature at the sampling filter, the sample volume already aspirated, the aspirated partial gas stream and the temperature, pressure, differential pressure, the flue gas streams and the cooling air as well as the total gas stream (flue gas - cooling air) at differential intervals of 1 s. Similar parameters shall be recorded at intervals of 10 min or less if manual control is carried out.

Sampling may be interrupted at any time and then continued with unchanged settings, e.g. for system measurements, to incorporate the sampling probe in another measurement axis. Closing the shutoff valve and shutting off the pump will terminate sampling. Depending on the automatic control unit used, the data obtained can be printed out, stored or displayed.

The sampler is then disassembled and the sample filter and solid adsorber are removed and stored. The sampling filter is protected from UV radiation, sealed in an air tight enclosure such as a polyethylene bag and stored under cool conditions (-7°C) in the dark until required for extraction. The adsorbent is left in the adsorbent cartridge which is closed off with glass stoppers and protected from light. The parts of the sampling equipment train before the adsorbent cartridge which came into contact with flue gas shall be checked at the conclusion of the measurements for deposits and cleaned, if necessary. Any residues shall be added to the material to be analysed, to be extracted in conjunction with the filters.

After sampling, analyse the following parts:

— filter;

- solid adsorber;
- rinsing solutions.

NOTE The dilution air filter and adsorbent can be analysed as a blank, to obtain information on any possible contamination from the ambient air during sampling

6 Method B — (Heated) filter/condenser/adsorber method

6.1 Principle

Flue gas is drawn from the duct isokinetically through a nozzle and a heated sampling probe to a particle filter in a heated enclosure. Keep the filter above the dewpoint of the flue gas but at a temperature no higher than the duct temperature. If there is a high particle content in the sample gas, a cyclone or quartz wool cartridge can be used upstream of the filter to prevent the filter being overloaded. A properly sealed quartz, glass or titanium-lined suction probe shall be used. Pass either all, a known fraction, or a known amount of the flow, through a condenser which is attached downstream of the filter to cool the sample gas to below 20 °C. Capture gaseous PAH by condensation in impingers and/or adsorption on solid adsorbents downstream from the condenser. As the flue gas cools in the condenser, moisture is collected. Sampler designs have been used in which either the condensate is collected in a flask before the flue gas passes through the adsorber, or the condensate and the gas pass through the adsorber and then to the condensate flask. No comparisons between the two approaches are known at the time of writing.

The sample volume flowrate can be from 1 m³/h to 6 m³/h, depending on the design of the sampling train.

After sampling, rinse the sampling device and the adsorber or impinger solutions, depending on which is used, and extract and analyse the filter and acetone/toluene washings.

A schematic representation of a tested sampling device is given in Figures B.2 and B.3.

6.2 Minimum requirements

The following procedures shall be observed.

- a) Place the filter in the duct or outside the stack in a heated filter holder.
- b) Maintain the filter, if it is within the duct, at a temperature equal to that of the flue gas.
- c) Heat the filters used outside of the stack to a temperature above the flue gas dewpoint.
- d) The sample gas temperature after passing through the condenser shall be less than 20 °C.
- e) Impinger fluids or solid adsorbents can be used to capture gaseous PAH. The collection efficiency of the adsorber or impingers shall be validated for the PAH compounds of interest.

6.3 Preparation and sampling

6.3.1 Sampling train and its operation

The sampling can be carried out with or without division of the sample gas flow. Flow division (splitting) is used when the flow collected isokinetically is too high to have good adsorption efficiency when passing through the available adsorption unit. The common sample apparatus consists of a particle filter unit, a condenser, an adsorption unit and a flow control device with a gas meter, a pump and a flow regulator.

The probe and sampling nozzle shall be made of titanium, stainless steel, glass or quartz. Polytetrafluoroethylene (PTFE) or fluoroelastomer³⁾ can be used to seal joints and as a coating on the filter support. If flow division is needed, place a flow divider behind the particle filter. Place a device for measuring and regulating the flow in the main stream in order to achieve isokinetic conditions. Treat the side stream as described for the device without flow division. Clean the sampling probe after sampling by washing with toluene or hexane. It is recommended that a glass or quartz tube be inserted into the suction tube as a liner. This can be removed after sampling, and later cut into pieces for extraction in the laboratory. Connect the filter to the sampling probe either outside or inside the duct. If the filter is outside it must be heated. With flue gas temperatures of more than around 120 °C, an air- or water-cooled suction tube may be used. If the sampled flue gas contains a high concentration of particles (e.g. >100 mg/m³) a quartz wool pre-filter or a cyclone can be used before the final absolute filter, which is normally flat and hence can block at high particle loadings and cause large pressure drops.

Cool the sample gas downstream with a condenser and maintain its temperature below 20 °C. Operate the cooler fluid with the temperature between 0 °C and 20 °C but as low as possible. Examples of filter housings, condensers and adsorber systems are given in Annex B.

The gaseous PAH are trapped in the subsequent adsorption stage (a solid adsorber cartridge filled with e.g. adsorbent⁴⁾ and/or polyurethane plug).

Connect the exhaust of the adsorption stage to impingers which trap condensed liquid. Then draw sample gas through the volume measurement and regulation unit and the pump by tubing. The condensate trap may be placed either before or behind the solid adsorber cartridge.

During sampling, measure the temperature of the sample gas at the beginning and at the end of the condensate flask.

6.3.2 Preparation

Connect the sampling apparatus, using spherical ground-glass joints and fork clamps. Perform a leak test before sampling.

Carry out a leak check in one two ways:

- a) evacuate the sampling train with plugged nozzle, adjust the volume flow valve to the minimum vacuum used during sampling, and then measure the volume flowrate, which shall be less than 5 % of the normal flowrate;
- b) evacuate the sampling train with plugged nozzle to about 500 hPa and, using the observed rate of increase in pressure within the system together with knowledge of the system volume, estimate the leak rate, which shall be less than 5 % of the normal sample flowrate.

Before sampling, either the filter or adsorber unit can be spiked with different internal standards. The filter shall be left to stand after spiking for at least 2 h before sampling is carried out. The compartments charged with internal standards may be stored for several days in the dark at – 7 °C. If during sampling a change of the filter becomes necessary, for example because of high dust load, the new filter shall be spiked with the same internal standards. This shall be taken into account during subsequent calculations of standard recovery and concentrations.

3) Viton® is an example of a suitable product available commercially. This information is given for the convenience of users of this part of ISO 11338 and does not constitute an endorsement by ISO of this product.

4) XAD-2 resin and Porapak PS are examples of suitable products available commercially. This information is given for the convenience of users of this part of ISO 11338 and does not constitute an endorsement by ISO of these products.

6.3.3 Sampling

During sampling, position the probe at the chosen measurement point in the cross-section of the duct. Then switch on the pump, and regulate the flowrate of sample gas to guarantee isokinetic sampling. Regulate the temperature of the condenser cooling fluid so that the temperature does not fall below 0 °C, in order to avoid ice formation inside the condenser.

The size of the condensate collection flask shall be chosen taking into account the moisture content of the flue gas and the quantity of flue gas to be sampled.

At the end of sampling, close the valve to stop backward flow of air through the sampler, switch off the pump and remove the sampling train from the duct. Then carry out the following procedures.

- Rinse the probe carefully with acetone, hexane and then toluene. Remove particles adhering to the inside of the probe with a pre-cleaned glass or quartz wool swab. Store the collected material in the dark in a cool place (−7 °C).
- Store the filter in a closed glass container protected from light in a cool place (−7 °C).
- Close off the condenser and adsorber with ungreased glass stoppers. Store the sample in the dark in a cool place (−7 °C).
- If impingers are used, pour the contents into brown bottles. Rinse the impingers with acetone, hexane and toluene. Add the rinsing solution to the impinger fluid and store it protected from light in a cool place (−7 °C).

7 Method C — Cooled probed/adsorber method

7.1 Principle

The flue gas is drawn isokinetically through a nozzle into a water-cooled probe. The materials of the probe are not important as long as they resist the flue gas conditions and the temperature differentials across the probe. Stainless steel has been successfully used. The probe is lined with a glass, quartz or titanium insert through which the flue gas passes. The insert is fixed within the probe and cooled by a supply of water passing around its outside. The liners can be cut into pieces after sampling and be extracted in the laboratory.

The sample gas is cooled within the probe to below 40 °C. The flue gas and condensate pass out of the probe into a condensate flask in which the condensate is caught. Downstream, solid adsorbers are used in order to collect the gaseous PAH. Before the last solid adsorber, a filter (0,3 µm pore size) is used to capture particles.

Instead of the cooled probe and the condensate flask, a special condensate flask with an integral impinger tube cooled by an ice bath can be used.

The flue gas volume flowrate may vary from 0,5 m³/h to 2 m³/h depending on the design of the sampling train.

A schematic representation of a tested sampling device is given in Figure B.7.

7.2 Minimum requirements

The gas temperature downstream of the cooled probe shall be < 40 °C.

7.3 Preparation and sampling

7.3.1 Sampling train and its operation

The design of the sampling train shall be suitable for the measurement being carried out and shall enable collection of sufficient sample to meet the study objectives. The flue gas is sucked isokinetically through a nozzle into the water-cooled probe liner. The use of a probe made of PTFE is possible at temperatures of less than 180 °C. The probe liner is coaxially fixed into a double-jacketed probe. The cold water flows up the inner of two concentric pipes countercurrent to the flue gases and then out at the end of the probe into the outer jacket and back to the other end. Care shall be taken at very high flue-gas temperatures that the water flowrate is sufficient to prevent the water being turned to steam.

After the suction tube, a condensate flask captures the flue gas condensate. The adsorption stage downstream can consist of impingers containing diethylene glycol or ethoxyethanol and a solid adsorber consisting of adsorbent and/or polyurethane foam plug. Normally a two-stage adsorber is used, a filter being held between the two stages to capture any particles that have passed through the condensate flask.

After the last adsorption stage, connect a drying tower, a gas meter and a flue-gas flowrate control unit.

All connections from the outlet of the sampling probe to the inlet of the adsorption stage shall be made of glass. Because of the danger of glass damage, spherical joints are recommended. Screw-thread tubes with plastic caps and PTFE-sealed threads can also be used. Connections via hoses are not permitted, however an air-cooled suction tube connected to a efficient condenser and an impinger inserted into a condensate bottle in an ice bath may be used.

NOTE By using several glass tubes equipped with spherical joints, the condensate flask and solid adsorber can be connected with the probe in such a way that movement of the nozzle at the end of the probe to the points required by ISO 9096 within the cross-sectional area of the stack are possible. The assembled apparatus is fixed in a support and in this way, it can be transported to the measurement location.

7.3.2 Preparation

Before sampling, rinse the sampling device with acetone or methanol and then with toluene.

Other cleaning procedures may be used if they have been demonstrated to produce reliably blank levels which are not significant in terms of the measurements to be reported.

Connect the probe, the elbow joint and the suction tube.

Connect the drying tower and the volume flow measurement and regulation unit with the solid adsorber/filter.

Insert the condensate bottle.

Carry out a leak check in one of two ways:

- a) evacuate the sampling train with plugged nozzle, adjust the volume flow valve to the minimum vacuum used during sampling, and then measure the volume flowrate, which shall be less than 5 % of the normal flowrate;
- b) evacuate the sampling train with plugged nozzle to about 500 hPa and, using the observed rate of increase in pressure within the system together with knowledge of the system volume, estimate the leak rate, which shall be less than 5 % of the normal sample flowrate.

If an internal standard is used, it shall be spiked into the condensate flask or the condenser unit.

Prior to sampling, prepare the ice bath.

7.3.3 Sampling

First, turn on the cooling-water feed for the probe. Then move the probe into the correct initial position within the duct. Switch on the pump while keeping the valve between pump and gas meter closed. The sampling apparatus is now ready for sampling.

Maintain the sample gas temperature below 40 °C after passing the cooled probe. Cool the condensate flask and other liquid impingers in an ice bath.

If the condensate bottle has to be changed during sampling, the new one shall be spiked with the internal standard, if applicable. This shall be taken into account in calculation of standard recoveries and concentrations.

At the end of sampling:

- a) switch off the pump;
- b) drain the cooling fluid from the suction tube. The probe may be rinsed while still connected or later;
- c) disconnect the sampling device;
- d) rinse the probe thoroughly several times. [If an insert in the suction tube is used, it can be cut into pieces and placed in a closed glass bottle and stored in the dark in a cool place (-7 °C)];
- e) pour the condensate fluids and the solvent used for rinsing into brown glass bottles, seal and store in the dark in a cool place (-7 °C).

After sampling, the following parts shall be included in the extraction and analysis:

- combined condensate and rinsing solutions;
- solid adsorber (if used);
- filter;
- glass liner (if applicable);
- back-up adsorbent (if applicable).

Annex A (informative)

Applicability of the sampling methods

Tables A.1 and A.2 give further information on the applicability of the sampling methods.

Table A.1 — Applicability of the sampling methods to different flue gas characteristics

Flue gas characteristics	Method A	Method B	Method C
Temperature, °C	< 800	< 800	< 800
H ₂ O content, g/m ³	< 600	< 500	< 300
Particulate matter concentration, g/m ³	< 5	< 2	< 2
PAH concentration, µg/nm ³	0,04 to 10 000	0,1 to 6 000 (0,002 5 µg/m ³)	0,002 to 30 000

Table A.2 — User information on the demonstrated applicability of the sampling methods

Process characteristics			Sampling method	
PAH concentration	Flue gas temperature °C	Source examples	Method	Comments
170 ng/nm ³ to 440 ng/nm ³	140	coal-fired AFBA	A	—
57 µg/nm ³ to 700 µg/nm ³	270 to 350	wood-burning installation	A	—
260 µg/m ³	885	waste oil incinerator	B	glass liner in sampling probe
7 µg/m ³	875	landfill gas incinerator	B	glass liner in sampling probe
4 µg/m ³	200	coal-fired power plant	B	glass liner in sampling probe
0,2 µg/m ³	200	pulp and paper mill recovery boiler	B	glass liner in sampling probe
70 µg/nm ³ to 360 µg/nm ³	300 to 400	marine diesel engine	B	XAD-2 cartridge
40 µg/nm ³	50 to 80	experimental boiler	B	PUF cartridge, 45 % H ₂ O
10 µg/nm ³ to 6 000 µg/nm ³	100 to 150	bark boiler	B	XAD-2 cartridge, high particles
< 0,5 µg/nm ³	100 to 150	lime kiln	B	XAD-2 cartridge, high particles
< 0,1 µg/nm ³ to 380 µg/nm ³	60 to 120	recovery boiler	B	XAD-2 cartridge, 25 % H ₂ O
1 to 6 600 µg/nm ³	100 to 200	waste incinerator	B	XAD-2 cartridge
< 0,01 µg/m ³	70 to 120	clean gas at MSWI	C	
0,03 µg/m ³ to 0,3 µg/m ³	200 to 300	raw gas at MSWI	C	
50 µg/m ³ to 500 µg/m ³	50 to 500	diesel engine exhaust	C	glass liner shall be included in work-up
200 µg/m ³ to 2 000 µg/m ³		coke oven	C	glass liner shall be included in work-up
0,2 µg/m ³ to 2 µg/m ³	200 to 350	raw gas electric-arc furnaces	C	
up to 30 000 µg/m ³		house heating	C	glass liner shall be included in work-up
0,2 µg/m ³ to 2 µg/m ³	450 to 500	landfill gas engines	C	

Annex B (informative)

Schematic representations, dimensions and materials of some tested sampling devices

B.1 Sampling devices

B.1.1 General

Sampling devices for all three methods shall include the following:

- a) a Prandtl or S-tube with a differential pressure gauge for measuring the static and dynamic pressures in the flue gas channel (for calculating the gas flowrate)

or

a micromanometer to determine the pressure in the stack, and
- b) a moisture-measuring device to determine the moisture in the flue gas, and
- c) an automated oxygen-measuring system to continuously determine the oxygen content, if oxygen correction is required, and
- d) a syringe to add the internal standard(s).

The material of which the sampling equipment is made should be inert towards PAH and easy to clean. Plastic gaskets should be avoided, since PAH can be adsorbed, and at high temperature compounds likely to interfere with the analysis are emitted.

If the sampling device is an all-glass one, ground-glass joints can be suitably sealed with a little clean water. Greases should never be used for this purpose. The sampling devices for Methods A, B and C are described in B.1.2, B.1.3 and B.1.4 respectively.

B.1.2 Sampling device for Method A: dilution method

In Figure B.1 a schematic presentation is provided of a sampling device of method A.

The sampling apparatus consists of:

B.1.2.1 Sampling probe orifice, of internal diameter of 8 mm to 30 mm depending on the suction output; made of corrosion-resistant material, e.g. borosilicate or quartz glass and stainless steel Material No. 14571, unalloyed titanium.

B.1.2.2 Elbow joint, made of corrosion-resistant material, e.g. stainless steel, unalloyed titanium.

B.1.2.3 Sampling probe, with internal tube made of corrosion-resistant material (e.g. titanium), heat output about 250 W to 1000 W per metre of tube length, insulated on the outside; heating controllable.

B.1.2.4 Two filter casings for mounting the glass fibre filter, one casing for the PAH sampling filter and one for the dilution air filter; made of corrosion-resistant materials, e.g. stainless steel. (For low-volatility PAHs, a combination casing is available as an option for mounting a solid adsorbent.)

B.1.2.5 **Mixing tube**, with an axial waste-gas inlet and a coaxial dilution-air feed.

B.1.2.6 **Two orifice meters**, for measuring the dilution air stream and the total gas stream (waste plus dilution air).

To calibrate the two flow measurement channels, the gas stream flowing through one orifice meter is first compared with the reading of a calibrated gas meter (2 % precision). In a second step the two flow measurement channels are connected in series in such a way that they carry both streams. The orifice meter constants are then matched. This differential gas stream measurement set-up achieves a precision of 2 % or better, based on the aspirated waste gas stream.

B.1.2.7 **Four thermoelements**, for measuring the temperatures in the suction tube, of the filter, of the dilution air and of the flue gas.

B.1.2.8 **Two PT-100 measurement sensors**, for measuring the temperature at the orifice meters.

B.1.2.9 **Three pressure gauges**, for measuring the effective pressure at the orifice meters and the pressure in the flue gas channel.

B.1.2.10 **Two differential pressure gauges**, for measuring the differential pressure at the orifice meter.

B.1.2.11 **Heat exchanger**, for cooling the dilution air (for an air throughput of 40 m³/h to 70 m³/h) required at outside temperature of > 25 °C.

B.1.2.12 **Drying tower**, packed with silica gel; for drying the dilution air (for an air throughput of 40 m³/h to 70 m³/h).

B.1.2.13 **Two automatic control valves**, motor-driven, with suitable flow-resistance characteristics.

B.1.2.14 **Suction device (ejector)**, or alternatively a vacuum pump or Roots blower.

B.1.2.15 **Compressed air**, for driving the ejector or the suction blower.

B.1.2.16 **Electric current connection**, for heating the suction tube and for the measuring equipment, fuse 2 × 20 V, 16 A.

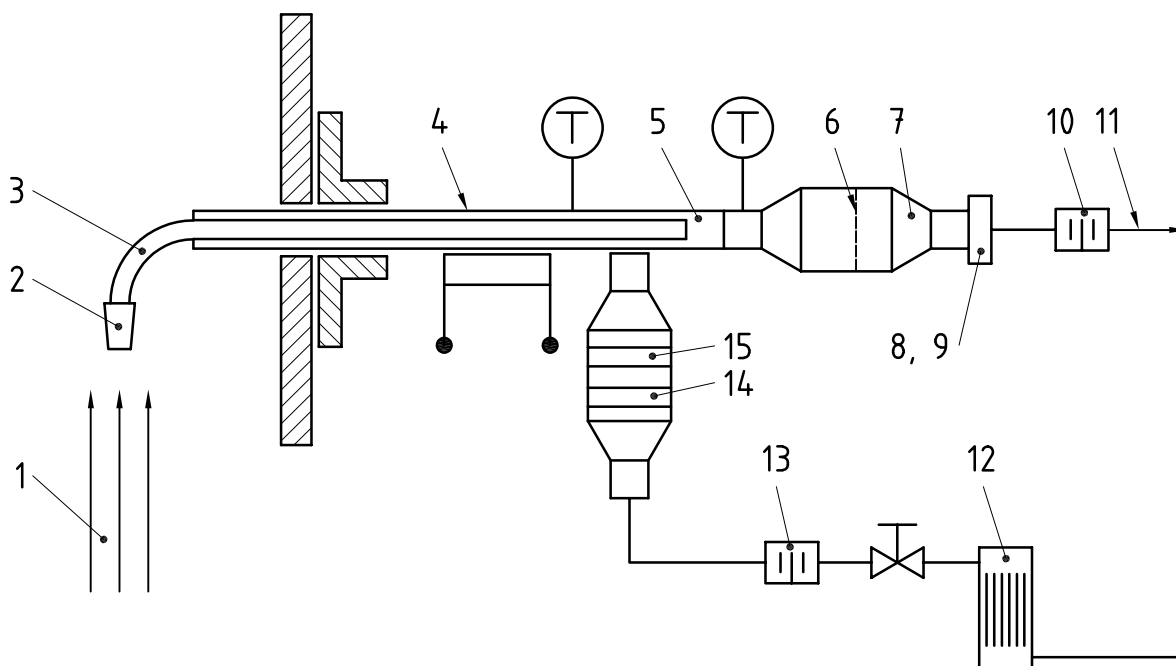

Key

- 1 off-gas
- 2 sampling probe
- 3 elbow joint
- 4 heated suction tube
- 5 mixing tube
- 6 sampling filter
- 7 compartment A
- 8 solid adsorber
- 9 compartment B
- 10 gas meter
- 11 to extractor
- 12 drying tower
- 13 gas meter
- 14 solid adsorber
- 15 cold air filter

Figure B.1 — Schematic representation of a sampling device for Method A

B.1.3 Sampling device for Method B: (Heated) filter/condenser/adsorber method

In Figures B.2 and B.3, schematic representations are provided of a sampling device for Method B (without and with flow division). Figure B.4 shows some particle filter types. In Figures B.5 and B.6, two types of condenser systems and adsorber cartridges are provided, respectively.

The sampling device consists of the following parts:

B.1.3.1 Sampling nozzle, made of titanium, quartz or glass, inside diameter 5 mm, 6 mm, 8 mm, 10 mm, 12 mm or 16 mm depending on the measurement application.

B.1.3.2 Elbow joint, made of titanium, quartz or glass.

B.1.3.3 Sampling probe, made of titanium, quartz or glass, heated with the temperature electronically controlled.

B.1.3.4 Filter casing, to collect the particles; made of titanium, glass or quartz. For some types of filter casings, see Figure B.4.

B.1.3.5 Oven, temperature electronically controlled.

The temperature of the filter on which the particles are collected should be the same as the flue gas. This can be achieved by mounting the filter in an oven outside the flue-gas current.

B.1.3.6 Quartz wool cartridge (optional), made of quartz or glass.

B.1.3.7 Cyclone (optional), made of glass; for use if there is a high particle content in the sample gas ($> 100 \text{ mg/m}^3$).

B.1.3.8 Flow divider (optional), to keep a ratio between main and side stream.

B.1.3.9 Glass tubes, to connect filter casing and condenser, e.g. supported with spherical joints and clamps.

B.1.3.10 Condenser, to reduce the sample gas temperature below $20 \text{ }^\circ\text{C}$.

B.1.3.11 Cooling aggregate, powered to at least 500 W , or **cooling water**.

B.1.3.12 Condensate flask, of sufficient volume to hold the condensate of the sampling period, e.g. a two-necked flask.

B.1.3.13 Impingers or wash bottles (alternatives for the condensate flask plus coolers).

The impingers or wash bottles are mounted without gas inlet tubes at the beginning and end of the train, in order to prevent any liquids from being sucked back into the equipment.

B.1.3.14 Solid adsorber, for capture of gaseous PAH, containing polyurethane foam (PUF) and/or XAD-2.

To prevent aerosols passing the adsorber, it may be preceded by a filter. The temperature of the adsorber should be kept at $< 20 \text{ }^\circ\text{C}$. To ensure adequate packing, the adsorber should be mounted vertically.

B.1.3.15 Drying tower, to dry the volume of the flue gas measured by the gas meter.

For this purpose a column of silica gel gives good results.

B.1.3.16 Two thermoelements, to measure the temperature of the sample gas, one behind the filter where the particles are collected and one in the solid adsorber.

B.1.3.17 Suction device with gas meter, pump and valve, to determine the sample volume and to regulate the volume flowrate, maintaining isokinetic conditions.

B.1.3.18 Connections, made of glass, quartz or titanium; behind the adsorber stage.

Plastic hoses are allowed.

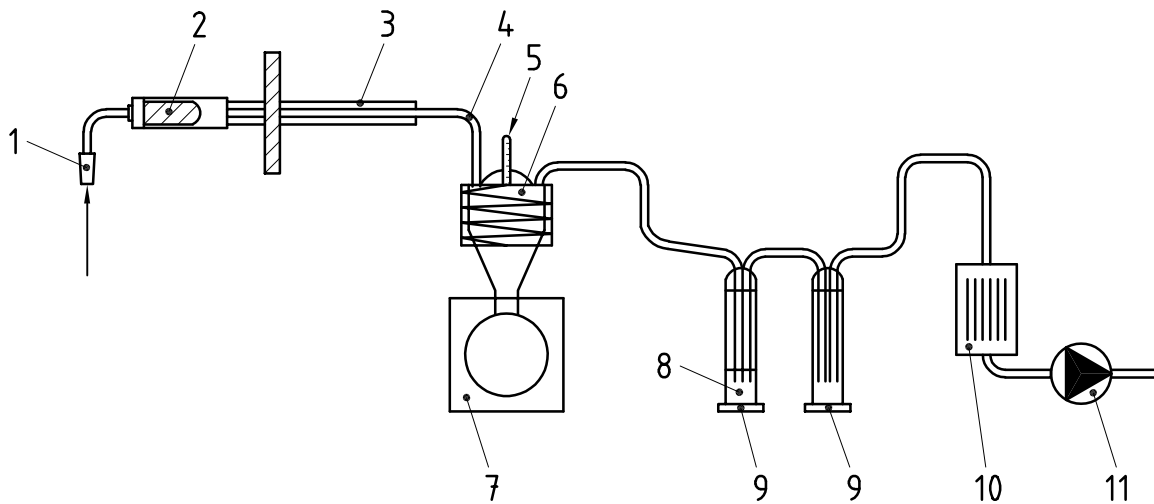

Key

- 1 nozzle
- 2 thimble filter
- 3 heated probe
- 4 connections (glass)
- 5 temperature control
- 6 condenser
- 7 condensate flask
- 8 diethylene glycol
- 9 bubbler
- 10 drying tower
- 11 suction device (pump, valve, gas meter)

Figure B.2 — Schematic representation of a sampling device for Method B (without flow division)

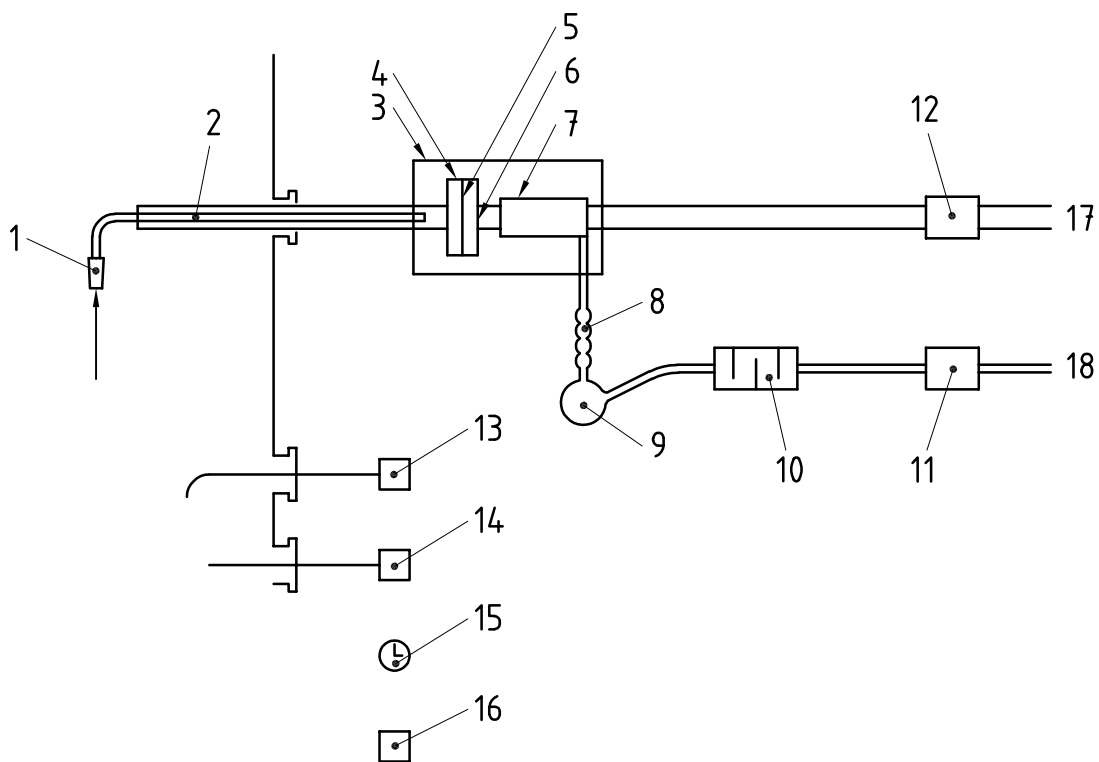

Key

- 1 sampling nozzle
- 2 probe (evenly heated)
- 3 temperature-regulated casing (box) ($T < 125\text{ }^{\circ}\text{C}$)
- 4 filter holder
- 5 filter (diameter 125 mm)
- 6 temperature control
- 7 flow divider
- 8 condenser
- 9 condensate bottle (1 litre)
- 10 solid adsorber and/or impinger unit
- 11 suction device, side stream max. 15 l/min
- 12 suction device, main stream max. 120 l/min
- 13 gas velocity and pressure meter
- 14 gas-temperature sensor
- 15 timer
- 16 atmospheric-pressure sensor
- 17 main stream
- 18 side stream

Figure B.3 — Schematic representation of a sampling device for Method B (with flow division)

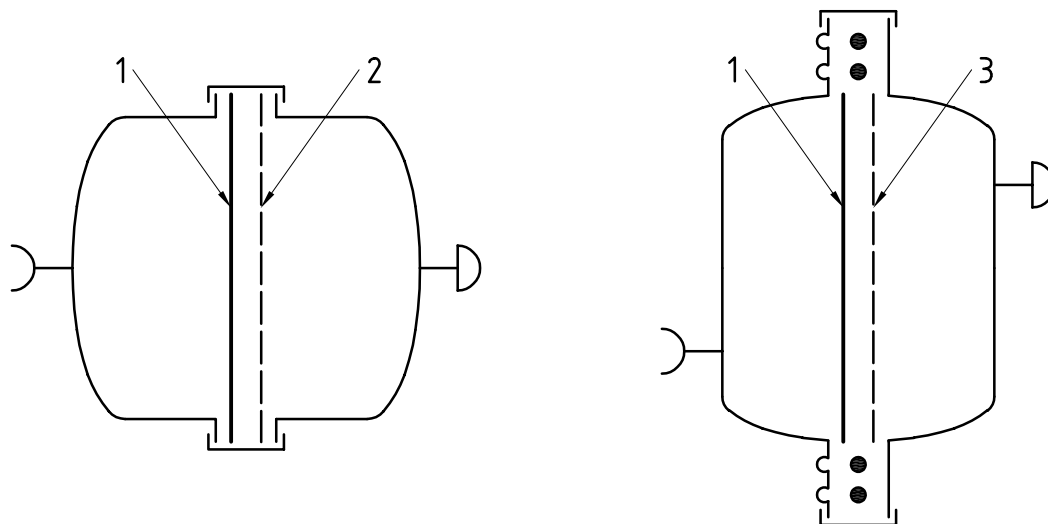

Key

- 1 filter (paper)
- 2 frit 60
- 3 non-corrosive gauze

Figure B.4 — Two types of particle filter

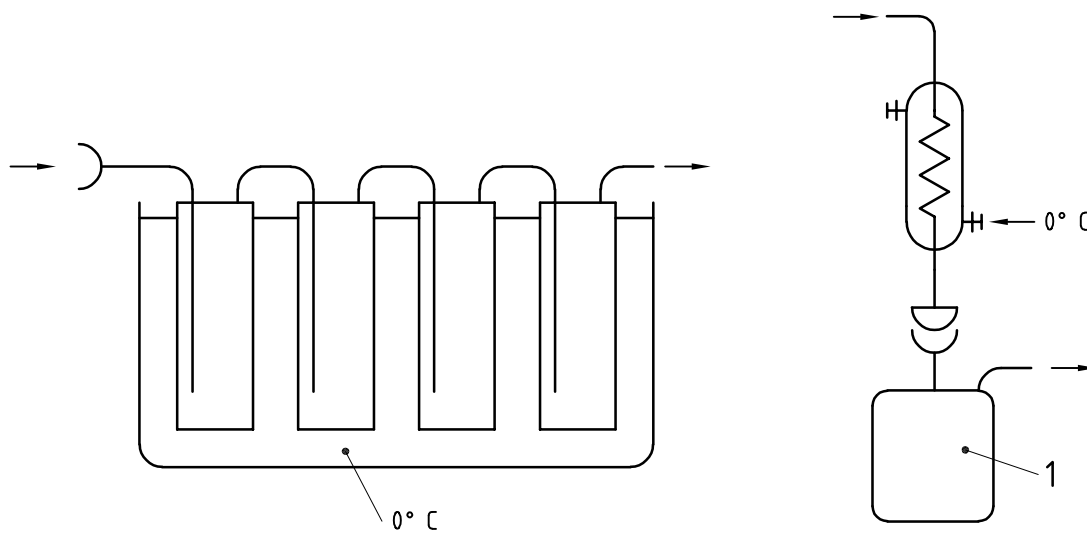

Key

- 1 condenser

Figure B.5 — Two types of condenser system

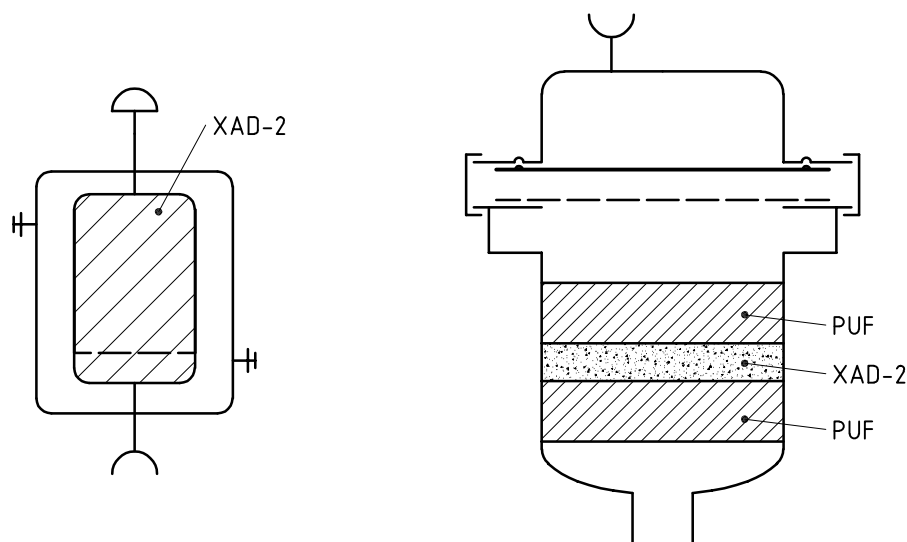

Figure B.6 — Two types of adsorber cartridge

B.1.4 Sampling device for Method C: Cooled probe/adsorber method

In Figure B.7 a schematic representation is provided of a sampling device for Method C. In Figure B.8 a representation of a cooled probe is given.

The sampling device consists of the following parts.

B.1.4.1 Sampling probe, made of titanium, quartz, glass or PTFE, inside diameter 5 mm, 6 mm, 8 mm, 10 mm, 12 mm or 16 mm according to the measurement task.

B.1.4.2 Elbow joint, made of titanium, quartz or glass.

B.1.4.3 Suction tube, water-cooled double-casting tube.

The inside tube shall be made of titanium, glass or quartz. If the inside tube is to be cut into pieces after sampling to clean it in the laboratory, this tube shall be tightened by means of a gland (stuff box).

B.1.4.4 Support, to fix the suction tube to the stack by quick snaps to enable removal of the complete sampling device for cross-sectional measurements.

B.1.4.5 Quartz wool cartridge or cyclone, to sample the particles.

B.1.4.6 Thermoelement, to measure the temperature of the sample gas behind the suction tube.

B.1.4.7 Condensate bottle, made of brown glass (e.g. with ground joints, three-necked) of sufficient volume to hold the condensate from the sampling period.

B.1.4.8 Solid adsorber cartridge, downstream, with a glass frit of porosity P250 in accordance with ISO 4793.

B.1.4.9 Filter casing, to keep the plane filter at 0,3 µm with supporting net.

B.1.4.10 Drying tower filled with moisture-adsorbing material, e.g. silica.

B.1.4.11 Suction device with gas meter, pump and valve, to determine the sample volume and to regulate the volume flowrate, maintaining isokinetic conditions.

B.1.4.12 Impinger inserted into the condensate bottle, optional alternative to the cooled suction tube and condensate bottle.

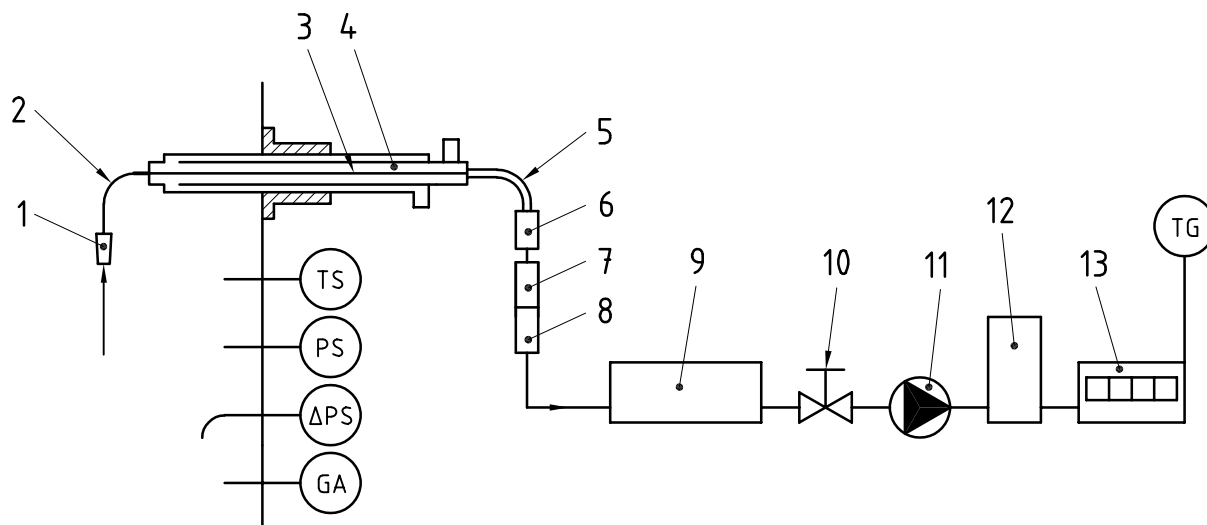

Key

- 1 nozzle
 - 2 elbow
 - 3 glass tube
 - 4 cooled suction tube
 - 5 glass connection
 - 6 condensate bottle
 - 7 quartz wool filter
 - 8 XAD-2 resin
 - 9 cooler for measuring gas
 - 10 regulation valve
 - 11 pump
 - 12 silica gel drying tower
 - 13 gas meter
- TG temperature measurement at the gas meter
 TS temperature measurement inside the stack
 PS pressure measurement inside the stack
 ΔPS balance pressure inside the stack (dynamic)
 GA flue gas analyser (CO₂ + O₂)

Figure B.7 — Schematic representation of sampling device for Method C

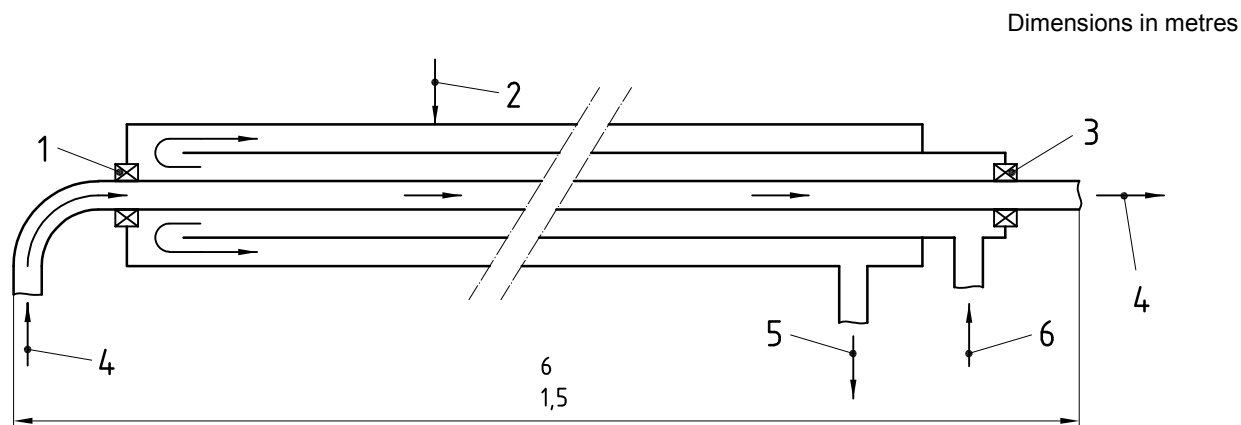
**Key**

- 1 stuff box
- 2 titanium
- 3 stuff box
- 4 sample gas
- 5 outlet, cooling fluid
- 6 inlet, cooling fluid

Figure B.8 — Example of a cooled probe

B.2 Reagents and materials

Due to possible interferences during the analysis, unless otherwise stated, use only reagents of recognized analytical grade and of purity as described, and only distilled water or water of equivalent purity.

The solvents used shall be free of chemical-blank values.

B.2.1 Cooling fluid, to cool the condenser or the cooled suction tube.

B.2.2 Ice bath, to cool the impingers.

B.2.3 Silica gel, for the drying tower for drying the dilution air (Method A).

B.2.4 Cooling water, for cooling the dilution air (at temperatures > 25 °C) (Method A).

B.2.5 Acetone, for cleaning the sampling apparatus.

B.2.6 Methanol, for cleaning the sampling apparatus.

B.2.7 Toluene, for cleaning the sampling apparatus.

B.2.8 (M)ethoxyethanol, as impinger fluid.

B.2.9 Distilled water.

B.2.10 Glass fibre filter (Method A), e.g. micron filter WB 50 as an exchange filter without reinforcing rings.

The filters are impregnated with 5 g of liquid paraffin: degree of separation 99,98 % for particles of 0,3 µm to 0,5 µm; filter area about 1 m².

B.2.11 Glass fibre filter (Method B or C), lined with PTFE, porosity 0,3 µm (cutting diameter; efficiency 99,9 %); sized according to the size of the filter casing.

B.2.12 Quartz wool (if used).

Quartz wool filters, if used, shall be extracted with toluene and shall be dried before use.

B.2.13 Solid adsorber (if used).

B.2.13.1 Polyurethane foam (PUF) (with open cells) with a density ranging from 20 kg/m³ to 25 kg/m³ and a porosity equivalent to a back-pressure of 20 kPa.

The PUF plugs are cut from foam disks to form a cylinder of appropriate size and are purified as follows.

Boil for 2 h to 3 h successively in the following solvents: methanol, methylene chloride, toluene, acetone. Squeeze out the acetone, spread out on an aluminium sheet and allow to dry, preferably overnight in a vacuum drying oven at 40 °C.

Store the purified PUF plugs, without compression, in brown glass bottles.

B.2.13.2 XAD-2 porous polymer.

Purify the XAD-2 (0,3 mm to 1 mm granule size) by first successively washing several times with water, methanol and methylene chloride until the filtrates are no longer turbid. Then extract the XAD-2 in a Soxhlet apparatus (or accelerated solvent extractor) with toluene for at least 48 h, the extractant being renewed several times. Then wash the XAD-2 with methylene chloride and remove the residual methylene chloride in a rotary evaporator under controlled vacuum (500 hPa, bath temperature 40 °C).

Store the XAD-2 polymer purified in this way in a glass bottle with a gas-tight screwcap.

B.2.13.3 Porapak PS.

Extract the Porapak PS (50 mesh to 80 mesh) in a Soxhlet apparatus first with acetonitrile for 8 h, then with benzene for 4 h and finally with methylene chloride for 4 h. Then dry for 3 h at 80 °C.

Store the dried material in glass bottles with ground-joint stoppers. Distil twice before use each solvent used for the extraction.

B.3 Internal standards

Prior to sampling, spike the sampler with a known amount of internal standard. For the different stages in the sampling equipment (filter, adsorber, impingers) different internal standards can be used.

Bibliography

- [1] ISO 4226:1993, *Air quality — General aspects — Units of measurement*
- [2] ISO 4793, *Laboratory sintered (fritted) filters — Porosity grading, classification and designation*
- [3] ISO 6879, *Air quality — Performance characteristics and related concepts for air quality measuring methods*
- [4] ISO 11338-2, *Stationary source emissions — Determination of gas and particle-phase polycyclic aromatic hydrocarbons — Part 2: Sample preparation, clean-up and determination*

BSI — British Standards Institution

BSI is the independent national body responsible for preparing British Standards. It presents the UK view on standards in Europe and at the international level. It is incorporated by Royal Charter.

Revisions

British Standards are updated by amendment or revision. Users of British Standards should make sure that they possess the latest amendments or editions.

It is the constant aim of BSI to improve the quality of our products and services. We would be grateful if anyone finding an inaccuracy or ambiguity while using this British Standard would inform the Secretary of the technical committee responsible, the identity of which can be found on the inside front cover.
Tel: +44 (0)20 8996 9000. Fax: +44 (0)20 8996 7400.

BSI offers members an individual updating service called PLUS which ensures that subscribers automatically receive the latest editions of standards.

Buying standards

Orders for all BSI, international and foreign standards publications should be addressed to Customer Services. Tel: +44 (0)20 8996 9001.
Fax: +44 (0)20 8996 7001. Email: orders@bsi-global.com. Standards are also available from the BSI website at <http://www.bsi-global.com>.

In response to orders for international standards, it is BSI policy to supply the BSI implementation of those that have been published as British Standards, unless otherwise requested.

Information on standards

BSI provides a wide range of information on national, European and international standards through its Library and its Technical Help to Exporters Service. Various BSI electronic information services are also available which give details on all its products and services. Contact the Information Centre.
Tel: +44 (0)20 8996 7111. Fax: +44 (0)20 8996 7048. Email: info@bsi-global.com.

Subscribing members of BSI are kept up to date with standards developments and receive substantial discounts on the purchase price of standards. For details of these and other benefits contact Membership Administration.
Tel: +44 (0)20 8996 7002. Fax: +44 (0)20 8996 7001.
Email: membership@bsi-global.com.

Information regarding online access to British Standards via British Standards Online can be found at <http://www.bsi-global.com/bsonline>.

Further information about BSI is available on the BSI website at <http://www.bsi-global.com>.

Copyright

Copyright subsists in all BSI publications. BSI also holds the copyright, in the UK, of the publications of the international standardization bodies. Except as permitted under the Copyright, Designs and Patents Act 1988 no extract may be reproduced, stored in a retrieval system or transmitted in any form or by any means – electronic, photocopying, recording or otherwise – without prior written permission from BSI.

This does not preclude the free use, in the course of implementing the standard, of necessary details such as symbols, and size, type or grade designations. If these details are to be used for any other purpose than implementation then the prior written permission of BSI must be obtained.

Details and advice can be obtained from the Copyright & Licensing Manager.
Tel: +44 (0)20 8996 7070. Fax: +44 (0)20 8996 7553.
Email: copyright@bsi-global.com.