

# Soil quality — Determination of particle size distribution in mineral soil material — Method by sieving and sedimentation

ICS 13.080.20

## National foreword

This British Standard is the UK implementation of ISO 11277:2009. It supersedes BS 7755-5.4:1998 which is withdrawn.

The UK participation in its preparation was entrusted to Technical Committee EH/4, Soil quality.

A list of organizations represented on this committee can be obtained on request to its secretary.

This publication does not purport to include all the necessary provisions of a contract. Users are responsible for its correct application.

**Compliance with a British Standard cannot confer immunity from legal obligations.**

This British Standard was published under the authority of the Standards Policy and Strategy Committee on 30 April 2010

© BSI 2010

ISBN 978 0 580 67636 9

### Amendments/corrigenda issued since publication

Date	Comments

INTERNATIONAL  
STANDARD

BS ISO 11277:2009

**ISO**  
**11277**

Second edition  
2009-09-15

---

---

**Soil quality — Determination of particle  
size distribution in mineral soil  
material — Method by sieving and  
sedimentation**

*Qualité du sol — Détermination de la répartition granulométrique de la  
matière minérale des sols — Méthode par tamisage et sédimentation*



Reference number  
ISO 11277:2009(E)

© ISO 2009

**PDF disclaimer**

This PDF file may contain embedded typefaces. In accordance with Adobe's licensing policy, this file may be printed or viewed but shall not be edited unless the typefaces which are embedded are licensed to and installed on the computer performing the editing. In downloading this file, parties accept therein the responsibility of not infringing Adobe's licensing policy. The ISO Central Secretariat accepts no liability in this area.

Adobe is a trademark of Adobe Systems Incorporated.

Details of the software products used to create this PDF file can be found in the General Info relative to the file; the PDF-creation parameters were optimized for printing. Every care has been taken to ensure that the file is suitable for use by ISO member bodies. In the unlikely event that a problem relating to it is found, please inform the Central Secretariat at the address given below.



**COPYRIGHT PROTECTED DOCUMENT**

© ISO 2009

All rights reserved. Unless otherwise specified, no part of this publication may be reproduced or utilized in any form or by any means, electronic or mechanical, including photocopying and microfilm, without permission in writing from either ISO at the address below or ISO's member body in the country of the requester.

ISO copyright office  
Case postale 56 • CH-1211 Geneva 20  
Tel. + 41 22 749 01 11  
Fax + 41 22 749 09 47  
E-mail [copyright@iso.org](mailto:copyright@iso.org)  
Web [www.iso.org](http://www.iso.org)

Published in Switzerland

## Contents

Page

<b>Foreword</b> .....	<b>iv</b>
<b>Introduction</b> .....	<b>v</b>
<b>1 Scope</b> .....	<b>1</b>
<b>2 Normative references</b> .....	<b>1</b>
<b>3 Terminology and symbols</b> .....	<b>2</b>
<b>4 Principle</b> .....	<b>2</b>
<b>5 Field sampling</b> .....	<b>4</b>
<b>6 Sample preparation</b> .....	<b>4</b>
<b>7 Dry sieving (material &gt; 2 mm)</b> .....	<b>4</b>
<b>8 Wet sieving and sedimentation (material &lt; 2 mm)</b> .....	<b>7</b>
<b>9 Precision</b> .....	<b>20</b>
<b>10 Test report</b> .....	<b>21</b>
<b>Annex A (normative) Determination of particle size distribution of mineral soil material that is not dried prior to analysis</b> .....	<b>22</b>
<b>Annex B (normative) Determination of particle size distribution of mineral soils by a hydrometer method following destruction of organic matter</b> .....	<b>25</b>
<b>Bibliography</b> .....	<b>34</b>

## Foreword

ISO (the International Organization for Standardization) is a worldwide federation of national standards bodies (ISO member bodies). The work of preparing International Standards is normally carried out through ISO technical committees. Each member body interested in a subject for which a technical committee has been established has the right to be represented on that committee. International organizations, governmental and non-governmental, in liaison with ISO, also take part in the work. ISO collaborates closely with the International Electrotechnical Commission (IEC) on all matters of electrotechnical standardization.

International Standards are drafted in accordance with the rules given in the ISO/IEC Directives, Part 2.

The main task of technical committees is to prepare International Standards. Draft International Standards adopted by the technical committees are circulated to the member bodies for voting. Publication as an International Standard requires approval by at least 75 % of the member bodies casting a vote.

Attention is drawn to the possibility that some of the elements of this document may be the subject of patent rights. ISO shall not be held responsible for identifying any or all such patent rights.

ISO 11277 was prepared by Technical Committee ISO/TC 190, *Soil quality*.

This second edition cancels and replaces the first edition (ISO 11277:1998), of which it constitutes a minor revision, and incorporates ISO 11277:1998/Cor.1:2002.

## Introduction

The physical and chemical behaviour of soils is controlled in part by the amounts of mineral particles of different sizes in the soil. The subject of this International Standard is the quantitative measurement of such amounts (expressed as a proportion or percentage of the total mass of the mineral soil), within stated size classes.

The determination of particle size distribution is affected by organic matter, soluble salts, cementing agents (especially iron compounds), relatively insoluble substances such as carbonates and sulfates, or combinations of these. Some soils change their behaviour to such a degree, upon drying, that the particle size distribution of the dried material bears little or no relation to that of the undried material encountered under natural conditions. This is particularly true of soils rich in organic matter, those developed from recent volcanic deposits, some highly weathered tropical soils, and soils often described as “cohesive” (Reference [3] in the Bibliography). Other soils, such as the so-called “sub-plastic” soils of Australia, show little or no tendency to disperse under normal laboratory treatments, despite field evidence of a large clay content.

The procedures given in this International Standard recognize these kinds of differences between soils from different environments, and the methodology presented is designed to deal with them in a structured manner. Such differences in soil behaviour can be very important, but awareness of them depends usually on local knowledge. Given that the laboratory is commonly distant from the site of the field operation, the information supplied by field teams becomes crucial to the choice of an appropriate laboratory procedure. This choice can be made only if the laboratory is made fully aware of this background information.





# Soil quality — Determination of particle size distribution in mineral soil material — Method by sieving and sedimentation

**WARNING** — All procedures in this International Standard must be carried out by competent, trained persons, with adequate supervision. Attention is drawn to certain known hazards, but it is essential that users follow safe working practices. If in any doubt, seek professional advice.

It is essential that users of this International Standard read all of it before commencing any operation, as failure to note certain points will lead to incorrect analysis and could be dangerous.

## 1 Scope

This International Standard specifies a basic method of determining the particle size distribution applicable to a wide range of mineral soil materials, including the mineral fraction of organic soils. It also offers procedures to deal with the less common soils mentioned in the introduction. This International Standard has been developed largely for use in the field of environmental science, and its use in geotechnical investigations is something for which professional advice might be required.

A major objective of this International Standard is the determination of enough size fractions to enable the construction of a reliable particle-size-distribution curve.

This International Standard does not apply to the determination of the particle size distribution of the organic components of soil, i.e. the more or less fragile, partially decomposed, remains of plants and animals. It is also realized that the chemical pretreatments and mechanical handling stages in this International Standard could cause disintegration of weakly cohesive particles that, from field inspection, might be regarded as primary particles, even though such primary particles could be better described as aggregates. If such disintegration is undesirable, then this International Standard is not used for the determination of the particle size distribution of such weakly cohesive materials.

## 2 Normative references

The following referenced documents are indispensable for the application of this document. For dated references, only the edition cited applies. For undated references, the latest edition of the referenced document (including any amendments) applies.

ISO 565:1990, *Test sieves — Metal wire cloth, perforated metal plate and electroformed sheet — Nominal sizes of openings*

ISO 3310-1:2000, *Test sieves — Technical requirements and testing — Part 1: Test sieves of metal wire cloth*

ISO 3310-2:1999, *Test sieves — Technical requirements and testing — Part 2: Test sieves of perforated metal plate*

ISO 3696:1987, *Water for analytical laboratory use — Specification and test methods*

ISO 11464:2006, *Soil quality — Pretreatment of samples for physico-chemical analysis*

### 3 Terminology and symbols

#### 3.1 Terminology

Particles within particular size ranges or classes are commonly described as cobbles, gravel, coarse sand, silt, etc. The meaning of such trivial names differs between countries, and in some cases there are no exact translations of such words from one language to another; for example, the Dutch word “zavel” has no equivalent in English. The only fraction for which there appears to be common agreement is clay, which is defined as material of less than 0,002 mm equivalent spherical diameter (References [1, 3] in the Bibliography). Such trivial names shall not be used in describing the results of particle size determination according to this International Standard. Phrases such as “... passing a 20 mm aperture sieve ...” or “... less than 0,063 mm equivalent spherical diameter ...” shall be used instead. If trivial names must be used, for example, to cross-reference to another International or National Standard, then the trivial name should be defined explicitly, so as to remove any doubt as to the meaning intended, e.g. silt (0,063 mm to 0,002 mm equivalent spherical diameter) (see Clause 4). Furthermore, it is common to use the word “texture” to describe the results of particle-size-distribution measurements, e.g. “the particle size of this soil is of clay texture”. This is incorrect as the two concepts are different, and the word “texture” shall not be used in the test report (Clause 10) to describe the results obtained by the use of this International Standard.

It is common to refer to sieves as having a particular mesh-size or mesh number. These are not the same as the sieve aperture, and the relationship between the various numbers is not immediately obvious. The use of mesh numbers as a measurement of particle size is difficult to justify, and shall not be used in reporting the results of this International Standard.

#### 3.2 Symbols

The following symbols are found throughout the text and, where appropriate, units and quantities are as given below (the SI convention is followed for common units, e.g. g = gram; m = metre; mm = millimetre; s = second, etc.).

Mg megagram ( $10^6$  g);

mPa millipascal;

$t$  is the settling time, in seconds, of a particle of diameter  $d_p$ ;

$\eta$  is the dynamic viscosity of water at the test temperature (see Table B.2), in millipascals per second;

$h$  is the sampling depth, in centimetres;

$\rho_s$  is the mean particle density, in megagrams per cubic metre (taken as  $2,65 \text{ Mg/m}^3$ ; see the note in Clause 4);

$\rho_w$  is the density of the liquid containing the soil suspension, in megagrams per cubic metre (taken as  $1,00 \text{ Mg/m}^3$ ; see the note in Clause 4);

$g$  is the acceleration due to gravity, in centimetres per second squared (taken as  $981 \text{ cm/s}^2$ );

$d_p$  is the equivalent spherical diameter of the particle of interest, in millimetres.

### 4 Principle

The particle size distribution is determined by a combination of sieving and sedimentation, starting from air-dried soil (Reference [3] in the Bibliography) (see note below). A method for undried soil is given in Annex A. Particles not passing a 2 mm aperture sieve are determined by dry sieving. Particles passing such a sieve, but retained on a 0,063 mm aperture sieve, are determined by a combination of wet and dry sieving, whilst

particles passing the latter sieve are determined by sedimentation. The pipette method is preferred. A hydrometer method is given in Annex B. A combination of sieving and sedimentation enables the construction of a continuous particle-size-distribution curve.

The key points in this procedure are summarized as a flow chart in Figure 2. This International Standard requires that the proportions of fractions separated by sedimentation and sieving be determined from the masses of such fractions obtained by weighing. Other methods of determining the mass of such fractions rely on such things as the interaction of particles with electromagnetic radiation or electrical fields (Reference [1] in the Bibliography). There are often considerable difficulties in relating the values obtained by these different methods for the same sample. It is one of the intentions of this International Standard that close adherence to its details should help minimize interlaboratory variation in the determination of the particle size distribution of mineral soils. Therefore, the proportions of fractions shall be determined only by weighing. If this is not the method used, then compliance with this International Standard cannot be claimed in the test report (Clause 10).

Both the pipette and hydrometer methods assume that the settling of particles in the sedimentation cylinder is in accordance with Stokes's Law (References [1, 3, 6] in the Bibliography), and the constraints that this implies, namely:

- a) the particles are rigid, smooth spheres;
- b) the particles settle in laminar flow, i.e. the Reynolds Number is less than about 0,2; this constraint sets an upper equivalent spherical particle diameter (see below) slightly greater than 0,06 mm for Stokesian settling under gravity (Reference [1] in the Bibliography);
- c) the suspension of particles is sufficiently dilute to ensure that no particle interferes with the settling of any other particle;
- d) there is no interaction between the particle and fluid;
- e) the diameter of the suspension column is large compared to the diameter of the particle, i.e. the fluid is of "infinite extent";
- f) the particle has reached its terminal velocity;
- g) the particles are of the same relative density.

Thus, the diameter of a particle is defined in terms of the diameter of a sphere whose behaviour in suspension matches that of the particle. This is the concept of *equivalent spherical diameter*. It is the principle upon which the expression of the diameter of particles, as derived from sedimentation, is based in this International Standard.

Stokes's Law can be written, for the purposes of this International Standard, in the form:

$$t = 18\eta h / [(\rho_s - \rho_w)gd_p^2]$$

where

- $t$  is the settling time, in seconds, of a particle of diameter  $d_p$  (see below);
- $\eta$  is the dynamic viscosity of water at the test temperature (see Table B.2), in millipascals per second;
- $h$  is the sampling depth, in centimetres;
- $\rho_s$  is the mean particle density, in megagrams per cubic metre (taken as 2,65 Mg/m<sup>3</sup>; see note);
- $\rho_w$  is the density of the liquid containing the soil suspension, in megagrams per cubic metre (taken as 1,00 Mg/m<sup>3</sup>; see note);

$g$  is the acceleration due to gravity, in centimetres per second squared (taken as 981 cm/s<sup>2</sup>);

$d_p$  is the equivalent spherical diameter of the particle of interest, in millimetres.

**NOTE** It is realized that there are considerable differences between the densities of soil particles, but for the purposes of this International Standard it is assumed that the mean particle density is that of quartz, i.e. 2,65 Mg/m<sup>3</sup> (Reference [7] in the Bibliography), as this is the commonest mineral in a very wide range of soils. The density of water is 0,998 2 Mg/m<sup>3</sup> and 0,995 6 Mg/m<sup>3</sup> at 20 °C and 30 °C, respectively (Reference [5] in the Bibliography). Given the effect of the addition of a small amount of dispersant (see 8.3.2), the density of water is taken as 1,000 0 Mg/m<sup>3</sup> over the permitted temperature range of this International Standard (8.2.2).

Furthermore, for routine use, it is recommended that the sampling times be converted to minutes and/or hours, as appropriate, to lessen the risk of error (see Table 3).

## 5 Field sampling

The mass of sample taken in the field shall be representative of the particle size distribution, especially if the amount of the larger particles is to be determined reliably. Table 1 gives recommended minimum masses.

## 6 Sample preparation

Samples shall be prepared in accordance with the methods given in ISO 11464.

**NOTE** For many purposes, particle size distribution is determined only for the fraction of the soil passing a 2 mm aperture sieve. In this case, the test sample (8.5) can be taken either according to the procedures in ISO 11464 or from the material passing a 2 mm aperture sieve according to 7.2.

## 7 Dry sieving (material > 2 mm)

### 7.1 General

The procedure specified in this clause applies to material retained on a 2 mm aperture sieve. Table 2 gives the maximum mass which shall be retained on sieves of different diameters and apertures. If more than this amount of material is retained, then it shall be subdivided appropriately and resieved.

### 7.2 Apparatus

**7.2.1 Test sieves**, with apertures which comply with ISO 565, and with well-fitting covers and receivers.

The full range of sieves appropriate to the largest particle(s) present should be used (see Table 1 and 7.2.3). The apertures chosen shall be stated in the test report (Clause 10). The accuracy of the sieves shall be verified monthly against a set of master sieves kept for this purpose, using an accepted method such as particle reference materials, microscopy, etc. (Reference [1] in the Bibliography) depending on the sieve aperture. Tolerances shall meet the requirements of ISO 3310-1 and ISO 3310-2. Sieves that do not meet these specifications shall be discarded. A record shall be kept of such testing.

Brass sieves are particularly liable to splitting and distortion, and steel sieves are strongly recommended for the larger apertures.

Special care shall be taken to ensure that covers and receivers do not leak. Sieves shall be inspected weekly when in regular use, and on every occasion if used less often. A record shall be kept of such inspections. Round-hole sieves shall not be used.

**7.2.2 Balance**, capable of weighing to an accuracy of within  $\pm 0,5$  g.

**7.2.3 Mechanical sieve shaker.**

It is usually impracticable to sieve mechanically at sieve apertures much greater than 20 mm, unless very heavy-duty equipment is available. Mechanical sieve shaking is essential to sieve efficiency at smaller apertures.

**7.2.4 A sieve brush and a stiff brush.**

### 7.3 Procedure

Weigh the dry test sample, prepared in accordance with ISO 11464, to the nearest 0,5 g ( $m_1$ ). Place the weighed material on the 20 mm sieve, and by brushing the material gently over the sieve apertures with the stiff brush (to remove any adhering soil), sieve the material. Take care not to detach any fragments from the primary particles. Sieve the retained material on the nest of sieves of selected apertures (7.2.1) and record the amount retained on each sieve to the nearest 0,5 g. Do not overload the sieves (see Table 1), but sieve the material in portions if necessary.

Weigh the material passing the 20 mm aperture sieve ( $m_2$ ), or a suitable portion of it ( $m_3$ ) (see Table 2) obtained by an appropriate subsampling method (see Clause 6), and place this on a nest of sieves, the lowermost having an aperture of 2 mm. Shake the sieves mechanically until no further material passes any of the sieves (see note). Record the mass of material retained on each sieve and the mass passing the 2 mm aperture sieve.

The total mass of the fractions should be within 1 % of  $m_2$  or  $m_3$ , as appropriate. If it is not, then check for sieve damage and discard sieves as appropriate (see 7.2.1).

The sieve equipment performance should be verified against a suitable test material, e.g. standard particle reference materials, ballotini, at intervals of one month. The results of this check shall be recorded.

**NOTE** For practical purposes, it is usual to choose a standard sieve shaking time which gives an acceptable degree of sieving efficiency with a wide range of soil materials. The minimum recommended period is 10 min.

**Table 1 — Mass of soil sample to be taken for sieving**

Maximum size of material forming > 10 % of the soil (given as test sieve aperture, in mm)	Minimum mass of sample to be taken for sieving kg
63	50
50	35
37,5	15
28	6
20	2
14	1
10	0,5
6,3	0,5
5	0,2
2 or smaller	0,1

**Table 2 — Maximum mass of material to be retained on each test sieve at the completion of sieving**

Test sieve aperture mm	Maximum mass kg		
	Sieve diameter mm		
	450	300	200
50	10	4,5	
37,5	8	3,5	
28	6	2,5	
20	4	2,0	
14	3	1,5	
10	2	1,0	
6,3	1,5	0,75	
5	1,0	0,5	
3,35			0,3
2			0,2
1,18			0,1
0,6			0,075
0,425			0,075
0,3			0,05
0,212			0,05
0,15			0,04
0,063			0,025

#### 7.4 Calculation and expression of results

For the material retained by the 20 mm and larger aperture sieves, calculate the proportion by mass retained by each sieve as a proportion of  $m_1$ . For example:

$$\text{Proportion retained on the 20 mm sieve} = [m(20 \text{ mm})]/m_1$$

For the material passing the 20 mm sieve, multiply the mass of material passing each sieve by  $m_2/m_3$  and calculate this as a proportion of  $m_1$ . For example:

$$\text{Proportion retained on the 6,3 mm sieve} = m(6,3 \text{ mm})[(m_2/m_3)/m_1]$$

Present the results as a table showing, to two significant figures, the proportion by mass retained on each sieve and the proportion passing the 2 mm sieve. The data shall also be used to construct a cumulative distribution curve (see Figure 1).

## 8 Wet sieving and sedimentation (material < 2 mm)

### 8.1 General

This clause specifies the procedure (see Figure 2) for the determination of the particle size distribution of the material passing the 2 mm aperture sieve down to < 0,002 mm equivalent spherical diameter (see note). In order to ensure that primary particles, rather than loosely bonded aggregates, are measured, organic matter and salts are removed, especially sparingly soluble salts such as gypsum which would otherwise prevent dispersion and/or promote flocculation of the finer soil particles in suspension (see 8.6), and a dispersing agent is added (8.8). These procedures are required in this International Standard, and their omission shall invalidate its application. Sometimes iron oxides and carbonates, especially of calcium and/or magnesium, are also removed. Preferred procedures for the removal of these compounds are given in the note in 8.7. The removal of any compound shall be recorded in the test report (Clause 10).

**NOTE** Gravitational sedimentation can give a value for the total amount of material < 0,002 mm equivalent spherical diameter. However, the method cannot be used to divide this class further with reliability, as particles less than about 0,001 mm equivalent spherical diameter can be kept in suspension almost indefinitely by Brownian motion (Reference [1] in the Bibliography).

### 8.2 Apparatus

The apparatus specified hereafter is sufficient to deal with one sample. Clearly it is more efficient to work in batches. Experience has shown (Reference [6] in the Bibliography) that one operator can process up to 36 samples in a batch at a time, given sufficient apparatus and space, especially if calculations are dealt with by a computer.

**8.2.1 Sampling pipette**, of a pattern similar to that shown in Figure 3, the chief requirement being that the smallest practicable zone of sedimenting suspension shall be sampled. The pipette shall be of not less than 10 ml volume and shall be held in a frame so that it can be lowered to a fixed depth within a sedimentation tube (see Figure 4).

**NOTE** Experience suggests that a pipette with an upper volume of 50 ml is more than sufficient for most purposes. A 25 ml volume pipette is a convenient compromise for routine analysis, but a smaller volume pipette will be found to be sufficient for soils with down to about 10 % mass fraction of < 0,063 mm equivalent spherical diameter. Below this amount, greater precision is likely to be obtained with a pipette of larger volume.

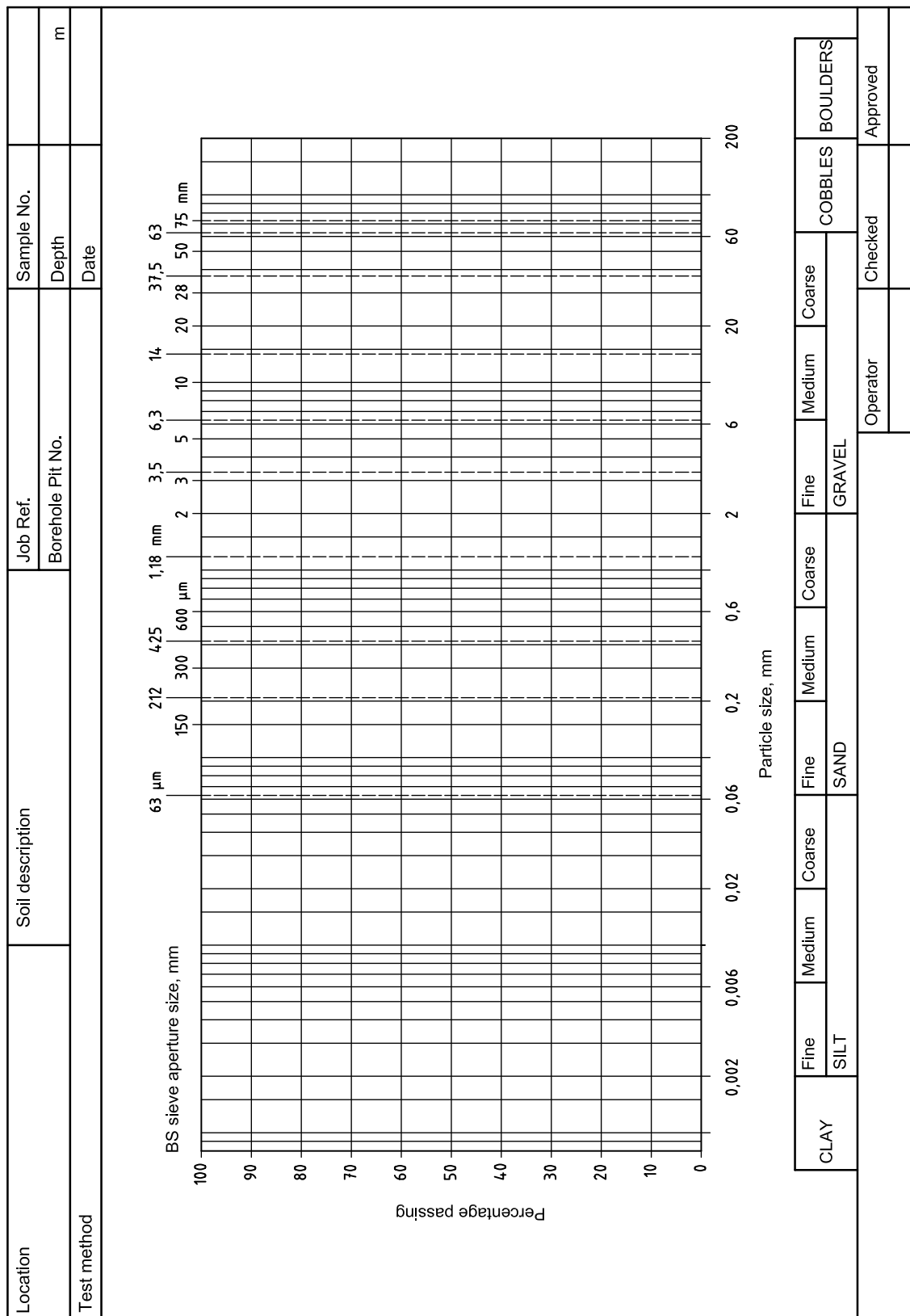

Figure 1 — Particle-size-distribution chart



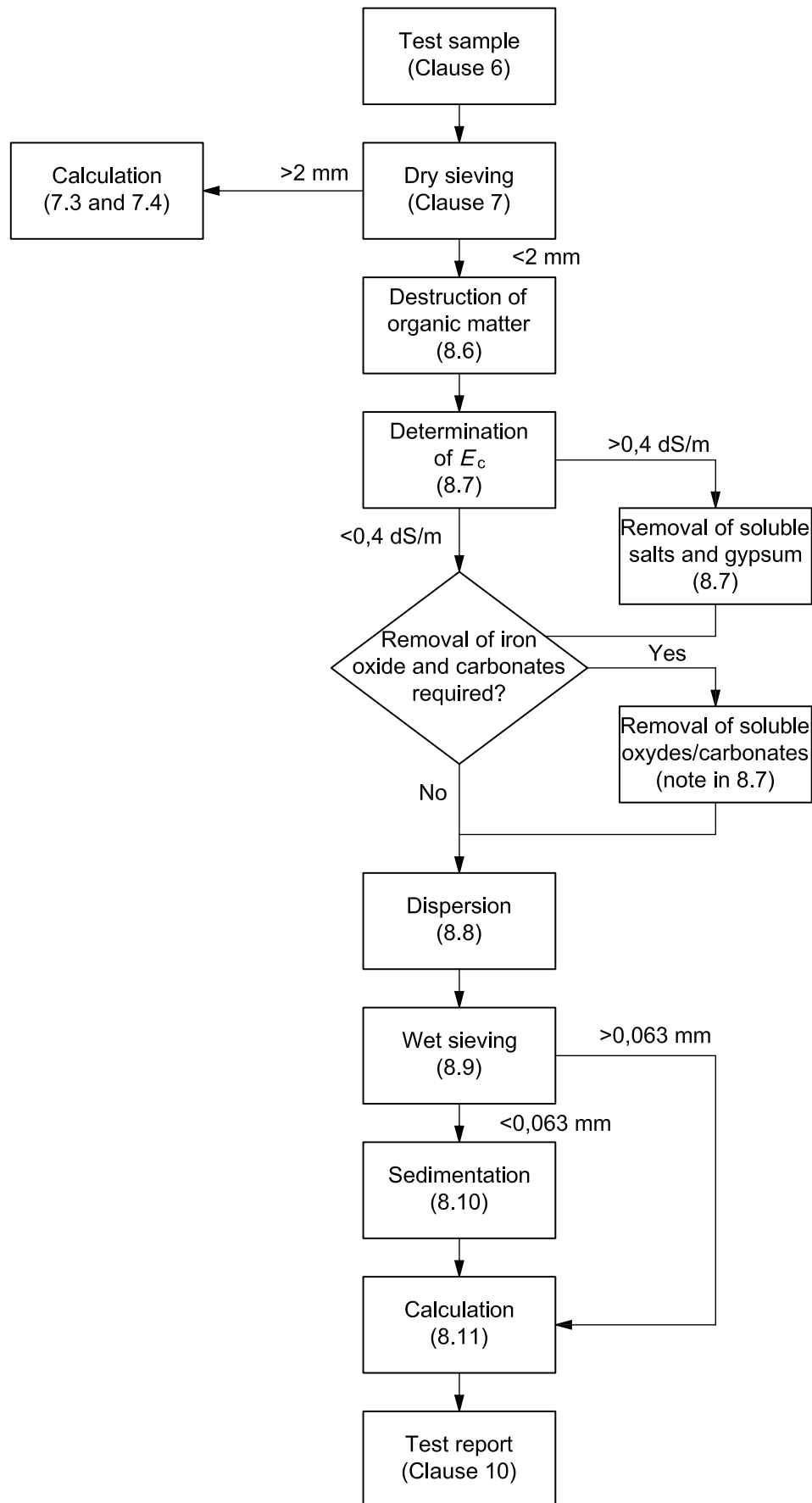
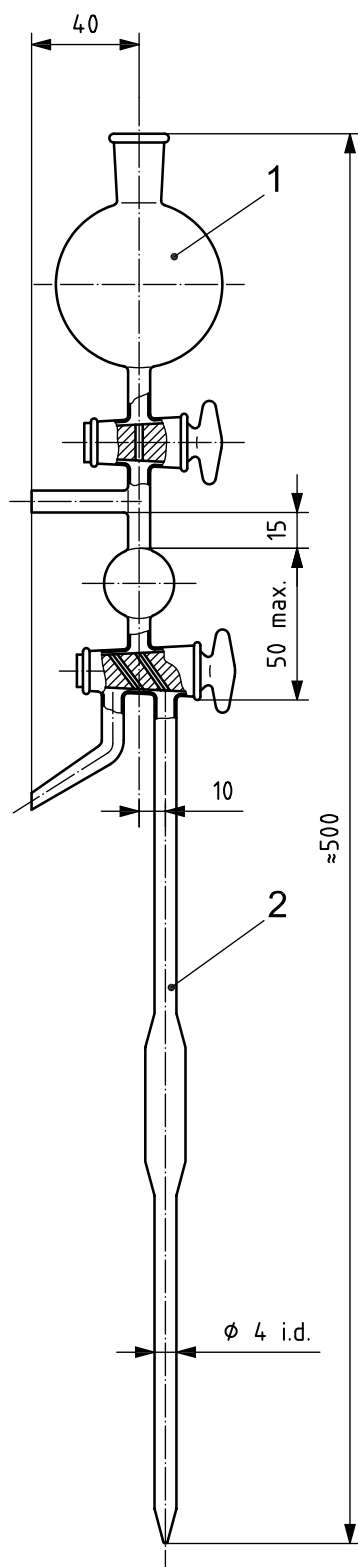

Figure 2 — Flow chart

Dimensions in millimetres



**Key**

- 1 bulb capacity: approximately 125 ml
- 2 pipette and changeover cock capacity: ~ 10 ml

NOTE This design has been found satisfactory, but alternative designs can be used.

**Figure 3 — Sampling pipette for sedimentation test**

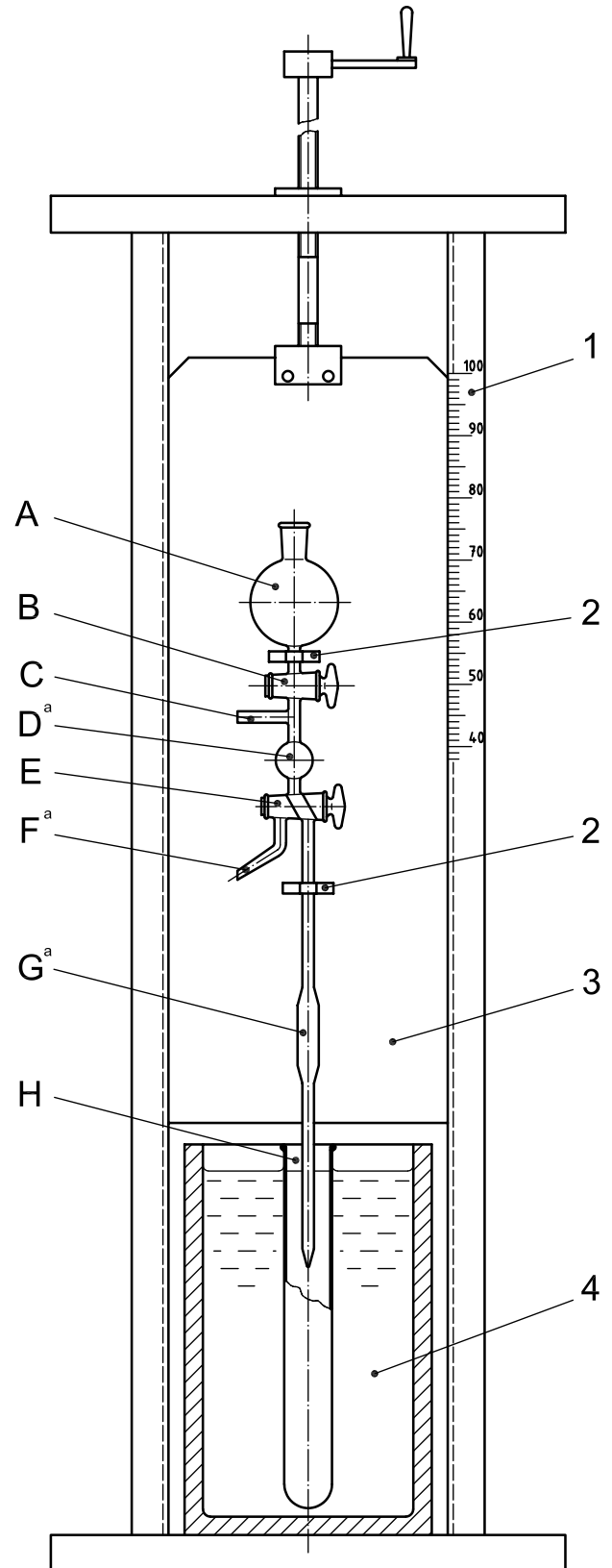

**Key**

- A and B 125 ml bulb funnel with stopcock
- C safety-bulb suction inlet tube
- D safety bulb
- E tap
- F outlet tube
- G sampling pipette
- H sedimentation tube
- 1 scale graduated in millimetres
- 2 clamps
- 3 sliding panel
- 4 constant-temperature bath

NOTE This design has been found satisfactory, but alternative designs can be used.

<sup>a</sup> D, F and G are joined to three-way stopcock E.

**Figure 4 — Arrangement for lowering sampling pipette into soil suspension**

**8.2.2 Constant-temperature room or bath**, which can be maintained at between 20 °C and 30 °C ± 0,5 °C. If a bath is used, it shall accept a sedimentation tube immersed to the 500 ml mark, and shall not vibrate the contents of the tube. Similarly, if a room is used, it, and its furniture, shall be constructed so that activity does not cause the tubes and their contents to vibrate.

**NOTE** This temperature range has been chosen to allow for the difficulties of maintaining one specified temperature in different parts of the world. In addition, the lower temperature gives sedimentation times that fit well into an average working day, whilst the upper temperature still allows for a sensible settling time for the fraction 0,063 mm equivalent spherical diameter (see Clause 4 and Table 3).

**Table 3 — Pipette sampling times and  $d_p$  (for a particle density of 2,65 Mg/m<sup>3</sup>) at a sampling depth of 100 mm ± 1 mm at different temperatures**

Temperature °C	Times, after mixing, of starting sampling operation								
	1st sample <sup>a</sup>		2nd sample		3rd sample		4th sample		
	min	s	min	s	min	s	h	min	s
20	0	56	4	38	51	35	7	44	16
21	0	54	4	32	50	27	7	34	4
22	0	53	4	26	49	19	7	23	53
23	0	52	4	19	48	8	7	13	13
24	0	51	4	13	47	0	7	3	2
25	0	49	4	7	45	52	6	52	50
26	0	48	4	2	44	53	6	44	2
27	0	47	3	57	43	58	6	35	42
28	0	46	3	52	42	59	6	26	53
29	0	45	3	47	42	3	6	18	33
30	0	44	3	41	41	5	6	9	45
$d_p$ (mm)	0,063		0,020		0,006		0,002		

<sup>a</sup> Sampling depth 200 mm ± 1 mm to allow adequate time for the stabilization of the suspension after mixing.

**8.2.3 Two glass sedimentation tubes**, without pouring lips, of internal diameter approximately 50 mm, and overall length 350 mm, graduated at 500 ml volume, and with either rubber bungs to fit or a stirrer.

**8.2.4 Stirrer**, of noncorrodible material, as in Figure 5.

**8.2.5 Five glass weighing vessels**, with masses known to the nearest 0,000 1 g.

**8.2.6 Mechanical shaker**, capable of keeping 30 g of soil in suspension in 150 ml of liquid. A device which rotates the container end-over-end at 30 revolutions/min to 60 revolutions/min is suitable. The vigorous end-to-end type of shaker and the horizontal rotary shaker are both unsuitable, and neither shall be used (see the note in 8.9).

**8.2.7 Test sieves**, complying with ISO 565, ISO 3310-1 and ISO 3310-2, having apertures of 2 mm and 0,063 mm, plus two intermediate sieves. The test report shall state which apertures are used. Round-hole sieves shall not be used.

**NOTE** The choice of the sieve of aperture 0,063 mm given here is for illustration, but accords with the widespread use of this particle size to define the upper boundary of the silt fraction. Local requirements can specify another aperture. The choice of apertures for the intermediate sieves is a matter for local knowledge, but experience suggests that sieves of aperture close to 0,2 mm and 0,1 mm are useful for a very wide range of soils.

Dimensions in millimetres

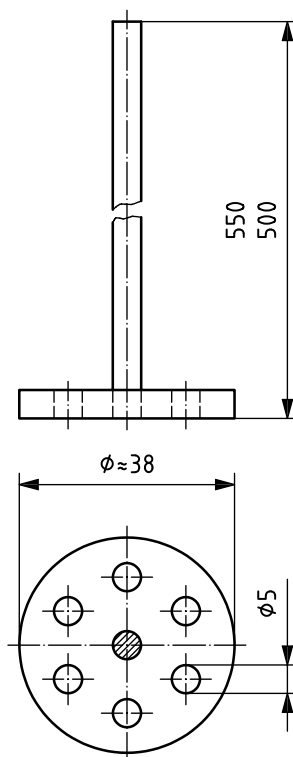

Prepare a stirrer as shown, suitable materials being

- a) brass or aluminium,
- b) poly,(methy/methacrylate), or
- c) a section of a rubber stopper fitted onto a glass rod, etc.

**Figure 5 — Example of stirrer; perforated stopper fitted onto glass rod**

**8.2.8 Suitable sample divider** (Clause 6).

**8.2.9 Balance**, capable of weighing to an accuracy of within  $\pm 0,000$  1 g.

**8.2.10 Drying oven**, capable of maintaining a temperature between 105 °C and 110 °C.

**8.2.11 Stop clock**, readable to 1 s.

**8.2.12 Desiccator**, containing anhydrous silica gel (preferably of the self-indicating type), capable of holding the five weighing vessels. The desiccant shall be inspected daily and dried at between 105 °C and 110 °C when it is no longer effective.

**8.2.13 Tall-form glass beaker**, of capacity 650 ml with a cover glass to fit, or a 300 ml **centrifuge bottle** with a leakproof cap.

**NOTE** This apparatus is used for chemical pretreatment, during which a constant problem is the adhesion of very fine particles to glass. The problem is much reduced if the treatment is carried out in a polycarbonate or polysulfone centrifuge bottle. Both materials will withstand repeated heating to 120 °C and are resistant to hydrogen peroxide and common dispersing agents. Their use can also save significant amounts of operator time.

**8.2.14 Centrifuge**, capable of holding the 300 ml centrifuge bottles (see 8.8).

**8.2.15 Measuring cylinder**, of capacity 100 ml.

**8.2.16 Pipette**, of capacity 25 ml.

**8.2.17 Glass filter funnel**, capable of holding the 0,063 mm sieve.

**8.2.18 Wash bottle** containing water (see 8.3).

**8.2.19 Rod**, of glass or strong plastic, 150 mm to 200 mm long and at least 4 mm in diameter, with a rubber sleeve at one end.

**8.2.20 Electric hotplate**, capable of maintaining a temperature between 105 °C and 110 °C.

**NOTE** A hotplate is essential if polymer centrifuge bottles are used for the chemical pretreatment, but a Bunsen burner, gauze and tripod are sufficient if glass beakers are used.

**8.2.21 Suction device**, similar to that shown in Figure 6 is useful, but not essential.

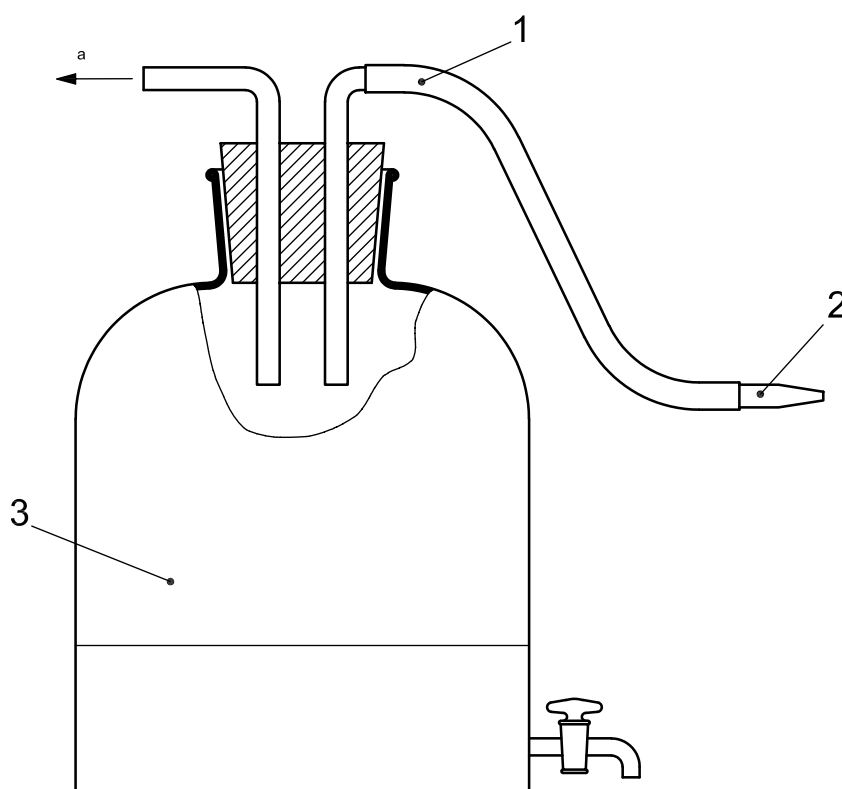

**Key**

- 1 flexible tube
- 2 Pasteur pipette or similar
- 3 reservoir (5 l or 10 l)
- a To vacuum.

**Figure 6 — Sketch of suction device**

**8.2.22 Sieve brush**.

**8.2.23 Electrical conductivity meter**, accurate to 0,1 dS/m.

### 8.3 Reagents

All reagents shall be of recognized analytical grade. Use water conforming to Class 2 of ISO 3696, i.e. having an electrical conductivity no greater than 0,1 dS/m at 25 °C at the time of use.

#### 8.3.1 Hydrogen peroxide solution, 30 % volume fraction.

NOTE A 30 % volume fraction solution is one which will yield 30 ml of gaseous oxygen from 100 ml of solution (under standard conditions of temperature and pressure) upon reduction to water, either by chemical means or by boiling.

#### 8.3.2 Solution of a dispersing agent.

The most widely used dispersing agent is that prepared by dissolving 33 g of sodium hexametaphosphate and 7 g of anhydrous sodium carbonate in water to make 1 L of solution. This is the preferred dispersant. Store away from strong sunlight and preferably in a dark bottle. Record the date of preparation on the bottle. The solution is unstable and shall be replaced after one month.

Buffered sodium hexametaphosphate is commonly referred to in the literature as "Calgon". This is a trade name. The substance sold as such is often not the reagent described in this subclause, is of variable composition, and shall not be used as a dispersing agent in the method given in this International Standard (Reference [8] in the Bibliography).

It is permissible to use other dispersing agents (see the last paragraph of this subclause), the choice of which shall be recorded in the test report (Clause 10). Whichever dispersant proves to be the most suitable for a particular soil, it is essential that the suspension be examined visually to ensure that effective dispersion has occurred and that the dispersed suspension is stable, i.e. that no flocculation has occurred or is occurring. This inspection shall be carried out for each and every sample.

The sodium carbonate buffers the solution, and the suspension of the soil, to about pH 9,8. This dispersing agent has been found successful with a very wide range of soils. However, if there are signs that dispersion is ineffective, consider firstly that flocculating salts might be present (see 8.7). If dispersion is still unsuccessful after removal of salts, then other dispersing agents should be considered. A very effective but less widely used dispersing agent is prepared by replacing the sodium carbonate with 20 % volume fraction ammonia solution, in the ratio of 5 ml ammonia solution to 150 ml of the hexametaphosphate solution. There are many other dispersing agents (Reference [2] in the Bibliography). Whichever is chosen, considerable investigation will be required to establish its effectiveness. It should be remembered that some soils show fewer problems of dispersion if analysed without drying (see Annex A). Some soils derived from recent volcanic deposits will disperse more effectively in an acid medium (Reference [9] in the Bibliography).

#### 8.3.3 Octan-2-ol, or a similar volatile antifoaming agent.

NOTE Octan-2-ol is highly effective and relatively long-lasting. Ethanol or methanol can also be used, but the use of pentan-2-ol (amyl alcohol) is discouraged because it is potentially addictive.

### 8.4 Calibrations

#### 8.4.1 Sampling pipette (Figure 4)

Clean and dry the pipette thoroughly and immerse the tip in water held at the same temperature as that of the constant-temperature environment (8.2.2). By means of a tube attached to C, draw water into the pipette above E. Drain off the water above E through F. Drain the pipette into a weighing bottle of known mass and determine the new mass. From the known masses, calculate the internal volume of the pipette. Repeat this exercise three times and take the average of the three volumes as the internal volume of the pipette to the nearest 0,05 ml ( $V_c$  ml).

#### 8.4.2 Dispersing-agent correction

Follow this procedure each time a new batch of dispersing agent is prepared.

Pipette 25 ml of dispersing-agent solution into one of the glass sedimentation tubes, and fill the tube to the 500 ml mark with water. Mix the contents of the tube thoroughly. Place the tube in the constant-temperature environment, and leave the tube for at least 1 h. Between any of the times at which samples may be taken from the sampling tube (Table 3), take a sample ( $V_c$  ml) of the dispersing-agent solution from the sedimentation tube using the sampling pipette. Drain the pipette into a weighing vessel of known mass, and dry the contents of the vessel between 105 °C and 110 °C. Allow the vessel to cool in the desiccator and determine the mass of the residue in the vessel to 0,000 1 g ( $m_r$ ).

The minimum temperature equilibration period in the water bath is 1 h, but if a large number of tubes is placed in a bath, equilibration will take at least 4 h. In such cases, it is advantageous to arrange the work so that equilibration takes place overnight. Equilibration will be quicker if the supply of water used to fill up the tubes is kept at or near the same temperature as the constant-temperature environment.

#### 8.5 Test sample

The test sample shall be taken from the material passing a 2 mm aperture sieve (see Clause 6 and 7.2) and weighed to the nearest 0,001 g ( $m_s$ ). The mass of test sample depends on the type of soil. Approximately 30 g for a sandy soil and 10 g for a clay soil are appropriate for pipette analysis, with proportionate masses for soils intermediate to these extremes. For the hydrometer method (Annex B), take twice this amount of material. Place the test sample in either the 650 ml glass beaker or the 300 ml centrifuge bottle (8.2.13 and its note).

Highly organic soils contain relatively little mineral matter. It might be necessary to take up to 100 g of such soils in order to obtain sufficient mineral matter for a reliable analysis of the particle size distribution of this component. Such a large amount of organic material should be apportioned between several vessels for ease of operation, with combination of the mineral residues at a later stage.

#### 8.6 Destruction of organic matter

Destroy the organic matter with hydrogen peroxide solution as follows. Add approximately 30 ml of water to the test sample and allow it to become thoroughly wet (see Note 1 below). Add 30 ml of 30 % volume fraction hydrogen peroxide solution and mix the contents of the vessel very gently using the glass or plastic rod. A vigorous reaction can cause foaming of the sample mixture. This can be controlled by adding a few millilitres of octan-2-ol. Allow any vigorous reaction to subside.

**WARNING — Carry out this step with caution. Hydrogen peroxide can decompose violently with some forms of organic matter, manganese compounds and finely-particulate iron sulfides, all of which can occur in soil. Do not examine the reaction by looking into the top of the vessel. Do not accelerate an apparently slow reaction by heating or addition of more hydrogen peroxide.**

If using the 650 ml beaker, cover with the cover glass and leave overnight. Place the vessel on the hotplate or Bunsen burner, as appropriate (8.2.20), and warm gently. Control any foaming with octan-2-ol as before, and stir the contents frequently. Do not allow the contents to dry out, adding more water if necessary. Bring the suspension to a gentle boil and heat until all signs of bubbling due to decomposition of hydrogen peroxide have ceased. If there is still-undecomposed organic matter, remove the vessel from the heat, allow it to cool and repeat the treatment with hydrogen peroxide. Highly organic soils will need several such treatments, the products of the reaction being removed after every 2 or 3 treatments before continuing with more peroxide.

If destruction of organic matter has been carried out in a centrifuge bottle, bring the volume of the contents to between 150 ml and 200 ml by addition of water. If a glass beaker has been used, then transfer the contents to a centrifuge bottle, taking care to remove all traces of material from the sides of the beaker by means of the rubber sleeve on the glass or plastic rod. Again, the final volume should be 150 ml to 200 ml. Centrifuge the bottle so as to obtain a clear supernatant [15 min at a minimum relative centrifugal force (RCF) of 400g is recommended], and decant the latter or remove by means of the suction device. Repeat the treatment until the supernatant is colourless or nearly so.



NOTE 1 Dry organic materials are often strongly hydrophobic, in which case the addition of a few drops of octan-2-ol can be beneficial.

If a centrifuge is not available, the mineral residues may be flocculated by adding 25 ml of 1 mol/l calcium chloride solution. Stir thoroughly, bring to about 250 ml with water, allow to stand until the supernatant is clear, then siphon or decant this from the residue. Add another 250 ml of water and repeat the washing procedure until the dark residues of the decomposed organic matter have gone. Check that the electrical conductivity of the washings is below 0,4 dS/m before attempting to disperse the residue (see 8.8).

Another alternative is to filter the residue from the oxidation step on a hardened, high wet-strength filter paper (2,7 µm pore size is suitable), followed by thorough washing with water by means of the wash-bottle. It is essential to observe the filtrate closely to see that no soil is lost. If particles pass through the filter paper, return the filtrate to the container, add calcium chloride solution to the suspension as above, stir and refilter.

If flocculation with calcium chloride, or filtration, are ineffective in preventing the loss of fine soil particles, then a few drops of a 60 g/l aluminium sulfate solution can be stirred into the soil suspension. The absolute minimum of aluminium sulfate shall be used, as excess could cause problems in the subsequent dispersion of the soil.

NOTE 2 Lignified (woody) residues of plants are extremely difficult to decompose, and their complete destruction is often impossible. Such fragments are usually regarded as decomposed when they have lost all traces of dark colour.

Transfer the washed residue quantitatively to a centrifuge bottle. In all cases, it is not essential for the supernatant to be absolutely colourless, so long as it is obvious that the bulk of the dark decomposition products of the organic matter have been removed, but the solution shall be clear. The use of calcium chloride solution or aluminium sulfate solution, in conjunction with filtration, decantation, suction or siphoning, shall be recorded in the test report (Clause 10).

## 8.7 Removal of soluble salts and gypsum

After removal of the residues following the destruction of organic matter, add sufficient water to the soil in the centrifuge bottle so that the soil:water ratio is between 1:4 and 1:6 by volume. Shake the contents of the bottle vigorously so that all the sediment is in suspension; then shake for 1 h on the end-over-end shaking machine. Centrifuge to obtain a clear supernatant and measure its electrical conductivity ( $E_c$ ). If the latter is  $< 0,4$  dS/m, soluble salts and gypsum are not present in significant amounts. If the value of  $E_c$  is  $> 0,4$  dS/m, then remove the supernatant in which  $E_c$  was measured. Add 250 ml of water to the soil residue, cap the bottle and shake on the end-over-end shaking machine for 1 h. Centrifuge to obtain a clear supernatant and measure  $E_c$  again. If it is  $< 0,4$  dS/m, soluble salts and gypsum have been removed to an extent sufficient not to interfere in the dispersion (8.8). If the  $E_c$  is  $> 0,4$  dS/m, repeat the washing procedure until the  $E_c$  of the supernatant is  $< 0,4$  dS/m. Record the removal of gypsum in the test report (Clause 10).

Whilst the removal of soluble salts and gypsum is obligatory, that of iron (and associated aluminium) oxides and of carbonates is not (see note below). The removal of these compounds is a matter for local decision, but if done, the preferred procedures are as follows. Iron oxides are removed by shaking the soil overnight with 40 g/l sodium dithionite in approximately 0,3 mol/l sodium acetate solution buffered to pH 3,8 with acetic acid, in the ratio of 1 part soil to 40 parts of solution, both by volume.

Very iron-rich soils usually need several treatments. Magnetite is not affected by this procedure (Reference [4] in the Bibliography). In certain soils, especially those developed from recent volcanic deposits, this reagent can remove large quantities of aluminium as well as iron. Calcium and magnesium carbonates are removed by treating the soil with the minimum possible excess of aqueous hydrochloric acid.

The following procedure has been found to be applicable to a wide range of soils, and is best applied to the soil after the removal of organic matter (8.6). Where the mass fraction of carbonate is greater than about 2 %, add, to the washed, centrifuged soil (see above), 4 ml of 1 mol/l hydrochloric acid for each percent of carbonate, plus an excess of 25 ml of acid. Make up to about 250 ml with water and place the suspension on the water bath at about 80 °C for 15 min, stirring the suspension from time to time. Remove from the water bath and leave the suspension to stand overnight. If the soil flocculates sufficiently to leave a perfectly clear supernatant, then this can be siphoned off or decanted, otherwise centrifugation (see 8.6) and decantation will be necessary. Repeat the washing and decantation with water until the  $E_c$  of the supernatant is less than

0,4 dS/m. If the mass fraction of carbonate is less than about 2 %, then only an initial 25 ml of 1 mol/l hydrochloric acid solution is required. However, there is then the risk that there will be insufficient calcium in solution to give good flocculation. It is recommended, therefore, that 20 ml of 1 mol/l calcium chloride solution be added at the same time as the acid. The rest of the procedure is identical for both situations. If magnesium carbonates are present in substantial amounts, then the treatment can be lengthy. Hot hydrochloric acid shall not be used in soils containing significant amounts of chlorite, as this can dissolve.

Removal of iron/aluminium oxides and/or carbonates shall be recorded in the test report (Clause 10).

NOTE Because of the slowness of the procedure and the difficulty of quantitative recovery of the residue, removal of carbonates is not normally a routine procedure in the determination of particle size distribution.

## 8.8 Dispersion

Add sufficient water to the centrifuge bottle so that the total volume is between 150 ml and 200 ml, shake the contents until all the soil is in suspension, and add 25 ml of dispersing agent from a pipette. Shake the bottle for 18 h on the end-over-end shaker. Ensure that, if soils are shaken over the weekend, the total shaking time is 18 h.

NOTE For operational reasons, overnight shaking is a sensible option.

If an end-over-end shaker is not available, then a vibrating blade stirrer can be used, but the blender type of stirrer should not be used because it can comminute primary particles.

## 8.9 Wet sieving at 0,063 mm

Place a 0,063 mm aperture sieve in the large glass funnel, and place the funnel in the stand so that the neck of the funnel is inside one of the 500 ml sedimentation tubes. Transfer the dispersed suspension from the centrifuge bottle quantitatively onto the sieve, and wash the soil using a jet of water from the wash-bottle until the water runs clear. If necessary, agitate the suspension on the sieve to alleviate sieve blockage, using the glass or plastic rod and rubber sleeve. Take great care to avoid damage to the sieve mesh when this is done. The total volume of the washings should not exceed 500 ml.

NOTE Certain highly weathered tropical soils can be difficult to sieve, and it can help to wet the sieve by gently rubbing a few drops of dispersing agent over and under the mesh prior to this step.

Remove the sieve from the funnel and wash the residue on the sieve into an evaporating dish by means of a gentle spray from the wash-bottle. Place this dish in an oven between 105 °C and 110 °C until the residue is dry. Wash any particles adhering to the inside of the funnel into the sedimentation tube. Allow the dried residue to cool, and re-sieve on the sieves < 2 mm down to 0,063 mm, returning any material passing the latter to the sedimentation cylinder. Weigh the fractions retained on each sieve, and record their masses. Make up the suspension in the sedimentation tube to 500 ml with water.

## 8.10 Sedimentation

Place the sedimentation tube in the constant-temperature environment. If a bath is used, the tube shall be immersed to the 500 ml mark. Allow the tube and contents to equilibrate with the temperature of the system (see the last paragraph of 8.4.2). Agitate the contents of the sedimentation tube vigorously, either by means of the stirrer, which should be used with a powerful plunging action, or by inserting a bung in the tube, followed by end-over-end shaking. In both cases, no material shall be left adhering to the base of the tube. The contents of the tube shall be agitated at least 30 times/min for a minimum of 2 min. Replace the tube upright in the constant-temperature environment.

The instant the tube and contents are placed upright or stirring with the plunger stops, start the timer. If rubber bungs have been used, then remove them from the cylinder, taking care not to agitate the cylinder whilst doing so. About 15 s before a sample is to be taken (see Table 3), lower the pipette, with tap E (see Figure 4) closed, vertically into the soil suspension and centrally in the sedimentation tube, until the tip is the appropriate depth ( $\pm 1$  mm) below the suspension surface (Table 3). Take care to disturb the suspension as little as possible, and complete the operation within about 10 s. Open tap E and withdraw a sample of the

suspension such that the pipette and the bore of tap E are full. This sampling operation shall take about 10 s. Withdraw the pipette from the suspension so that the tip of the pipette is clear of the top of the sedimentation tube.

During the sampling, some of the suspension can be drawn above tap E into bulb D (see Figure 4). Run this surplus into a small beaker down outlet tube F by opening tap E so that E and D are connected. Wash with water from reservoir A into D and out through F until no suspension remains in this part of the system.

Place a weighing vessel of known mass, to the nearest 0,000 1 g, under the tip of the pipette and open tap E so that the contents of the pipette are delivered to the vessel. Wash any suspension left on the inner walls of the pipette into the vessel by allowing water from reservoir A to run through the system. Place the weighing vessel and its contents in the oven between 105 °C and 110 °C, and evaporate to dryness. Cool the vessel in the desiccator, weigh the vessel and its contents to the nearest 0,000 1 g, and determine the mass of the residue to the nearest 0,000 1 g ( $ms_1$ ). Clean the outside of the pipette of any adhering sediment, and take further samples, as required, in accordance with the times given in Table 3, using the same pipetting procedure as given above. Call the additional sample masses  $ms_2$ ,  $ms_3$ , etc. The fractions 0,063 mm to 0,002 mm and < 0,002 mm shall be determined as a minimum. The construction of a particle-size-distribution curve requires that at least two other fractions intermediate between these two points be determined.

**NOTE** The choice of the two fractions is a matter for local decision. Experience suggests that it is more important to determine the amount of material below 0,032 mm equivalent spherical diameter than material above that size, if a reliable particle-size-distribution curve is to be drawn.

### 8.11 Calculation of results for fractions < 2 mm

The method of calculation assumes that the sample mass is the sum of the constituent fractions, and not the mass of sample taken as specified in 8.5.

**NOTE** This approach has its drawbacks in that it assumes that there are no significant errors at various stages of the sampling, drying and weighing of each fraction. However, in order that this International Standard be applicable to the widest range of soils, it is believed that this assumption is preferable to the risk of errors arising from the inadequate dispersion of oven-dried soil. The method given in this subclause is thus the preferred method.

Calculate the mass of solid in suspension in 500 ml ( $mf_1$ ,  $mf_2$ ,  $mf_3$ , etc.) in grams, for each pipette sampling time from the equation:

$$mf_x = ms_x (500/V_c)$$

where

$mf_x$  is the mass of solid in suspension in 500 ml, in grams;

$ms_x$  is the mass of material from the  $x$ th pipette sampling, in grams;

$V_c$  is the calibrated volume of the pipette, in millilitres.

Similarly, the mass of solid material in 500 ml of dispersant solution,  $m_d$ , in grams, is given by:

$$m_d = m_r (500/V_c)$$

where

$m_r$  is the mass of residue, in grams;

$V_c$  is the calibrated volume of the pipette, in millilitres.

By way of example, denote the masses of the pipetted fractions (calculated as in 500 ml) as follows:

$$\text{fraction} < 0,063 \text{ mm} = mf_1;$$

$$\text{fraction} < 0,020 \text{ mm} = mf_2;$$

$$\text{fraction} < 0,002 \text{ mm} = mf_3.$$

The samples taken at the shorter time intervals will contain the material of smaller particle size and each sample will contain the same mass of dispersant, i.e.  $m_r$ . Thus the mass of the fractions, in grams, can be calculated as:

$$\text{mass of fraction} < 0,063 \text{ mm to} < 0,020 \text{ mm} = mf_1 \ 2 \ mf_2 = m(0,063 \text{ mm to } 0,020 \text{ mm});$$

$$\text{mass of fraction} < 0,020 \text{ mm to} > 0,002 \text{ mm} = mf_2 \ 2 \ mf_3 = m(0,020 \text{ mm to } 0,002 \text{ mm});$$

$$\text{mass of fraction} < 0,002 \text{ mm} = mf_3 \ 2 \ m_d = m(< 0,002 \text{ mm}).$$

The principle is extended to other fractions sampled. The mass of sample  $< 2$  mm is thus the sum of the masses of the fractions obtained by wet sieving at 0,063 mm and the masses of the fractions obtained by calculation. Denote this total sample mass as  $m_t$ , in grams.

Calculate the proportion in each fraction  $< 2$  mm as follows:

$$\text{Proportion} = \text{mass of fraction} / m_t$$

If required, the proportions of material  $< 2$  mm in diameter can be recalculated as proportions of the total soil mass inclusive of material  $> 2$  mm in diameter, as follows:

$$\text{Proportion in total soil mass} = P_t(< 2 \text{ mm}) \times P_s(< 2 \text{ mm})$$

where

$$P_t(< 2 \text{ mm}) \text{ is the proportion of the fraction } < 2 \text{ mm};$$

$$P_s(< 2 \text{ mm}) \text{ is the proportion of material } < 2 \text{ mm in the total soil (Clause 7).}$$

Present the results as a table showing the proportion in each size fraction to two significant figures. State clearly the basis on which the results are presented, i.e. as a proportion of the material  $< 2$  mm, or as a proportion of the total soil. In addition, the results shall also be presented as a cumulative particle-size-distribution curve (Figure 1).

## 9 Precision

The information in Table 4 is based on replicate analysis ( $n = 12$ ) of soil types including cambic and humic arenosols, mollic and calcareic gleysols and fluvisols, a rendzic leptosol, a gypsic regosol, a eutric vertisol, a dystric cambisol and haplic and ferric podzols. The standard deviations are given as the maximum that could be expected for the stated size fraction for such a range of soil types. Individual laboratories are urged strongly to accumulate such data as part of a continuous quality control exercise.

**Table 4 — Precision data**

<b>Size fraction mm</b>	<b>Standard deviation as % of content in fraction</b>
2,000 to 0,600	< 1
0,600 to 0,212	< 2,5
0,212 to 0,063	< 3
0,063 to 0,002	< 2
< 0,002	< 2

## 10 Test report

The test report shall include the following information:

- a) a reference to this International Standard;
- b) the date of the laboratory analysis;
- c) the methods of test used, specifying the parts of the standard used where alternatives exist, in accordance with the instructions given within this International Standard;
- d) the results of the sieve and pipette analyses, or the hydrometer analyses, as appropriate;
- e) sufficient information to identify the sample unequivocally within the laboratory records;
- f) the name of the operator;
- g) the name and address of the laboratory.

## Annex A (normative)

### Determination of particle size distribution of mineral soil material that is not dried prior to analysis

#### A.1 Introduction

This annex specifies the procedure for soils which should not be dried because of the resulting change in properties, especially their dispersion characteristics. Some loss of precision can be expected with this method, especially with cohesive soils, due to the greater difficulty in obtaining a representative sample, especially of the < 2 mm soil. However, this loss of precision is likely to be less than the errors arising from analysis of the dried soil. The decision as to which soils should or should not be analysed from the wet state is a matter for local judgement. The soils most likely to need this approach are those developed from recent volcanic materials, certain highly oxidized tropical soils, and highly cohesive soils. The method involves the wet sieving of material down to 2 mm, below which size the material is discarded. A separate sample is taken for the determination of particles < 2 mm in diameter. It is important that the two test samples be taken at about the same time from the field sample, so that they are submitted to the test procedure at similar gravimetric moisture contents. Samples of mass equal to the two test samples are taken for the determination of the dry mass of the material, and these masses are used in the calculation of the proportions of the size fractions present in the soil.

#### A.2 Procedure for material retained on a 2 mm aperture sieve

##### A.2.1 Apparatus

- A.2.1.1 **Set of test sieves**, in accordance with 7.2.1.
- A.2.1.2 **Balance**, capable of weighing to within an accuracy of  $\pm 0,5$  g.
- A.2.1.3 **Drying oven**, capable of maintaining a temperature between 105 °C and 110 °C.
- A.2.1.4 **Several corrosion-resistant trays**.  
Those made from aluminium alloy sheet about 2 mm thick, with sides about 25 mm deep and a base of length about 300 mm, will be suitable.
- A.2.1.5 **Plastic bucket**, or other corrosion-resistant container of about 10 L capacity.
- A.2.1.6 **Sieve brushes** and a **stiff brush** such as a wire brush.
- A.2.1.7 **Sodium hexametaphosphate solution** or other suitable dispersing agent (8.3.2).
- A.2.1.8 **Means of supporting the test sieves** and a **device for washing** the material on the sieves.

A length of 6 mm bore tubing attached to a tap, or a fine-jet watering-can will suffice for washing.

### A.3 The test sample

Take a mass of sample (Clause 6) for sieving in proportion to the largest particles present (see Table 1). Weigh the sample to the nearest 0,5 g and record the mass ( $m_1$ ). Take an equal mass of sample by an exactly equivalent procedure and record the mass. Place this sample in a non-corroding tray and dry it in an oven at between 105 °C and 110 °C. Record the dry mass to the nearest 0,5 g ( $m_2$ ).

### A.4 Dispersion

Place the undried test sample in the plastic bucket, add about 5 L of water and 350 ml of dispersing agent. The sample shall be covered by the solution. Mix the contents of the container gently and allow to stand overnight.

**NOTE** It is impracticable to attempt to destroy organic matter in samples of this size. Note also that the remarks concerning dispersion, other than those related to problems of drying, given in the last paragraph of 8.3.2 might still apply.

### A.5 Sieving at 2 mm

Mix the sample in the bucket gently again, and then pour the suspension slowly onto a nest of sieves (see Clause 7). Table 2 gives the mass of sample to be taken in relation to sieve size. Several sievings of portions of the suspension might be needed. Make sure there is no material remaining in the bucket, and then gently brush the material on the largest-aperture sieve with the stiff brush to remove any material adhering to the primary particles. Ensure that no fragments of the latter are dislodged during this process. Wash the material on the sieves thoroughly and wash onto the sieve any material adhering to the brush; tap water will suffice for this purpose. Allow the material passing the 2 mm sieve to run to waste. Sieve the material on the nest of sieves, brush each fraction into a weighed dish and dry at between 105 °C and 110 °C. Record the mass retained on each sieve to the nearest 0,5 g. The material retained on the 2 mm sieve should be washed thoroughly, any further material passing the sieve being allowed to run to waste.

The extent to which coarse particles absorb water is impossible to estimate by eye. Unless local experience suggests strongly to the contrary, all fractions should be dried before weighing. It is realized that there is an apparent paradox in drying fractions separated by a wet process, and reporting dry-mass proportions. However, wet separation is practiced to avoid difficulties in dispersion of dried soil and to avoid changes in particle size distribution due to shrinkage and adhesion of particles upon drying. The method given is the preferred method. The masses of the fractions can be reported as proportions of each in the wet soil, if this is desired for some reason. The moisture content of each fraction and of the original material shall then be given in the test report. The practical difficulties of this approach in routine analysis are very real, and intercomparison of results between this and the preferred method will be difficult.

Transfer the material retained on the 2 mm aperture sieve to a non-corroding tray, and dry the contents in the oven at a temperature between 105 °C and 110 °C. Sieve this dried material on a 2 mm aperture sieve, and record the mass of the material retained, to the nearest 0,5 g. Reject any material passing this sieve.

### A.6 Calculation and expression of results

#### A.6.1 Calculation

Calculate the mass of material retained on each sieve as a proportion of the oven-dried sample mass  $m_2$ . For example:

$$\text{Proportion retained on the 16 mm sieve} = m(16 \text{ mm})/m_2$$

### A.6.2 Expression of results

Present the results as a table showing the proportion by mass, to two significant figures, retained on each sieve. In addition, the results shall be shown as a cumulative distribution curve (Figure 1).

### A.7 Wet sieving of material < 2 mm diameter

Sieve the field-moist sample on a 2 mm aperture sieve so as to obtain about 300 g of < 2 mm diameter material. It is usually necessary to rub the sample gently over the sieve mesh to do this. Take care not to damage the sieve mesh or disaggregate primary particles. Take two subsamples, of about 30 g each, by quartering the sieved material. The masses of the two samples shall agree to within 0,5 g ( $m_3$  and  $m_4$ ).

**NOTE** It is convenient to keep a separate 2 mm sieve for this purpose. It can also be convenient to keep a complete set of sieves for wet sieving if this is to be carried out often. Place one subsample in a non-corroding tray and dry it as in Clause A.3. Record the mass of the dried sample ( $m_5$ ). The other subsample is taken for sieving and sedimentation in accordance with the procedures in 8.9 and 8.10, respectively.

### A.8 Calculation and expression of results

The proportions of material in the fractions < 2 mm equivalent spherical diameter are calculated and expressed as in 8.11 as proportions of the oven-dried mass ( $m_5$ ).

### A.9 Test report

This shall be made in accordance with the criteria given in Clause 10. In addition, the report shall state clearly that the analysis was made on undried material, and the relevant clauses of this International Standard shall be stated.



## Annex B (normative)

### Determination of particle size distribution of mineral soils by a hydrometer method following destruction of organic matter

#### B.1 Introduction

This annex specifies the method to be followed for the quantitative determination, by means of a hydrometer, of the particle size distribution of mineral soil material that has been wet-sieved through a 0,063 mm aperture sieve. The analysis requires that the particle density be known or be able to be assumed (see Clause 4), and that the mass of soil taken for analysis, and the organic carbon content of the sample, be known (Reference [3] in the Bibliography). Studies have shown that the hydrometer method is less precise than the pipette method, and that the single greatest error in the former lies in the reading of the hydrometer scale. The hydrometer method shall not be used for samples in which organic matter has not been destroyed, as floating organic matter exacerbates the latter problem.

#### B.2 Apparatus

Items for which details are not otherwise given are as stated in 8.2.

##### B.2.1 Hydrometer, of the type illustrated in Figure B.1.

The bulb and stem shall be made from glass free from visible defects, resistant to chemicals and well annealed. Any loading materials fitted to the outside base of the hydrometer shall be affixed with a heat- (up to 80 °C), water- and chemical-resistant cement. The soundness of the fixative shall be verified at least weekly when the hydrometer is in use and repaired if not in good condition. The scale and markings shall be in permanent ink on a high-quality paper with a smooth surface (Esparto paper is a suitable grade). The stem and bulb shall be circular in cross-section and symmetrical about their common long axis. There shall be no abrupt changes of form that will hinder drying and cleaning, or allow the entrapment of air bubbles. The hydrometer shall float, over its whole range, with the stem within 1,5° of the vertical. The graduation lines shall be straight, of uniform thickness, and show no irregularities in spacing. The scale shall be straight, without twist, and with graduation lines at right angles to the long axis of the hydrometer. The graduation lines shall be every 0,000 5 g/ml, in the format shown in Figure B.1. The basis of the scale shall be density (mass per unit volume) in grams per millilitre. The hydrometer shall be calibrated such that, when placed in water at 20 °C, it shows the true density of water at that temperature (see the last paragraph of this subclause). The hydrometer shall be adjusted in relation to a liquid having a surface tension of about 55 mN/m. The maximum permissible scale error shall be plus or minus one scale division, i.e.  $\pm 0,000 5$  g/l. The following shall be marked legibly and permanently on the bulb of the hydrometer in a manner that does not obscure any part of the scale:

- a) the basis of the scale, e.g. g/ml at 20 °C (this is the usual basis for commercially available hydrometers);
- b) the maker's name or mark;
- c) a certifying number;
- d) the number of this International Standard.

Any alteration or repair to the hydrometer can change its mass, and hence require its recalibration. The masses of hydrometers shall be verified at least once a month when they are in frequent use. The mass of a hydrometer shall always be checked when the instrument is brought back into use after an interval. The identifying numbers and masses of hydrometers shall be recorded in a book kept for that purpose. Readings taken from hydrometers used in this International Standard shall be recorded in the following manner.

Subtract 1,000 from the scale reading and multiply the remaining number by 1 000 (see the last paragraph of this subclause). Scale readings < 1,000 will give negative values, whilst scale readings > 1,000 will give positive values.

Dimensions in millimetres

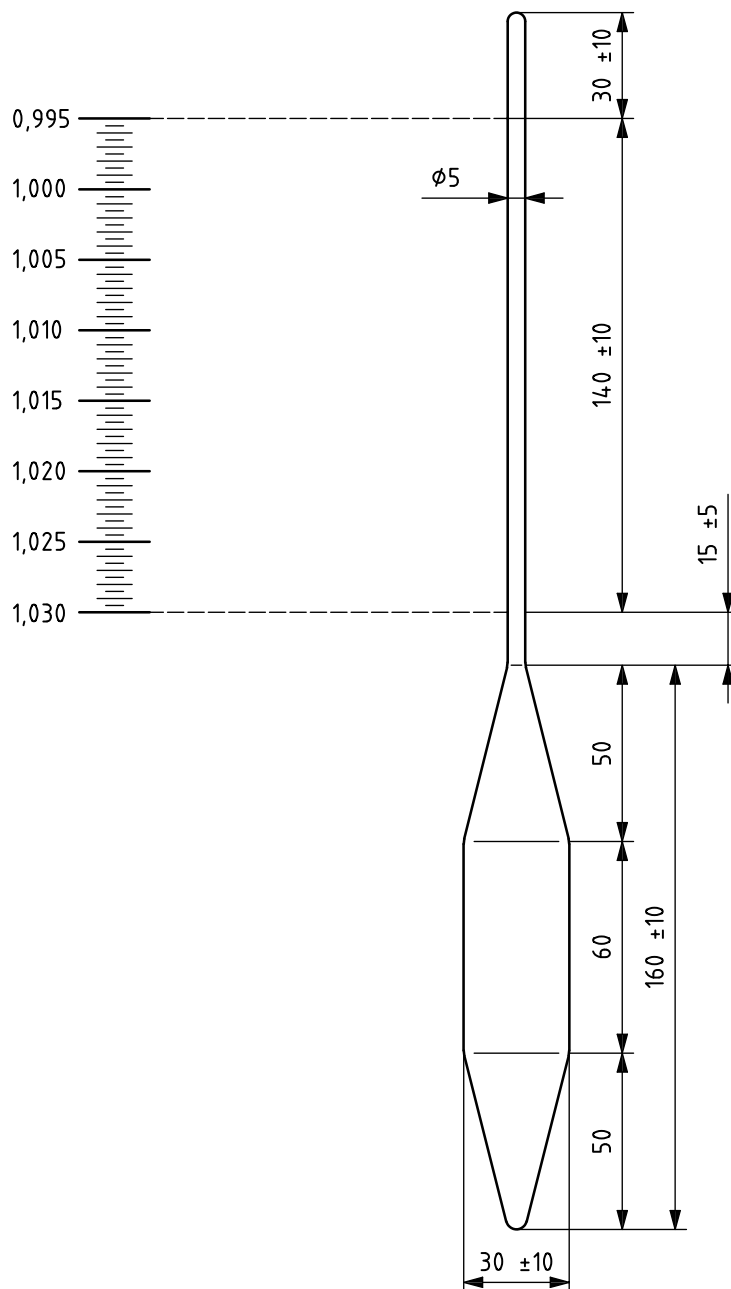

NOTE Calibrations in g/ml at 20 °C.

**Figure B.1 — Hydrometer for determination of fine particle size**

For example:

Observed reading	Recorded value
0,999 5	-0,5
1,000 0	0,0
1,001 5	+1,5

Older hydrometers are commonly calibrated to read a density of water of 1,000 0 g/ml at 20 °C, rather than the true density of 0,998 2 g/ml (References [3, 5] in the Bibliography). It is strongly recommended that older hydrometers of this type not be used in this International Standard. If there are no others available, then a value of 1,8 shall be added to the observed hydrometer reading  $d'$  (see Clauses B.4 and B.5 and Table B.1).

**B.2.2 Two 1 L measuring cylinders**, marked at 1 L volume, about 60 mm in diameter, 360 mm high and fitted with ground-glass stoppers.

It is important that all the cylinders have similar dimensions, as this affects the calibration of the hydrometer (B.2.1). If glass stoppers are unavailable, well-fitting rubber stoppers may be used. The cylinders shall not have pouring lips.

**B.2.3 Thermometer**, to cover the temperature range 0 °C to 50 °C, readable to  $\pm 0,5$  °C.

**B.2.4 Mechanical shaker**, capable of keeping 75 g of soil and 150 ml of water in continuous suspension (see 8.2.6).

**B.2.5 Stop clock**, readable to 1 s.

**B.2.6 Millimetre scale**, such as a steel rule.

**B.2.7 Wash bottle**, and a **100 ml measuring cylinder**.

**B.2.8 Constant-temperature environment** capable of being maintained between 20 °C and 30 °C to an accuracy of  $\pm 0,5$  °C (see 8.2.2 and the last paragraph of 8.2.1). If a water bath is used, it shall be capable of accepting the sedimentation tubes immersed to the 1 L mark.

## B.3 Reagents

All reagents and water shall be of the same quality as specified in the first paragraph of 8.3.

**B.3.1 Solution of a dispersing agent** (see 8.3.2).

**B.3.2 Antifoaming agent** (see 8.3.3).

## B.4 Calibrations and corrections

### B.4.1 General

The hydrometer is used to determine the (usually small) difference in density between a suspension of particles and the liquid (as a separate sample) in which the particles are suspended, this difference being proportional to the amount of particles in suspension. Because the density difference is small, the hydrometer phrasing read as accurately as possible, and any factors which affect this reading shall be allowed for in calculating the particle size parameters. These factors are considered in B.4.2, B.4.3 and B.4.4, and Reference [3] in the Bibliography.

#### B.4.2 Volume calibration of the hydrometer

The volume of the hydrometer shall be known, as it affects the amount by which the level of the liquid in the cylinder rises when the hydrometer is inserted. Stand a 1 L measuring cylinder on a smooth, level surface, pour approximately 800 ml of water into the cylinder, and record the reading of the water level. Immerse the hydrometer in the water and record the level again. Record the difference between the two levels as the volume of the hydrometer,  $V_h$ , in millilitres.

#### B.4.3 Scale calibration of the hydrometer

The magnitude of this correction is affected by both the volume of the hydrometer (B.4.2), and the sectional area of the sedimentation cylinder, hence the need for cylinders of similar dimensions (B.2.2). Refer to Figure B.2. Use the steel rule to measure the distance between two graduations on the 1 L measuring cylinder (e.g. 100 ml to 900 ml). Call this distance  $L$  (in millimetres), and the indicated volume between the graduations  $V_L$  (in millilitres). Measure and record the distance from the lowest calibration mark on the stem of the hydrometer to each of the other major calibration marks,  $d_1, d_2, d_3$ , etc. Measure and record the distance  $d_n$  from the neck of the bulb to the nearest calibration mark. The distances  $H_1, H_2, H_3$ , etc., corresponding to readings  $d_1, d_2, d_3, d_n$ , etc., are equal to the sums  $d_n+d_1, d_n+d_2, d_n+d_3$ , etc. Measure and record the distance,  $h$  (in millimetres), from the neck to the bottom of the bulb, as the height of the bulb. Calculate the effective depths,  $z_1, z_2, z_3$ , etc., corresponding to each of the calibration marks,  $d_1, d_2, d_3, d_n$ , etc., from the formula:

$$z_1 = H_1 + 1/2(h - V_h L / V_L)$$

where

$H_1$  is the length from the neck of the bulb to graduation  $d_1$ , in millimetres;

$h$  is the height of the bulb, in millimetres;

$V_h$  is the volume of the hydrometer bulb, in millilitres;

$L$  is the distance between the graduation marks on the measuring cylinder, in millimetres;

$V_L$  is the indicated volume of the measuring cylinder between the graduations used in the determination of  $L$ , in millilitres.

Plot the relationship between  $z$  and  $d$  as a smooth curve. Record the identification number of the hydrometer and the date of the calibration on the calibration readings and the graph.

NOTE This relationship gives the effective depth of the suspension, the relative density of which is given by the hydrometer reading.

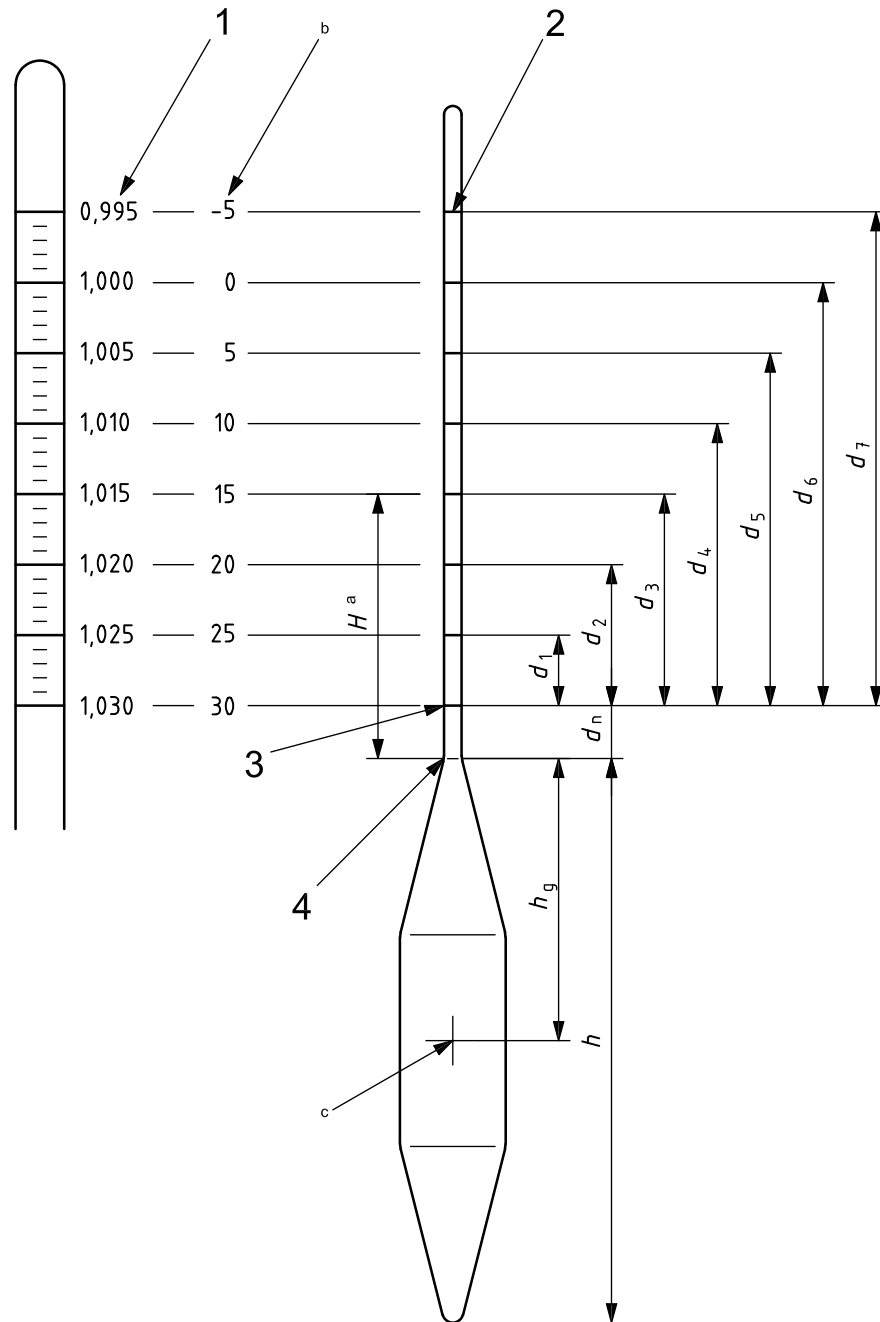

**Key**

- |  |                           |
|--|---------------------------|
| 1 hydrometer relative density markings | 3 lowest calibration mark |
| 2 main calibration marks               | 4 neck of bulb            |

a Example:  $H$  is shown for  $V_h$  of 15.

b Equivalent  $V_h$ .

c Centre of volume of bulb.

NOTE For a symmetrical bulb,  $h_g = h/2$

**Figure B.2 — Essential measurements for calibration of hydrometer**

#### B.4.4 Meniscus correction

A hydrometer is calibrated to read correctly at the surface of the liquid in which it is immersed. This is not possible with opaque soil suspensions, which allow the hydrometer to be read only at the upper surface of the meniscus. The meniscus correction allows for this, but does assume that the meniscus is always fully developed. It is thus essential that the hydrometer be scrupulously clean and that the surface tension of the suspension always be the same (see B.2.1 and the third paragraph of this subclause).

Surfactants can alter the surface tension of liquids appreciably, and this will affect the meniscus correction. The effect of the surfactant chosen shall be checked in this respect and, if significant, a separate calibration of the hydrometer should be made.

If a surfactant is used on the soil suspension, then it should also be used on the cylinder of dispersant solution, so as to maintain comparability of surface tension effects. If the surfactant is changed, then the calibrations of the hydrometer should be repeated.

Insert the hydrometer into a 1 L measuring cylinder, which shall be standing on a smooth level surface, containing about 800 ml of water. By placing the eye slightly below the plane of the surface of the liquid and then raising it slowly until the surface, seen as an ellipse, becomes a straight line, determine the point where the plane intersects the hydrometer scale. By placing the eye slightly above the plane of the surface of the liquid and then lowering it slowly, determine the point where the upper limit of the meniscus intercepts the hydrometer scale. Record the difference between these two readings as the meniscus correction,  $z_m$  (see the note below).

NOTE The meniscus correction ( $z_m$ ), which phrasing added to  $d'$  (the observed hydrometer reading) to obtain  $d$ , the true reading, is a constant for each hydrometer.

#### B.5 Sedimentation

Collect the material passing the 0,063 mm sieve in a 1 L measuring cylinder (see 8.9). Ensure that the level of the suspension is up to the 1 L mark. Insert the ground-glass stopper or rubber stopper into the cylinder containing the soil material, shake it thoroughly so that all the sediment is in suspension, and place the cylinder in the constant-temperature environment (B.2.8). Experience has shown that it is extremely tiring to thoroughly mix the contents of 1 L cylinders using a plunger device, especially when several cylinders need to be mixed in succession. The risk of error is thus lessened by shaking, and this is the preferred method. Add 25 ml of the dispersing-agent solution from a pipette to the second 1 L measuring cylinder and dilute with water exactly to the 1 L mark. Place this cylinder in the constant-temperature environment alongside the other cylinder. It is essential to check that dispersion is effective in each and every sample (see the last paragraph of 8.3.2). After at least 1 h, or when the cylinders and contents have reached the temperature of the environment, take both cylinders in turn and shake thoroughly to mix the contents. The cylinder containing the soil suspension should be turned end-over-end at least 30 times/min for 2 min. Replace both cylinders in the constant-temperature environment immediately.

At the moment that the cylinder with the soil suspension is replaced, start the stop clock, and gently remove the stoppers from both cylinders. Slowly immerse the hydrometer in the soil suspension to a position slightly below its floating position, and allow it to float freely (see the third paragraph of this subclause). The hydrometer shall be inserted into the cylinder in such a manner that it floats centrally in the cylinder. If there is a froth on the surface of the suspension so that it will be difficult to read the hydrometer scale, then add one or two drops of a surfactant (8.3.3 and its note, and the note to B.4.4). Take hydrometer readings at the upper rim of the meniscus after periods of 0,5 min, 1 min, 2 min and 4 min. Record these readings as  $d'$  in Table B.1.

**Table B.1 — Hydrometer test data**

Date	Time	Elapsed time, $t^a$	Temperature, $T$ °C	Reading, $d'$	$d' + z_m = d$	$z$ mm	$d_p$ mm	$d' - d'_0 = d_m$	$P$
<p>where</p> <p><math>t</math> is the elapsed time since the start of sedimentation;</p> <p><math>T</math> is the temperature of the suspension at time <math>t</math>, in °C;</p> <p><math>d'</math> is the hydrometer reading in the suspension at the upper part of the meniscus, consisting of the decimal part only, with the decimal point moved three places to the right; for example, a reading of 1,012 5 would be recorded as a <math>d'</math> value of 12,5;</p> <p><math>z_m</math> is the meniscus correction, in mm;</p> <p><math>z</math> is the effective depth, in mm, corresponding to <math>d'</math>, obtained from the calibration curve;</p> <p><math>d_p</math> is the equivalent spherical diameter of the particle, in mm;</p> <p><math>d'_0</math> is the hydrometer reading at the upper rim of the meniscus in the dispersant solution;</p> <p><math>P</math> is the proportion of material below a given value of <math>d_p</math>.</p> <p><sup>a</sup> The equation in Clause B.6 will give this time in seconds. It is strongly recommended that these times be converted to minutes (and hours, where necessary) to reduce the possibilities of error in reading long time intervals in seconds.</p>									

Stokes's Law applies to separate spheres falling in a large body of liquid, and is not applicable to a concentrated suspension. Experience has shown that, if the mass of material in suspension is not too large, mutual interference between particles is not a serious problem. However, soils rich in bentonite or other swelling minerals can gel to a greater or lesser degree at concentrations much lower than those suggested for this analysis. A hydrometer reading which does not change with time can be an indication of this problem. The analysis should be repeated with a smaller amount of soil. Very marked changes in hydrometer readings with time can indicate unusual distributions of particles of different sizes within the sedimenting material. In such cases, the hydrometer might not be a reliable method for the determination of particle size distribution, and the pipette method will then have to be used (Reference [1] in the Bibliography).

Remove the hydrometer gently after each reading, rinse with water, dry, and place it in the cylinder containing the dispersant, using the same technique as for the other cylinder. Note the reading on the scale at the top of the meniscus ( $d'_0$ ). Re-insert the hydrometer gently into the soil suspension and take, and record, readings after periods of 8 min, 30 min, 2 h, 8 h and 24 h from the start of sedimentation, and twice during the following day if appropriate. The test shall be continued until the percentage finer than 0,002 mm can be determined. In most cases, if the correct amount of soil has been used, this should be within about 24 h. Not less than three readings shall be taken during this period, in order that a reliable distribution curve can be constructed. The precise times are not critical, provided that the times are recorded exactly. The hydrometer shall be inserted into the suspension about 15 s before a reading is taken, great care being taken to disturb the suspension as little as possible. Record the temperature once during the first 15 min, and then after every subsequent reading. Read to an accuracy of  $\pm 0,5$  °C. If the temperature of the environment varies by more than 1 °C during the period over which measurements are made, take another hydrometer reading in the cylinder with the dispersant.

## B.6 Calculation and expression of results

Calculate the true hydrometer reading,  $d$ , in millimetres, from the equation:

$$d = d' + z_m$$

where

$z_m$  is the meniscus correction;

$d'$  is the observed hydrometer reading.

Obtain the effective depth,  $z$ , from the hydrometer calibration curve.

Stokes's Law (Clause 4) can be rewritten as:

$$d_p^2 = 18\eta z / (\rho_s - \rho_w) g t$$

where

$d_p$  is the particle diameter, in millimetres;

$\eta$  is the dynamic viscosity of water at the test temperature, in millipascals per second, as shown in Table B.2;

$z$  is the effective depth at which the density of the suspension is measured, in millimetres;

$\rho_s$  is the particle density, assumed to be 2,65 Mg/m<sup>3</sup> (see the note in Clause 4);

$\rho_w$  is the density of the suspension liquid, taken to be 1,000 0 Mg/m<sup>3</sup> (see the note in Clause 4);

$g$  is the acceleration due to gravity, taken to be 981 cm/s<sup>2</sup>;

$t$  is the elapsed time, in seconds.

It is recommended that, for routine use, these values be recalculated as minutes and/or hours, so as to lessen the risk of operator error.

**Table B.2 — Viscosity ( $\eta$ ) of water**

Temperature °C	$\eta$ mPa/s
20	1,002
21	0,978
22	0,955
23	0,933
24	0,911
25	0,891
26	0,871
27	0,852
28	0,833
29	0,815
30	0,798

Calculate and record the values of  $d_p$  (see Table B.1). Calculate the modified hydrometer reading,  $d_m$ , from the equation:

$$d_m = d' - d_o'$$



where  $d_o'$  is the hydrometer reading at the upper rim of the meniscus in the dispersant cylinder.

If the density of the solution in the cylinder containing the dispersant is less than 1,000 0 Mg/m<sup>3</sup>, the value of  $d_o'$  will be negative, e.g. a value of 0,999 8 Mg/m<sup>3</sup> will give a  $d_o'$  value of 22 (Reference [3] in the Bibliography). Enter the value of  $d_m$  in the appropriate column of Table B.1.

Calculate the proportion ( $P$ ) by mass of particles smaller than the corresponding equivalent spherical diameter,  $d_p$  (in millimetres), from the equation:

$$P = [d_m / m_t] \cdot [\rho_s / (\rho_s - 1)]$$

where  $m_t$  is the total mass of the dry pretreated soil, in grams.

**NOTE** The total mass of the original soil after pretreatment is obtained by correcting the mass of soil ( $m_s$ ; see 8.5) for the organic matter content, determined according to ISO 10694. This correction procedure is not without its potential errors, but these are seen as preferable to the errors which can arise from inadequate dispersion of oven-dried soil.

Enter the proportion of soil, to two significant figures, corresponding to each value of  $d_p$  in the appropriate part of Table B.1. Express the results of this analysis as a table and as a cumulative distribution curve, as proportions or percentages, as appropriate.

## B.7 Test report

The test report shall conform to Clause 10. In addition, it shall state that the hydrometer method was used, the reference number of the hydrometer used, and the value of the particle density used (stating whether this is an assumed or measured value).

## Bibliography

- [1] ISO 10694:1995, *Soil quality — Determination of organic and total carbon after dry combustion (elementary analysis)*
- [2] ALLEN, T. 1990. *Particle Size Measurement* (4th Edition). Chapman and Hall, London
- [3] GEE, G.W. and BAUDER, J.W. 1986. *Particle Size Analysis*. In: *Methods of Soil Analysis, Part 1* (2nd edition) (ed. A. Klute), pp. 383-411. American Society of Agronomy, Madison, Wisconsin
- [4] HEAD, K.H. 1992. *Manual of Soil Laboratory Testing: Volume I (2nd edition) — Soil classification and compaction tests*. Pentech Press, London
- [5] KILMER, V.J. 1960. The estimation of free iron oxides in soils. *Proc. Soil Sci. Soc. Am.*, **24**, pp. 420-421
- [6] LIDE, D.R. (ed.) 1990. *CRC Handbook of Chemistry and Physics*: 71st edition, pp. 6-8. CRC Press, Boca Raton, USA
- [7] LOVELAND, P.J. and WHALLEY, W.R. 1991. *Particle Size Analysis*. In: *Soil Analysis: Physical Methods* (eds K.A. Smith and C.E. Mullins), pp. 271-328. Marcel Dekker, New York
- [8] WINCHELL, A.W. 1951. *Elements of Optical Mineralogy, Part 1: Descriptions of Minerals*, pp. 246. John Wiley and Sons, New York
- [9] YAALON, D.H. 1976. "Calgon" no longer suitable. *J. Soil Sci. Soc. Am.*, **40**, p. 333
- [10] YOSHINAGA, N. and AOMINE, S. 1962. Allophane in some Ando Soils. *Soil Sci. Plant Nutrition*, **8**, pp. 6-13



---

---

**ICS 13.080.20**

Price based on 34 pages

*This page has been intentionally left blank*

---

## BSI - British Standards Institution

BSI is the independent national body responsible for preparing British Standards. It presents the UK view on standards in Europe and at the international level. It is incorporated by Royal Charter.

### Revisions

British Standards are updated by amendment or revision. Users of British Standards should make sure that they possess the latest amendments or editions.

It is the constant aim of BSI to improve the quality of our products and services. We would be grateful if anyone finding an inaccuracy or ambiguity while using this British Standard would inform the Secretary of the technical committee responsible, the identity of which can be found on the inside front cover. Tel: +44 (0)20 8996 9000. Fax: +44 (0)20 8996 7400.

BSI offers members an individual updating service called PLUS which ensures that subscribers automatically receive the latest editions of standards.

### Buying standards

Orders for all BSI, international and foreign standards publications should be addressed to Customer Services. Tel: +44 (0)20 8996 9001. Fax: +44 (0)20 8996 7001 Email: [orders@bsigroup.com](mailto:orders@bsigroup.com) You may also buy directly using a debit/credit card from the BSI Shop on the Website <http://www.bsigroup.com/shop>

In response to orders for international standards, it is BSI policy to supply the BSI implementation of those that have been published as British Standards, unless otherwise requested.

### Information on standards

BSI provides a wide range of information on national, European and international standards through its Library and its Technical Help to Exporters Service. Various BSI electronic information services are also available which give details on all its products and services. Contact Information Centre. Tel: +44 (0)20 8996 7111 Fax: +44 (0)20 8996 7048 Email: [info@bsigroup.com](mailto:info@bsigroup.com)

Subscribing members of BSI are kept up to date with standards developments and receive substantial discounts on the purchase price of standards. For details of these and other benefits contact Membership Administration. Tel: +44 (0)20 8996 7002 Fax: +44 (0)20 8996 7001 Email: [membership@bsigroup.com](mailto:membership@bsigroup.com)

Information regarding online access to British Standards via British Standards Online can be found at <http://www.bsigroup.com/BSOL>

Further information about BSI is available on the BSI website at <http://www.bsigroup.com>

### Copyright

Copyright subsists in all BSI publications. BSI also holds the copyright, in the UK, of the publications of the international standardization bodies. Except as permitted under the Copyright, Designs and Patents Act 1988 no extract may be reproduced, stored in a retrieval system or transmitted in any form or by any means – electronic, photocopying, recording or otherwise – without prior written permission from BSI.

This does not preclude the free use, in the course of implementing the standard, of necessary details such as symbols, and size, type or grade designations. If these details are to be used for any other purpose than implementation then the prior written permission of BSI must be obtained.

Details and advice can be obtained from the Copyright and Licensing Manager. Tel: +44 (0)20 8996 7070 Email: [copyright@bsigroup.com](mailto:copyright@bsigroup.com)