

BS ISO 11096:2011



BSI Standards Publication

Road vehicles — Pedestrian protection — Impact test method for pedestrian thigh, leg and knee

bsi.

...making excellence a habit.™

National foreword

This British Standard is the UK implementation of ISO 11096:2011. It supersedes BS ISO 11096:2002 which is withdrawn.

The UK participation in its preparation was entrusted to Technical Committee AUE/15, Safety related to vehicles.

A list of organizations represented on this committee can be obtained on request to its secretary.

This publication does not purport to include all the necessary provisions of a contract. Users are responsible for its correct application.

© BSI 2011

ISBN 978 0 580 74394 8

ICS 43.020

Compliance with a British Standard cannot confer immunity from legal obligations.

This British Standard was published under the authority of the Standards Policy and Strategy Committee on 30 September 2011.

Amendments issued since publication

Date	Text affected
------	---------------

INTERNATIONAL STANDARD

BS ISO 11096:2011

ISO
11096

Second edition
2011-09-15

Road vehicles — Pedestrian protection — Impact test method for pedestrian thigh, leg and knee

*Véhicules routiers — Protection des piétons — Méthode d'essai de
choc pour la cuisse, la jambe inférieure et le genou des piétons*



Reference number
ISO 11096:2011(E)

© ISO 2011



COPYRIGHT PROTECTED DOCUMENT

© ISO 2011

All rights reserved. Unless otherwise specified, no part of this publication may be reproduced or utilized in any form or by any means, electronic or mechanical, including photocopying and microfilm, without permission in writing from either ISO at the address below or ISO's member body in the country of the requester.

ISO copyright office
Case postale 56 • CH-1211 Geneva 20
Tel. + 41 22 749 01 11
Fax + 41 22 749 09 47
E-mail copyright@iso.org
Web www.iso.org

Published in Switzerland

Contents

Page

Foreword	iv
Introduction.....	v
1 Scope	1
2 Normative references	1
3 Terms and definitions	1
3.1 Legform impactor	1
3.2 Vehicle	2
4 Test equipment	3
4.1 Impact test site	3
4.2 Legform impactor	4
4.3 Propulsion system	4
4.4 Applicable vehicles	4
5 Requirements.....	4
5.1 Legform impactor	4
5.2 Propulsion of legform impactor.....	5
5.3 Legform impactor setting	5
5.4 Test temperature	6
6 Preparation of test vehicle	6
7 Test conditions	6
7.1 Atmospheric conditions	6
7.2 Angle of impact.....	6
7.3 Impact point	6
7.4 Impact velocity.....	7
8 Measurement requirements for legform impactor	7
8.1 Data acquisition.....	7
8.2 Legform impactor data.....	7
8.3 Test specimen.....	7
Annex A (normative) Biofidelic performance characteristics	8
Annex B (normative) Legform impactor certification	13
Annex C (informative) Data sheet.....	14
Annex D (informative) Comments on the test procedure	17
Bibliography.....	21

Foreword

ISO (the International Organization for Standardization) is a worldwide federation of national standards bodies (ISO member bodies). The work of preparing International Standards is normally carried out through ISO technical committees. Each member body interested in a subject for which a technical committee has been established has the right to be represented on that committee. International organizations, governmental and non-governmental, in liaison with ISO, also take part in the work. ISO collaborates closely with the International Electrotechnical Commission (IEC) on all matters of electrotechnical standardization.

International Standards are drafted in accordance with the rules given in the ISO/IEC Directives, Part 2.

The main task of technical committees is to prepare International Standards. Draft International Standards adopted by the technical committees are circulated to the member bodies for voting. Publication as an International Standard requires approval by at least 75 % of the member bodies casting a vote.

Attention is drawn to the possibility that some of the elements of this document may be the subject of patent rights. ISO shall not be held responsible for identifying any or all such patent rights.

ISO 11096 was prepared by Technical Committee ISO/TC 22, *Road vehicles*, Subcommittee SC 10, *Impact test procedures*.

This second edition cancels and replaces the first edition (ISO 11096:2002), which has been technically revised.

Introduction

The intent of this International Standard is to help standardize the pedestrian leg impactor test method that will allow a test organization to use the results from pedestrian impact tests conducted by other test organizations.

The method is based on the simulated impact of a motor vehicle on an adult pedestrian. It is anticipated that biomechanical data for children will later be studied in order to determine the potential for child pedestrian protection. Research suggests that safety improvements in vehicles derived from such pedestrian impact tests would also be beneficial to motorcyclists and bicyclists (see Annex D).

Road vehicles — Pedestrian protection — Impact test method for pedestrian thigh, leg and knee

1 Scope

This International Standard specifies a test method for simulating the lateral impact between the front of a passenger vehicle or light truck vehicle derived from passenger cars (as defined in ISO 3833) and an adult pedestrian.

The test method addresses the reduction of pedestrian thigh, leg and knee injuries. It is not applicable to testing for, or the evaluation of, injuries to other pedestrian body regions, nor does it directly cover the potential risk of injury to children or human soft tissue. It is not applicable to vehicles with deployable devices designed for activation in the event of impact with a pedestrian.

2 Normative references

The following referenced documents are indispensable for the application of this document. For dated references, only the edition cited applies. For undated references, the latest edition of the referenced document (including any amendments) applies.

ISO 1176, *Road vehicles — Masses — Vocabulary and codes*

ISO 3784, *Road vehicles — Measurement of impact velocity in collision tests*

ISO 3833, *Road vehicles — Types — Terms and definitions*

ISO 6487, *Road vehicles — Measurement techniques in impact tests — Instrumentation*

ISO/TR 15766, *Road vehicles — Pedestrian protection — Targets for the assessment of the biofidelity of pedestrian-leg test devices*

3 Terms and definitions

For the purposes of this document, the terms and definitions given in ISO 1176 and ISO 3833, and the following apply.

3.1 Legform impactor

3.1.1

knee joint

mechanical joint of a legform impactor with deformable elements simulating a human knee in lateral impact only

3.1.2

thigh

mechanical components above the legform impactor knee joint

3.1.3

leg

mechanical components below the legform impactor knee joint

3.1.4

knee joint centre

centre of the bending part of a knee joint's deformable element before deformation

3.1.5

valgus angle

angle of the knee joint in abduction

3.2 Vehicle

3.2.1

impact point

point on the vehicle at which initial contact occurs

3.2.2

front face

foremost part of the front of the vehicle, and that most likely to strike the pedestrian's leg

3.2.3

corner

extremity on either side of the front face located at the point at which a vertical plane, set at 60° to the centreline of the vehicle, comes in contact with, and is tangential to, the outer surface of the front face

NOTE See Figure 1.

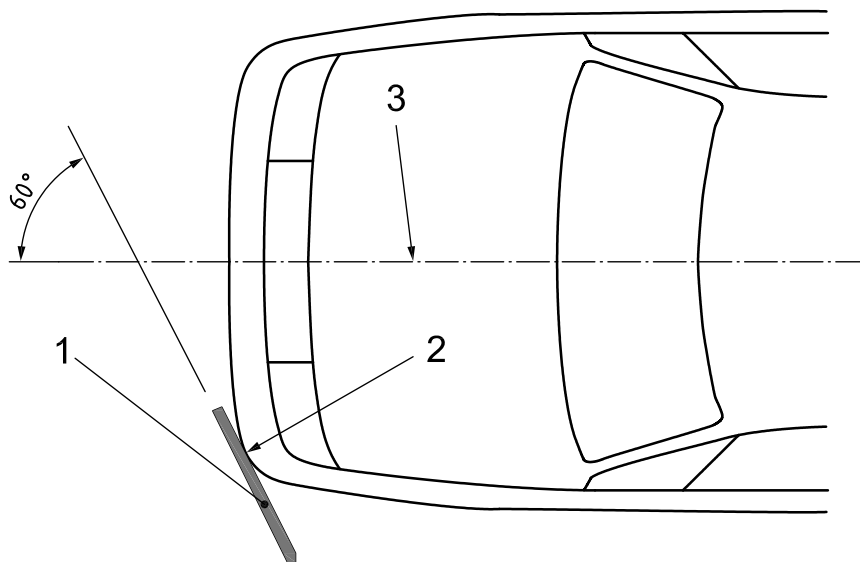

Key

- 1 straight edge
- 2 corner of front face
- 3 vehicle centreline

Figure 1 — Corner of front face

4 Test equipment

4.1 Impact test site

The impact test site shall consist of a flat, smooth and hard surface with a slope not exceeding 1 % under the test vehicle, as shown in Figure 2.

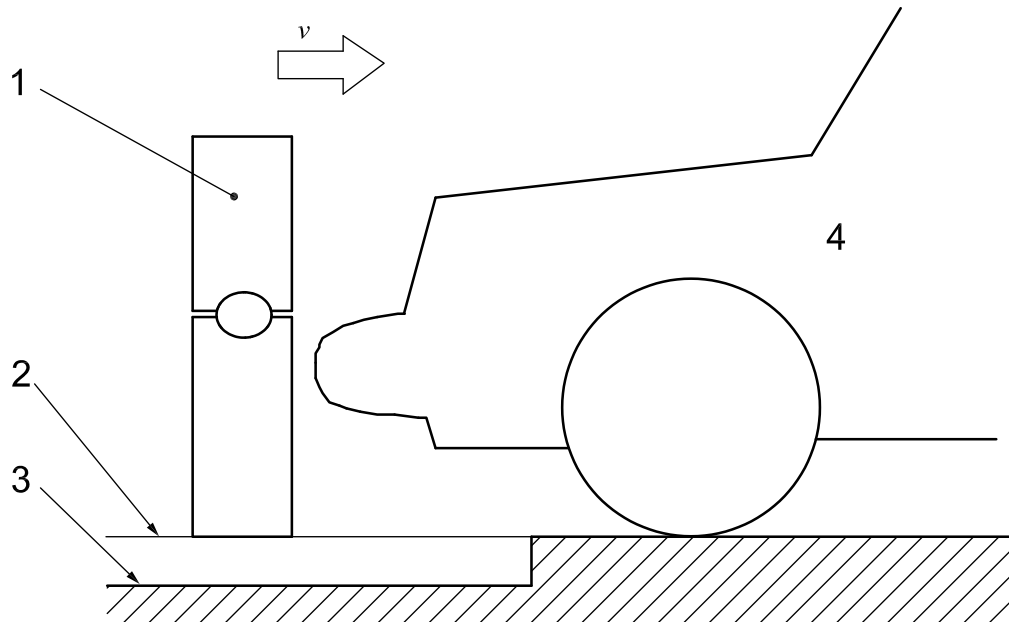

Key

- 1 impactor
- 2 ground reference plane (GRP)
- 3 ground
- 4 vehicle

Figure 2 — Impact test site

4.2 Legform impactor

The legform impactor shall be a device sensitive to the characteristics of the front face, with a knee joint in accordance with the model specified in 5.1.1 and shown in Figure 3.

Dimensions in millimetres

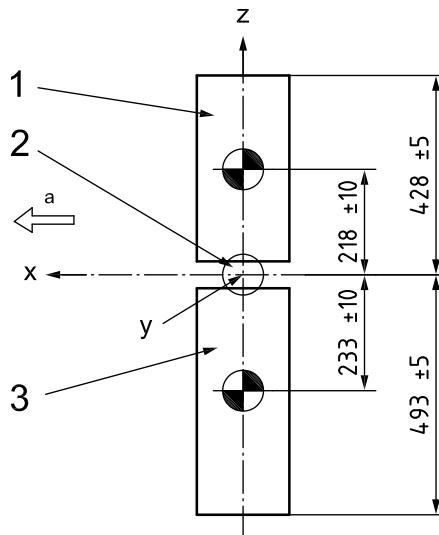

Key

- 1 thigh
- 2 knee joint
- 3 leg
- ^a Trajectory.

Figure 3 — Legform impactor

4.3 Propulsion system

The legform impactor shall be propelled by a propulsion system in accordance with 5.2.

4.4 Applicable vehicles

The test method is applicable to passenger cars and light commercial vehicles of up to 3,5 tonnes.

5 Requirements

5.1 Legform impactor

5.1.1 Physical properties

The dimensions (see Figure 3) and mass distribution of the legform impactor used in the test are based on a 50th percentile male^[1]. They and the other physical properties of the legform impactor shall be as follows.

- a) Leg length between the bottom and the knee joint centre: (493 ± 5) mm.
- b) Thigh length between the knee joint centre and the top: (428 ± 5) mm.
- c) Centre of gravity of leg from the knee joint centre: (233 ± 10) mm.

- d) Centre of gravity of thigh from the knee joint centre: (218 ± 10) mm.
- e) Total legform impactor mass: $(13,4 \pm 0,1)$ kg.
- f) Thigh mass including skin and foam: $(8,6 \pm 0,1)$ kg.
- g) Leg mass including skin and foam: $(4,8 \pm 0,1)$ kg.
- h) Moment of inertia around y axis of leg: $(0,12 \pm 0,001)$ kg m².
- i) Moment of inertia around y axis of thigh: $(0,127 \pm 0,001)$ kg m².
- j) An adaptor may be fitted to the top of the thigh to permit the attachment of the legform impactor to the propulsion system. If used, the thigh with adaptor shall still comply with the thigh requirement of mass, centre of gravity and moment of inertia.
- k) There shall be a simulation of flesh or skin on the outer surface of the legform impactor. This material shall be human-like.

5.1.2 Shape of legform impactor

The shape of the legform impactor shall be cylindrical. The outer diameter of the thigh and that of the leg shall be the same: (120 ± 10) mm, including a “flesh” thickness of (30 ± 5) mm.

5.1.3 Biofidelic performance characteristics

The legform impactor shall meet the biofidelic performance targets given in Annex A.

5.1.4 Certification of legform impactor

The legform impactor shall meet the certification requirements given in Annex B.

5.1.5 Calibration of legform impactor deformable elements

Once the structural design of the deformable knee element meeting the requirements specified in 5.1.3 and 5.1.4 is completed, the designer of the legform impactor shall provide a calibration test procedure in which each batch of deformable knee elements shall be checked to see if their performance is acceptable. Such a calibration test procedure may be applied statically if this test proves that the characteristics of the batch are similar to those of the original design. The response adopted as a requirement for a calibration test should allow for a reasonable variation in production.

5.2 Propulsion of legform impactor

The legform impactor shall be propelled in free flight into the stationary test vehicle. The method of legform impactor propulsion is at the discretion of the test office; however, the knee joint should be supported during legform impactor acceleration. The trajectory of the legform impactor shall be parallel to the ground within $\pm 6^\circ$ at impact with the vehicle, and its angular velocity at this time shall be less than $50^\circ/\text{s}$. Because of the effect of gravity and depending on the length of free flight, this may require that the trajectory of the legform impactor at the time of its release from the propulsion system be at an angle above horizontal. There shall be no contact between the legform impactor and the propulsion system during impact with the vehicle.

5.3 Legform impactor setting

5.3.1 The legform impactor shall be straight, and vertical in pitch and roll at the time of impact (see Figure 2). The tolerances for pitch, roll and yaw shall be $\pm 5^\circ$.

5.3.2 The lower end of the legform impactor shall be at or within 10 mm of the level of the ground reference plane (GRP) at impact with the vehicle. The legform impactor shall not come into contact with the ground during impact (see Figure 2).

5.4 Test temperature

The legform impactor shall have a temperature of (20 ± 5) °C at the time of impact. However, a narrower range may be required to keep the performance of the legform impactor within the specified limits.

6 Preparation of test vehicle

6.1 Either a complete vehicle or cut-body shall be used for the test. All parts of the vehicle structure and components that could be involved in a pedestrian leg impact shall be in place.

6.2 The ground clearance of the test vehicle or cut-body shall be set to simulate that of an actual vehicle with tyres inflated to the nominal tyre pressure specified by the manufacturer. Spacers may be placed under the tyres in order to bring the vehicle to a height that will allow the free flight of the legform impactor.

NOTE Testing with or without numberplate (licence plate) is at the discretion of the test laboratory or government body. The material and size of the plate may be standardized during a given test programme when testing a vehicle with plate.

6.3 For tests of a complete vehicle, the suspension shall be set to the normal ride height attained at the test impact velocity (specified in the relevant laws and regulations or by the concerned government agencies) and shall include the complete vehicle kerb mass (ISO-M06) in accordance with ISO 1176, with one adult male 50th percentile dummy or an equivalent mass placed on the driver's seat, and with one adult male 50th percentile dummy or an equivalent mass placed on the passenger's seat.

6.4 For tests using a cut-body, the height of the body above the ground reference plane shall be the same as that of the complete vehicle loaded in accordance with 6.3.

6.5 The parking brake shall be applied, or the cut-body shall be securely mounted.

6.6 Sufficient time shall be allowed for the temperature (see 7.1) of all vehicle components to stabilize before testing.

7 Test conditions

7.1 Atmospheric conditions

Relative humidity, atmospheric pressure and temperature shall be measured at the time of the test and recorded in the test report.

7.2 Angle of impact

The direction of impact shall be parallel to the centreline of the vehicle, with the axis of the legform vertical at the time of first contact. The tolerance of the velocity vector of the impactor shall be $\pm 2^\circ$.

7.3 Impact point

Tests shall be made on the vehicle between the corners of the front face, with the centre of each impact a minimum of 60 mm inside each corner. Sufficient test points shall be selected to evaluate the vehicle structure. Test points on a single vehicle front face shall be separated by sufficient distance to preclude influence of pre-existing damage on subsequent impacts.

7.4 Impact velocity

7.4.1 General

The velocity at the time of impact shall be that specified in the appropriate test. The impact device used shall be capable of functioning while withstanding an impact velocity of up to 5,5 m/s.

7.4.2 Velocity measurement

The velocity of the legform impactor shall be measured at some point during the free flight before impact. The accuracy of velocity measurement shall be $\pm 0,1$ m/s.

8 Measurement requirements for legform impactor

8.1 Data acquisition

Data shall be acquired in accordance with ISO 6487.

8.2 Legform impactor data

Legform impactor data shall be recorded in accordance with Table 1.

8.3 Test specimen

The points tested shall be indicated in the test report.

Table 1 — Legform impactor data

Measurements ^a (items)	Location	Direction (axis)	Channel amplitude class (CAC) ^b	Channel filter class (CFC) Hz
(1) Valgus angle	Knee-joint centre	y	40°	180
(2) Bending moment	Knee-joint centre	y	1 000 Nm	180
(3) Shearing displacement	Knee-joint centre	x	20 mm	180
(4) Shearing force	Knee-joint centre	x	10 kN	180
(5) Contact force	Area of first contact	x	10 kN	180
^a Either (1) or (2) may be measured. Measuring item (5) is a recommendation. Either (3) or (4) may be measured.				
^b Electrical instrumentation measurement.				

Annex A (normative)

Biofidelic performance characteristics

A.1 General

This annex specifies the biofidelic performance characteristics of the legform impactors to be used in the test, as well as the test set-ups.

A.2 Test set-up

A.2.1 General

The individual test set-up is designed for obtaining both bending moment and shearing force.

A.2.2 Bending test

The specifications for the bending test shall be as follows.

Pre-loading mass, F :	40 kg
Loading device and support face:	50 mm × 150 mm
Padding block:	50 mm × 50 mm × 150 mm (for impactor) 25 mm × 50 mm × 150 mm (for support)
Dimensions:	$D = 904$ mm, $d_1 = 74$ mm, $d_2 = 400$ mm
Measurements:	Loading device acceleration (CFC 180) Loading device force (CFC 180) Loading device velocity at time of impact Medial support load (CFC 180)

A.2.3 Shearing test (see Figure A.2)

The specifications for the shearing test shall be as follows.

Pre-loading mass, F :	40 kg
Loading device and support face:	50 mm × 150 mm
Padding block:	50 mm × 50 mm × 150 mm (for impactor) 25 mm × 50 mm × 150 mm (for support)
Dimensions:	$D = 874$ mm, $d_1 = 45$ mm, $d_2 = 45$ mm, $d_3 = 103$ mm
Measurements:	Loading device acceleration (CFC 180) Loading device force (CFC 180) Loading device velocity at time of impact Medial support load (CFC 180)

Dimensions in millimetres

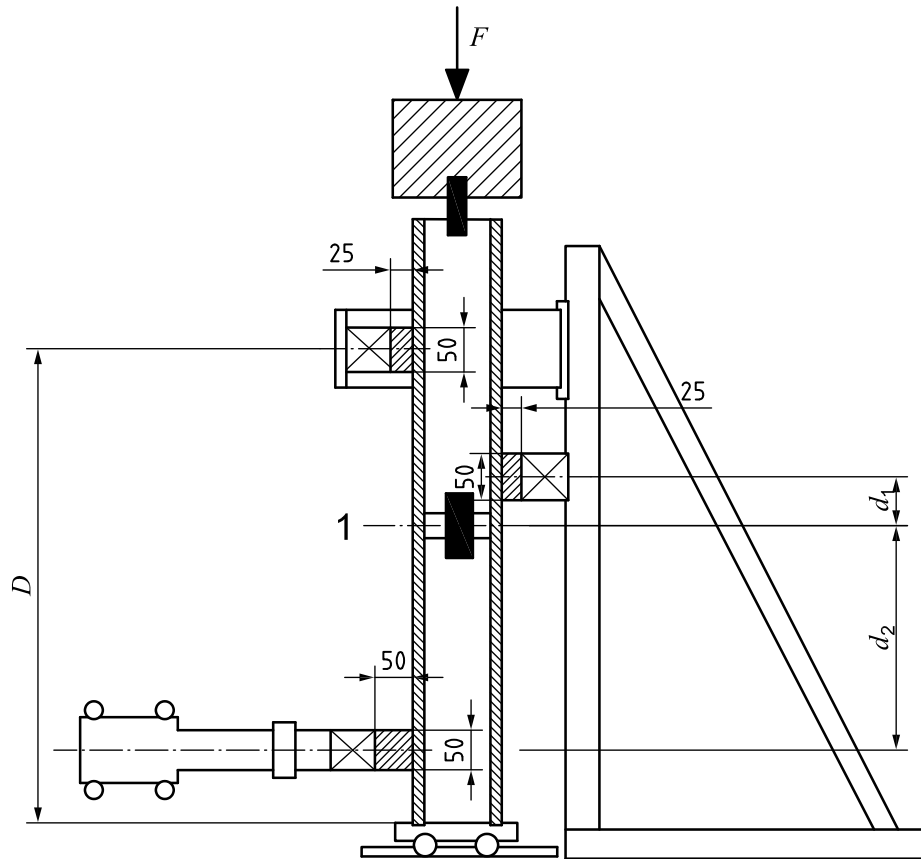

Key

- 1 knee joint centre

Figure A.1 — Test set-up — Dynamic bending moment

Dimensions in millimetres

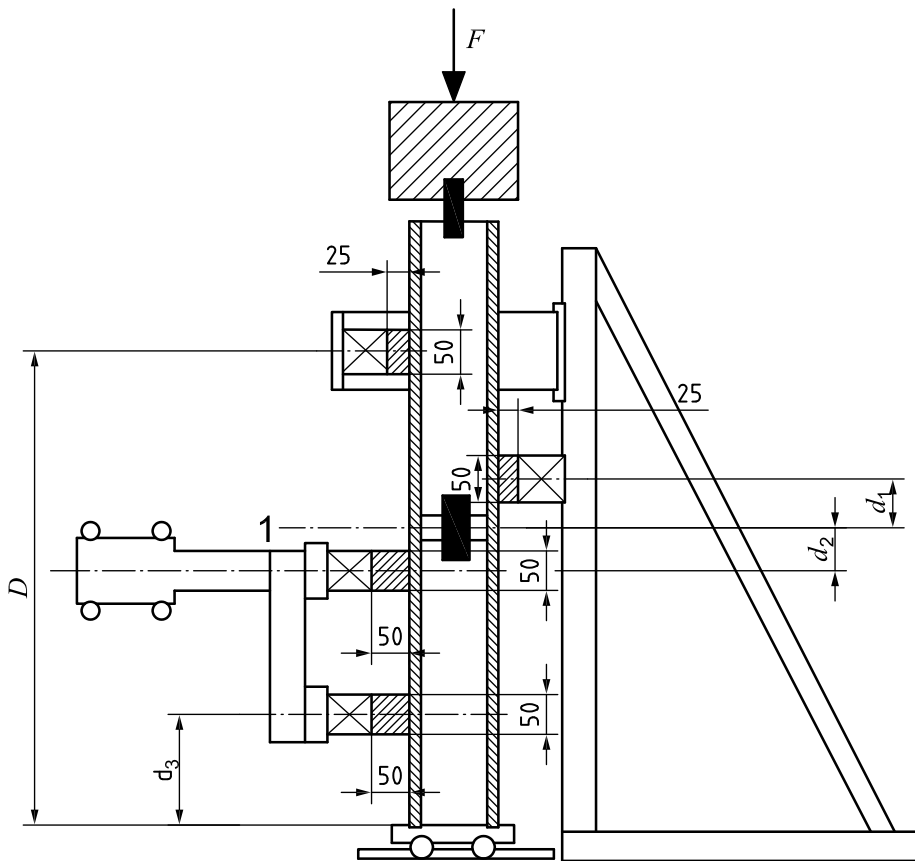

Key
1 knee joint centre

Figure A.2 — Test set-up — Dynamic shearing force

A.2.4 Padding dynamic characteristics

The dynamic characteristics of the Styrodur¹⁾ padding to be used in this test are shown in Figure A.3, based on compression between two flat plates.

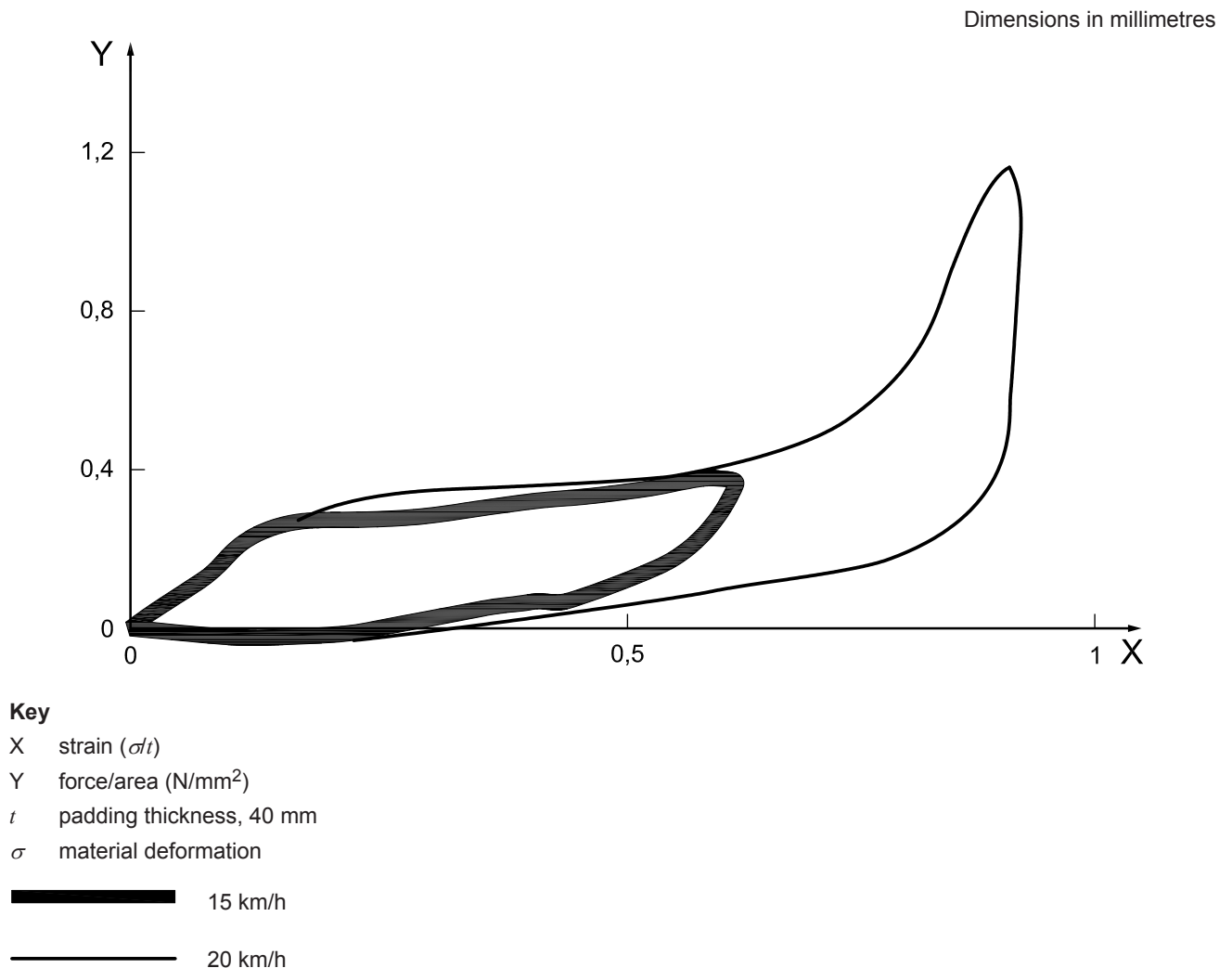

Figure A.3 — Padding dynamic characteristic at 15 km/h and 20 km/h

A.3 Performance

The bending characteristics of human legs are represented by the impact force at the ankle level. They are normalized and shown with impact velocity in Figure A.4 at 15 km/h and Figure A.5 at 20 km/h.

Shearing characteristics of human legs are represented by the force below the knee level. They are normalized and shown with impact velocity in Figure A.6 at 15 km/h.

1) Styrodur[®] is an example of a product available commercially. This information is given for the convenience of users of this International Standard and does not constitute an endorsement by ISO of this product.

Key
 X time (ms)
 Y impactor force (kN)
 —■— upper range
 —●— lower range
 ▨ biomechanical data

15 km/h corridor:

A (0, 0,1)	F (3, 0)
B (4, 2,5)	G (4, 1,5)
C (12, 0,7)	H (9, 0,1)
D (20, 0,4)	I (40, 0,1)
E (40, 0,4)	

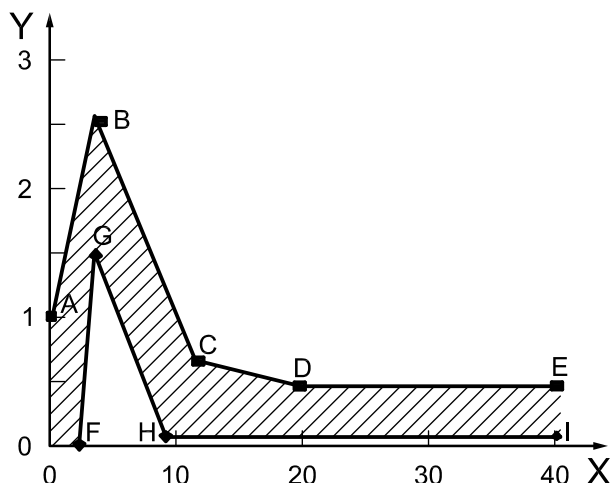

Figure A.4 — Force of bending test at 15 km/h

Key
 X time (ms)
 Y impactor force (kN)
 —■— upper range
 —●— lower range
 ▨ biomechanical data

20 km/h corridor:

A (0, 1,0)	E (40, 0,7)
B (4, 3,3)	F (3, 0)
C (11, 0,5)	G (8, 0,2)
D (30, 0,5)	H (4, 1,7)

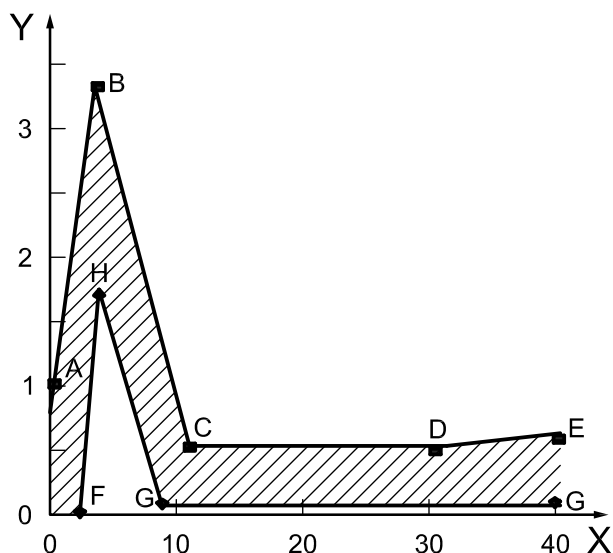

Figure A.5 — Force of bending test at 20 km/h

Key
 X time (ms)
 Y impactor force (kN)
 —■— upper range
 —●— lower range
 ▨ biomechanical data

15 km/h corridor:

A (0, 2,5)	G (40, 2,7)
B (5, 3,0)	H (3, 0)
C (10, 2,3)	I (5, 1,7)
D (15, 2,8)	J (10, 1,5)
E (20, 2,8)	K (25, 1,9)
F (35, 2,5)	L (40, 1,6)

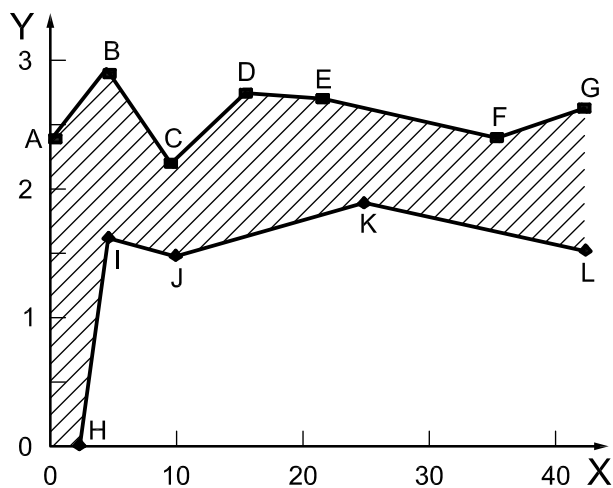

Figure A.6 — Force of shearing test at 15 km/h

Annex B (normative)

Legform impactor certification

B.1 Introduction

The performance of the legform impactor shall be measured using a dynamic impact or static test procedure, or both procedures. The purpose of this certification is to ensure that the legform impactor designed to respond to impact within the performance targets prescribed in Annex A is repeatable. Since this International Standard does not specify a particular test device, a detailed certification procedure is not given here as a requirement. An example of a concept for the certification procedure is given in Annex D. The certification procedure may include dynamic tests, static tests or both, as deemed appropriate by the manufacturer.

B.2 Test requirements

B.2.1 The legform impactor shall be tested in its complete, assembled condition including, but not limited to, any deformable elements, moving parts, “flesh” and measurement devices.

B.2.2 If the legform impactor includes a deformable element that is permanently altered in an impact, the deformable element shall be manufactured in batches or using a technique that ensures consistency of the deformable element's characteristics. A statistical sample of the batch of deformable elements shall be tested using the certification procedure. The number of elements selected from a batch shall be sufficient to establish consistency of performance of the batch, but there shall be at least one certification test for each thirty sets of deformable elements. A statistical criterion for acceptance shall be developed for the deformable elements.

B.2.3 An acceptable response criterion shall be developed to verify that the legform impactor meets the biofidelity requirements of Annex A. However, it is recognized that these criteria may be different from the detailed responses given in Annex A. The response of the legform impactor shall meet the certification criteria developed for the specific impactor.

B.2.4 The legform impactor shall be recertified as soon as one of the following occurs.

- a) A new batch of deformable elements is used.
- b) The legform impactor is disassembled, altered, or the channel amplitude class for any channel is exceeded or impacted in a way that could affect its response.
- c) The legform impactor has been subjected to 25 impact conditions.

The performance of the legform impactor may be certified at more frequent intervals if specified by the manufacturer or as deemed appropriate by the user.

Annex C (informative)

Data sheet

C.1 Specimen

State of specimen (complete vehicle or cut-body):

Cut location (in case of cut-body):

Manufacturer:

Type:

Year:

Serial No.:

Loading condition and location:

.....

Vehicle mass as tested: LF kg RF kg

 LR..... kg RR..... kg

 Total kg

Tyre pressure (cold): LF kPa RF kPa

 LR..... kPa RR..... kPa

Vehicle height (wheel arch): LF mm RF mm

 LR..... mm RR..... mm

C.2 Certification and calibration test results

Reference number certification:

Calibration:

C.3 Test condition

Description of the test site surface:

Manufacturer of legform impactor:

Ground clearance of legform impactor as tested:

Manufacturer of machine for propulsion of legform impactor:

Name of machine for propulsion of legform impactor:

Method of propulsion of legform impactor:

Temperature of test area:

Humidity of test area:

Atmospheric pressure:

C.4 Statement of results

Impact velocity: m/s

Impact area on the front face of a vehicle:

Impact locations on the legform (specify at first contact):

Maximum valgus angle during contact with the vehicle:degrees

Maximum bending moment during contact with the vehicle: N-m

Maximum shearing displacement during contact with the vehicle: mm

Maximum shearing force during contact with the vehicle: kN

Maximum contact force during contact with the vehicle: kN

Observation:

Laceration of outer skin, etc.:

.....

.....

Others:

.....

Any other optional measurements:

.....

C.5 Specification of sensors

Table C.1 — Type of sensor

No.	Location	Type of sensor				
		Direction	Range	Accuracy %	CAC	CFC Hz
1	x mm, z mm	Horizontal				
2	x mm, z mm	Vertical				

C.6 Test personnel and date

Name:

Section/department:

Company:

Date tested:

Annex D (informative)

Comments on the test procedure

D.1 Injury mechanisms

Injury mechanisms and tolerances of the lower limb have been investigated in various research institutes. The injury mechanisms selected by ISO/TC 22/SC 12/WG 6 (*Passive safety crash protection systems* subcommittee working group on *Performance criteria expressed in biomechanical terms*) as being appropriate for the lower limb are, as of October 1994, shearing and bending of the knee.

It is recognized that the injury mechanisms and tolerances upon which this test procedure is based are limited in scope and severity due to the limitations in the available knowledge of pedestrian lower limb impact. Firstly, this test procedure is based on data from a test conducted at velocities lower than those that could be expected in real world accidents (these test velocities are 16 km/h and 20 km/h), and lower limb injury commonly depends on impact velocity. Secondly, the procedure is based on data derived from laboratory tests rather than real world accidents situations. Thirdly, the application of the test data must be tempered due to the variability of the age and weight of the cadaver specimens used in the test.

D.2 Numberplate (license plate)

The presence of a numberplate (license plate), its position and the technique of mounting it on the front bumper can have a significant effect on the response of the legform impactor. Although the selection of testing with or without a plate is left to the user, the most representative data will include the plate. It is recognized that with the variability of numberplate requirements, multiple tests may be needed on a specific vehicle to determine the effect of these requirements on the response of the legform impactor. As related experience is accumulated, information may become available that will assist in identifying the significance of such plates.

D.3 Characteristics of legform impactor “flesh” and “skin”

It has been proposed that the response of a legform impactor can be affected by the characteristics of any “flesh” or “skin” on the impactor surface. The consensus of WG 2 is that this effect will be minimal with respect to the measured parameters. As such, it is recommended that the “flesh” be only human-like — Confor²⁾ foam currently used in the EuroSID-1 dummy or the flesh-like material used in the Part 572 Hybrid III dummies satisfies this recommendation.

D.4 Potential conflict in body component testing

At the enquiry stage of the ISO procedure for publication of an International Standard, a negative comment on this test procedure was submitted, indicating that optimized vehicles designed to satisfy ISO and European enhanced vehicle-safety committee (EEVC) requirements for reduced injury criteria based on one specific body component or size, such as an adult leg, might produce adverse effects on other body components or sizes, such as a child's torso.

2) Confor[®] is an example of a product available commercially. This information is given for the convenience of users of this International Standard and does not constitute an endorsement by ISO of this product.

At the time this test procedure was developed, there was no indication that this procedure or its application would have any adverse effect in respect of children, and no such conflict had been addressed by a test laboratory, until it was pointed out in a TNO (Netherlands Organization for Applied Scientific Research) report evaluating proposed EEVC subsystem test procedures by mathematical simulation. Two potential effects of vehicle modification have been discussed. The working group is concerned that no adverse effects result from the use of this test procedure. Pedestrian models used for the study need to be validated, and further studies are required to consolidate available information from dummy tests, cadaver tests, etc.

As long as test procedures are developed based on the body component test (i.e. subsystem test), there will theoretically continue to exist differences between the subsystem and full body tests, and the possibility of antinomy, incompatibility or conflict between adult and child tests. Further research and investigation is needed to explain the differences and possible conflicts between the test methods.

The working group asks to be advised of the results of any test suggesting the existence of conflict.

Every precaution is intended to be taken in order to be absolutely certain that the procedures developed for the adult legform test do not produce any adverse effects on other body components or sizes. It had been the group's intent in developing the adult legform impact test to also bring benefit to children. Since there is presently no test procedure available for pedestrian protection, the publication of this test procedure is expected to benefit all pedestrians including children.

However, if this test should prove to produce any conflict, it should be kept in mind that ISO procedures include provisions for revising, updating and refining already published documents, whenever improvements become available. Moreover, if such conflict were to be identified, other provisions would also permit the working group to initiate a new work item specifically dealing with the protection of the child torso.

D.5 Cyclists

Available information shows that vehicle structures that produce minimal injury to pedestrians are likewise beneficial to motorcyclists and bicyclists^[2]. Use of this test procedure will identify ways of helping reduce injury to motorcyclists and bicyclists.

D.6 Certification test set-up for legform impactor

The legform impactor, including "flesh", is attached to a pendulum arm as shown in Figure D.1. The pendulum arm is attached to the standard part 572 neck bending rig, replacing the standard neck pendulum arm, so that the centre of the knee joint is suspended (1630 ± 10) mm below the rotation axis of the pendulum arm. The centre of a honeycomb barrier [aluminium hexcell $(28,8 \pm 2,4)$ kg/m³ or any similar material with compressive strength of (896 ± 34) kPa in the direction of the application of force], 165 mm long, 105 mm wide and 50 mm thick, is placed 1 775 mm below the rotation axis of the pendulum arm. The honeycomb is fixed to a rigid support located (75 ± 1) mm from a vertical plane through the rotation axis of the pendulum arm (see Figure D.1). A 0,8 mm thick, 170 mm long and 110 mm wide aluminium plate is placed in front of the honeycomb in order to avoid damage to the legform impactor covering.

The pendulum arm should have a mass of $(15,4 \pm 0,1)$ kg and a moment of inertia about the pendulum arm rotation axis of $(8,0 \pm 0,1)$ kg/m². The pendulum arm length should be $(1\ 250 \pm 10)$ mm from the rotation axis and the centre of gravity should be located (555 ± 10) mm from the rotation axis.

D.7 Injury mechanisms

Dimensions in millimetres

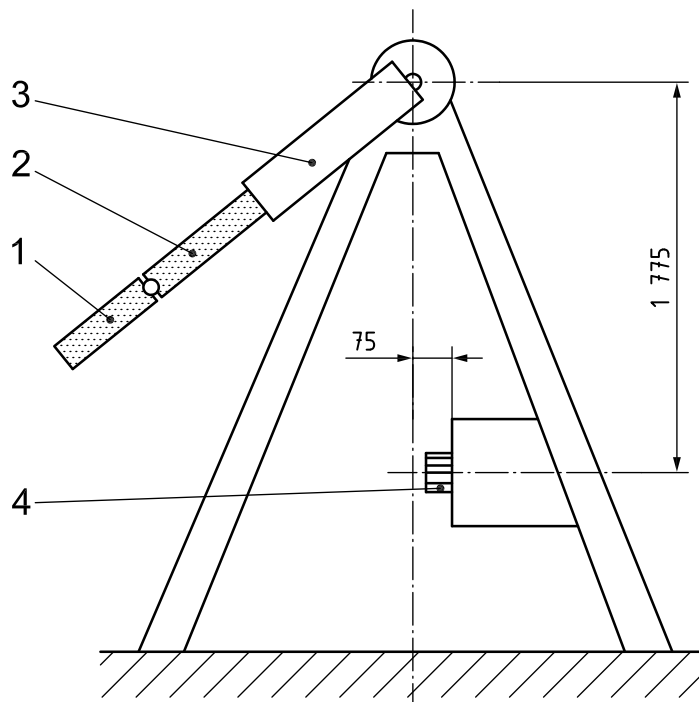

Key

- 1 leg
- 2 thigh
- 3 pendulum arm
- 4 honeycomb (see D.6 for dimensions)

Figure D.1 — Certification test set-up for legform impactor

See Figure D.2 for a summary of leg and knee injury mechanisms.

Dimensions in millimetres

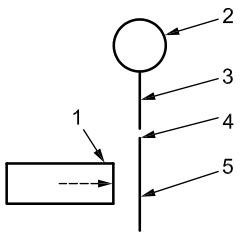
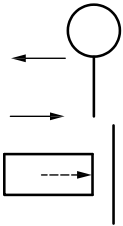
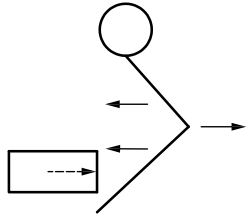
Phase	Contact injury	Shearing injury	Bending injury
Mode	 <p>Key 1 bumper 2 upper body 3 femur 4 knee 5 leg</p>		 <p>Influence of upper mass?</p>
Injury	Soft tissue (vessel) Nerves Local bone fracture (near impact point)	Ligament (avulsion of MCL, LCL, ACL; partial rupture, total rupture) Partial bone fracture of femur	Ligament (avulsion of LCL, ACL, PLC; partial rupture, total rupture) Condyles fracture of femur
Force measured	Contact point Contact force Contact pressure	Shearing force and/or deformation Bending moment and deformation	Bending moment transfered through knee
	Chalmer's, Ref. 5 Porsche, Ref. 7 Adelaide's, Ref. 2	Chalmer's, Ref. 5 INRETS, Ref. 10	Chalmer's, Ref. 5 TRRL, Ref. 1 INLETS, Ref. 8, Ref. 3

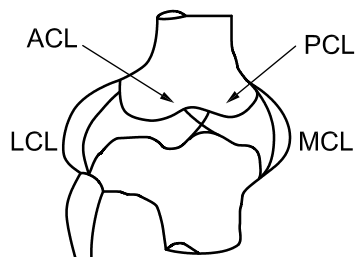

- MCL Medical collateral ligament
- LCL Lateral collateral ligament
- ACL Anterior cruciate ligament
- PCL Posterior cruciate ligament

Figure D.2 — Injury mechanisms of leg and knee

Bibliography

- [1] ROBBINS, D.H., *Anthropometry of Motor Vehicle Occupants*, Vol. 2, NHTSA Contract DTNH22-80-C-07502 Pub. 1985
- [2] JANSSEN, E.G., *Experimental and Mathematical Simulation of Pedestrian/Vehicle and Cyclist/Vehicle*, 10th ESV Conference, Oxford, 1985
- [3] FOWLER, J.E. and HARRIS, J., *Practical Vehicle Design for Pedestrian Protection*, Proceedings, Ninth ESV. Kyoto, Japan, 1982
- [4] GIBSON, T.J., HINRICHS, R.W. and MCLEAN, A.J., *Pedestrian Head Impacts: Development and Validation of a Mathematical Model*, Proceedings, 1986 IRCOBI. Zurich, Switzerland, 1986
- [5] NYQUIST, G.W. et. al., *Tibia Bending: Strength and Response*, Proceedings, 29th Stapp Car Crash Conference. SAE Paper No. 851728
- [6] SNIDER, J.N, FULLER, P.M. and WASSERMAN, J.F., *The Response of the Human leg to Impact Loading*, Proceedings, 1988 IRCOBI. Bergish Gladbach, W. Germany, 1988
- [7] KAJZER, K, *Bumper System Evaluation Using an Experimental Pedestrian Dummy*, Proceedings, Twelfth ESV, Goteborg, Sweden, 1989
- [8] ALDMAN, B. et. al., *An Experimental Model System for the study of leg and Knee Injuries in Car Pedestrian Accidents*, Proceedings, Eighth ESV, Wolfsburg, W. Germany, 1980
- [9] HOEFS, R. and HEINZ, M., *A Bumper for Both Pedestrian and Vehicle Body Protection: A Contradiction in Terms or a Soluble Conflict?* Proceedings, Eleventh ESV. Washington, D.C. 1987
- [10] CESARI, D. et. al., *Mechanisms Producing Lower Extremity Injuries in Pedestrian Accident Situations*, 1989 AAAM
- [11] KAJZER, J. et. al., *Response of the Knee Joint in Lateral Impact Effect of Shearing Loads*, 1990 RCOBI
- [12] CESARI, D. et. al, *Subsystem Test for Pedestrian leg and Knee Protection*, Proceedings, 13th ESV, 1991

British Standards Institution (BSI)

BSI is the national body responsible for preparing British Standards and other standards-related publications, information and services.

BSI is incorporated by Royal Charter. British Standards and other standardization products are published by BSI Standards Limited.

About us

We bring together business, industry, government, consumers, innovators and others to shape their combined experience and expertise into standards-based solutions.

The knowledge embodied in our standards has been carefully assembled in a dependable format and refined through our open consultation process. Organizations of all sizes and across all sectors choose standards to help them achieve their goals.

Information on standards

We can provide you with the knowledge that your organization needs to succeed. Find out more about British Standards by visiting our website at bsigroup.com/standards or contacting our Customer Services team or Knowledge Centre.

Buying standards

You can buy and download PDF versions of BSI publications, including British and adopted European and international standards, through our website at bsigroup.com/shop, where hard copies can also be purchased.

If you need international and foreign standards from other Standards Development Organizations, hard copies can be ordered from our Customer Services team.

Subscriptions

Our range of subscription services are designed to make using standards easier for you. For further information on our subscription products go to bsigroup.com/subscriptions.

With **British Standards Online (BSOL)** you'll have instant access to over 55,000 British and adopted European and international standards from your desktop. It's available 24/7 and is refreshed daily so you'll always be up to date.

You can keep in touch with standards developments and receive substantial discounts on the purchase price of standards, both in single copy and subscription format, by becoming a **BSI Subscribing Member**.

PLUS is an updating service exclusive to BSI Subscribing Members. You will automatically receive the latest hard copy of your standards when they're revised or replaced.

To find out more about becoming a BSI Subscribing Member and the benefits of membership, please visit bsigroup.com/shop.

With a **Multi-User Network Licence (MUNL)** you are able to host standards publications on your intranet. Licences can cover as few or as many users as you wish. With updates supplied as soon as they're available, you can be sure your documentation is current. For further information, email bsmusales@bsigroup.com.

BSI Group Headquarters

389 Chiswick High Road London W4 4AL UK

Revisions

Our British Standards and other publications are updated by amendment or revision.

We continually improve the quality of our products and services to benefit your business. If you find an inaccuracy or ambiguity within a British Standard or other BSI publication please inform the Knowledge Centre.

Copyright

All the data, software and documentation set out in all British Standards and other BSI publications are the property of and copyrighted by BSI, or some person or entity that owns copyright in the information used (such as the international standardization bodies) and has formally licensed such information to BSI for commercial publication and use. Except as permitted under the Copyright, Designs and Patents Act 1988 no extract may be reproduced, stored in a retrieval system or transmitted in any form or by any means – electronic, photocopying, recording or otherwise – without prior written permission from BSI. Details and advice can be obtained from the Copyright & Licensing Department.

Useful Contacts:

Customer Services

Tel: +44 845 086 9001

Email (orders): orders@bsigroup.com

Email (enquiries): cservices@bsigroup.com

Subscriptions

Tel: +44 845 086 9001

Email: subscriptions@bsigroup.com

Knowledge Centre

Tel: +44 20 8996 7004

Email: knowledgecentre@bsigroup.com

Copyright & Licensing

Tel: +44 20 8996 7070

Email: copyright@bsigroup.com



...making excellence a habit.™