

BS ISO 11088:2015



BSI Standards Publication

Assembly, adjustment and inspection of an alpine ski/ binding/boot (S-B-B) system

bsi.

...making excellence a habit.™

National foreword

This British Standard is the UK implementation of ISO 11088:2015. It supersedes BS ISO 11088:2006+A1:2012 which is withdrawn.

The UK participation in its preparation was entrusted to Technical Committee SW/136, Sports, playground and other recreational equipment.

A list of organizations represented on this committee can be obtained on request to its secretary.

This publication does not purport to include all the necessary provisions of a contract. Users are responsible for its correct application.

© The British Standards Institution 2015.
Published by BSI Standards Limited 2015

ISBN 978 0 580 89765 8

ICS 97.220.20

Compliance with a British Standard cannot confer immunity from legal obligations.

This British Standard was published under the authority of the Standards Policy and Strategy Committee on 31 December 2015.

Amendments/corrigenda issued since publication

Date	Text affected
------	---------------

INTERNATIONAL
STANDARD

ISO
11088

Fifth edition
2015-12-15

**Assembly, adjustment and inspection
of an alpine ski/binding/boot
(S-B-B) system**

*Montage, réglage et contrôle d'un ensemble ski/fixation/chaussure
(SFC) pour skis alpins*



Reference number
ISO 11088:2015(E)



COPYRIGHT PROTECTED DOCUMENT

© ISO 2015, Published in Switzerland

All rights reserved. Unless otherwise specified, no part of this publication may be reproduced or utilized otherwise in any form or by any means, electronic or mechanical, including photocopying, or posting on the internet or an intranet, without prior written permission. Permission can be requested from either ISO at the address below or ISO's member body in the country of the requester.

ISO copyright office
Ch. de Blandonnet 8 • CP 401
CH-1214 Vernier, Geneva, Switzerland
Tel. +41 22 749 01 11
Fax +41 22 749 09 47
copyright@iso.org
www.iso.org

Contents

Page

Foreword	iv
Introduction	v
1 Scope	1
2 Normative references	1
3 Terms and definitions	1
4 Skier's parameters	3
4.1 General.....	3
4.2 Weight method.....	3
5 Equipment parameters	3
5.1 Choice of new equipment.....	3
5.2 Visual inspection and preparation of used equipment.....	3
5.3 Assembly.....	4
5.4 Binding-to-boot fitting adjustments.....	4
5.5 Initial indicator adjustment.....	4
5.6 Functional check (inspection of functions).....	4
5.7 Measurement of release moment.....	4
5.8 Report.....	5
Annex A (normative) Definition of skier type	6
Annex B (normative) Method of setting	8
Annex C (normative) Flow chart	10
Annex D (normative) Clean versus lubricated diagnostic test for boot/binding compatibility	11
Annex E (normative) Drill	12
Bibliography	13

Foreword

ISO (the International Organization for Standardization) is a worldwide federation of national standards bodies (ISO member bodies). The work of preparing International Standards is normally carried out through ISO technical committees. Each member body interested in a subject for which a technical committee has been established has the right to be represented on that committee. International organizations, governmental and non-governmental, in liaison with ISO, also take part in the work. ISO collaborates closely with the International Electrotechnical Commission (IEC) on all matters of electrotechnical standardization.

The procedures used to develop this document and those intended for its further maintenance are described in the ISO/IEC Directives, Part 1. In particular the different approval criteria needed for the different types of ISO documents should be noted. This document was drafted in accordance with the editorial rules of the ISO/IEC Directives, Part 2 (see www.iso.org/directives).

Attention is drawn to the possibility that some of the elements of this document may be the subject of patent rights. ISO shall not be held responsible for identifying any or all such patent rights. Details of any patent rights identified during the development of the document will be in the Introduction and/or on the ISO list of patent declarations received (see www.iso.org/patents).

Any trade name used in this document is information given for the convenience of users and does not constitute an endorsement.

For an explanation on the meaning of ISO specific terms and expressions related to conformity assessment, as well as information about ISO's adherence to the WTO principles in the Technical Barriers to Trade (TBT) see the following URL: [Foreword - Supplementary information](#)

The committee responsible for this document is ISO/TC 83, *Sports and other recreational facilities and equipment*, Subcommittee SC 4, *Snowsports equipment*.

This fifth edition cancels and replaces the fourth edition (ISO 11088:2006), which has been technically revised where Annex F (informative) has been removed.

Introduction

International Standards exist for the components of the alpine ski/binding/boot (S-B-B) system, mainly intended for the component manufacturers. An International Standard (ISO 8061) also exists for the selection of release moments. The present International Standard is intended primarily for retailers. However, its aim is to include in one text the different phases of the choice of components, their assembly, adjustment and inspection in the form of practical procedures, and to provide tolerances for inspection and adjustment.

The inspection procedures and tolerances described in this International Standard apply to the condition of the S-B-B system before it leaves the ski shop and are not intended to be used to judge the condition of the equipment once it is put into use.

Assembly, adjustment and inspection of an alpine ski/binding/boot (S-B-B) system

1 Scope

This International Standard specifies assembly, adjustment and inspection procedures for the binding mechanisms of skis, integrating in a practical way, the requirements of those International Standards which are related to skis, bindings and boots.

It is intended for all individuals and institutions concerned with those procedures, and especially for sports retailers.

It is applicable to a ski/binding/boot system (S-B-B) for alpine skiing, of which at least one component is owned by the user.

NOTE In the case where the two components (SB and B) are rented, ISO 13993 gives a method of measurement by sampling as an alternative to systematic measurement, before delivery to the end-user.

2 Normative references

The following documents, in whole or in part, are normatively referenced in this document and are indispensable for its application. For dated references, only the edition cited applies. For undated references, the latest edition of the referenced document (including any amendments) applies.

ISO 5355, *Alpine ski-boots — Requirements and test methods*

ISO 8061:2015, *Alpine ski-bindings — Selection of release torque values*

ISO 8364, *Alpine skis and bindings — Binding mounting area — Requirements and test methods*

ISO 9462, *Alpine ski-bindings — Requirements and test methods*

ISO 9523, *Touring ski-boots for adults — Interface with touring ski-bindings — Requirements and test methods*

ISO 11087, *Alpine ski-bindings — Retention devices — Requirements and test methods*

ISO 11110, *Winter-sports equipment — Test devices for the setting of the functional unit ski/boot/binding — Requirements and tests*

ISO 13992, *Alpine touring ski-bindings — Requirements and test methods*

3 Terms and definitions

For the purposes of this document, the following terms and definitions apply.

3.1

fitting adjustment

procedure required to obtain geometric compatibility and correct functioning of different components

3.2

indicator value

Z-mark

release indicator value marked on the binding in accordance with ISO 9462

3.3 skier type

release adjustment criteria pertaining to the type of skiing to be undertaken, as assessed by the skier in accordance with [Table A.1](#)

Note 1 to entry: The designations L, A, S, which were used in ISO 8061:1984, have been replaced by types 1, 2 and 3, respectively, in ISO 8061:1991 and in ISO 8061:2004.

Note 2 to entry: If the skier desires a setting outside the tolerances of this International Standard, he or she can select such a setting at his or her own discretion. Ski-binding manufacturers should provide guidelines to shops and skiers regarding the recommended magnitude of such changes. Skiers should be clearly informed when these changes result in release values above the upper limit or below the lower limit defined in ISO 8061.

3.4 initial indicator position

release indicator position of the binding corresponding with the instructions given in [Table B.1](#)

3.5 Release moment (values) M_Z and M_Y

3.5.1 selected individual release moment reference moment

(for a given skier) release moment determined in accordance with ISO 8061

3.5.2 measured release moment

(for a given S-B-B system) average or middle quantitative value of three consecutive release measurements in the same direction on the same unit

Note 1 to entry: It is expressed in newton metres.

3.6 deviation accepted for the setting inspection tolerance

maximum difference between the *measured release moment* ([3.5.2](#)) and the *selected individual release moment* ([3.5.1](#))

Note 1 to entry: This difference, which may be reduced by the setting, is limited for M_Z to $\pm 15\%$ or 3 N·m (whichever is greater), and for M_Y to $\pm 15\%$ or 10 N·m (whichever is greater).

3.7 release adjustment

procedure for making the measured M_Z and M_Y values coincide with the selected individual M_Z and M_Y values within the limits stated in [Table B.1](#)

3.8 trouble-shooting procedures

additional procedures recommended by the equipment manufacturer

3.9 deviation accepted for the re-adjustment re-adjustment tolerance

maximum difference between the *measured release moment* ([3.5.2](#)) at the *initial indicator position* ([3.4](#)) and the *selected individual release moment* ([3.5.1](#))

Note 1 to entry: This difference, which may be reduced by re-adjustment, is limited for M_Z to $\pm 30\%$ or 6 N·m (whichever is greater), and for M_Y to $\pm 30\%$ or 10 N·m (whichever is greater).

4 Skier's parameters

4.1 General

The individual release moment values are given in ISO 8061. The following procedure using discrete values may be considered as an acceptable approximation of the basic functions of ISO 8061.

4.2 Weight method

4.2.1 Determine the skier's parameters with the following:

- mass (weight);
- height;
- type (according to [Annex A](#));
- age;
- sole length if necessary.

4.2.2 Using [Table B.1](#), choose the individual release values of M_Z and M_Y .

5 Equipment parameters

5.1 Choice of new equipment

The components shall be in conformance with the following International Standards:

- a) ISO 8364 for skis;
- b) ISO 5355 and ISO 9523 for boots;
- c) ISO 9462 and ISO 13992 for bindings;
- d) ISO 11087 for brakes.

The skier should receive specific recommendations concerning the selection of boot, binding and ski, if they are provided by the manufacturer.

5.2 Visual inspection and preparation of used equipment

If any of the components of the S-B-B system have been used, the installer shall carry out a visual check according to the following criteria. In addition to this, older equipment may require special attention as defined by the manufacturer.

- a) The edges and sole of the ski shall be properly prepared according to the recommendations of the ski manufacturer. Unused mounting holes, if any, shall be carefully filled in, according to the manufacturer's specifications.
- b) The condition of the boot sole shall meet the binding manufacturer's requirements. All buckles, fasteners and support areas shall be in good condition.

In cases where release is independent of the boot (e.g. some plate bindings), the inspection of the sole may be less exacting.

- c) The condition of the binding components shall meet the binding manufacturer's requirements (i.e. no broken, deformed, missing or worn-out parts).

Component guides or rotation points shall be free-moving, free of obvious rust, corrosion and dirt, etc.
The manufacturer's inspection and maintenance instructions shall be observed (including lubrication).
The brake shall not be deformed. Suspect components shall be repaired or exchanged.

5.3 Assembly

When assembling the system, comply with the instructions of the binding and ski manufacturers and use the proper tools.

The use of a drill according to [Annex E](#) is recommended. Once they are drilled, it is recommended that the holes be tapped and glue applied if this is required by the ski manufacturer. New holes shall not be drilled less than 10 mm from old holes (measured from centre of hole to centre of hole), even when they are filled in, unless otherwise specified by the ski or binding manufacturer.

When inserting the screws, take care not to damage the threads. A maximum tightening moment of 4 N·m shall fulfil this requirement, unless otherwise specified by the ski manufacturer.

5.4 Binding-to-boot fitting adjustments

Follow the binding manufacturer's instructions.

5.5 Initial indicator adjustment

The binding manufacturer shall provide a table similar to [Table B.1](#) for his products.

Using [Table B.1](#), adjust the bindings to the appropriate initial indicator position.

5.6 Functional check (inspection of functions)

Check visually that everything conforms to the binding manufacturer's instructions and operates correctly.

Check if the boot returns quickly to its initial position within less than 2 mm after a sideward displacement of approximately 10 mm.

5.7 Measurement of release moment

Precondition the binding by releasing each unit as required by the binding manufacturer.

Using a test device in accordance with ISO 11110, proceed as follows.

- a) Follow the test device manufacturer's instructions and check the calibration of the test device according to the manufacturer's procedures.
- b) Check that the measured $+M_Z$, $-M_Z$ and $+M_Y$ values are within the limits stated in [Table B.1](#) and, if required, correct the release adjustment. If the first two successive release measurements in the same direction fall within the $\pm 15\%$ inspection tolerance range, it is not necessary to make a third release measurement.
- c) If the measured $+M_Z$, $-M_Z$ and $+M_Y$ values fall near opposite limits of the inspection tolerance range, the manufacturer's procedure for evaluation of non-symmetrical release shall be implemented.
- d) If the release values are out of the limit for re-adjustment (see [3.9](#)), check the binding manufacturer's most recent instructions before proceeding. If no instructions are provided, the person mounting the bindings should conduct a clean versus lubricated diagnostic test in accordance with [Annex D](#).
- e) If the measured $+M_Z$, $-M_Z$ and $+M_Y$ values are outside the $\pm 15\%$ inspection tolerance, consult the manufacturer's trouble-shooting instructions. After completing the trouble-shooting procedures,

if the measured values fall within the $\pm 30\%$ limit for re-adjustment tolerance, re-adjustment of the binding may be undertaken. These re-adjustments shall achieve measured values as close as practical to the selected individual release moment, within the $\pm 15\%$ tolerance.

5.8 Report

An adjustment report is established by the ski shop and delivered to the user. It shall contain at least the following information:

- skier's parameters;
- indicator value;
- measured values of M_Z and M_Y , or pass/fail result of the system test.

NOTE The exact content of the report and its delivery conditions are defined by the national standard organizations.

Annex A (normative)

Definition of skier type

NOTE Taken from ISO 8061:2015, Annex A.

A.1 Skier types

A.1.1 It is the responsibility of the skier to determine his or her skier-type classification in accordance with [Table A.1](#)

A.1.2 Skiers are classified by type of skiing into three types, 1, 2 and 3. The definitions are as follows.

- Type 1: cautious skiing on smooth slopes of gentle to moderate pitch. This type also applies to entry level skiers uncertain of their classification. Skiers who designate themselves as type 1 receive lower than average release/retention settings. This corresponds to an increased risk of inadvertent binding release, in order to gain increased capacity for release in the event of a fall.
- Type 2: skiers not classified in type 1 or type 3.
- Type 3: fast, aggressive skiing on slopes of moderate to steep pitch. Skiers who designate themselves as type 3 receive higher than average release/retention settings. This corresponds to decreased capacity for release in the event of a fall, in order to gain a decreased risk of inadvertent binding release.

These designations, 1, 2 and 3, should not be used by the equipment manufacturers to categorize their products.

A.1.3 The information given in [Table A.1](#) is an example of the kind of layout which may be used to assist the skier in determining his or her skier type

Table A.1 — Determination of skier type

Type	1	2	3 ^a
Speed	Slow to moderate	Skiers that do not meet all the descriptions of either 1 or 3	Fast
Terrain	Gentle to moderate		Steep
Style	Cautious (or smooth)		Aggressive
^a Type 3 settings should not be used by skiers of 22 kg or less.			

A.1.4 The information given in [A.1.2](#) can be used to assist the skier in determining the appropriate skier-type classification and to make him aware of the risks related to each classification

A.2 Discretionary settings

A.2.1 Skiers 10 years of age and older of any type who desire a higher or lower setting than the setting of their skier type according to ISO 8061:2015, 4.3.4 a) to d), may designate their preference with a + or – sign next to their skier type designation

A.2.2 The use of these classifications in determining the release setting may be inappropriate for some types of competition skiing

Annex B (normative)

Method of setting

B.1 Locate the skier's weight (mass) and height in the appropriate column. If weight and height are not on the same line, select the line closest to the top of the table

B.2 Consider the skier type (see [Annex A](#)):

- for a type 1 skier, stay on the line and use the reference moment (M_Z and M_Y) on that line;
- for a type 2 skier, move down one line and use the reference moment (M_Z and M_Y) on that line;
- for a type 3 skier, move down two lines and use the reference moment (M_Z and M_Y) on that line.

B.3 Consider the skier's age.

For skiers who are 50 years or older, or under 10 years, move up one line.

B.4 The setting obtained after having considered skier type and age may be lowered or raised in the following cases:

- a) skiers who have satisfactory experience with lower settings regarding the manufacturer's recommendations may request settings based on their experience;
- b) skiers who have skiing experience without inadvertent releases may request a setting up to 15 % lower than that recommended by the manufacturer or one line up in [Table B.1](#);
- c) skiers having certain characteristics like neutral skiing technique, defensive attitude, high degree of control, etc. may request a setting up to 15 % lower than that recommended by the manufacturer or one line up in [Table B.1](#);
- d) skiers who have experienced inadvertent releases may request a setting up to 15 % higher than that recommended by the manufacturer or one line down in [Table B.1](#).

B.5 Skiers may request settings that are different for twist and forward lean.

B.6 Using the boot sole length, determine the initial indicator value.

B.7 The deviation accepted for the setting (inspection tolerance, see [3.6](#)) is equivalent, in [Table B.1](#), to the difference between the value located one line above and the value located one line below the selected individual release moment (reference moment, see [3.5.1](#)).

B.8 The deviation accepted for the re-adjustment (re-adjustment tolerance, see [3.9](#)) is equivalent, in the table, to the difference between the value located 2 lines above and the value located 2 lines below the selected individual release moment (reference moment, see [3.5.1](#)).

Table B.1 — Release value selection using skier's weight

Mandatory release values					Examples for initial indicator valueText ^a							
Skier's parameters			Inspection parameters		Z ^b							
Skier's mass	Skier's height	Skier code	Twist M _Z	Forward lean M _Y	≤230 mm	231 mm to 250 mm	251 mm to 270 mm	271 mm to 290 mm	291 mm to 310 mm	311 mm to 330 mm	331 mm to 350 mm	≥351 mm
kg	m		Nm	Nm	mm	mm	mm	mm	mm	mm	mm	mm
—	—	-	5	18	—	—	—	—	—	—	—	—
10 to 13	—	A	8	29	0,75	0,75	0,75	—	—	—	—	—
14 to 17	—	B	11	40	1,00	0,75	0,75	0,75	—	—	—	—
18 to 21	—	C	14	52	1,50	1,25	1,25	1,0	—	—	—	—
22 to 25	—	D	17	64	2,00	1,75	1,50	1,5	1,25	—	—	—
26 to 30	—	E	20	75	2,50	2,25	2,00	1,75	1,50	1,50	—	—
31 to 35	—	F	23	87	3,00	2,75	2,50	2,25	2,00	1,75	1,75	—
36 to 41	—	G	27	102	—	3,50	3,00	2,75	2,50	2,25	2,00	—
42 to 48	≤1,48	H	31	120	—	—	3,50	3,0	3,00	2,75	2,50	—
49 to 57	1,49 to 1,57	I	37	141	—	—	4,50	4,0	3,50	3,50	3,0	—
58 to 66	1,58 to 1,66	J	43	165	—	—	5,50	5,0	4,50	4,00	3,50	3,00
67 to 78	1,67 to 1,78	K	50	194	—	—	6,50	6,0	5,50	5,00	4,50	4,00
79 to 94	1,79 to 1,94	L	58	229	—	—	7,50	7,0	6,50	6,00	5,50	5,00
≥95	≥1,95	M	67	271	—	—	—	8,50	8,00	7,00	6,50	6,00
—	—	N	78	320	—	—	—	10,00	9,50	8,50	8,00	7,50
—	—	O	91	380	—	—	—	11,50	11,00	10,00	9,50	9,00
—	—	—	105	452	—	—	—	—	—	12,00	11,00	10,50
—	—	—	121	520	—	—	—	—	—	—	—	—
—	—	—	137 ^d	588 ^d	—	—	—	—	—	—	—	—

NOTE 1 For skiers of 13 kg and under, no further correction is appropriate.

NOTE 2 For skiers of 17 kg and under, skier type -1 (see A.2.1) is inappropriate.

^a These are only the starting point in the binding setting process and may need to be modified in order to achieve the correct measured release value.

^b (Pre-setting), depending on boot sole length.

^c Lowermost tolerance limit.

^d Uppermost tolerance limit.

Annex C (normative)

Flow chart

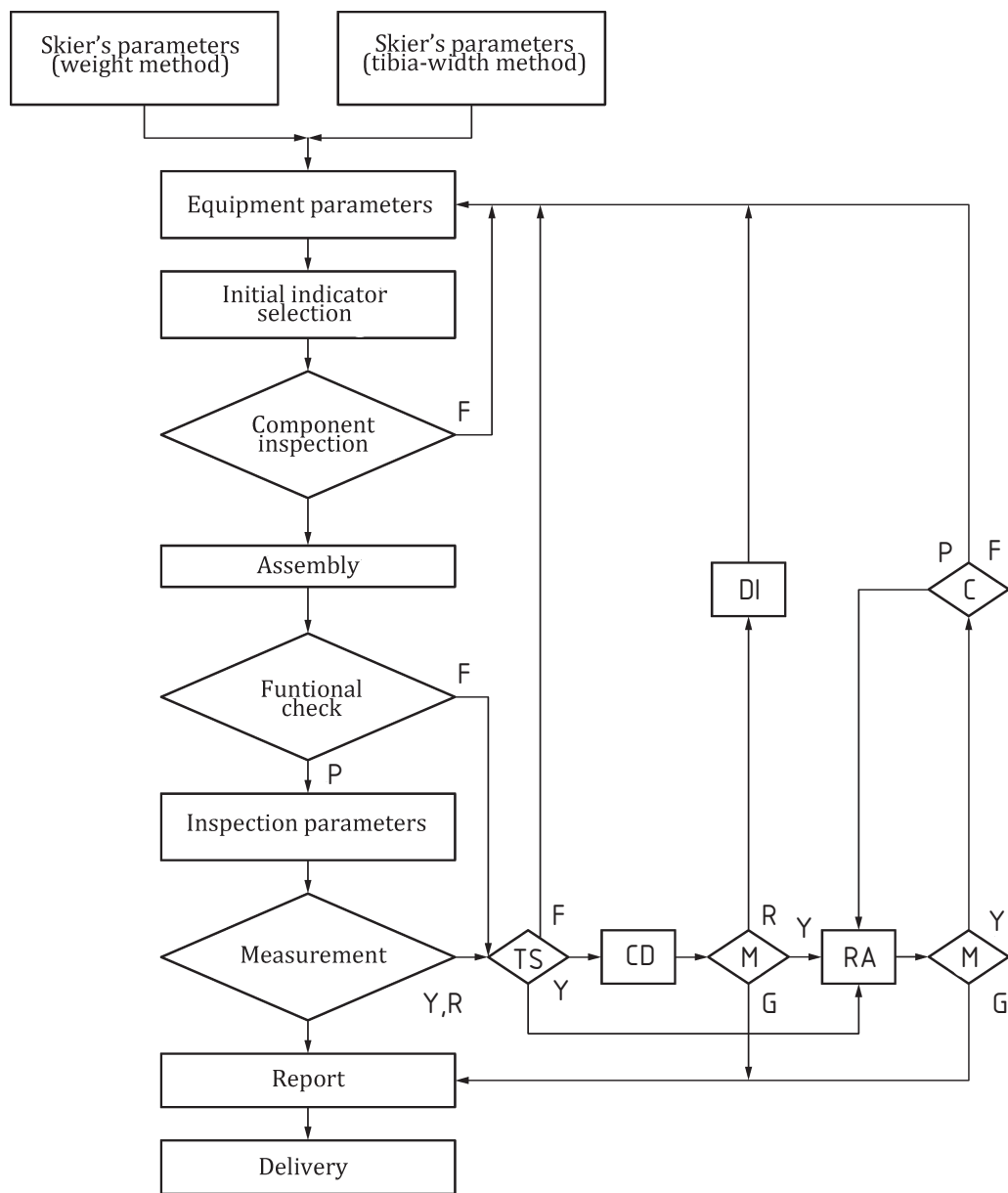

Key

- | | | |
|-------------------|---|--------------------------|
| P pass | G within ±15 % | R greater than ±30 % |
| TS trouble shoot | M remeasure | DI diagnostic inspection |
| F fail | Y greater than ±15 %, not greater than ± 30 % | C check indicator run |
| CD correct defect | RA readjust | |

Figure C.1 — Flow chart

Annex D (normative)

Clean versus lubricated diagnostic test for boot/binding compatibility

Determine the measured release value in the S-B-B system in a clean state, i.e. without lubricant, according to the binding manufacturer's instructions.

Determine the measured release value in the S-B-B system after lubricating all contact points between boot and binding with a lubricant specified by the binding manufacturer, or, if not specified, using a soap and water solution.

Determine the relationship between the values measured in the lubricated and in the clean test by dividing the result in the lubricated test by the clean result in the test.

If the quotient is greater than 1,2 or less than 0,8, the system should be considered incompatible.

Annex E (normative)

Drill

Figure E.1 illustrates a drill which is suitable for drilling holes for screws used for connecting the binding to the ski.

Dimensions in millimetres

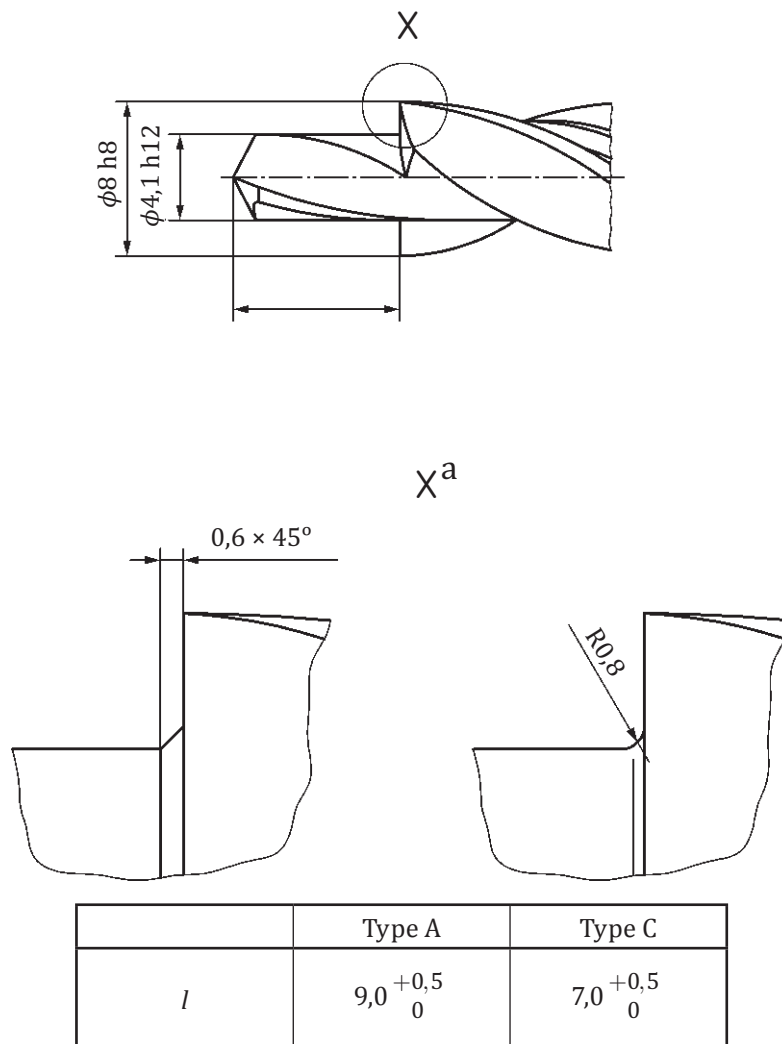

Key

^a Design to be chosen.

Figure E.1 — Drill

Bibliography

- [1] ISO 13993, *Rental ski shop practice — Sampling and inspection of complete and incomplete alpine ski-binding-boot systems in rental applications*

British Standards Institution (BSI)

BSI is the national body responsible for preparing British Standards and other standards-related publications, information and services.

BSI is incorporated by Royal Charter. British Standards and other standardization products are published by BSI Standards Limited.

About us

We bring together business, industry, government, consumers, innovators and others to shape their combined experience and expertise into standards-based solutions.

The knowledge embodied in our standards has been carefully assembled in a dependable format and refined through our open consultation process. Organizations of all sizes and across all sectors choose standards to help them achieve their goals.

Information on standards

We can provide you with the knowledge that your organization needs to succeed. Find out more about British Standards by visiting our website at bsigroup.com/standards or contacting our Customer Services team or Knowledge Centre.

Buying standards

You can buy and download PDF versions of BSI publications, including British and adopted European and international standards, through our website at bsigroup.com/shop, where hard copies can also be purchased.

If you need international and foreign standards from other Standards Development Organizations, hard copies can be ordered from our Customer Services team.

Subscriptions

Our range of subscription services are designed to make using standards easier for you. For further information on our subscription products go to bsigroup.com/subscriptions.

With **British Standards Online (BSOL)** you'll have instant access to over 55,000 British and adopted European and international standards from your desktop. It's available 24/7 and is refreshed daily so you'll always be up to date.

You can keep in touch with standards developments and receive substantial discounts on the purchase price of standards, both in single copy and subscription format, by becoming a **BSI Subscribing Member**.

PLUS is an updating service exclusive to BSI Subscribing Members. You will automatically receive the latest hard copy of your standards when they're revised or replaced.

To find out more about becoming a BSI Subscribing Member and the benefits of membership, please visit bsigroup.com/shop.

With a **Multi-User Network Licence (MUNL)** you are able to host standards publications on your intranet. Licences can cover as few or as many users as you wish. With updates supplied as soon as they're available, you can be sure your documentation is current. For further information, email bsmusales@bsigroup.com.

BSI Group Headquarters

389 Chiswick High Road London W4 4AL UK

Revisions

Our British Standards and other publications are updated by amendment or revision.

We continually improve the quality of our products and services to benefit your business. If you find an inaccuracy or ambiguity within a British Standard or other BSI publication please inform the Knowledge Centre.

Copyright

All the data, software and documentation set out in all British Standards and other BSI publications are the property of and copyrighted by BSI, or some person or entity that owns copyright in the information used (such as the international standardization bodies) and has formally licensed such information to BSI for commercial publication and use. Except as permitted under the Copyright, Designs and Patents Act 1988 no extract may be reproduced, stored in a retrieval system or transmitted in any form or by any means – electronic, photocopying, recording or otherwise – without prior written permission from BSI. Details and advice can be obtained from the Copyright & Licensing Department.

Useful Contacts:

Customer Services

Tel: +44 845 086 9001

Email (orders): orders@bsigroup.com

Email (enquiries): cservices@bsigroup.com

Subscriptions

Tel: +44 845 086 9001

Email: subscriptions@bsigroup.com

Knowledge Centre

Tel: +44 20 8996 7004

Email: knowledgecentre@bsigroup.com

Copyright & Licensing

Tel: +44 20 8996 7070

Email: copyright@bsigroup.com



...making excellence a habit.™