

BS ISO 11037:2011



BSI Standards Publication

# Sensory analysis — Guidelines for sensory assessment of the colour of products

**bsi.**

...making excellence a habit.™

**National foreword**

This British Standard is the UK implementation of ISO 11037:2011. It supersedes BS 5929-10:1999, which is withdrawn.

The UK participation in its preparation was entrusted to Technical Committee AW/12, Sensory analysis.

A list of organizations represented on this committee can be obtained on request to its secretary.

This publication does not purport to include all the necessary provisions of a contract. Users are responsible for its correct application.

© BSI 2011

ISBN 978 0 580 66308 6

ICS 67.240

**Compliance with a British Standard cannot confer immunity from legal obligations.**

This British Standard was published under the authority of the Standards Policy and Strategy Committee on 31 July 2011.

**Amendments issued since publication**

Date	Text affected
------	---------------

---

# INTERNATIONAL STANDARD

BS ISO 11037:2011

**ISO**  
**11037**

Second edition  
2011-07-15

---

---

## **Sensory analysis — Guidelines for sensory assessment of the colour of products**

*Analyse sensorielle — Lignes directrices pour l'évaluation sensorielle  
de la couleur des produits*



Reference number  
ISO 11037:2011(E)

© ISO 2011



**COPYRIGHT PROTECTED DOCUMENT**

© ISO 2011

All rights reserved. Unless otherwise specified, no part of this publication may be reproduced or utilized in any form or by any means, electronic or mechanical, including photocopying and microfilm, without permission in writing from either ISO at the address below or ISO's member body in the country of the requester.

ISO copyright office  
Case postale 56 • CH-1211 Geneva 20  
Tel. + 41 22 749 01 11  
Fax + 41 22 749 09 47  
E-mail [copyright@iso.org](mailto:copyright@iso.org)  
Web [www.iso.org](http://www.iso.org)

Published in Switzerland

## Contents

Page

Foreword .....	iv
Introduction.....	v
1 Scope .....	1
2 Normative references .....	1
3 Terms and definitions .....	2
4 Test conditions .....	4
4.1 General .....	4
4.2 Test room .....	4
4.3 Working area .....	4
4.4 Lighting.....	4
4.5 Illuminance .....	5
4.6 Geometric conditions for illumination and viewing.....	5
4.7 Assessors .....	6
5 Test method .....	7
5.1 Principle.....	7
5.2 Reference materials (colour standards).....	7
5.3 Apparatus .....	7
5.4 Test samples .....	7
5.5 Procedure .....	7
6 Expression of results .....	10
7 Test report.....	11
Annex A (informative) Metameric matches .....	12
Annex B (informative) Viewing arrangements .....	13
Annex C (informative) Complementary information.....	16
Bibliography.....	17

## Foreword

ISO (the International Organization for Standardization) is a worldwide federation of national standards bodies (ISO member bodies). The work of preparing International Standards is normally carried out through ISO technical committees. Each member body interested in a subject for which a technical committee has been established has the right to be represented on that committee. International organizations, governmental and non-governmental, in liaison with ISO, also take part in the work. ISO collaborates closely with the International Electrotechnical Commission (IEC) on all matters of electrotechnical standardization.

International Standards are drafted in accordance with the rules given in the ISO/IEC Directives, Part 2.

The main task of technical committees is to prepare International Standards. Draft International Standards adopted by the technical committees are circulated to the member bodies for voting. Publication as an International Standard requires approval by at least 75 % of the member bodies casting a vote.

Attention is drawn to the possibility that some of the elements of this document may be the subject of patent rights. ISO shall not be held responsible for identifying any or all such patent rights.

ISO 11037 was prepared by Technical Committee ISO/TC 34, *Food products*, Subcommittee SC 12, *Sensory analysis*.

This second edition cancels and replaces the first edition (ISO 11037:1999), which has been technically revised.

## Introduction

For standardized colour comparison, it is necessary to have an assessor with normal colour vision and to have reproducible illumination and viewing conditions. It is usual to match colours to a standard in daylight, but the spectral composition of daylight varies considerably. Although it is difficult to control precisely the spectral distribution of artificial light sources, individual sources are more stable over a limited period than daylight and therefore enable more reproducible colour comparisons to be made.

Unless otherwise agreed, the methods specified in this International Standard use diffuse daylight or an artificial daylight source representative of a phase of daylight with a correlated colour temperature of 6 500 K (CIE standard illuminant D65) for routine comparisons. If there is a dispute, the comparison should always be made under the specified artificial light.

Standards produced by the Commission Internationale de l'Éclairage (CIE) and other documents (see the bibliography) are a primary source of internationally accepted and agreed data for light and lighting, for which international harmonization requires unique definitions. Note that, in documents relating only to visual judgements, the term "observer" is frequently used in place of "assessor".





# Sensory analysis — Guidelines for sensory assessment of the colour of products

## 1 Scope

This International Standard establishes guidelines for the sensory evaluation of the colours of products. The procedures specified are applicable to solid, semi-solid, powder and liquid products, which can be opaque, translucent, cloudy or transparent in nature, as well as matt or glossy.

General information is also given about the viewing and lighting conditions to be used in various situations in sensory analysis, such as difference testing, profile analysis and grading methods, performed by panels of selected assessors or by individual experts in special situations.

This International Standard does not deal with consumer testing or with assessment of the metamerism of colours of food products.

NOTE 1 Metameric matches are described in Annex A.

NOTE 2 Particular products can be subject to specific International Standards for their sensory analysis, e.g. ISO 3591<sup>[1]</sup>, which specifies a wine-tasting glass.

## 2 Normative references

The following referenced documents are indispensable for the application of this document. For dated references, only the edition cited applies. For undated references, the latest edition of the referenced document (including any amendments) applies.

ISO 5492, *Sensory analysis — Vocabulary*

ISO 6658, *Sensory analysis — Methodology — General guidance*

ISO 8586<sup>1)</sup>, *Sensory analysis — General guidance for the selection, training and monitoring of selected and expert assessors*

ISO 8589, *Sensory analysis — General guidance for the design of test rooms*

IEC 60050-845|CIE 17:1987, *International electrotechnical vocabulary — Chapter 845: Lighting|International lighting vocabulary*

---

1) To be published. (Revision of ISO 8586-1:1993 and ISO 8586-2:2008)

### 3 Terms and definitions

For the purposes of this document, the terms and definitions given in ISO 5492 and IEC 60050-845[CIE 17 and the following apply.

#### 3.1

**visual sensory assessor**, noun

**observer**, noun

any person taking part in a sensory evaluation of product colour

NOTE Adapted from ISO 5492:2008, 1.5.

#### 3.2

**hue**

attribute of a visual sensation according to which an area appears to be similar to one of the perceived colours, red, yellow, green and blue, or to a combination of two of them

[IEC 60050-845[CIE 17:1987, 02-35]

#### 3.3

**photopic vision**

vision by the normal eye when it is adapted to levels of luminance of at least several candelas per square metre

NOTE The cones are the principal active photoreceptors in photopic vision.

[IEC 60050-845[CIE 17:1987, 02-09]

#### 3.4

**metameric colour stimuli**

**metamers**

spectrally different colour stimuli that have the same tristimulus values

NOTE The corresponding property is called "metamerism".

[IEC 60050-845[CIE 17:1987, 03-05]

#### 3.5

**colour rendering**

effect of an illuminant on the colour appearance of objects by conscious or subconscious comparison with their colour appearance under a referent illuminant

[IEC 60050-845[CIE 17:1987, 02-59]]

#### 3.6

**colour rendering index**

measure of the degree to which the psychophysical colour of an object illuminated by the test illuminant conforms to that of the same object illuminated by the reference illuminant, suitable allowance having been made for the state of chromatic adaptation

[IEC 60050-845[CIE 17:1987, 02-61]

#### 3.7

**colour matching**

action of making a colour stimulus appear the same in colour as a given colour stimulus

[IEC 60050-845[CIE 17:1987, 03-16]

### 3.8

#### **luminance threshold**

lowest luminance of a stimulus which enables it to be perceived

NOTE The value depends on field size, surround, eye state of adaptation (pupil), and other viewing conditions.

[IEC 60050-845|CIE 17:1987, 02-45]

### 3.9

#### **defective colour vision**

anomaly of vision in which there is a reduced ability to discriminate between some or all colours

[IEC 60050-845|CIE 17:1987, 02-13]

### 3.10

#### **viewing conditions**

conditions under which a visual observation is made, including the angular subtense of the specimen at the eye, the geometric relationship of source, specimen, and eye, the photometric and spectral character of the source, the photometric and spectral character of the field of view surrounding the specimen, and the state of adaptation of the eye

[ASTM E284:2009<sup>[7]</sup>]

### 3.11

#### **chromatic colour**

perceived colour possessing hue

NOTE 1 In everyday speech, the word “colour” is often used in this sense to differentiate from white, grey or black.

NOTE 2 The adjective “coloured” usually refers to chromatic colours.

NOTE 3 Adapted from IEC 60050-845|CIE 17:1987, 02-27.

### 3.12

#### **chromatic adaptation**

change in visual hue after viewing coloured surfaces or lights

### 3.13

#### **adaptation**

process allowing the eye to function in a wide range of illuminance levels by modifying its sensitivity through changes in pupil aperture and photochemical changes in the retina

NOTE Adaptation to darkness takes longer than adaptation to brightness.

### 3.14

#### **daylight illuminant**

illuminant having the same or nearly the same relative spectral power distribution as a phase of daylight

[IEC 60050-845|CIE 17:1987, 03-11]

### 3.15

#### **illuminance (at a point on a surface)**

ratio of the luminous flux incident on an element of surface that contains the point and the area of that element

[IEC 60050-845|CIE 17:1987, 10-100]

## 4 Test conditions

### 4.1 General

General conditions established in ISO 6658 shall be taken into account.

Observations should be performed in a suitable place under strictly controlled conditions of lighting (type, level, direction), and of the surroundings of the viewing area and the geometric conditions (i.e. the relative positions of the light source, sample, and eye). The ideal viewing environment is a viewing box with self-contained illumination designed for colour matching (see Figure B.1). For less exacting colour assessment, or where the facilities available or the nature of the samples make that impracticable, viewing may take place in a booth or in an open space.

### 4.2 Test room

Ensure that the general guidance for the design of test rooms for sensory analysis given in ISO 8589 is complied with.

### 4.3 Working area

All surfaces in and around the working area should be achromatic to avoid colour contrast effects or colour adaptation by the assessor and to avoid influencing the chromatic characteristics of illumination reflected or diffused off it. For most surfaces, a light grey colour with a reflectance not lower than 0,5 is recommended.

The luminance should be moderate and even, with an optimum wall luminance of approximately 100 cd/m<sup>2</sup>.

The luminance of the viewing area should be equal to or slightly higher than that of the surroundings.

The requirements are most important close to the viewing area and can be relaxed for the surroundings, especially if the samples are assessed in a viewing box with self-contained illumination.

The interior of a booth for general use should be painted a matt neutral grey with a luminance factor of about 15 % (e.g. Munsell reference N4 and N5). However, when mainly light colours and near-white colours are to be compared, the interior of the booth may be painted so as to have a luminance factor of 30 % or higher (e.g. Munsell reference N6) in order to give a lower brightness contrast with the colour to be examined.

### 4.4 Lighting

#### 4.4.1 General

Samples that appear identical in colour under one illuminant may appear different under another.

It is recommended that the minimum CIE colour rendering index  $R_a$  of light for colour assessment in sensory laboratories be 90, compared to CIE standard illuminant D65.

For routine colour matching, artificial daylight may be used and exceptionally natural daylight may be used. Because the quality of natural daylight is variable and the assessors' judgements are likely to be affected by surrounding coloured objects, for referee purposes closely controlled artificial illumination in a colour-matching booth shall be used. The assessor shall wear clothing of a neutral colour, and no strongly coloured surfaces, other than the test samples, shall be permitted in the field of view.

#### 4.4.2 Natural daylight illumination

Diffuse daylight, preferably from a partially cloudy north sky in the northern hemisphere and a partially cloudy south sky in the southern hemisphere, and not reflected from any strongly coloured object (e.g. a red brick wall or green tree), shall be used.

Direct sunlight shall be avoided.

#### 4.4.3 Artificial daylight illumination

**4.4.3.1 General.** The artificial sources specified in 4.4.3.2 and 4.4.3.3 shall be used.

**4.4.3.2 Source approximating the CIE standard illuminant D65** (representing average daylight including the ultraviolet region, with a correlated colour temperature of approximately 6 500 K).

NOTE 1 At the time of publication, no source is certified for CIE standard illuminant D65 but “artificial daylight” fluorescent tubes with a colour rendering index higher than 90 are widely used as an approximation to D65.

NOTE 2 The spectral distribution of CIE standard illuminant D65 approximates average natural daylight better than the CIE standard illuminant C.

Practical sources (daylight simulators for colorimetry) shall be used, whose quality of simulation of daylight have been assessed with the method described in CIE 51<sup>[16]</sup>.

The quality of illumination shall conform to the more stringent requirements for category BC (CIELAB) or better.

These sources shall be manufactured to meet the appropriate specification and the manufacturer shall declare the average number of running hours during which the product conforms to the specification.

**4.4.3.3 CIE standard source C** (approximating standard illuminant C, representing partially cloudy sky daylight without ultraviolet component, with a correlated colour temperature of 6 770 K).

This is used only when specifically required, e.g. for colour matching of food samples with a colour atlas.

For further information see Annex C.

#### 4.4.4 Other artificial sources

CIE standard source A is a gas-filled tungsten filament lamp representing Planckian radiation (black body or total radiator) at a correlated colour temperature of about 2 856 K.

It is used only when specifically required, e.g. in evaluating the metamerism of coloured materials (see Annex A).

### 4.5 Illuminance

The illuminance on the sample and on any colour standards used should be between 800 lx and 4 000 lx, a figure towards the upper end of the range being desirable only for dark colours. For comfortable viewing of most colours, illuminance between 1 000 lx and 1 500 lx is desirable.

Glare, either from the light source or other reflecting areas, should not interfere with the assessor's vision.

### 4.6 Geometric conditions for illumination and viewing

#### 4.6.1 Opaque or translucent samples

Changes in illuminant, sample or assessor's eye position can influence the results obtained. For this reason, it is necessary for the geometry to be standardized.

To minimize direct reflection of light from the surface, it is necessary for the angle between the assessor's line of sight and the surface of the sample to differ from the angle at which light from the illuminant strikes the surface.

When a viewing box is used or when samples are viewed in a booth, the usual geometry is for the illuminant to be perpendicular to the surface of the sample and for the assessor's line of sight to be at 45° to the surface.

NOTE This means 0°/45° geometry [see Figure B.2 b)].

When samples are viewed using daylight or are viewed in an open space, it is usual for the illuminant to be at 45° to the surface and for the assessor's line of sight to be perpendicular to the surface [see Figure B.2 a)].

In some cases, the assessor may be permitted or encouraged to move the sample and colour standards to achieve optimal viewing conditions, but if there is any deviation from these recommended standard illumination and viewing conditions (45°, 0°), it is important that the particular conditions used be specified.

#### **4.6.2 Transparent or clear liquids**

See 5.5.2.8.

### **4.7 Assessors**

#### **4.7.1 Recruitment and selection of assessors**

Recruit and select the assessors in accordance with the methods given in ISO 8586.

Assessors for colour assessment shall have normal colour vision. Care is needed because a significant proportion of people have anomalous colour vision. An acceptable level of normality can usually be assured by means of a pseudoisochromatic test (e.g. those in References [21] to [25]), provided that it is used and interpreted strictly in accordance with the instructions. An assessor's ability to discriminate hues can be assessed by a test such as the Farnsworth-Munsell 100-hue test. For selecting critical colour matches, where a high level of performance is required, more sensitive tests (e.g. anomaloscope measurements) are desirable. If an assessor wears glasses to correct vision, these shall have a uniform spectral transmission throughout the visible spectrum, i.e. they may reduce brightness, but shall not be tinted. Since colour vision changes significantly with age, assessors over 40 years of age shall be tested using an anomaloscope or a method whereby the assessor is requested to choose the best match from a metameric series of colours.

No specific recommendations can be made with respect to the panel. Where samples are being inspected for grade specifications, reliance may have to be placed on the judgement of one experienced and highly trained assessor with good colour discrimination ability.

#### **4.7.2 Training**

Assessors should be given practice in comparing, naming, and quantitatively assessing samples of varying hue, lightness and saturation. The ability to discriminate between colours can be expected to improve with training.

#### **4.7.3 Sensory adaptation and fatigue**

The vision of assessors shall be well adapted both to the level of illumination and to the spectral characteristics of the illumination for which the results are valid. If assessors pass from a place with illumination that is very different (e.g. bright sunlight) their vision should be allowed to adapt to the testing environment. Assessors should remain in the adapting illumination until all assessments are completed. However, the quality of visual judgements falls off severely if the assessor works continuously. Therefore, rest periods of several minutes during which no colour matching is attempted shall be taken frequently.

To avoid eye fatigue effects, pastel or complementary colours shall not be viewed immediately after strong colours. When comparing bright saturated colours, if a decision cannot be made rapidly, the assessor shall look away for some seconds at the neutral grey of the surrounding field before attempting a further comparison.

## 5 Test method

### 5.1 Principle

The test sample is compared with colour standards under defined viewing conditions by assessors with normal colour vision.

### 5.2 Reference materials (colour standards)

When visual assessment of a food or a food product is to be made by reference to a standard or a series of standards, these standards may consist of:

- reference materials (colour atlas) selected from some colour classification system [such as the Munsell colour system, natural colour system (NCS), DIN system, NF-AFNOR system];
- reference materials designed to simulate the colour and possibly also the surface appearance of the food;
- selected samples of the food or the food product itself as colour standards.

NOTE At the time of publication, no unified colour atlas and/or system of colour names is accepted internationally.

### 5.3 Apparatus

The characteristics of the equipment used, e.g. colour, gloss or transparency, shall not interfere with colour assessment.

**5.3.1 Containers or dishes**, with coverglasses, for example, for powder samples.

**5.3.2 Holders**, with a rectangular opening in the bottom, for example, for clear liquids.

**5.3.3 Vials, test tubes and flasks, with flat bottoms**, in clear glass, for example, for liquids.

**5.3.4 Small neutral grey screen**, with rectangular opening.

**5.3.5 Large triple aperture grey screen**, with an aperture for the test sample in the centre and apertures for standards on each side.

NOTE The test sample shall be observed through this opening.

### 5.4 Test samples

Apply the general information regarding the conditions for sampling and preparation of samples given in ISO 6658.

### 5.5 Procedure

#### 5.5.1 Preparation of samples

##### 5.5.1.1 Dry powdered samples (particle size less than 1 mm)

Place the test portion, slightly heaped, in a clean container (5.3.1) at least 2 mm deep. Place over this a clear colourless coverglass about 1 mm thick, and press it down with a rotary motion to hold it in place by friction between the container and the coverglass mount.

For very fine powders, the pressure exerted upon the sample by the container becomes critical and may require that a special container be designed. In the measurement of the colours of some powders, for instance,

colour changes many times larger than the allowable tolerances can result from inadvertent pressure on the sample.

#### 5.5.1.2 Opaque solid samples

In general, opaque solids should be presented unaltered or only slightly altered as appropriate (e.g. flattened by pressure, homogenized or prepared so as to have a defined particle size).

#### 5.5.1.3 Opaque liquid samples

Place opaque liquids in a clear glass vial (5.3.3) and assess their colour in the same way as for a solid sample.

### 5.5.2 Evaluation of colour by comparison

#### 5.5.2.1 General

The procedure for comparing a sample with colour standards depends to some extent on the size and surface characteristics of the sample. Methods of handling and viewing the sample depend on whether it is a solid, powder or liquid. However, the principles described in this International Standard apply to all such comparisons.

When testing samples having a glossy or specular (i.e. partially reflective) surface, opaque liquids or powder samples covered with a coverglass, it is necessary to minimize direct reflection of light from the surface. To achieve this, it may be helpful to have a matt black surface opposite the assessor if the sample is viewed at an angle rather than perpendicularly to its surface.

It is important that the illumination of the sample and colour standards be the same both in amount and quality. Even with uniform illumination, it is good practice to interchange them as a check during the comparison.

#### 5.5.2.2 Opaque powder samples

Prepare the sample as specified in 5.5.1.1.

To find the best match between the sample and the colour-matching standards, use the large triple aperture screen (5.3.5), place the standards under the side openings and put the sample under the central opening. The hue, lightness, and saturation of the sample are found by extrapolation or interpolation between the standards.

The small grey screen (5.3.4) may also be used.

#### 5.5.2.3 Opaque solids and flat matt surface samples

Hold the sample in the fingers, or in tweezers if it is small, a short distance above the standards and move it until the best match is found. Care should be taken not to cast a shadow on the standard or the sample. The amount of handling required for comparison, and consequent soiling and wear, of the standards is diminished if the standards are arranged in sequence. If the sample is large and flat, the comparison is facilitated if the small grey screen (5.3.4) with the usual size of rectangular opening is placed over the surface.

NOTE Either rectangular or circular openings can be used.

The samples should be illuminated at an angle of 45° and viewed along the perpendicular to the surface. Since the samples are held above the plane of the colour standards, it is important that the illumination of the two horizontal planes be as near as possible the same in amount and quality. Care should be taken to hold the surface of the sample in the horizontal plane and close to the plane of the standards. Errors in results are possible through inadvertent tilting or raising of the sample surface or through casting shadows on to the sample or the standards. If a source of artificial daylight giving a diffused even illumination over a large area from above is used (illuminating perpendicularly), or if the comparison is made by diffuse light from a large part of the sky, the position of the sample with respect to the light source is less critical.



Samples with matt surfaces are examined as specified above. The recommended angles of illumination and viewing need not be followed as strictly because the appearance of a matt surface does not alter significantly with small variations of these angular conditions.

If colour quality of a food is being assessed visually (rather than being matched to a standard), it is appropriate to make the assessment against the background against which the food is normally displayed or viewed. Such background may be white or coloured rather than grey.

#### **5.5.2.4 Opaque solids with glossy irregular surface**

Particular attention should be given to the specified angles of illumination and viewing. The characteristic colour of the sample is obtained only if specular reflections from the surface are avoided.

#### **5.5.2.5 Opaque solids with glossy regular surface**

In samples of some foods, it is not always possible to prevent light from being reflected back from their glossy surfaces into the eyes of the assessor. Nevertheless, by orienting the sample in its own plane in such a way as to reduce the reflected component to a minimum, the most characteristic colour of the sample is usually obtained.

#### **5.5.2.6 Opaque samples with non-uniform colour**

Some foods, such as roasted coffee beans, may be composed of particles having different individual colours. An overall colour match can be facilitated by rotating a flat container of the food at a rate sufficient to blend the colours into a uniform field. A diffusion screen may be a practical alternative to spinning but care is required to reduce or eliminate scattering of light from the viewed surface of the screen.

#### **5.5.2.7 Opaque, translucent and cloudy liquid samples**

Opaque liquid samples are assessed by holding the liquid in a glass container above the charts as specified for opaque solids (5.5.2.3).

Sometimes translucent or cloudy samples (i.e. samples that both transmit and reflect light) can be assessed by transmitted light, but usually they are more easily assessed by reflected light as for opaque samples. The thickness of the sample can have a significant effect on its colour and shall be specified.

In some cases, colours of translucent samples observed by reflection differ from those observed by transmission so these methods are not equivalent.

#### **5.5.2.8 Clear liquid samples**

Samples to be assessed shall be placed in a transparent holder similar to those used for the measurement of transmittance,  $\tau$ , in analytic chemistry or clinical analysis. This holder shall be made of glass that is non-absorbent in the visible spectrum and have parallel, plane faces with a fixed separation. The thickness of the cells may depend on the optical density [ $A_{10} = \lg(1/\tau)$ ] of the liquid. If  $A_{10}$  is smaller than 1,0 (transmittance greater than 10 %), cells of 10 mm of thickness may be used. If  $A_{10}$  is bigger than 1,0, thicknesses of 5 mm, 2 mm or 1 mm may be used.

For thicknesses of 1 mm and 2 mm, it is essential that parallel plane glasses have a uniform thickness and be parallel within 1 %.

In the case of very transparent samples (such as water, sodas or some refined oils) thicker cells, up to 300 mm or more, may be needed.

The size of the sample (cell) that the assessor observes perpendicularly shall be greater than 10,0 mm  $\times$  10,0 mm. If circular, a diameter of not less than 30 mm is advisable.

Cells may be viewed horizontally [perpendicular to the cell, Figure B.3 a)] or vertically [Figure B.3 b)]. When viewed vertically, cells shall not contain air, since slight tilts in the horizontal plane could then cause differences in depth and consequently in the colour observed.

The preferred arrangement for transparent liquid samples is horizontal viewing of vertical cells [Figure B.3 a)].

For horizontal assessment of vertical liquid samples, it is appropriate to make the observation against a white background illuminated with no less than 1 000 lx. For the purposes of this International Standard, white is a sample with a CIE whiteness index,  $W_{\text{CIE}} > 95$  and a whiteness hue,  $H_w < 1$ , illuminated with CIE standard illuminant D65 at 45° (see IRAM 20022<sup>[19]</sup>).

For horizontal assessment of colour of liquid samples in vertical cells, colour may be assessed visually with the help of the Lovibond system (see ISO 15305).

It is necessary to indicate the visual angle at which the assessor makes the observations. For calculation of  $W_{\text{CIE}}$ , different functions of the corresponding standard assessor of colorimetry (CIE 1931 or CIE 1964) shall be used, according to a visual angle higher or lower than 4°, respectively. To do this, the sample size assessed (e.g. its height) shall be divided by the distance between it and the assessor's eye. If this result is lower than 0,007, the angle is less than 4°; otherwise, it is higher.

If CIE standard illuminant D65 is not available for horizontal observation of vertical liquid cells, CIE standard illuminant C may be used, but  $W_{\text{CIE}}$  and  $H_w$  of the background against which it is assessed shall be calculated for CIE standard illuminant D65.

Table 1 shows the correspondence between terms used to describe surfaces that are almost white (opaque samples) and those for liquids that have little colour (clear samples).

**Table 1 — Colour designations for opaque and clear samples**

Opaque samples	Clear samples
White	Colourless
Pinkish white	Faint pink
Yellowish white	Faint yellow
Greenish white	Faint green
Bluish white	Faint blue
Purplish white	Faint purple

## 6 Expression of results

The colour of a sample may be estimated either by giving the average colour found for the sample or by giving the colour names corresponding to the full range of colour matches obtained. The range of variations in the matches may be in hue, lightness or saturation, or a combination of two or all of these. Colour ranges involving mainly variations in lightness and saturation can often be conveniently indicated by the unmodified name, e.g. orange, brilliant orange, moderate orange, strong orange, vivid orange, and deep orange.

The average colour may be obtained using repeated comparisons by one assessor or by using a panel of assessors, and averaging the results according to the rules of the colour index used.

If standards are used, the report shall specify the colour system used to describe them.

## 7 Test report

The test report shall include at least the following information:

- a) all information necessary for the complete identification of the samples;
- b) the sampling method used, if known;
- c) reference to this International Standard (ISO 11037:2011);
- d) the test parameters and conditions (e.g. light source, colour atlas, system of colour designations, number and characteristics of the assessors);
- e) all operating details not specified in this International Standard, or regarded as optional, together with details of any incidents which may have influenced the test results;
- f) the test results obtained;
- g) the date of the test;
- h) the name of the person supervising the test.

## **Annex A** (informative)

### **Metameric matches**

When two coloured surfaces have identical spectral reflection curves, they match visually under any illuminant irrespective of its spectral characteristics; this is termed a “spectral match”.

It is also possible for two surfaces having different spectral reflection curves to match visually under a given light source, but not to match under another light source with different spectral characteristics; such matches are termed “metameric”.

The simplest method of determining whether a colour match is metameric is to inspect it in the light from a tungsten filament lamp, then under fluorescent lighting. If the match is maintained under both illuminations, it is unlikely to be metameric.

It is possible that a metameric match made under artificial daylight source conforming to this International Standard does not match under certain daylight conditions (e.g. north light from a blue sky or sunlight from a low sun), but matches under the most frequently occurring phases of daylight. When metamerism is present, differences in the colour vision of assessors can influence their assessment as to whether two colours match.

If a numerical description of the metamerism is required, spectral measurements should be made using both CIE standard illuminants D65 and A (tungsten lamp) and the colour difference calculated using the method specified in CIE 15<sup>[15]</sup>.

## Annex B (informative)

### Viewing arrangements

#### B.1 Example of viewing box for colour comparisons

Dimensions in metres

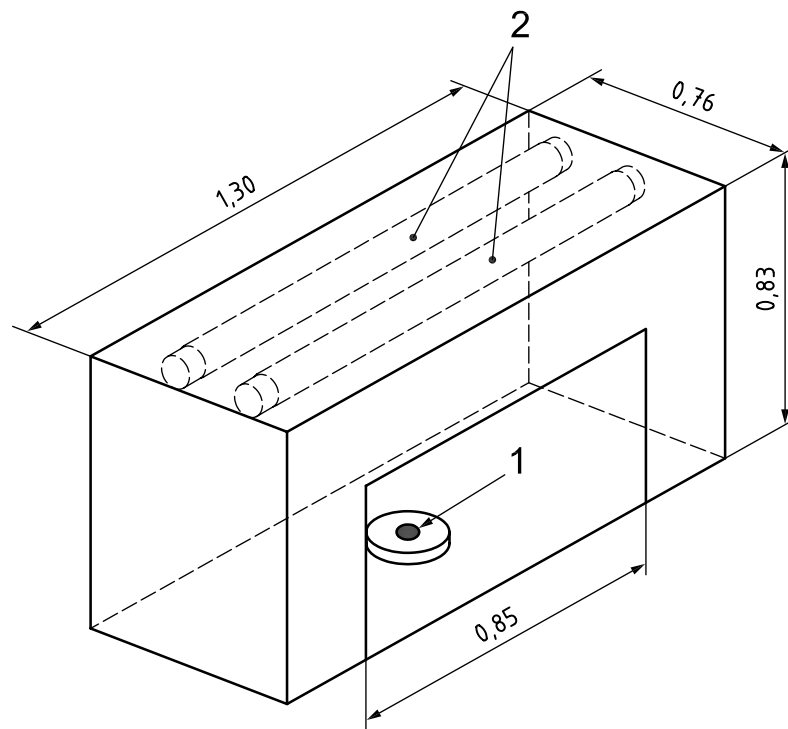

#### Key

- 1 sample
- 2 fluorescent tubes Chroma 75<sup>a</sup> with colour rendering 94 on 7 500 K

<sup>a</sup> Chroma 75 is the trade name of a product supplied by General Electric. This information is given for the convenience of users of this document and does not constitute an endorsement by ISO of the product named. Equivalent products may be used if they can be shown to lead to the same results.

**Figure B.1 — Viewing box for colour comparisons**

## B.2 Relative positions of illuminant, sample and assessor

### B.2.1 45°/0° Geometry

The light impacts on the sample at an angle of 45°. The assessor looks in a position perpendicular to the sample. See Figure B.2 a).

### B.2.2 0°/45° Geometry

The light impacts perpendicularly on the sample. The assessor's eye places on an observation angle of 45°. See Figure B.2 b).

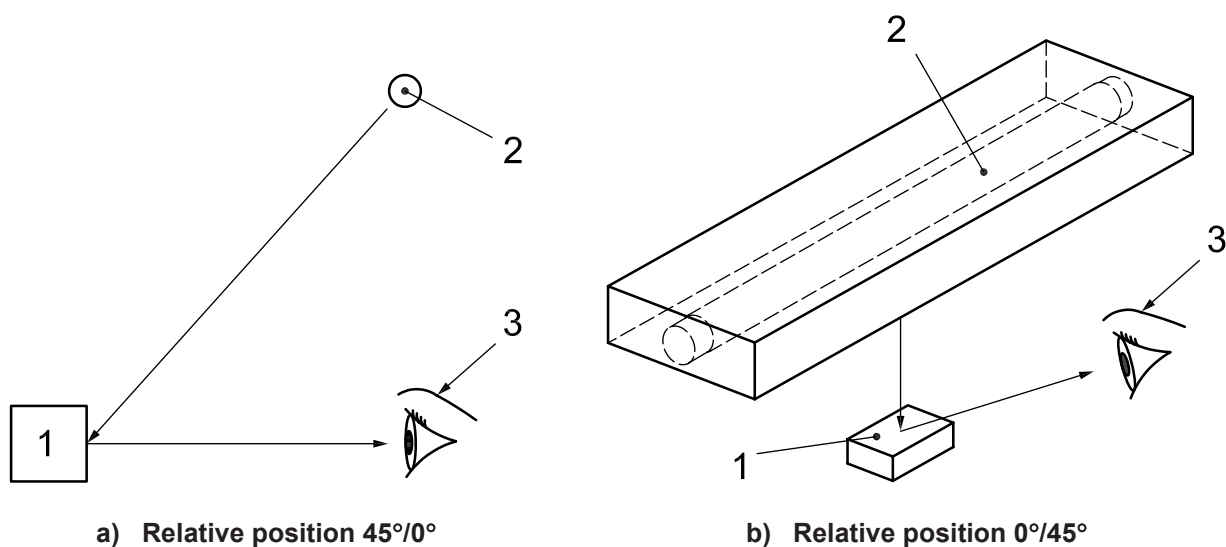

#### Key

- 1 sample
- 2 light source
- 3 assessor

Figure B.2 — Relative positions of illuminant, sample and assessor

### B.3 Relative position of sample, illuminant and assessor

See Figure B.3.

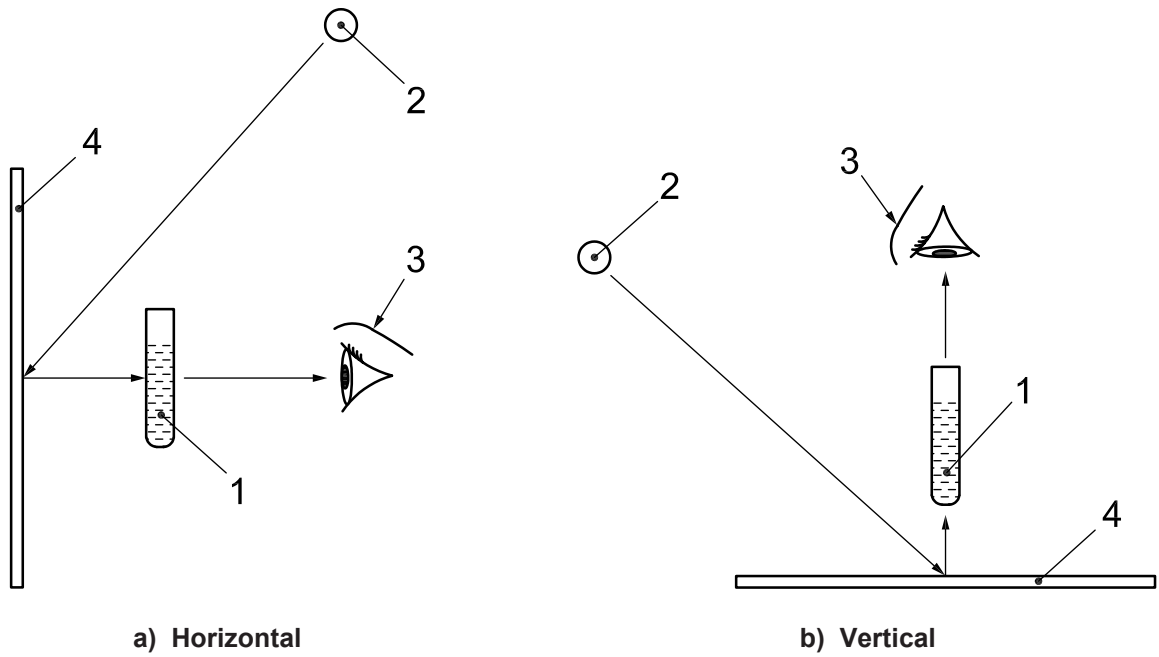

**Key**

- 1 sample
- 2 light source
- 3 assessor
- 4 background

**Figure B.3 — Positions of observation by assessor**

## **Annex C** (informative)

### **Complementary information**

Light is characterized by the spectral distribution of its radiation, the space distribution of the whole radiation and its luminous intensity or the level of illumination on the sample. Not only is the spectrum of the light important, but also how the light impacts on the sample and with what intensity.

The object or the sample reflects or transmits the light in different directions. What is important for the visual appearance of the sample is the light transmitted or reflected in the assessor's direction, therefore it is necessary to specify the way of illuminating the sample, the level of illumination and how the sample shall be observed.

In colour perception, multiple physical, sensory, and psychological factors participate. The same surface or substance can have different colours under different viewing conditions. For that reason, this International Standard specifies light sources, types and levels of illumination and the characteristics of samples and of assessors to try to ensure that discrepancies observed in assessed samples are due, if possible, only to differences between them.

Sunlight is considered "natural", but it is not possible to define it uniquely. It depends on whether the sky is clear, covered or partially covered, and on whether the sample is illuminated with direct solar light, sky light or a mixture of both. Furthermore, the spectrum of solar light varies according to the hour of day and depends on environmental pollution, altitude, geographical latitude and the season of the year.



## Bibliography

- [1] ISO 3591, *Sensory analysis — Apparatus — Wine-tasting glass*
- [2] ISO 3668:1998, *Paints and varnishes — Visual comparison of the colour of paints*
- [3] ISO 11664-1|CIE S 014-1/E:2007, *Colorimetry — Part 1: CIE standard colorimetric observers*
- [4] ISO 11664-2|CIE S 014-2/E:2007, *Colorimetry — Part 2: CIE standard illuminants*
- [5] ISO 15305, *Animal and vegetable fats and oils — Determination of Lovibond colour*
- [6] AS 1680 (all parts), *Interior lighting*
- [7] ASTM E284:2009, *Standard terminology of appearance*
- [8] ASTM E805:2006, *Standard practice for identification of instrumental methods of color or color difference measurement of materials*
- [9] ASTM D1535:2008, *Standard practice for specifying color by the Munsell system*
- [10] ASTM D1729:2009, *Standard practice for visual appraisal of colors and color differences of diffusely illuminated opaque materials*
- [11] ASTM D2616:2003, *Standard test method for evaluation of visual color difference with a gray scale*
- [12] ASTM D4086:2007, *Standard practice for visual evaluation of metamerism*
- [13] BS 950:1967 (all parts), *Artificial daylight for the assessment of colour*
- [14] CIE 13:1995, *Method of measuring and specifying colour rendering properties of light sources*
- [15] CIE 15:2004, *Colorimetry*
- [16] CIE 51:1999, *A method for assessing the quality of daylight simulators for colorimetry*
- [17] DIN 6173-2:1983, *Colour matching — Lighting conditions for average artificial daylight*
- [18] DIN 5033 (all parts), *Farbmessung [Colorimetry]*
- [19] IRAM 20022, *Análisis sensorial — Directivas generales y metodología para la evaluación del color de los alimentos [Sensory analysis — Guidelines and methodology for the evaluation of the color of foods]*
- [20] SS 19102:2004, *NCS atlas (NCS colour atlas)*
- [21] STILLING, J. *Pseudo-isochromatische Tafeln zur Prüfung des Farbsinnes [Pseudoisochromatic colour vision testing plates]*. Leipzig: Thieme, 1909
- [22] VELHAGEN, K. *Tafeln zur Prüfung des Farbsinnes [Colour vision testing plates]*, 33rd edition. Stuttgart: Thieme, 2003, 163 p.
- [23] RJABKIN, E.B. *Polychromatièeskije tablicy dlja issledovanija cvitoošeušèenija*. Moscow: Medgiz, 1954
- [24] *Pseudoisochromatic plate test*. Buffalo, NY: Instrument Division, American Optical Company
- [25] ISHIHARA, S. *Ishihara's tests for colour blindness*. Tokyo: Kanahara, 1994. 38 p.

- [26] MACKINNEY, G., LITTLE, A.C. *Color of foods*. Westport, CT: Avi, 1962. 308 p.
- [27] KELLY, K.L., JUDD, D.B. *Color: Universal language and dictionary of names*. Washington, DC: U.S. Dept. of Commerce, National Bureau of Standards, 1976. 158 p.
- [28] BERGER, A., STROCKA, D. Quantitative assessment of artificial light sources for the best fit to standard illuminant D65. *Appl. Opt.* 1973, **12**, pp. 338-348
- [29] *Manual de Alumbrado Philips*. Madrid: Paraninfo, 1988. 328 p.
- [30] HUTCHINGS, J.B. *Food color and appearance*, 2nd edition. Gaithersburg, MD: Aspen, 1999. 610 p.
- [31] LOZANO, R.D. *El color y su medición* [Colour and its measurement]. Buenos Aires: Americalee, 1978. 640 p.
- [32] FARNSWORTH, D. The Farnsworth-Munsell 100-hue and dichotomous test for color vision. *J. Opt. Soc. Am.* 1943, **33**, pp. 568-578







# British Standards Institution (BSI)

BSI is the national body responsible for preparing British Standards and other standards-related publications, information and services.

BSI is incorporated by Royal Charter. British Standards and other standardization products are published by BSI Standards Limited.

## About us

We bring together business, industry, government, consumers, innovators and others to shape their combined experience and expertise into standards-based solutions.

The knowledge embodied in our standards has been carefully assembled in a dependable format and refined through our open consultation process. Organizations of all sizes and across all sectors choose standards to help them achieve their goals.

## Information on standards

We can provide you with the knowledge that your organization needs to succeed. Find out more about British Standards by visiting our website at [bsigroup.com/standards](http://bsigroup.com/standards) or contacting our Customer Services team or Knowledge Centre.

## Buying standards

You can buy and download PDF versions of BSI publications, including British and adopted European and international standards, through our website at [bsigroup.com/shop](http://bsigroup.com/shop), where hard copies can also be purchased.

If you need international and foreign standards from other Standards Development Organizations, hard copies can be ordered from our Customer Services team.

## Subscriptions

Our range of subscription services are designed to make using standards easier for you. For further information on our subscription products go to [bsigroup.com/subscriptions](http://bsigroup.com/subscriptions).

With **British Standards Online (BSOL)** you'll have instant access to over 55,000 British and adopted European and international standards from your desktop. It's available 24/7 and is refreshed daily so you'll always be up to date.

You can keep in touch with standards developments and receive substantial discounts on the purchase price of standards, both in single copy and subscription format, by becoming a **BSI Subscribing Member**.

**PLUS** is an updating service exclusive to BSI Subscribing Members. You will automatically receive the latest hard copy of your standards when they're revised or replaced.

To find out more about becoming a BSI Subscribing Member and the benefits of membership, please visit [bsigroup.com/shop](http://bsigroup.com/shop).

With a **Multi-User Network Licence (MUNL)** you are able to host standards publications on your intranet. Licences can cover as few or as many users as you wish. With updates supplied as soon as they're available, you can be sure your documentation is current. For further information, email [bsmusales@bsigroup.com](mailto:bsmusales@bsigroup.com).

## BSI Group Headquarters

389 Chiswick High Road London W4 4AL UK

## Revisions

Our British Standards and other publications are updated by amendment or revision.

We continually improve the quality of our products and services to benefit your business. If you find an inaccuracy or ambiguity within a British Standard or other BSI publication please inform the Knowledge Centre.

## Copyright

All the data, software and documentation set out in all British Standards and other BSI publications are the property of and copyrighted by BSI, or some person or entity that owns copyright in the information used (such as the international standardization bodies) and has formally licensed such information to BSI for commercial publication and use. Except as permitted under the Copyright, Designs and Patents Act 1988 no extract may be reproduced, stored in a retrieval system or transmitted in any form or by any means – electronic, photocopying, recording or otherwise – without prior written permission from BSI. Details and advice can be obtained from the Copyright & Licensing Department.

## Useful Contacts:

### Customer Services

**Tel:** +44 845 086 9001

**Email (orders):** [orders@bsigroup.com](mailto:orders@bsigroup.com)

**Email (enquiries):** [cservices@bsigroup.com](mailto:cservices@bsigroup.com)

### Subscriptions

**Tel:** +44 845 086 9001

**Email:** [subscriptions@bsigroup.com](mailto:subscriptions@bsigroup.com)

### Knowledge Centre

**Tel:** +44 20 8996 7004

**Email:** [knowledgecentre@bsigroup.com](mailto:knowledgecentre@bsigroup.com)

### Copyright & Licensing

**Tel:** +44 20 8996 7070

**Email:** [copyright@bsigroup.com](mailto:copyright@bsigroup.com)



...making excellence a habit.™