

Agricultural wheeled tractors and implements — Three- point hitch couplers

Part 3: Link coupler

ICS 65.060.01

National foreword

This British Standard is the UK implementation of ISO 11001-3:2009.

The UK participation in its preparation was entrusted to Technical Committee AGE/6, Agricultural tractors and forestry machinery.

A list of organizations represented on this committee can be obtained on request to its secretary.

This publication does not purport to include all the necessary provisions of a contract. Users are responsible for its correct application.

Compliance with a British Standard cannot confer immunity from legal obligations.

This British Standard was published under the authority of the Standards Policy and Strategy Committee on 28 February 2009

© BSI 2009

ISBN 978 0 580 56217 4

Amendments/corrigenda issued since publication

Date	Comments

**Agricultural wheeled tractors and
implements — Three-point hitch
couplers —**

**Part 3:
Link coupler**

*Tracteurs agricoles à roues et instruments — Coupleurs rapides trois
points —*

Partie 3: Coupleur à rotules



PDF disclaimer

This PDF file may contain embedded typefaces. In accordance with Adobe's licensing policy, this file may be printed or viewed but shall not be edited unless the typefaces which are embedded are licensed to and installed on the computer performing the editing. In downloading this file, parties accept therein the responsibility of not infringing Adobe's licensing policy. The ISO Central Secretariat accepts no liability in this area.

Adobe is a trademark of Adobe Systems Incorporated.

Details of the software products used to create this PDF file can be found in the General Info relative to the file; the PDF-creation parameters were optimized for printing. Every care has been taken to ensure that the file is suitable for use by ISO member bodies. In the unlikely event that a problem relating to it is found, please inform the Central Secretariat at the address given below.



COPYRIGHT PROTECTED DOCUMENT

© ISO 2009

All rights reserved. Unless otherwise specified, no part of this publication may be reproduced or utilized in any form or by any means, electronic or mechanical, including photocopying and microfilm, without permission in writing from either ISO at the address below or ISO's member body in the country of the requester.

ISO copyright office
Case postale 56 • CH-1211 Geneva 20
Tel. + 41 22 749 01 11
Fax + 41 22 749 09 47
E-mail copyright@iso.org
Web www.iso.org

Published in Switzerland

Foreword

ISO (the International Organization for Standardization) is a worldwide federation of national standards bodies (ISO member bodies). The work of preparing International Standards is normally carried out through ISO technical committees. Each member body interested in a subject for which a technical committee has been established has the right to be represented on that committee. International organizations, governmental and non-governmental, in liaison with ISO, also take part in the work. ISO collaborates closely with the International Electrotechnical Commission (IEC) on all matters of electrotechnical standardization.

International Standards are drafted in accordance with the rules given in the ISO/IEC Directives, Part 2.

The main task of technical committees is to prepare International Standards. Draft International Standards adopted by the technical committees are circulated to the member bodies for voting. Publication as an International Standard requires approval by at least 75 % of the member bodies casting a vote.

Attention is drawn to the possibility that some of the elements of this document may be the subject of patent rights. ISO shall not be held responsible for identifying any or all such patent rights.

ISO 11001-3 was prepared by Technical Committee ISO/TC 23, *Tractors and machinery for agriculture and forestry*, Subcommittee SC 4, *Tractors*.

This second edition cancels and replaces the first edition (ISO 11001-3:1993), which has been technically revised.

ISO 11001 consists of the following parts, under the general title *Agricultural wheeled tractors and implements — Three-point hitch couplers*:

- *Part 1: U-frame coupler*
- *Part 2: A-frame coupler*
- *Part 3: Link coupler*
- *Part 4: Bar coupler*

Agricultural wheeled tractors and implements — Three-point hitch couplers —

Part 3: Link coupler

1 Scope

This part of ISO 11001 specifies the essential dimensions for the attachment of three-point hitch implements to agricultural wheeled tractors equipped with a three-point linkage according to ISO 730 or ISO 8759-1 and a link coupler.

2 Normative references

The following referenced documents are indispensable for the application of this document. For dated references, only the edition cited applies. For undated references, the latest edition of the referenced document (including any amendments) applies.

ISO 286-2:1988, *ISO system of limits and fits — Part 2: Tables of standard tolerance grades and limit deviations for holes and shafts*

ISO 730:2009, *Agricultural wheeled tractors — Rear-mounted three-point linkage — Categories 1N, 1, 2N, 2, 3N, 3, 4N and 4*

ISO 2332:2009, *Agricultural tractors and machinery — Connection of implements via three-point linkage — Clearance zone around implement*

ISO 8759-1:1998, *Agricultural wheeled tractors — Front-mounted equipment — Part 1: Power take-off and three-point linkage*

3 Link coupler

3.1 Principle of link coupler

The three-point hitch coupler system constitutes a special method of implement mounting. A hitch coupler is an additional component located between the three-point linkage and the implement making it possible to hitch and unhitch from the operator's seat.

A link coupler system is a two-phase implement coupler where the three-point linkage of the tractor is fitted with devices (e.g. hooks) able to connect to an implement provided with two balls on the lower hitch attachments and one ball on the upper hitch attachment. Hitching and unhitching can be operated from the tractor operator's seat.

In general, the dimensions associated with the tractors and the implement for use with hitch couplers are the same as those for the three-point linkage specified in ISO 730 or ISO 8759-1 and those for the clearance zone specified in ISO 2332.

3.2 Locking device

A positive latch shall be provided at the upper and lower hitch points to prevent an unintentional separation of the implement.

4 Dimensions and clearance zone

4.1 Dimensions associated with tractor

The dimensions associated with the tractor shall comply with Figure 1 and Table 1. For three-point linkage clearances, see ISO 2332.

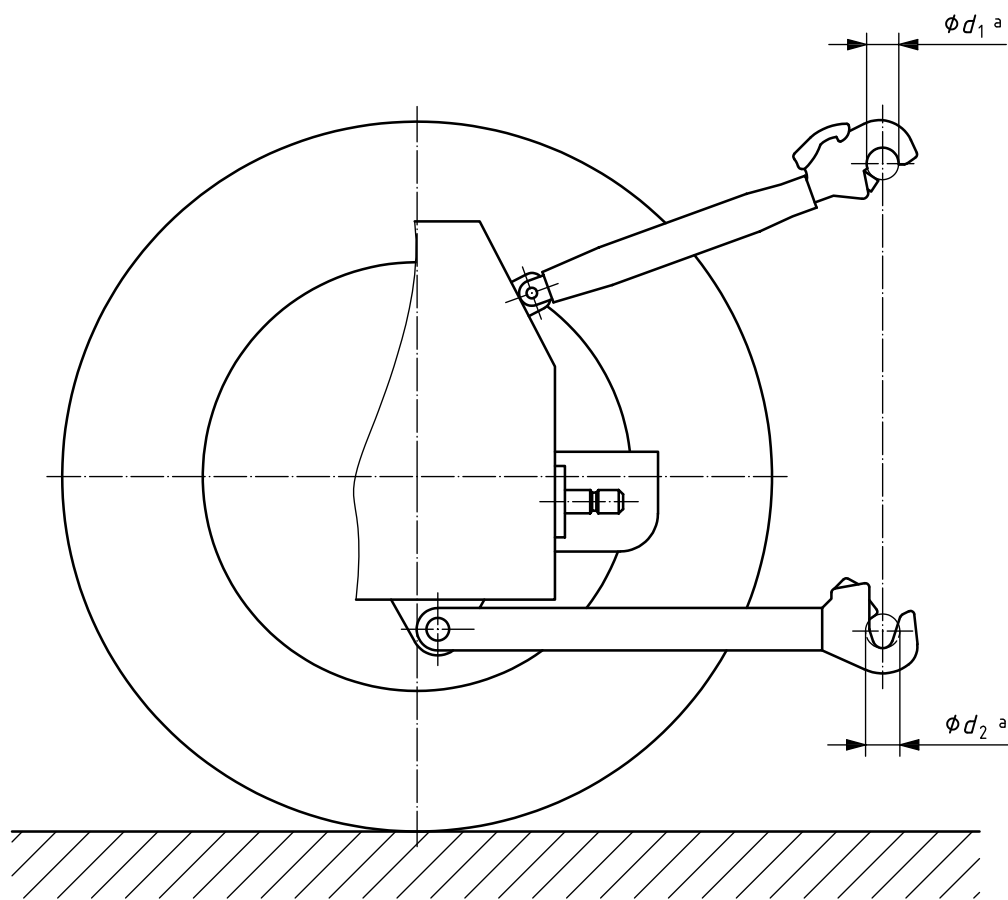

^a Ball.

Figure 1 — Dimensions associated with tractor

Table 1 — Dimensions associated with tractor

Dimensions in millimetres

Category	d_1 A12 ^a	d_2 A12 ^a
1N/1	38	44
2N/2	50	56
3N/3	60	64
4N/4	78	85

^a See ISO 286-2.

4.2 Dimensions associated with implement

The dimensions associated with the implement shall comply with Figure 2 and Table 2. For three-point linkage clearances, see ISO 2332.

Dimensions in millimetres

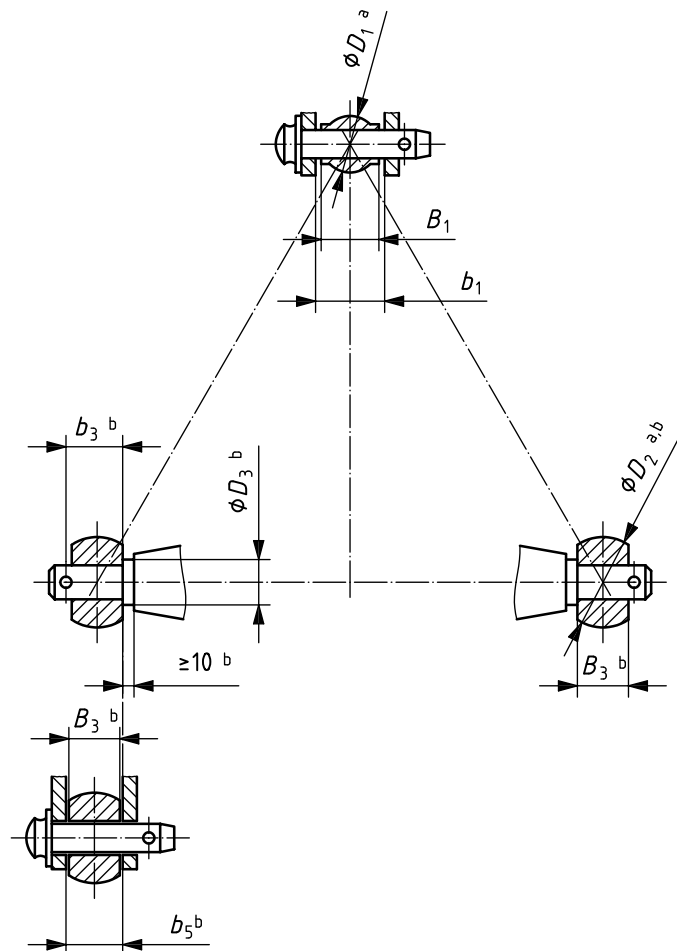

^a Ball.

^b Both sides.

NOTE For dimensions b_1 , b_3 and b_5 , see ISO 730.

Figure 2 — Dimensions associated with implement

Table 2 — Dimensions associated with implement

Dimensions in millimetres

Category	D_1 e11 ^a	D_2 e11 ^a	D_3 ± 1	B_1^b	B_3^b
1N/1	38	44	28	$44_{-0,5}^0$	$35_{-0,5}^0$
2N/2	50	56	35	$51_{-0,5}^0$	$45_{-0,5}^0$
3N/3	60	64	45	$51_{-0,5}^0$	$45_{-0,5}^0$
4N/4	78	85	65	$64_{-0,5}^0$	$57,5_{-0,5}^0$

^a See ISO 286-2.
^b See also ISO 730.

BSI - British Standards Institution

BSI is the independent national body responsible for preparing British Standards. It presents the UK view on standards in Europe and at the international level. It is incorporated by Royal Charter.

Revisions

British Standards are updated by amendment or revision. Users of British Standards should make sure that they possess the latest amendments or editions.

It is the constant aim of BSI to improve the quality of our products and services. We would be grateful if anyone finding an inaccuracy or ambiguity while using this British Standard would inform the Secretary of the technical committee responsible, the identity of which can be found on the inside front cover. Tel: +44 (0)20 8996 9000. Fax: +44 (0)20 8996 7400.

BSI offers members an individual updating service called PLUS which ensures that subscribers automatically receive the latest editions of standards.

Buying standards

Orders for all BSI, international and foreign standards publications should be addressed to Customer Services. Tel: +44 (0)20 8996 9001. Fax: +44 (0)20 8996 7001 Email: orders@bsigroup.com You may also buy directly using a debit/credit card from the BSI Shop on the Website <http://www.bsigroup.com/shop>

In response to orders for international standards, it is BSI policy to supply the BSI implementation of those that have been published as British Standards, unless otherwise requested.

Information on standards

BSI provides a wide range of information on national, European and international standards through its Library and its Technical Help to Exporters Service. Various BSI electronic information services are also available which give details on all its products and services. Contact Information Centre. Tel: +44 (0)20 8996 7111 Fax: +44 (0)20 8996 7048 Email: info@bsigroup.com

Subscribing members of BSI are kept up to date with standards developments and receive substantial discounts on the purchase price of standards. For details of these and other benefits contact Membership Administration. Tel: +44 (0)20 8996 7002 Fax: +44 (0)20 8996 7001 Email: membership@bsigroup.com

Information regarding online access to British Standards via British Standards Online can be found at <http://www.bsigroup.com/BSOL>

Further information about BSI is available on the BSI website at <http://www.bsigroup.com>

Copyright

Copyright subsists in all BSI publications. BSI also holds the copyright, in the UK, of the publications of the international standardization bodies. Except as permitted under the Copyright, Designs and Patents Act 1988 no extract may be reproduced, stored in a retrieval system or transmitted in any form or by any means – electronic, photocopying, recording or otherwise – without prior written permission from BSI.

This does not preclude the free use, in the course of implementing the standard, of necessary details such as symbols, and size, type or grade designations. If these details are to be used for any other purpose than implementation then the prior written permission of BSI must be obtained.

Details and advice can be obtained from the Copyright and Licensing Manager. Tel: +44 (0)20 8996 7070 Email: copyright@bsigroup.com