

BS ISO 10976:2015



BSI Standards Publication

Refrigerated light hydrocarbon fluids — Measurement of cargoes on board LNG carriers

bsi.

...making excellence a habit.™

National foreword

This British Standard is the UK implementation of ISO 10976:2015. It supersedes BS ISO 10976:2012 which is withdrawn.

The UK participation in its preparation was entrusted to Technical Committee PTI/12, Petroleum Measurement and Sampling.

A list of organizations represented on this committee can be obtained on request to its secretary.

This publication does not purport to include all the necessary provisions of a contract. Users are responsible for its correct application.

© The British Standards Institution 2015.
Published by BSI Standards Limited 2015

ISBN 978 0 580 89889 1

ICS 75.180.30

Compliance with a British Standard cannot confer immunity from legal obligations.

This British Standard was published under the authority of the Standards Policy and Strategy Committee on 31 December 2015.

Amendments/corrigenda issued since publication

Date	Text affected
------	---------------

INTERNATIONAL
STANDARD

BS ISO 10976:2015

ISO
10976

Second edition
2015-12-15

**Refrigerated light hydrocarbon
fluids — Measurement of cargoes on
board LNG carriers**

*Hydrocarbures légers réfrigérés — Mesurage des cargaisons à bord
des navires méthaniers*



Reference number
ISO 10976:2015(E)

© ISO 2015



COPYRIGHT PROTECTED DOCUMENT

© ISO 2015, Published in Switzerland

All rights reserved. Unless otherwise specified, no part of this publication may be reproduced or utilized otherwise in any form or by any means, electronic or mechanical, including photocopying, or posting on the internet or an intranet, without prior written permission. Permission can be requested from either ISO at the address below or ISO's member body in the country of the requester.

ISO copyright office
Ch. de Blandonnet 8 • CP 401
CH-1214 Vernier, Geneva, Switzerland
Tel. +41 22 749 01 11
Fax +41 22 749 09 47
copyright@iso.org
www.iso.org

Contents

Page

Foreword	v
Introduction	vi
1 Scope	1
2 Normative references	1
3 Terms, definitions and abbreviated terms	1
3.1 Terms and definitions.....	1
3.2 Abbreviated terms.....	5
4 General operating safety precautions and regulatory requirements	6
4.1 General.....	6
4.2 Electrical equipment classification.....	7
4.3 Electromagnetic disturbance.....	7
4.4 Maintenance.....	7
4.5 Service conditions.....	7
4.6 Compatibility.....	7
4.7 Personnel protection.....	7
4.8 Procedures.....	7
5 Measurement systems and equipment	8
5.1 General.....	8
5.2 Measurement equipment performance.....	8
5.3 Calibration and certification of measurement equipment.....	9
5.4 Verification of measurement equipment between dry dockings.....	9
5.5 Inspection of measurement equipment during transfer operations.....	9
5.6 Static measurement systems and equipment.....	10
5.6.1 General.....	10
5.6.2 Tank capacity tables.....	10
5.6.3 Trim and list measurement.....	12
5.6.4 Tank gassing-up tables or means of determination.....	12
5.6.5 Tank cool-down tables or means of determination.....	13
5.6.6 Liquid level measurement equipment.....	13
5.6.7 Temperature measurement equipment.....	17
5.6.8 Pressure measurement equipment.....	18
5.6.9 Custody transfer measurement system.....	18
5.7 Dynamic measurement systems and equipment.....	19
6 Measurement procedures	19
6.1 General.....	19
6.2 Static measurement.....	20
6.2.1 General.....	20
6.2.2 Measuring liquid level.....	21
6.2.3 Loading.....	21
6.2.4 Discharge.....	21
6.2.5 Shipboard measurements.....	21
6.2.6 Liquid level.....	22
6.2.7 Temperature.....	23
6.2.8 Pressure.....	24
6.2.9 CTMS.....	24
6.2.10 Sampling.....	24
6.2.11 Vapour return.....	25
6.3 Gas-up and cool-down quantification.....	25
6.3.1 General.....	25
6.3.2 Inerting.....	25
6.3.3 Gas up and cool down.....	25
6.4 Dynamic measurement.....	26

7	Cargo calculations	26
7.1	General.....	26
7.2	LNG volume determination.....	26
7.2.1	General.....	26
7.2.2	Liquid levels below lower measurable limit.....	27
7.3	LNG density determination.....	27
	Annex A (informative) LNGC design and marine operations	28
	Annex B (informative) Additional considerations for measurement on board an LNGC	36
	Annex C (informative) Examples of tank capacity tables for a spherical tank	40
	Annex D (informative) Calculation examples	46
	Annex E (informative) Sampling	55
	Annex F (informative) Marine measurement witnessing checklists	59
	Bibliography	62

Foreword

ISO (the International Organization for Standardization) is a worldwide federation of national standards bodies (ISO member bodies). The work of preparing International Standards is normally carried out through ISO technical committees. Each member body interested in a subject for which a technical committee has been established has the right to be represented on that committee. International organizations, governmental and non-governmental, in liaison with ISO, also take part in the work. ISO collaborates closely with the International Electrotechnical Commission (IEC) on all matters of electrotechnical standardization.

The procedures used to develop this document and those intended for its further maintenance are described in the ISO/IEC Directives, Part 1. In particular the different approval criteria needed for the different types of ISO documents should be noted. This document was drafted in accordance with the editorial rules of the ISO/IEC Directives, Part 2 (see www.iso.org/directives).

Attention is drawn to the possibility that some of the elements of this document may be the subject of patent rights. ISO shall not be held responsible for identifying any or all such patent rights. Details of any patent rights identified during the development of the document will be in the Introduction and/or on the ISO list of patent declarations received (see www.iso.org/patents).

Any trade name used in this document is information given for the convenience of users and does not constitute an endorsement.

For an explanation on the meaning of ISO specific terms and expressions related to conformity assessment, as well as information about ISO's adherence to the WTO principles in the Technical Barriers to Trade (TBT) see the following URL: [Foreword - Supplementary information](#)

The committee responsible for this document is ISO/TC 28, *Petroleum products and lubricants*, Subcommittee SC 5, *Measurement of refrigerated hydrocarbon and non-petroleum based liquefied gaseous fuels*.

This second edition cancels and replaces the first edition (ISO 10976:2012), of which it constitutes a minor revision.

Introduction

This International Standard provides accepted methods for measuring quantities on liquefied natural gas (LNG) carriers for those involved in the LNG trade on ships and onshore. It includes recommended methods for measuring, reporting and documenting quantities on board these vessels.

This International Standard is intended to establish uniform practices for the measurement of the quantity of cargo on board LNG carriers from which the energy is computed. It details the commonly used current methods of cargo measurement, but is not intended to preclude the use or development of any other technologies or methods or the revision of the methods presented. It is intended that the reader review, in detail, the latest editions of the publications, standards and documents referenced in this International Standard in order to gain a better understanding of the methods described.

This International Standard is not intended to supersede any safety or operating practices recommended by organizations, such as the International Maritime Organization (IMO), the International Chamber of Shipping (ICS), the Oil Companies International Marine Forum (OCIMF), the International Group of LNG Importers (GIIGNL) and the Society of International Gas Tanker and Terminal Operators (SIGTTO), or individual operating companies. This International Standard is not intended to supersede any other safety or environmental considerations, local regulations or the specific provisions of any contract.

The International System of units (SI) is used throughout this International Standard as the primary units of measure since this system is commonly used in the industry for these types of cargoes. However, as some LNG carrier tanks are calibrated in US customary units and some sales and purchase agreements (SPA) are made in US customary units, both SI and US customary equivalents are shown. Proper unit conversion is intended to be applied, documented and agreed upon among all parties involved in the LNG custody transfer.

Refrigerated light hydrocarbon fluids — Measurement of cargoes on board LNG carriers

1 Scope

This International Standard establishes all of the steps needed to properly measure and account for the quantities of cargoes on liquefied natural gas (LNG) carriers. This includes, but is not limited to, the measurement of liquid volume, vapour volume, temperature and pressure, and accounting for the total quantity of the cargo on board. This International Standard describes the use of common measurement systems used on board LNG carriers, the aim of which is to improve the general knowledge and processes in the measurement of LNG for all parties concerned. This International Standard provides general requirements for those involved in the LNG trade on ships and onshore.

2 Normative references

The following documents, in whole or in part, are normatively referenced in this document and are indispensable for its application. For dated references, only the edition cited applies. For undated references, the latest edition of the referenced document (including any amendments) applies.

ISO 8310, *Refrigerated hydrocarbon and non-petroleum based liquefied gaseous fuels — General requirements for automatic tank thermometers on board marine carriers and floating storage*

ISO 8943, *Refrigerated light hydrocarbon fluids — Sampling of liquefied natural gas — Continuous and intermittent methods*

ISO 18132-1, *Refrigerated hydrocarbon and non-petroleum based liquefied gaseous fuels — General requirements for automatic tank gauges — Part 1: Automatic tank gauges for liquefied natural gas on board marine carriers and floating storage*

IEC 60533, *Electrical and electronic installations in ships — Electromagnetic compatibility*

EN 1160, *Installations and equipment for liquefied natural gas — General characteristics of liquefied natural gas*

IACS, *Unified Requirements E10*

3 Terms, definitions and abbreviated terms

3.1 Terms and definitions

For the purposes of this document, the following terms and definitions apply.

3.1.1

absolute pressure

total of the gauge pressure plus the pressure of the surrounding atmosphere

3.1.2

aerating

<context of preparing a tank for entry> introduction of fresh air with an acceptable dew point into the tank to purge inert gases and to increase the oxygen content to approximately 21 % of volume so as to ensure a breathable atmosphere

3.1.3

approved equipment

equipment of a design approved by a recognized authority, such as a governmental agency, classification society or other accredited agency which certifies the particular equipment as safe for use in a specified hazardous atmosphere

3.1.4

automatic tank gauge

ATG

instrument that automatically measures and displays liquid levels or ullages in one or more tanks, either continuously, periodically or on demand

3.1.5

automatic tank thermometer

ATT

instrument that automatically measures and displays the temperature of the contents in a tank, continuously, periodically or on demand

3.1.6

boil off

process of evaporation of a liquid resulting from heat ingress or a drop in pressure

3.1.7

boil-off gas

vapour produced by boil off

3.1.8

cool down

process of reducing the temperature of equipment, such as piping, transfer arms and tanks associated with custody transfer cargo movements, to required operating temperatures

3.1.9

constant pressure/floating piston sample container

CP/FP sample container

sample container, usually used for intermittent sampling, capable of maintaining constant pressure during the sampling of gas from the process line into the gas cylinder

[SOURCE: ISO 8943:2007, 3.4, modified]

3.1.10

continuous sampling

sampling from gasified LNG with constant flow rate

[SOURCE: ISO 8943:2007, 3.5]

3.1.11

drying

process of reducing the moisture in the ship tank by displacement or dilution with an inert gas or by the use of a drying system

3.1.12

filling limit

filling ratio

quantity to which a tank may be safely filled, taking into account the possible expansion (and change in density) of the liquid

Note 1 to entry: Filling limit (i.e. volume) and filling ratio are expressed as a percentage of the total capacity of a tank.

3.1.13

gas codes

regulations on the construction of ships carrying liquefied gases developed by the International Maritime Organization

Note 1 to entry: These include the IMO *International Code for the Construction and Equipment of Ships Carrying Liquefied Gases in Bulk* (IGC Code) (generally applies to ships built after 17 July 1986), the IMO *Code for Construction and Equipment of Ships Carrying Liquefied Gases in Bulk* (GC Code) (generally applies to ships built on or after 31 December 1976 but prior to 17 July 1986) and the IMO *Code for Existing Ships Carrying Liquefied Gases in Bulk* (generally applies to ships delivered before 31 December 1976), as applicable to each vessel.

3.1.14

gas sample container

sample container, usually used for continuous sampling and used for the retention of the gas sample and for its transfer to an analysing instrument

[SOURCE: ISO 8943:2007, 3.6]

3.1.15

gassing up

process of replacing an inert atmosphere in a cargo tank with the vapour from shore or from another cargo tank to a suitable level to allow cooling down and subsequent loading to achieve a specified environment with at least a defined methane (CH₄), carbon dioxide (CO₂) and oxygen (O₂) content

3.1.16

heel

amount of cargo retained in a cargo tank prior to loading or after discharge

3.1.17

inerting

introduction of inert gas into a tank with the object of attaining the inert condition

3.1.18

intermittent sampling

sampling from gasified LNG with predetermined intervals or with predetermined flow amount intervals

[SOURCE: ISO 8943:2007, 3.9]

3.1.19

letter of protest

letter issued by any participant in a custody transfer citing any condition with which issue is taken and which serves as a written record that a particular action or finding was observed/questioned at the time of occurrence

3.1.20

LNG carrier

cargo ship specifically constructed and used for the carriage of LNG in bulk

3.1.21

LNG sample vaporizer

apparatus to completely gasify the LNG sample collected from the LNG transfer line

[SOURCE: ISO 8943:2007, 3.11]

3.1.22
multiple-spot ATT
multiple-point ATT

ATT consisting of multiple spot temperature element sensors to measure the temperature(s) at selected liquid level(s)

[SOURCE: ISO 4266-5:2002, 3.4, modified]

Note 1 to entry: The readout equipment for a multiple-point averaging ATT averages the readings from the submerged temperature elements sensors to compute the average temperature of the liquid in the tank, and can also display the temperature profile in the tank.

3.1.23
notice of apparent discrepancy

notice issued by any participant in a custody transfer citing any discrepancy in cargo quantities and which serves as a written record that such a discrepancy was found

3.1.24
offline analysis

procedure of analysis implemented on the representative sample gas that is once charged into a gas sample container or a CP/FP sample container

[SOURCE: ISO 8943:2007, 3.13]

3.1.25
online analysis

procedure of analysis implemented using analytical equipment that is directly connected through pipelines or other means to the sampling device

[SOURCE: ISO 8943:2007, 3.14, modified]

3.1.26
online gas chromatograph

gas chromatograph that is directly connected to the pipelines or sampling device to implement online analysis

[SOURCE: ISO 8943:2007, 3.15]

3.1.27
seal water

water used in the water seal type gas sample holder to preclude contact of the gas sample with the atmosphere

[SOURCE: ISO 8943:2007, 3.19]

3.1.28
tank capacity table

numeric tables that relate the liquid level in a tank to the volume contained in that tank

3.1.29
vapour

fluid in the gaseous state that is transferred to/from or contained within the cargo tank

3.1.30
vapour pressure

pressure at which a liquid and its vapour are in equilibrium at a given temperature

3.1.31
verification

process of confirming the accuracy of an instrument by comparing to a source with known accuracy

3.1.32

warming up

process of warming the cargo tanks from cargo carriage temperature to required temperature

3.1.33

waterless-type gas sample holder

holder without seal water (typically using an expandable/contractible, transformable rubber membrane) and used for collecting gasified LNG

[SOURCE: ISO 8943:2007, 3.22]

3.1.34

water-seal-type gas sample holder

holder with seal water used for collecting gasified LNG

[SOURCE: ISO 8943:2007, 3.23]

3.2 Abbreviated terms

API	American Petroleum Institute
ATG	Automatic tank gauge
ATT	Automatic tank thermometer
BOG	Boil-off gas
CTMS	Custody transfer measurement system
EMC	Electromagnetic compatibility
FSRU	Floating storage and re-gasification unit
GCU	Gas combustion unit
GIIGNL	Groupe International des Importateurs de Gaz Naturel Liquéfié
GNG	Gaseous natural gas
GPA	Gas Processors Association
IACS	International Association of Classification Societies
IAPH	International Association of Ports and Harbors
ICS	International Chamber of Shipping
IEC	International Electrotechnical Commission
IGC Code	International Gas Carrier Code
IMO	International Maritime Organization
ISGOTT	International Safety Guide for Oil Tankers and Terminals
ISO	International Organization for Standardization
LNG	Liquefied natural gas
LNGC	Liquefied natural gas carrier
MPMS	Manual of Petroleum Measurement Standards

MSDS	Material safety data sheet
OBQ	On board quantity
OCIMF	Oil Companies International Marine Forum
ROB	Quantity remaining on board
SI	International System of Units (Système International d'Unités)
SIGTTO	Society of International Gas Tanker and Terminal Operators Limited
SPA	Sales and purchase agreement
VEF	Vessel experience factor

4 General operating safety precautions and regulatory requirements

4.1 General

This Clause applies to all types of measurement on board LNG carriers. However, while these precautions represent safe operating practices, they should not be considered complete or comprehensive. In addition to those listed in this International Standard, reference should be made to all safety precautions contained in any relevant governmental, local or company operating guidelines.

IMPORTANT — Anyone working with the vessel's measurement equipment shall be, at all times, under the direction and supervision of the Master of the vessel or its designated representative and be properly trained in its use.

Personnel involved in the handling of liquefied natural gas should be familiar with its physical and chemical characteristics, including potential for fire, explosion, cryogenic burns (frostbite) and reactivity, as well as the appropriate emergency procedures. These procedures should comply with the individual company's safe operating practices, in addition to local, state and federal regulations, including those covering the use of proper protective clothing and equipment. Personnel should be alert in order to avoid potential sources of ignition.

SIGTTO publications *Liquefied Gas Fire Hazard Management* and *Liquefied Gas Handling Principles on Ships and in Terminals* should be consulted to ensure familiarity with the characteristics and hazards of LNG, all fire protection and firefighting equipment on board LNG carriers along with the appropriate fire hazard management plan.

API Standard 2217A and any applicable regulations should be consulted where entering into confined spaces.

Information regarding particular material safety and conditions should be obtained from the employer, manufacturer or supplier of that material or the material safety data sheet (MSDS).

LNG is carried and handled at extremely low temperatures. The very nature of liquids at very low temperatures is a hazard, added to which LNG itself has properties that shall be taken into account at all times. Any party involved in handling operations shall read and act on information contained within the appropriate MSDS and supporting documents.

Nothing contained in this International Standard is intended to supersede any regulatory requirements or recommended operating practices issued by the vessel's flag administration, classification societies or organizations, such as IMO, SIGTTO or OCIMF, or individual operating companies. This International Standard is not intended to conflict with any safety or environmental considerations, local conditions or the specific provisions of any contract.

Accordingly, the latest editions of relevant IMO, SIGTTO, API and OCIMF publications, and, in particular, the latest editions of the ICS *Tanker Safety Guide — Liquefied Gas*, the OCIMF/ICS/IAPH *International*

Safety Guide for Oil Tankers and Terminals (ISGOTT) and *SIGTTO Liquefied Gas Fire Hazard Management* should be consulted for applicable safety precautions.

Any changes to measurement systems require the approval of the vessel's flag administration and/or classification society and require external verification of accuracy by a competent metrological authority for LNG custody transfer measurement purposes.

All described equipment shall meet minimum requirements as detailed by the vessel's flag administration and classification society.

4.2 Electrical equipment classification

All measurement equipment used shall be approved equipment (see [3.1.3](#)), which is certified intrinsically safe or otherwise approved for its intended use, including appropriate grounding. Also, all measurement equipment shall be designed and installed to meet applicable national and international marine safety codes and regulations.

4.3 Electromagnetic disturbance

All custody transfer measurement systems (CTMS) shall be designed for electromagnetic compatibility (EMC), complying with user requirements and other proper standards. This means that the equipment shall neither interfere with nor be affected by interference from other equipment. Requirements and tests shall be in accordance with IACS Unified Requirements E10 and IEC 60533.

4.4 Maintenance

All measurement equipment shall be maintained in safe operating condition and in compliance with the manufacturers' instructions.

4.5 Service conditions

All measurement equipment shall be capable of withstanding the vibration, pressure, temperature, humidity and other environmental operating conditions likely to be encountered in the LNG carrier's service.

4.6 Compatibility

All measurement equipment shall be constructed with appropriate materials suitable for use in LNG service in accordance with the appropriate gas codes (see the note in [3.1.13](#)) or EN 1160, and other applicable regulations.

4.7 Personnel protection

All personnel involved in LNG cargo activities should wear the appropriate personnel protective equipment required for the operation and be trained in its proper use. They should also be trained regarding the inherent hazards of LNG, as required by the *ICS Tanker Safety Guide — Liquefied Gas* and the LNG material safety data sheet (MSDS).

4.8 Procedures

An adequate work procedure shall be established and available as guidance for safe work by the ship and terminal personnel.

5 Measurement systems and equipment

5.1 General

Determination of cargo quantities on board an LNG carrier by the static measurement method requires measurement of the liquid level (which is the liquid/vapour interface) as well as the pressure of the vapour and average liquid and vapour temperature of each cargo tank. The volume of the liquid cargo is calculated using the tank capacity table with any necessary corrections made. The custody transfer measurement system (CTMS) includes the following:

- a) cargo tank capacity tables;
- b) inclinometers and/or draft gauges;
- c) automatic tank gauges (see [3.1.4](#));
- d) multiple-spot ATTs (see [3.1.22](#));
- e) pressure sensors;
- f) a CTMS computer.

NOTE As LNG quantities are generally transferred in units of energy, an automatic sampler system, typically located onshore, provides a representative sample of the cargo, which is analysed for the determination of cargo quality, including density by compositional analysis using a gas chromatograph.

To determine the quantities of cargoes on board LNG carriers, the amount of liquid in each tank shall be determined. The factors needed to accomplish this include a calibrated tank as well as liquid level, pressure, temperature and trim/list measurement equipment. The tank gauging systems used shall be of the closed type. The most commonly used equipment is described in this clause. Certified systems other than those described in this International Standard may be used for custody transfer measurement if the accuracies of each can be ascertained and if the SPA permits their use.

5.2 Measurement equipment performance

The performance criteria of the primary and secondary equipment used to determine measured variables are established in International Standards, governmental regulations, SPAs, manufacturers' instructions and calibration certificates, and are limited by the uncertainty of the instrument. In the absence of specified tolerances, the maximum permissible error from certification shall meet the tolerances described in [Table 1](#).

Table 1 — LNG measurement equipment performance criteria

	Tolerance	Display resolution
Level	±5,0 mm ^a	1 mm
Pressure	±0,3 kPa	0,1 kPa
Temperature		
≤ -145 °C	±0,2 °C	0,1 °C
> -145 °C	±1,5 °C	0,1 °C
Draft reading	±50 mm	10 mm
List (inclinometer)	±0,05°	0,01°
^a Some existing ATGs are not able to meet this verification tolerance, in which case a verification tolerance of ±7,5 mm may be applied.		

5.3 Calibration and certification of measurement equipment

All specified measurement equipment used on board an LNG carrier shall be certified prior to initial use. Subsequently, measurement equipment and systems shall be re-calibrated and re-certified on a periodic basis, subject to SPA or national requirements. Measurement equipment shall be re-certified where modification or repairs are carried out and which affect the accuracy of the measurement data.

The components of the CTMS and the accuracy of the quantity calculation of the CTMS shall be certified by a recognized inspection body.

Calibration and re-calibration shall be performed by a qualified technician and witnessed by an independent inspector. Upon successful calibration, the results shall be certified by the party witnessing the calibration and a certificate of calibration issued.

Manufacturers of the measurement equipment and systems may participate in the calibration, which often require setting, maintenance or replacement prior to final calibration of the equipment and the related measurement system. For measurement equipment and systems, the calibration work should be witnessed by the parties or their appointed independent inspector, who should be responsible for incorporating the results in the certificate issued.

Calibration shall cover the local and remote readout, and data transmission to ensure the equipment, which may consist of components of the measurement subsystem(s), delivers the specified accuracy.

5.4 Verification of measurement equipment between dry dockings

In addition to calibration during each dry docking, all measurement devices used in custody transfer shall be checked before use at each loading or discharge to ensure they are in good working condition.

The comparison of the primary and secondary measurement device within a tank should be performed as one means of verification. The results of this comparison should be recorded and tracked by the vessel operator. One method of evaluating the results is through the use of a control chart. For control charts, see [B.3](#).

Other devices may be verified while the ship is in service. For example, pressure gauges may be verified against a reference standard device. Trim/list gauges, such as inclinometers or draft gauges (if used for level corrections) may be verified/calibrated at even keel by comparison to manual draft measurements or other equivalent procedure.

Where equipment is suspect or has failed, secondary devices shall be used in its place until the equipment is repaired or verified to be in good working order. For example, *in situ* temperature verification/calibration at cryogenic conditions is not practicable; therefore, temperature sensors which have been shown to be faulty when verified during normal operation shall be replaced as soon as practicable.

Where the measurement equipment can be verified against a known value, the results of this verification should be recorded and tracked. If the primary measurement system is found to be out of calibration, use of the secondary measurement system should be considered in accordance with contractual agreement.

5.5 Inspection of measurement equipment during transfer operations

Prior to and during a custody transfer, the involved parties or an appointed independent inspector should inspect the measurement equipment described in [5.1](#) to ensure that it is fully functional, and should also identify any deficiencies. The ship's records should be reviewed to determine whether the calibration certificates are valid and current.

Exceptions and malfunction of measurement equipment, if any, prior to and during a custody transfer should be immediately reported to the LNG carrier operator and the involved parties.

Upon specific request by the involved parties, on board testing, checks or verification may be carried out on the measurement devices in question, and the results should be documented.

5.6 Static measurement systems and equipment

5.6.1 General

Static measurement systems and equipment are those individual systems and equipment which are used to measure cargo in the tank. They include the following components (see [5.6.2](#) to [5.6.9](#)).

5.6.2 Tank capacity tables

5.6.2.1 General

An independent company usually performs the calibration and generates the tank capacity tables during the building of the LNG carrier. They take into account the configuration of the tank, its contraction according to the temperature of the liquid, and the volume occupied by various devices, e.g. cargo pumps.

Tank capacity tables are divided into

- a) main gauge tables correlating liquid level and volume under reference conditions, and
- b) correction tables or methods, taking into account actual conditions of the LNG carrier and its measuring instruments.

The tank capacity tables and related information, including measurements carried out and observations made by the party performing the tank calibration and traceability of the equipment used, may be contained in a tank calibration report. Additional discussion is provided below in [5.6.2.2](#) to [5.6.2.5](#).

Accuracy in determining cargo tank quantities is directly related to the accuracy of the LNG carrier's capacity tables. Therefore, the LNG carrier's cargo tanks shall be measured and tank capacity tables developed and maintained in accordance with API, ISO or other internationally recognized standard or regulatory requirements.

For each LNG carrier, there is a tank capacity table applicable to each custody transfer automatic tank gauging device (ATG) for each tank. For a typical tank equipped with a primary and secondary ATG, this may be presented as two separate capacity tables, each with its own set of correction tables or as a single capacity table based on the primary level device location, with separate correction tables for each ATG and an offset correction for the secondary level device to account for any differences in gauge reference height.

Each set of tank capacity tables and related correction tables or methods shall

- be certified as meeting the standard used,
- state the volumetric uncertainty of the capacity,
- identify the calibration method within the tank capacity tables or in the tank calibration report,
- include examples illustrating their intended use,
- be documented in English, with any additional languages optional, and
- be made available in printed form.

An example of a tank capacity table for a spherical tank is given in [Annex C](#). The same principles generally apply to those vessels with prismatic tanks.

Each set of tables shall include corrections for trim, list, thermal effects and any measurement equipment adjustments as necessary to accurately adjust the quantities observed in the tank to the tank conditions at the time of measurement. In addition, for each tank, the tank capacity tables shall include certified values for any measured level used for verification of the tank gauging system. Tank tables shall indicate the location of the primary and secondary level gauge (i.e. the gauge reference

points). One or more examples shall be included in the tank calibration report or tank capacity table indicating the correct use and interpretation of any correction tables.

Such tables shall be made available to personnel performing the measurements as needed. If such tables are not made available or cannot be verified, a letter of protest noting the situation shall be filed at the time of measurement.

NOTE Tank calibrations reports typically state the tank's volumetric uncertainty at ambient temperature to be $\pm 0,2\%$ or better, which translates to a maximum uncertainty for a tank of 26 000 m³ of ± 52 m³ LNG.

5.6.2.2 Tank capacity tables resolution

Tank capacity tables shall be capable of being read to a resolution of 1 mm throughout the range of levels commonly encountered during opening and closing gauges. In practice, this is usually achieved by tank capacity tables in any one of three formats:

- a) tables showing volumes for each centimetre of gauge height, with volumes for each millimetre corresponding to the normal ranges during opening and closing of gauges (i.e. near the top and bottom of the tank);
- b) tables showing volumes for each centimetre of gauge height with the incremental volume for each row;
- c) tables showing volumes for each millimetre of gauge height throughout the total volume of the tank.

See [Table C.1](#) for an example of a section of a spherical tank capacity table.

5.6.2.3 List and trim correction tables

The main gauge tables are established for an LNG carrier with zero list and trim. Therefore, it is necessary to correct the gauge height reading to take into account a list or a trim which is not zero. This correction differs depending on the position of the gauging device relative to the tank; therefore, unique corrections are required for each different ATG.

These corrections can be positive or negative. So the real height is equal to the algebraic sum of the height reading, the correction for list and the correction for trim. These tables are made up in degrees for the list and in metres for the trim, with fixed steps of variation. For intermediate values, the correction is calculated by interpolation.

See [Table C.2](#) for a sample section of a trim correction table; see [Table C.3](#) for an example of a section of a list correction table.

5.6.2.4 Tank thermal correction tables

Thermal correction tables shall be provided for self-supporting tanks and may be required for other tank designs. The corrections are related to the volume variations resulting from the contraction of the tanks according to the temperature of the liquid and gaseous phases. See [Table C.5](#) for a sample section of a thermal correction table for the tank shell.

5.6.2.5 Level gauging device thermal correction tables

Thermal correction tables may be provided for LNG carriers with level gauging devices of certain types. Such tables attempt to correct the level gauge reading for the effect of temperature, based on the difference between the reference conditions during calibration versus the operating temperature. Corrections may be applied automatically or may have to be applied manually.

For example, the corrections may take into account the shrinkage of the float tape or wire according to the temperature of the gaseous phase and the height of the liquid and the movement of the reference gauge height.

See [Tables C.4](#) and [C.6](#) for examples of sections of thermal correction tables for a radar-type level gauge and float-type level gauge, respectively.

5.6.2.6 Density correction tables

Density correction tables may be provided for float-type level gauges to compensate for the float buoyancy as it varies with LNG density. See [Table C.7](#) for an example.

5.6.3 Trim and list measurement

5.6.3.1 General

Tank capacity tables are based on the ship being on an even keel. Trim and list shall be determined by

- taking the draft fore and aft (either manually or by measurement), and/or
- measuring the list of the LNG carrier.

The impact of trim and list varies with the tank type. On an LNG carrier with spherical tanks, due to the centralized location of the level gauge on the tank, trim and list have a minor impact on the uncertainty of the measured quantities. However, for a membrane tank LNG carrier, the trim correction is affected by the large distance from the tank centre to the typical position of the level gauge near the aft tank bulkhead.

5.6.3.2 Trim and list by inclinometer

Where inclinometers are used in LNG carrier service, they are predominantly two-axis type and are used to measure trim and list, although they may also be used to measure either individually.

Inclinometers measure trim and/or list based on gravitational principles. The most common methods are capacitance based; otherwise, they make use of electrolytic technology, where a liquid in a precisely designed and closed chamber is moving. Other types exist, but only those with servo-assisted technology and an inertial mass/optical sensor within a servo feedback loop give sufficiently accurate and stable measurements. These are electronic instruments which can communicate with the CTMS, preferably using digital signals.

Verification tolerances for inclinometers are provided in [Table 1](#), but it should be noted that this tolerance represents the combined influence of inclinometer uncertainty and the possible contributions from structural bending differences between the inclinometer location and the individual tank locations for the state of load of the LNG carrier.

5.6.3.3 Trim and list by draft measurement

An alternative to inclinometers is draft (alternative spelling: draught) measurement. The draft may be measured manually or automatically, with an electro-pneumatic draft measurement system (with digital communication) being common.

[B.4](#) outlines the process for taking draft readings of the vessel to determine trim and list.

5.6.4 Tank gassing-up tables or means of determination

After lay-up or dry dock, the LNG carrier cargo tanks are filled with nitrogen or other inert gas. If the cargo tanks contain nitrogen, the cool-down process may begin without purging. In order to be in a condition to receive cargo, inert gas may need to be purged with LNG vapour prior to cool down to eliminate high boiling temperature gases, such as carbon dioxide.

LNG carriers usually have gassing-up tables or formulae which are used for determining the quantity of LNG required to gas up the cargo tank(s). These tables give an estimation of the LNG quantity used to gas up the cargo tanks by applying a displacement ratio depending of the type of the cargo tanks (usually between 1,4 and 1,8 for prismatic tanks, and between 1,1 and 1,4 for Moss tanks). Gassing-up tables are

usually provided by the tank manufacturer or shipbuilder and should be certified by the class society or an independent company. Some shore terminals rely on meters as means to measure such quantities.

5.6.5 Tank cool-down tables or means of determination

5.6.5.1 General

LNG carriers have cool-down tables or formulae, which are used for determining the quantity of LNG required to cool a tank down to a specified temperature. Cool-down tables are usually provided by the tank manufacturer or shipbuilder and should be certified by the class society or an independent company. Other methods, such as those employing spray nozzle flow rate and duration or quantities measured by meters, may be used.

5.6.5.2 Cool-down tables

Cool-down tables are based on a specific LNG composition and, therefore, care should be taken to ensure that the composition and heating value therein are appropriate for the cargo to be loaded.

5.6.5.3 Spherical and membrane cargo tanks

The cool-down requirements for a spherical design LNG tanker differ from membrane tank LNG tankers, mostly with respect to the required cool-down temperature.

Spherical tank designs can require that a specific temperature be achieved at the tank equator prior to loading, for example between $-110\text{ }^{\circ}\text{C}$ and $-125\text{ }^{\circ}\text{C}$.

Cool down of membrane tanks may be considered complete once the average of the four lowest sensors reach an appropriate temperature such as $-130\text{ }^{\circ}\text{C}$ or lower.

In addition to the foregoing cool-down requirements, terminal operators may impose other tank cool-down temperature requirements on the vessel prior to commencing loading operations.

See [Table C.8](#) for an example of spherical tank cool-down tables.

5.6.5.4 Cool-down table calculation basis

The following information should be included as part of the tank calibration report or as part of the cool-down table:

- a) cargo tank volume (100 %) including liquid dome;
- b) individual sprayer flow rate;
- c) number of sprayers to be used for cool down;
- d) LNG composition.

5.6.6 Liquid level measurement equipment

5.6.6.1 General

At least two independent means of determining liquid level shall be available for each cargo tank. The primary and secondary level measurement systems shall be independent, such that the failure of one does not affect the other. The systems shall include a provision for an audit trail to record all changes and security to prevent unauthorized changes. The systems installed shall be consistent with the IGC Codes and suitable for the cargoes being carried. See IGC Code, Chapter 19.

The ATG system, also referred to as an automatic level gauging system, shall meet the accuracy, installation, calibration and verification requirements of ISO 18132-1, as well as the requirements of

the vessel's flag administration and classification societies, where applicable. Examples of automatic level measurement technologies applicable to LNG custody transfer include but are not limited to

- a) radar (microwave) gauges,
- b) float gauges, and
- c) capacitance gauges.

Other technologies, such as laser level gauges, are available, but not yet in common usage for LNG custody transfer measurement. Technologies continue to develop and could become more widely used in LNG service in the future. These systems may be used for custody transfer, subject to agreement by all parties involved.

The installation of a new automatic tank gauging system may also require a correction factor to account for a different gauge reference height.

5.6.6.2 Radar (microwave) gauges

The location of the radar level gauge transmitter on the tank is an important consideration. The position of the gauge mounting with respect to the tank's datum point can be subject to the effects of tank shell contraction/expansion due to temperature changes in the tank. Correction for tank shell contraction or expansion should be applied where necessary. Compensation for the effects of trim, list, temperature, pressure and vapour-phase composition shall be applied to observed readings, as appropriate, based on the manufacturer's specifications. For additional details, see [6.2.6.2](#).

A transmitter is mounted on the top of the cargo tank and emits radar waves vertically down towards the surface of the liquid (see [Figure 1](#)). The signal is reflected from the surface, received by the transmitter's antenna and sent back to the control panel. The signal is then processed to determine the distance of the liquid surface from the transmitter and the resultant ullage is converted automatically in the ATG system to innage for display.

5.6.6.3 Float gauges

Float operated level gauges consist of a float attached by a tape or wire to an indicating device which can be arranged for local and remote readout (see [Figure 2](#)). The float may operate in a guide tube or stilling well. Float gauges may have isolation valves fitted such that the float can be maintained, in a safe atmosphere, while the vessel is in service. The float shall be lifted from the liquid level where not in use; if left down, liquid sloshing, while at sea, can damage the tape-tensioning device.

With float gauges, it is necessary to take into account the shrinkage of the tape or wire exposed to and in equilibrium with the temperature of the gaseous phase and the change in buoyancy of the float with respect to the density of the LNG. Compensation for the effects of temperature, trim, list and liquid density shall be applied to the observed readings. For additional details, see [6.2.6.3](#).

5.6.6.4 Capacitance gauges

Capacitance level gauges usually consist of an inner and outer coaxial tube that extends throughout the depth of the cargo tank. The LNG trapped between the two tubes is the dielectric material. The capacitance gauge provides a continuous indication of liquid level based on changes in capacitance as vapour is displaced by LNG (see [Figure 3](#)). The inner tube is supported by the outer tube by means of concentric insulators placed at regularly spaced intervals along the whole length of the tubes. In general, coaxial probes are segmented into 4 m to 5 m lengths to ensure more accurate measurements. These probes are assembled vertically so as to equal the tank height. The resulting assembly forms a series of cylindrical capacitors having the same total height as the cargo tank of the LNG carrier.

The longitudinal contraction of the tubes at low temperature may be taken into account to correct the level measurement. Compensation for the effects of trim and list shall be applied to the observed readings. For additional details, see [6.2.6.4](#).

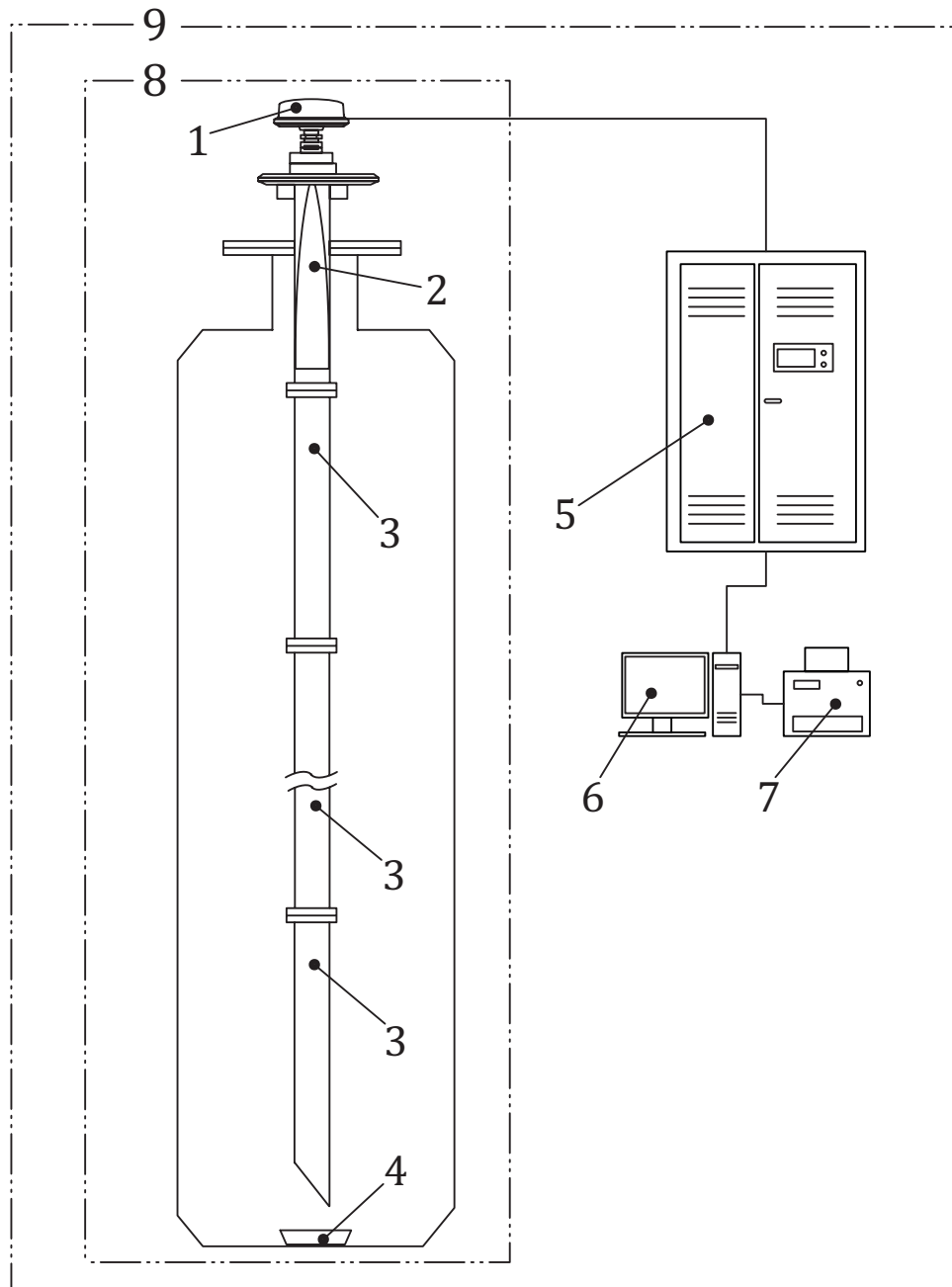

Key

- | | | | |
|---|--------------------------|---|--------------|
| 1 | radar transmitter | 6 | display unit |
| 2 | antenna | 7 | printer |
| 3 | perforated stilling well | 8 | ATG |
| 4 | attenuator | 9 | ATG system |
| 5 | control unit | | |

Figure 1 — Radar (microwave) gauge

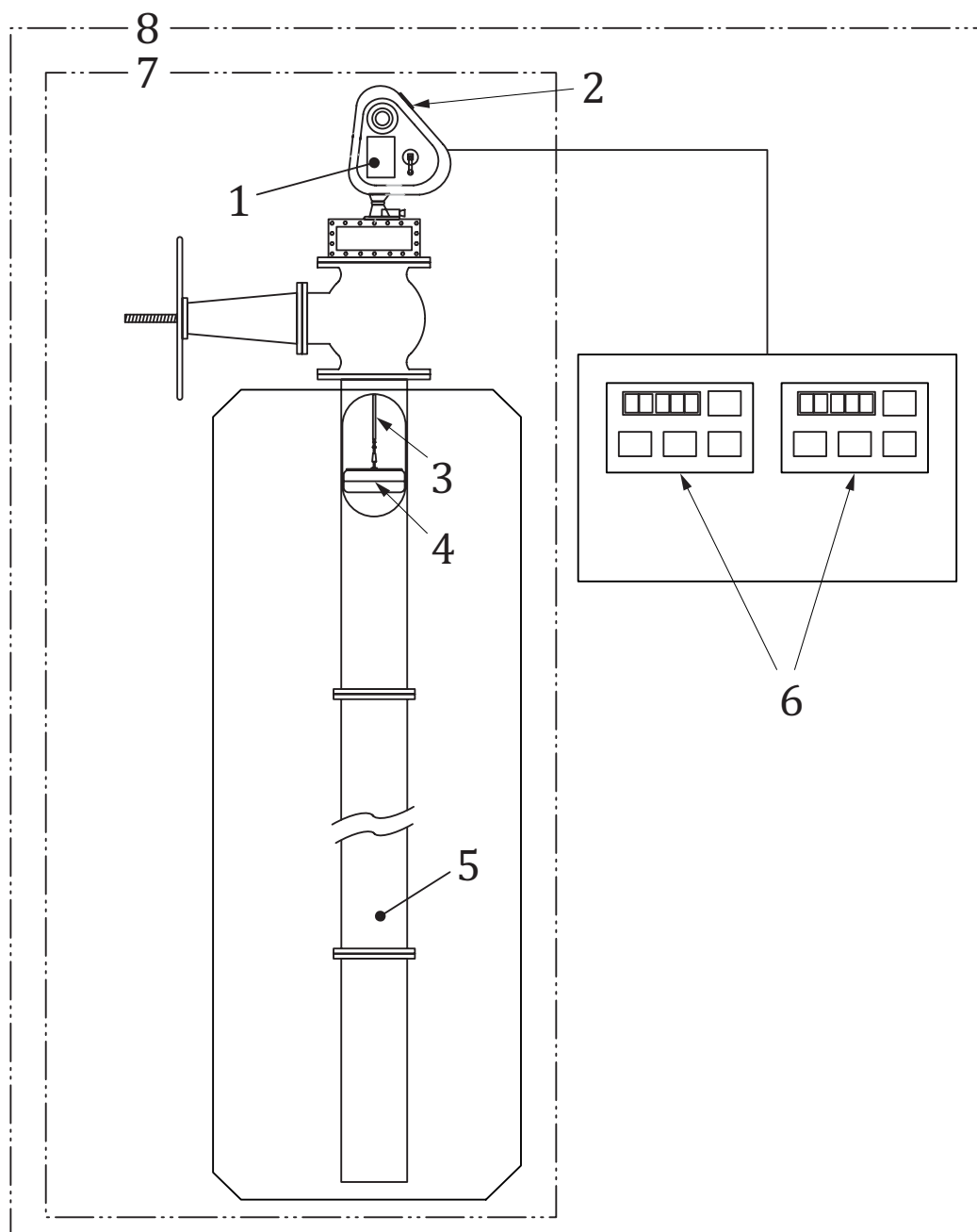

Key

- | | | | |
|---|---------------|---|--------------------------|
| 1 | gauge head | 5 | perforated stilling well |
| 2 | local display | 6 | remote display |
| 3 | float tape | 7 | ATG |
| 4 | float | 8 | ATG system |

Figure 2 — Float gauge

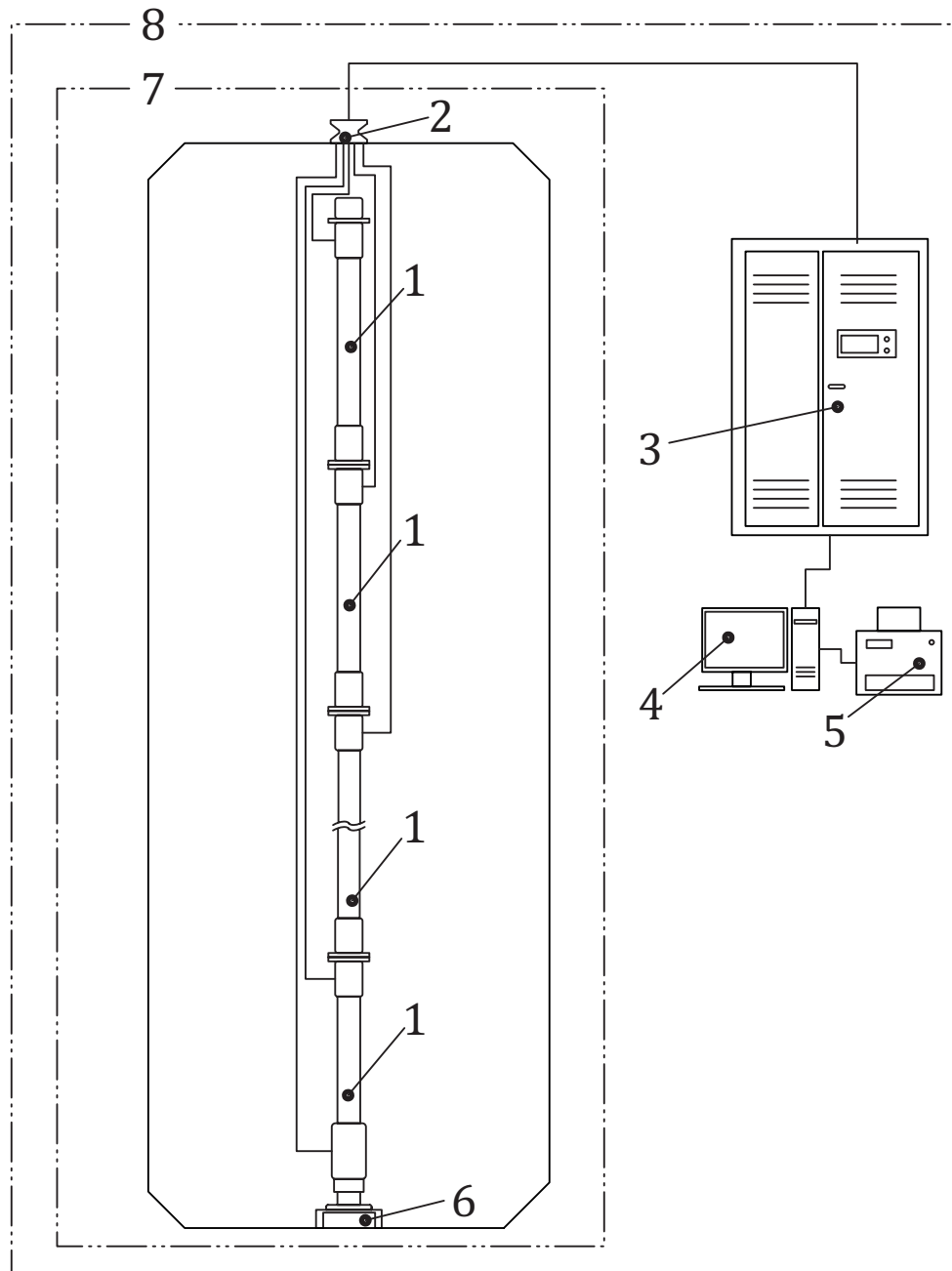

Key

- | | |
|----------------|--------------|
| 1 electrode | 5 printer |
| 2 feed-through | 6 pedestal |
| 3 control unit | 7 ATG |
| 4 display unit | 8 ATG system |

Figure 3 — Capacitance gauge

5.6.7 Temperature measurement equipment

The calculation and determination of the liquid cargo density is a function of the liquid temperature. As such, liquid cargo density is very sensitive to temperature; therefore, obtaining accurate temperature

readings is critical. For example, a change of 0,2 °C for liquid methane cargo results in approximately a 0,07 % change in density.

A multiple-spot automatic tank thermometer (ATT) (see [3.1.22](#)) with an averaging function shall be used for temperature measurement. ISO 8310 may provide guidance for calibration and field verification. The equipment shall be designed to measure the low temperatures encountered in LNG service as defined in EN 1160.

There should be a minimum of five temperature sensors in each tank and at least one temperature sensor shall be located above the maximum fill height so as to remain in the vapour space. Each temperature sensor shall be supported by a secondary sensor mounted adjacent to the primary temperature sensor. The ATT system shall read and provide individual temperatures for both liquid and vapour space and allow their averages to be determined. Smaller LNG carriers may have fewer temperature sensors; however, IGC Code requires a minimum of three.

The lowest temperature sensor shall be located near the bottom of the tank so as to measure the temperature of the heel.

Sensors shall be positioned in such manner as not to directly expose them to spray from the cool-down nozzles.

5.6.8 Pressure measurement equipment

A pressure sensor is required at an appropriate position to measure the vapour space pressure. The pressure sensor shall be calibrated or verified to meet the requirements set forth in applicable API, ISO and relevant industry standards, as well as the requirements of the vessel's flag administration and classification societies.

5.6.9 Custody transfer measurement system

5.6.9.1 The CTMS processes all of the on board LNG carrier measurement information. It monitors and records the following inputs:

- a) level;
- b) temperature;
- c) pressure;
- d) trim and list.

The CTMS performs numerous functions and calculations including

- averaging readings over time,
- filtering readings,
- applying corrections, i.e. thermal, trim, list, pressure,
- determining volumes using computer-based tank capacity tables, and
- generating custody transfer reports.

5.6.9.2 A CTMS shall incorporate at least the following calculations using the measurements of level, temperature and pressure and data from the tank capacity tables (for examples of tables, see [Annex C](#)):

- a) level gauge correction for trim and list;
- b) level gauge correction for vapour temperatures;
- c) volumes, corrected for temperature where applicable.

The CTMS shall be designed and built such that any software or entries that can impact the determined quantities are secure from tampering or unauthorized revision.

The CTMS shall generate applicable reports for opening and closing events (following/prior to loading/discharge, etc.). See examples in [Annex D](#). Note that there can be a local requirement for cargo density to be used in the CTMS for mass determination.

5.7 Dynamic measurement systems and equipment

At the time of publication of this International Standard, technologies, such as Coriolis and ultrasonic flow meters, are available, but are not yet in common usage for LNG custody transfer measurement. These and other technologies continue to develop and are becoming more widely used in LNG service. These systems may be used for custody transfer subject to agreement by all parties involved.

6 Measurement procedures

6.1 General

6.1.1 Procedures to measure the parameters needed to determine the quantity of cargo loaded or discharged on board an LNG carrier are described in this Clause. The custody transfer measurement system shall be operated by the ship's crew.

Vital aspects of good measurement of cargo on board LNG carriers include the use of proper tables and algorithms, the accurate recording of the basic data obtained through physical measurement and the correct calculation of the necessary quantities. These quantities are usually calculated by the CTMS and, if so, steps shall be taken to verify that the CTMS are certified or re-certified (see [5.3](#)). These procedures detail those items which are essential to accurately determine cargo quantities.

If an independent inspector is appointed, all measurements and gauging shall be witnessed and verified by the independent inspector. The results of such independent inspector verifications shall be made available promptly to each party. If measurement procedures are not followed or a discrepancy is found, a notice of apparent discrepancy or letter of protest shall be issued.

Measurement of cargo on board an LNG carrier should be carried out in accordance with this International Standard or well-defined and agreed conditions stipulated by terminal procedures, local and governmental regulation and the SPA.

To determine the LNG quantity on board, the following shall be obtained:

- a) liquid level;
- b) temperature;
- c) pressure;
- d) sample(s) and composition.

When performed, the following shall also be considered in determining the LNG quantity transferred:

- cool down;
- gassing up.

6.1.2 The following details the procedures to obtain the required measurements to determine the LNG quantity on board.

Prior to taking shipboard measurements, confirm that

- a) all cargo operations have been stopped, e.g. liquefaction plants, gas combustion units (GCUs), fuel gas pumps, LNG vaporizers, forcing vaporizers, spray pumps, ballasting or other operations which affect transfer quantities (see [Annex A](#)), and that the cargo tanks are in a static condition,
- b) the state of BOG compressor usage is understood,
- c) BOG measurement techniques are set for gas used in the ship engines, if any,
- d) sufficient time has elapsed for the cargo to stabilize and reach equilibrium conditions of temperature and pressure (for a detailed checklist, see [Annex F](#)),
- e) operations affecting trim and list, i.e. ballast, bunker transfer or cargo movements, should be suspended during the custody transfer measurement process,
- f) deck piping volumetric fill condition is known and accounted for, and
- g) the method is in place for determining the quantity of the vapour returned during loading or discharge operations.

During the cargo transfer process, boil-off gas (BOG) may be used as fuel for the ship's engines. Parties may explicitly agree to allow gas consumption in the ship's engine room during the time between the opening and closing custody transfer surveys. The BOG used for fuel by the vessel in port should be quantified. The method of quantifying the BOG consumed in the engines, if any, should be agreed upon by the parties involved.

Trim and list shall be optimized and kept unchanged while custody transfer measurement tasks are performed. Generally, vessel trim and list should be minimized at the time of measurement whenever the cargo tanks are full, but may require other conditions where partial cargoes are being measured. For operational and commercial reasons, a substantial trim to the aft may even be recommended whenever performing stripping of the cargo tanks.

Record the trim and list and apply corrections made for their affect on measurement and/or quantities (see [B.4](#), [Figures B.1](#) and [B.2](#)). The CTMS usually can accept and automatically apply the corrections for manually-entered trim and list data or trim and list data received from external sensors.

6.2 Static measurement

6.2.1 General

The parties involved, as deemed by contract or mutual agreement, shall select the primary level measurement system to be used to determine the quantity on board the vessel, provided the system is functioning properly and for which a certified tank capacity table exists. Tank capacity tables shall be available and their certification verified as specified in [5.6.2](#). A level measurement system without certified tank capacity tables is not acceptable as either a primary or secondary level measurement system.

The same level measurement system (i.e. primary or secondary) shall be used for both opening and closing custody transfer. For example, if the level gauge normally designated as the primary measurement system was inoperative at the time of opening gauging, necessitating the use of the secondary level gauge, the secondary shall be used again at the time of closing gauging even if the primary level gauge has been corrected in the interim. Similarly, if the level gauge normally designated as the primary measurement system fails after the opening gauging, necessitating the use of the secondary level gauge for the closing reading, the secondary readings shall be used for both the opening and the closing.

All tank readings, to the extent possible, shall be taken and recorded at the same time, including primary and secondary level gauge readings, pressures and temperatures. If both the primary and

secondary system are inoperable or unreliable, all parties shall be notified and alternative methods used in accordance with contractual requirements or by mutual agreement.

6.2.2 Measuring liquid level

Level measurement is most accurately performed with a stable liquid surface. Boil off or vessel motion affects the stability of the liquid surface. Where taking opening or closing gauges, effort should be made to ensure the liquid surface is as stable as possible given the loading/discharge conditions.

At a minimum, five successive gauge readings should be taken and averaged to obtain the level measurement. Additional readings are advisable under certain conditions, for example, where readings vary excessively. For additional discussion, see [B.6](#).

6.2.3 Loading

For loading, make the first set of readings after the loading arms have been connected, but before the manifold valves have been opened prior to commencement of cool down. These readings enable the determination of the quantity of LNG remaining on board as cooling liquid, also called heel. A second set of readings shall be made after the end of loading, once the surface of the liquid is nearly stabilized and the vapour arms are purged and closed. Delivery lines, including ship piping, manifolds and loading arms, used for loading and/or discharging should be in volumetrically similar condition where opening and closing custody transfer measurements are carried out. It is possible not to be able to positively confirm or achieve this condition. If this condition cannot be achieved because of port regulation or physical constraints, it should be documented.

6.2.4 Discharge

For discharge, make the first set of readings prior to commencement of discharge when the unloading arms have been connected and prior to starting to cool them down. A second set of readings shall be made upon completion of discharge once the arms are drained and purged. Ideally, the readings are taken after the liquid surface is nearly stable. The vapour return line(s) typically remain connected, but closed, until on board gas burning has resumed. It is possible that this does not apply to LNG carriers with reliquefaction capabilities or gas combustion units (GCU).

6.2.5 Shipboard measurements

In order to measure the quantity of cargo in the vessel's tanks, the following parameters shall be accurately determined for the various measurement systems:

- a) the liquid level in the tank;
- b) trim;
- c) list;
- d) the average temperature of the liquid;
- e) the average temperature of the vapour;
- f) the pressure of the vapour in the tank;
- g) any change to ATG filter settings shall be recorded;
- h) any other information needed to make corrections to specific equipment used.

The use of any measurement equipment fitted on board the vessel to achieve these objectives requires observance of all appropriate safety procedures as well as the manufacturer's specific instructions.

6.2.6 Liquid level

6.2.6.1 General

The primary ATG shall be identified at the key meeting and used for both opening and closing gauges unless it malfunctions. In that case, the secondary system shall be used for both gauges. Both the primary and the secondary ATG readings shall be recorded. Secondary measurements shall be taken concurrently with primary measurements or as soon after as practicable. Verify level measurement equipment in accordance with ISO 18132-1.

The secondary ATG shall always be in operation. This provides a level gauge for comparison to the primary ATG and a means to monitor the primary ATG for malfunction.

NOTE It is recognized that this procedure cannot guarantee that the device accuracy meets its original certified value. However, cross checking and tracking the history provide an indication of the performance of the ATGs on the vessel.

In addition to the foregoing, the following guidelines should also be followed.

- a) Where possible, the ATG shall be functionally tested by means of an appropriate measure, such as a test run immediately prior to commencement of the custody transfer or other equivalent means, as described in ISO 18132-1. For example, a microwave gauge can be checked against the verification pin, and a float gauge can be checked at its fully-retracted top storage or at its grounded position.
- b) Determine whether the ATG provides a level reading or the tank volume at that level.
- c) Ensure that the measurement equipment has stabilized and adjusted to the temperature of the cargo being measured and that all corrections for temperature and/or pressure are made as required.
- d) Follow the manufacturer's specific operating procedures and use them to supplement these procedures.

If any of the preceding steps cannot be complied with, the reasons should be noted, and the appropriate letter of protest filed.

6.2.6.2 Radar (microwave) gauges

Verify the level reading according to the manufacturer's instructions and record the filter settings, if any. Once the tank level is sufficiently stabilized, observe and record the level gauge reading from the control panel which is typically located in the cargo control room of the LNG carrier.

For some microwave level gauges, a temperature compensation of the microwave guide pipe is necessary. Most systems can accept trim and list data either manually or from external sensors and automatically apply all necessary corrections.

6.2.6.3 Float gauges

The float gauge should be checked for accuracy at its top storage position and its grounded position according to manufacturer's instructions. If this verification is satisfactory, the level readings can be recorded.

If the level indication is unexpectedly high, low or unchanging, the float could be stuck. In this situation, it is suggested that it be raised and lowered again in an attempt to obtain the expected reading.

The top storage position in which the float has been stowed is typically at a higher temperature than the liquid surface, so that whenever the float contacts the cargo surface, the liquid underneath of the float boils and the resulting turbulence can cause the displayed reading to be unstable. More stable readings may be obtained by leaving the float in contact with the liquid until temperature equilibrium is achieved.

The float should not be lowered at a high speed, especially whenever the liquid level is low. High-speed lowering of the float can damage the float, tape or wire due to excessive shock whenever it reaches the liquid surface.

The readings made on the float gauge system should be corrected using appropriate tables or formulae according to

- a) list,
- b) trim,
- c) density of LNG, affecting float buoyancy,
- d) temperatures of liquid and gaseous phases affecting reference gauge height in accordance with the contraction coefficient of the tank material, and
- e) temperature of gaseous phase, affecting the shrinkage of float tape or wire in accordance with the contraction coefficient of its material.

6.2.6.4 Capacitance gauges

Once the tank level is stabilized, observe and record the level gauge reading from the control panel, which is typically located in the cargo control room of the LNG carrier.

Some older capacitance gauges can have higher uncertainty outside of their normal load range levels (near-full and near-empty tank conditions). It is possible that measurements in this intermediate zone do not meet the requirements of this International Standard. Special attention shall be given to measuring partial cargoes measured with these older devices.

6.2.7 Temperature

6.2.7.1 General

The temperatures in each tank shall be determined at the same time as the liquid levels. Each temperature sensor shall be read and recorded. Temperature sensor readings in each tank are averaged for those in the liquid phase and again for those in the vapour phase. If it is inconclusive as to whether a sensor is in the gas-liquid interface zone or if there is any doubt about the accuracy of a sensor, the reading should be disregarded.

The average temperature should be calculated with each sensor representing its proportional volume of cargo which is known as quantity weighting. Quantity weighting may be achieved by appropriate sensor spacing or by volume weighting each measured temperature. If quantity weighting is not achieved, the arithmetic average temperature of the liquid shall be used.

Verify temperature measurement equipment in accordance with ISO 8310. Temperature verification may be performed by comparing the primary and secondary sensor readings in the liquid phase of the same or other cargo tank(s).

NOTE It is recognized that this procedure cannot guarantee that the device accuracy meets its original certified value. However, cross checking and tracking the history provide an indication of the performance of the temperature measuring equipment on the vessel.

6.2.7.2 Temperature of liquid

The temperature of the liquid shall be measured by using the temperature sensor(s) immersed in the liquid cargo at the time of measurement. Determine which sensors are in the liquid cargo and which are in the vapour space based on the liquid level from the gauging system. Where the system allows, disregard any temperature sensor affected by boiling action at the vapour-liquid interface. If a similar quantity of cargo is transferred from each of the cargo tanks, calculate the average liquid temperature

by an arithmetic average of all sensor readings in the liquid. Where tank volumes vary significantly, the parties may agree to apply a quantity-weighted average temperature.

6.2.7.3 Temperature of vapour

The temperature of the vapour shall be measured using the temperature sensor(s) in the vapour phase of the tank at the time of measurement. Use the level readings to select the temperature sensors above the vapour/liquid interface. All temperature sensors in the vapour space should be used and not just the sensor above the maximum liquid level. Where the system allows, disregard any sensors affected by boiling action near the vapour-liquid interface. Calculate the average vapour temperature as the arithmetic average of all temperature readings from all tanks.

6.2.8 Pressure

6.2.8.1 General

The absolute pressure of cargo tanks shall be measured at the same time as the measurement of the tank's levels and temperatures. The vapour pressure sensor can normally be isolated from the tank, and a pressure calibrator is then connected to the sensor in order to verify the accuracy of the pressure readout.

6.2.8.2 Pressure measurement

Read and record the pressure for each tank. Under typical operating configurations, the tank pressures are equalized through the vapour header. For systems measuring gauge pressure, obtain and add the atmospheric pressure as appropriate. Where needed for calculation purposes, obtain the atmospheric pressure existing at the same time as the tank pressure is measured. Because the LNG carrier's quarters and control room are pressurized, atmospheric pressure should be based on outside air.

6.2.9 CTMS

6.2.9.1 General

Virtually all LNG carriers use the CTMS to calculate shipboard quantities (see [5.6.9](#)).

6.2.9.2 Calculations and reports

Generate the reports for the closing or opening gauge by providing suitable commands to the CTMS. Verify the content of the reports by comparison to manual calculations or direct observations of measurements. These reports should be reviewed by affected parties, signed and retained with other custody transfer documentation.

6.2.10 Sampling

6.2.10.1 General

The heating value and density are typically based on the cargo composition given by the analysis of the representative sample obtained at the terminal. It is possible that these parameters are not available prior to the LNG carrier departing from the terminal. The composition of the return gas could also be required.

The custody transfer process involves calculation of a delivered energy value from measured volumes and composition, which depends on sample and gas chromatograph accuracy. ISO 8943 gives details of LNG sampling equipment, which shall be used to obtain representative samples. Sampling and analysis requirements may be specified in the SPA or other agreements. See [Annex E](#) and the *GIIGNL LNG Custody Transfer Handbook*^[10] for additional details.

6.2.10.2 LNG sampling verification

Prior to the arrival of the vessel, the parties or their appointed independent inspector shall

- a) confirm the primary and backup location(s) for both liquid and vapour return (if applicable) and determine if samplers are continuous or intermittent,
- b) confirm continuous sample containers are clean, and
- c) confirm that the gas chromatograph(s) have been calibrated or verified in accordance with terminal procedures and/or contractual requirements.

6.2.11 Vapour return

6.2.11.1 General

Part of the custody transfer measurement process includes quantification of vapour return either by the ship or by the shore. The determination of the amount of vapour returned involves measuring or assuming the composition and calculating the resulting gas properties for the vapour return gas. The SPA may define assumptions or accounting treatment for the vapour return quantities.

6.2.11.2 Procedures

If appointed, the independent inspector should understand and follow the procedures stated in the SPA regarding returned vapour and any specific sampling technique or frequency. If these aspects are not addressed in the SPA or terminal procedures, an agreed upon methodology should be established prior to custody transfer.

6.3 Gas-up and cool-down quantification

6.3.1 General

Whenever the vessel first enters service or returns to service after dry dock or layup, the cargo tanks shall be purged and cooled down once the vessel arrives at the loading terminal in order to be in a condition to receive cargo. LNG from the terminal is used to first gas up and then cool down the tanks. The quantity used to gas up and to cool down shall be determined. The SPA usually describes the method to be used to determine these amounts and the vessel's cool-down tables are normally used in this process.

6.3.2 Inerting

The purpose of inerting the cargo tanks is to remove oxygen prior to loading cargo. Since cargo is not used for this operation, inerting should not affect the cargo quantification.

6.3.3 Gas up and cool down

6.3.3.1 General

Terminals may prescribe specific actions for cool down and methods of calculation for determining the quantity of LNG used. Determine the quantity of LNG used for cool down and perform calculations as agreed upon by all parties. Various methods exist, as described in [5.6.5](#).

When used, confirm that the cool-down tables are appropriate for the composition of LNG received; otherwise, issue a letter of protest.

6.3.3.2 Cool-down procedures

The determination that the vessel's tanks have reached their required temperature is established by the vessel with notification to the loading terminal and the independent inspector, if appointed, so that the cool-down quantity can be determined. Under normal operating conditions, cool down should take between 8 h and 12 h for membrane-type LNG carriers, and 16 h to 20 h for vessels with spherical tanks.

The cool-down table provides for the calculation of the volume of LNG required from either actual or representative historical composition for the specific loading terminal. Follow the instructions in the cool-down tables. The heating value and density can be calculated from the composition. Once the mass of LNG is determined, its volume can be calculated.

For cool-down table and calculation details, see [C.1](#) and [C.2](#), in particular [Table C.8](#).

6.4 Dynamic measurement

At the time of publication of this International Standard, static measurement is the only way to determine the cargo quantities on board LNG carriers. However, dynamic systems may be used for custody transfer subject to agreement by all parties involved. If a flow meter is installed in an LNG loading or discharge facility or an floating storage and regasification unit (FSRU) to measure the quantity for verification or custody transfer purposes, various industry guidelines for dynamic measurement of other fluids may provide guidance on their use (see [5.7](#)).

7 Cargo calculations

7.1 General

This Clause outlines the information needed and steps required to calculate the volume of an LNG cargo. Specific circumstances can require specialized considerations, calculations and/or additional steps.

The calculation of LNG quantities is performed in two parts. Firstly, the quantity transferred is determined by measuring the volume on board the vessel prior to and following loading or discharge. Secondly, the amount of energy transferred is determined from the volume transferred by applying the cargo density and its heating value.

The determination of the mass and energy transferred requires analysis of samples taken onshore. The procedure and calculations are outlined in [Annex D](#).

7.2 LNG volume determination

7.2.1 General

One significant feature of LNG carriers is that while in service, their cargo tanks are 100 % occupied by measurable cargo in its vapour and/or liquid phase. In this regard, the volume of vapour returned is assumed to be equal to that of the displaced liquid.

In accordance with the instructions noted in the tank capacity table, obtain the corrected liquid level in millimetres applying any necessary corrections to the apparent liquid level (see [6.2.6](#)).

Calculate the volume of LNG in the cargo tanks, in units of cubic metres expressed to three decimal places, corresponding to the above-mentioned corrected liquid level prior to and following loading and/or discharging. The volume of LNG, in cubic metres loaded or discharged, is then calculated as the volume difference obtained from the output of the opening and closing custody transfer measurements.

Some tanks require correction for the thermal expansion or contraction of the tank. In this case, the correction shall be determined using the tank thermal correction table and the average tank temperature (see [5.6.2.4](#)).

Delivery lines to be used for loading and/or discharging should be in a volumetrically similar condition at the opening and closing of custody transfer.

NOTE LNG CTMS calculations do not usually take vapour mass into account in the calculations, either before or after discharge (or loading). Allowance is made in calculations for gas returned back on board the ship in the commercial reconciliation of the heat energy transferred.

Due to the shape of the tank and the location of the level measurement system, it could be impossible to accurately measure small amounts of heel [quantity remaining on board (ROB)/on board quantity (OBQ)] left in the tank. This situation should be noted and recorded on the cargo documents.

7.2.2 Liquid levels below lower measurable limit

Where a heel is to be left on board, the cargo should not be discharged below the minimum measurable level. However, if the level is below the minimum measurable level, the unpumpable quantities specified in the ship charter party or SPA should be used.

7.3 LNG density determination

The density of the LNG liquid cargo is normally calculated based on the composition determined by gas chromatograph of a representative sample from the loading/unloading line during transfers to/from the terminal. Various equations of state, including the Klosek-McKinley method or its revised version, may be used to calculate the density based on the chemical composition and liquid temperature.

At the time of publication of this International Standard, it is not common for density to be determined by direct measurement for custody transfer purposes.

Annex A (informative)

LNGC design and marine operations

A.1 LNG carrier design

A.1.1 General

LNG carriers may be fitted with tanks of varying design. Each design can require unique measurement and operational considerations. The types of tanks commonly used in the LNG trade are membrane tanks and IMO Type B. In addition, a small number of IMO Type C tanks are in service. These are described in [A.2](#).

[Figures A.1](#) to [A.4](#) are for illustrative purposes only.

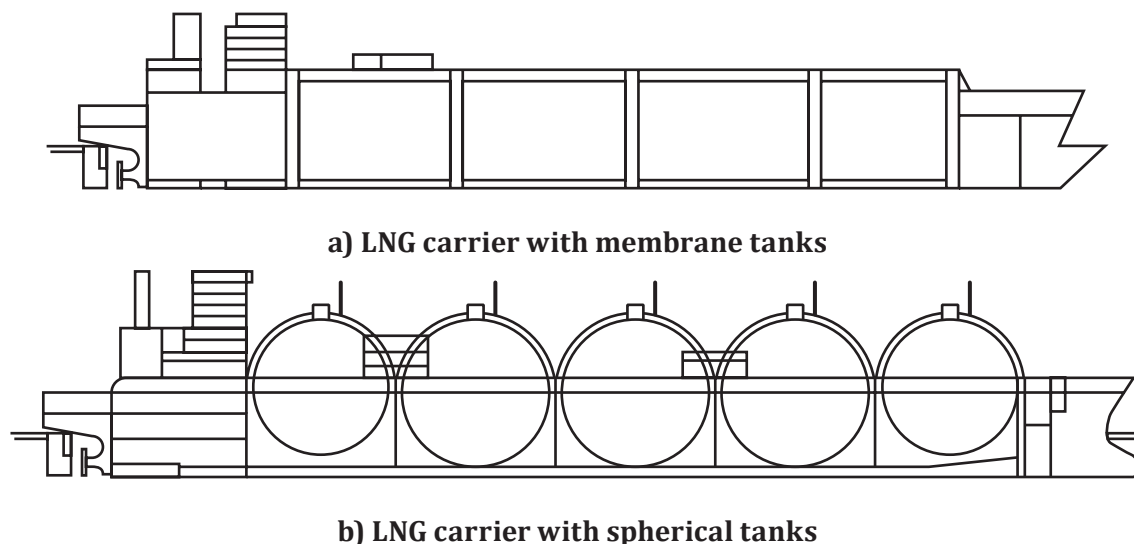

Figure A.1 — Simplified longitudinal-sectional view of LNG carriers (not to scale)

A.1.2 LNG carriers

All LNG carriers have double hulls running through the length of the cargo area, which provide adequate space for ballast. Ships fitted with the membrane tanks have a full secondary barrier and ships fitted with spherical or prismatic IMO Type B tanks have a partial secondary barrier to protect the inner bottom of the vessel. Continuous gas monitoring of all hold spaces is required.

A.2 Types of cargo tanks

The following tank types as defined by the gas codes (see the note to [3.1.13](#)) are applicable to LNG carriers.

- a) Membrane tanks are non-self-supporting tanks that consist of a thin layer (membrane) supported through insulation by the adjacent hull structure. The membrane is designed in such a way that thermal and other expansion or contraction is compensated for without undue stressing of the membrane.

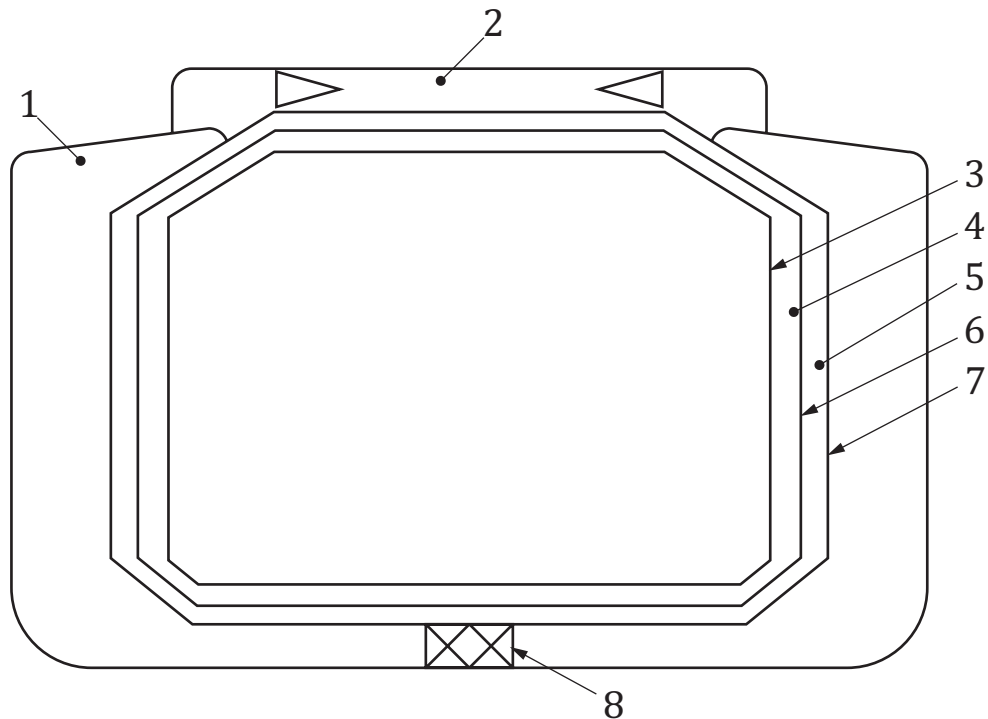

Key

- | | | | |
|---|-----------------------------------|---|-----------------------------------|
| 1 | water ballast tank | 5 | inter-barrier space or insulation |
| 2 | void space | 6 | secondary barrier |
| 3 | primary barrier | 7 | inner hull |
| 4 | inter-barrier space or insulation | 8 | double-bottom pipe passage |

Figure A.2 — Simplified cross-section of a membrane tank (not to scale)

- b) Independent tanks are self-supporting; they do not form part of the ship's hull and are not essential to the hull strength including prismatic, spherical and pressurized tanks.
- 1) IMO Type B tanks: The most common design of IMO Type B tanks is the Moss spherical tank. Type B tanks are designed using model tests, refined analytical tools and analysis methods to determine stress levels, fatigue life and crack propagation characteristics.

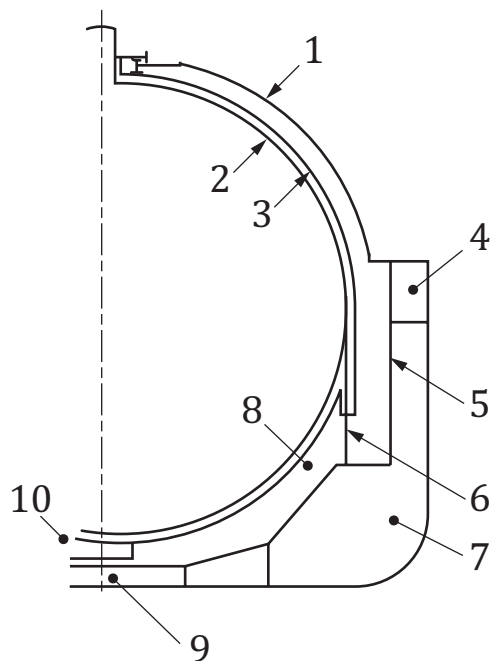

Key

- | | | | |
|---|--|----|--------------------------------------|
| 1 | water-proof tank cover | 6 | supporting skirt |
| 2 | aluminium alloy tank body | 7 | water ballast tank |
| 3 | insulation (can contain a nitrogen bleed system) | 8 | hold space |
| 4 | upper deck passageway | 9 | double bottom pipe passage |
| 5 | inner hull | 10 | drip pan (partial secondary barrier) |

Figure A.3 — Simplified cross-section of a spherical tank (not to scale)

2) IMO Type C tanks are heavy tanks since they are designed to recognized pressure vessel code and therefore are limited to small sizes. A minimum design pressure is specified to qualify for Type C based on size of the tank, the density of the cargo and the tank material. Vessels with Type C tanks are designed with cargo capacity of approximately 1 000 m³ to 12 000 m³.

IMO Type C tanks are used for short coastwise service where the voyage is so short that they load the cargo cold and let it warm up during the voyage which builds up the pressure. Most are designed for 35 kPa to 400 kPa.

The IMO Type C tank does not require any secondary barrier because the design is based on the concept that the governing stress is the membrane stress due to pressure (hoop stress) and that the fluctuating stress due to bending and pressure surge is very small compared to the general membrane stress so the fluctuating stress is not high enough to cause fatigue failure.

Type C tanks used for LNG are normally stainless steel but aluminium or 9 % nickel steel can be used.

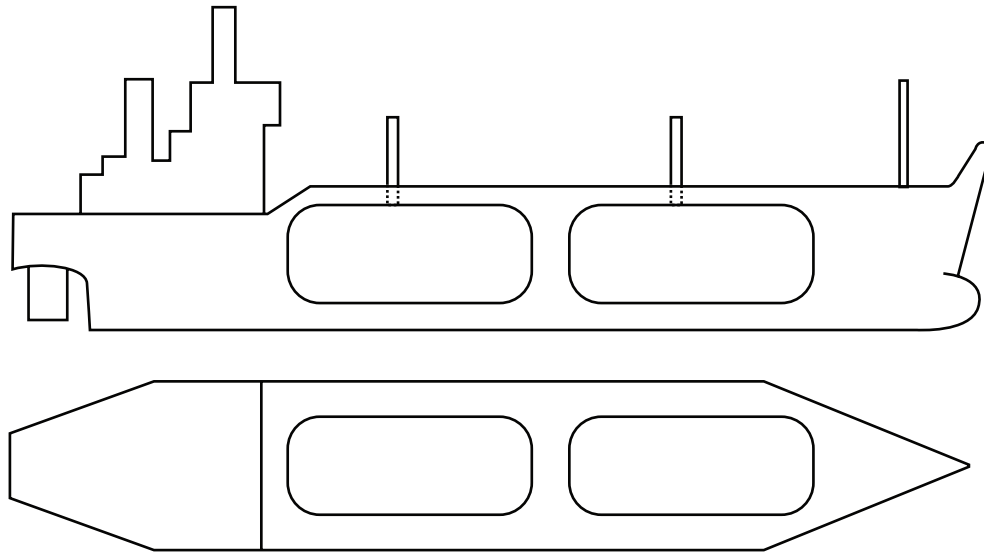

Figure A.4 — Vessel with IMO Type C tanks

A.3 Measurement-related operational notes

A.3.1 Putting tanks in service

A.3.1.1 General

The sequence of activities given in [A.3.1.2](#) and [A.3.1.3](#) is typically performed where tanks are initially put into service or after they have been taken out of service.

The following operational items should be considered where measuring and/or accounting for LNG measurement quantities. Most of the following steps are only performed after tanks are prepared for repair, inspection or shipyard visit. This assumes that the vessel is at the beginning of a cycle, i.e. newly built or leaving dry dock and starts with tanks gas free. The following cycle of operation is given for informational guidance only and is not to be considered an operationally complete document. For additional details on this process, see *SIGTTO Liquefied Gas Handling Principles on Ships and in Terminals*.

A.3.1.2 Tank preparation

A.3.1.2.1 Tank inspection

On LNG carriers in continuous service, this operation is normally carried out at the building yard/refit yard prior to its entering/re-entering into service, as en route to the first loading port it would go through the drying/inerting cycles below. To do this, the tank shall be certified gas-free for safe entry and at ambient temperature.

The cleanliness of the cargo system is essential to protect the terminal and ships tanks from impact damage arising from any debris left in the lines. Mesh filters are usually used at the manifolds in LNG service for providing such protection. In the case of debris being found, however small, it is normal to carry out extensive investigations to determine the source; often, the remains are weighed and sent ashore for laboratory analysis to determine the source and ensure that all debris has been recovered. The manifold filters should be inspected prior to and following completion of cargo operations at both the load and discharge port. If debris is found in the filters, a letter of protest should be issued.

A.3.1.2.2 Drying

Remove moisture by using ambient or heated inert gas or dry air with a suitable dew point from the ship or shore and/or through use of an air-drying system.

A.3.1.2.3 Inerting

After the tanks have been approved for carriage of cargo, the air shall be removed from the tanks. This is carried out by inerting by displacement until the oxygen content is below 2 %. Terminal regulations can specify a lower value for oxygen content.

A.3.1.2.4 Gassing up

Once the tank atmosphere is acceptable, inert gas shall be displaced with warm gas vapours of the cargo to be loaded. The LNG to produce these warmed-up gas vapours can come from the shore or from another on board cargo tank using the LNG carrier's vaporizer and BOG heater. The cost of performing these activities is determined by terminal regulations and the SPA.

A.3.1.2.5 Cool down

Once the tank is gassed up with the vapour of the cargo to be loaded, the tanks shall be cooled down to appropriate loading temperature to prevent undue stress and excessive cargo vaporization. This is usually achieved by receiving a quantity of cargo from the shore or from tanks on the vessel. Usually the tank(s) shall be cooled down before the quantity in the tank can be accurately determined. Cool down should be at rates considered safe by the tank designers. There can be a significant difference in the cool-down rates between spherical and membrane tanks. Thus, cool down can be an extended process to avoid excessive thermal stresses in the tank structures, such as in the equator rim of a spherical tank.

The method of cooling down the tanks and the source of the cargo used for the process should be noted and accounted for in the cargo inspection report. Appropriate cool-down tables should be used in this process. If liquid cargo is found to be in the tanks after the cool-down process, the amount should be determined, recorded and treated as cargo already loaded or as otherwise addressed in the SPA and/or cool-down tables.

A.3.1.3 Loading

Receiving cargo from the shore or lightering vessel causes vaporization of cargo in the tanks of the vessel being loaded. When colder LNG is pumped into a warmer receiving tank, vaporization occurs.

LNG carriers, which are equipped with re-liquefaction plants, can lack the capacity to handle the relatively larger quantities of rapidly vaporized gas which can be generated during the loading operations. The resulting vapour is returned ashore or to the lightering vessel.

LNG carriers have fill limits as determined by Formula (A.1) from the IGC Code:

$$V_{LL} = \frac{V_{FL} \times \rho_R}{\rho_L} \quad (\text{A.1})$$

where

V_{LL} is the percentage load limit (LL);

V_{FL} is the filling limit (FL) (usually 98,5 %);

ρ_R is the relative density of the cargo at reference temperature;

ρ_L is the relative density of the cargo at loading temperature and pressure.

NOTE The IGC Code allows the vessel's flag administration to set a higher filling limit (FL) than the limit of 98,5 % specified at the reference temperature, taking into account the shape of the tank, arrangements of pressure relief valves, accuracy of level and temperature gauging and the difference between the loading temperature and the temperature corresponding to the vapour pressure of the cargo at the set pressure of the pressure relief valve. The maximum filling limit is not to exceed 99,5 % at the reference temperature.

The reference temperature for Formula (A.1) is the temperature corresponding to the vapour pressure of the cargo at the set pressure of the relief valves.

A.3.2 During service

A.3.2.1 General

Personnel performing measurement procedures should be made aware of the specific relevant safety and operational requirements for the LNG carrier and its cargo.

A.3.2.2 Prior to loading

Specific conditions of carriage should be determined prior to loading, including any relevant terminal regulations and restrictions enforced at the load and discharge ports. For details of the pre-cargo transfer meeting, see ISO 28460.[\[6\]](#)

If the forgoing preparation process is required, any amount of product used in the process should be accounted for.

Due to the continuous nature of the LNG trade, a tank inspection at any time occurs only due to extraordinary circumstances, e.g. reason to suspect that there is damage to the tank or mechanical breakdown within the tank.

A.3.2.3 During loading

While loading the liquid cargo, vapour in the tanks shall be displaced to allow liquid into the tanks. The amount of vapour returned to the shore should be accounted for in accordance with terminal regulations and/or the SPA.

A.3.2.4 During transit

During the transit from the load port to the discharge port, the cargo boils off to some extent. The boil-off rate is in the order of 0,15 % of the cargo per day and may be used to fuel the ship's engines. As a matter of economics or to meet environmental requirements, the vessel may choose to force boil off to be used in place of traditional marine fuels. The amount of BOG consumed in transit may be measured or estimated and should be accounted for in accordance with contractual requirements (see [B.7](#)). The boil-off or liquefaction conditions are often used to monitor the performance of the cargo system.

NOTE Some newer ships have the capability to capture and liquefy the BOG.

A.3.2.5 Prior to discharge

Arrival opening quantities should be compared against departure closing quantities to determine any vessel in-transit differences, which may include voyage gas consumption. If the actual boil-off rate exceeds the contractual rate, a letter of protest should be issued and the causes investigated if deemed applicable. For details of expected LNG boil-off, see [B.7](#). For details of the pre-cargo transfer meeting, see ISO 28460.^[6]

A.3.2.6 During discharge

Any vapours returned to the LNG carrier should be accounted for in accordance with terminal regulations and the SPA.

A.3.2.7 After discharge

On completion of the cargo discharge, the heel shall be measured for liquid level, vapour pressure and the vapour/liquid temperature to determine the quantity remaining on board. LNG carriers in continuous service often intentionally sail from the discharge port with heel to maintain the tank temperatures and cargo tanks in a ready-to-load state on arrival at the loading port.

A.3.3 Taking tanks out of service

A.3.3.1 General

In some cases, such as preparations for tank entry or laying up (taking the ship out of service), the ship's tank may be totally emptied of liquid cargo in a process referred to as "heeling out" (also referred to as stripping). After "heeling out", the vessel uses regular bunker fuel to steam at sea (for aerating, arrival at dry dock and to load port). If an LNG carrier tank is to be taken out of service for inspection or maintenance, the following sequence of activities is normally followed.

A.3.3.2 Discharging of liquid cargo

Under some commercial contracts, LNG carriers do not discharge their entire cargo, but keep a small quantity of heel in the tanks. This ensures arrival at the loading port with tanks at a temperature whereby they can be loaded without delay; this also provides BOG for fuel on the ballast passage. The amount of heel left on board is accounted for as described in [Annex D](#).

Under other commercial contracts or where the LNG carrier is going to dry dock, the tanks are emptied of cargo, which is a process known as heeling out. If the LNG carrier's tanks are to be emptied for inspection or service, the steps specified in [A.3.3.3](#) to [A.3.3.5](#) are also taken.

A.3.3.3 Warming up

Warming up of the cargo tanks after cargo discharge is vital on LNG carriers if the tanks are going to be completely emptied and aerated. During this process, compressors and heaters are operated to circulate warm gas into the tank. This process evaporates any residual liquid and then eventually warms up the whole tank to required conditions.

A.3.3.4 Inerting — After discharge

Where tanks are opened for internal inspection, inerting is always a necessary step. This is to reduce the hydrocarbon content within tank atmospheres to a safe level before aerating the tank with fresh air.

A.3.3.5 Aerating

Once tanks have been safely inerted, the cargo tanks may be ventilated with fresh, dry air, following all safety procedures and industry practices. Aeration should continue until "SAFE FOR HUMAN ENTRY" levels are achieved and maintained in accordance with occupational health and safety regulations.

Once the tank is fully aerated and a tank entry permit issued, the tank may be entered for inspection with the permission of the Master or designated person in charge of the LNG carrier.

Annex B (informative)

Additional considerations for measurement on board an LNGC

B.1 General

This Annex contains additional information and cautionary notes regarding measurement accuracy and determination of vessel quantities. Additional considerations that should be taken during the measurement of these cargoes are as follows (in [B.2](#) to [B.7](#)).

B.2 Re-calibration and re-certification

Re-calibration of the equipment listed in [5.1](#) is normally carried out while the ship is at the shipyard for dry docking by a qualified third party (i.e. an independent calibration agency or manufacturer). In some uncommon cases, a measurement device can be re-calibrated in the interim. In either case, the result of the re-calibration should be re-certified.

In the case of any modification to a tank that affects the integrity of the tank capacity table, the tank capacity table shall be updated prior to reuse.

B.3 Control charts

Control charts or equivalent records should be maintained by the vessel and made available where requested. The comparison over time of a reading to a known value or the comparison of primary and secondary measurements may be evaluated through a control chart.

The control chart provides a tolerance or control band for each device which can be used to assess the measurement integrity of the device. Frequent use of a device can result in its output drifting away from the true reading in an amount exceeding the tolerance. At this point, it is time to reset the device or recalibrate. An appropriate verification frequency can detect errors and provide confidence in continuing device integrity with the least amount of effort.

B.4 Draft readings and trim and list corrections

B.4.1 LNG carriers not on even keel — With trim and list

For most accurate measurement on LNG carriers, ships should be on even keel at the time of gauging. Prismatic and membrane type vessels are more sensitive to trim and list during gauging than ships with spherical tanks. Trim and list readings and type of tanks shall be included in the custody transfer measurement documentation.

Cargo volume calculations shall be adjusted for trim and list as defined in the tank capacity tables. Unlike crude oil and product tankers, virtually all of the LNG carriers' cargo tanks are calibrated to include trim and list corrections for the tanks in all conditions of fill. If this is found not to be the case however, full details of the exception and any action taken accordingly shall be listed in the cargo inspection report.

B.4.2 Draft readings

Draft readings shall be taken prior to and following loading and discharging. Draft readings are used to determine the following:

- a) the depth of the vessel in the water;
- b) the trim and list of the vessel;
- c) whether or not the vessel is loaded correctly.

Draft marks are displayed in customary or metric units. The numerals for customary units are 15,24 cm (6 in.) high and are spaced 15,24 cm (6 in.) apart. Readings are made from the bottom of the numerals and estimated to the inch (see [Figure B.1](#)).

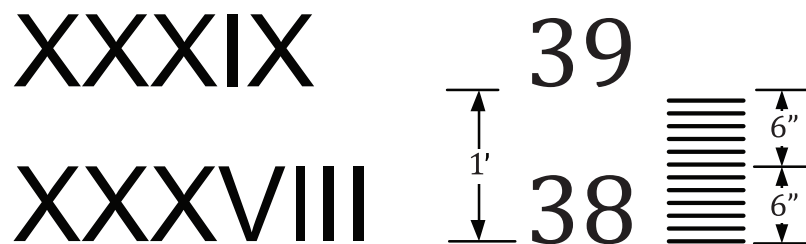

Figure B.1 — Draft readings — US customary units

The numerals for metric units may be displayed in even decimetres, with markings 10 cm (4 in.) high and spaced 10 cm (4 in.) apart (see [Figure B.2](#)) or every 0,2 m (8 in.). Readings are made from the bottom of the numerals and estimated to the centimetre (see [Figure B.2](#)).

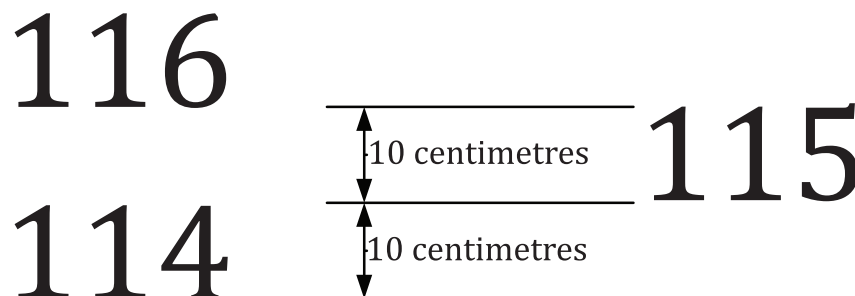

Figure B.2 — Draft readings — SI units

Vessel draft readings should be visually observed. However, if this is not possible, draft may be determined using automatic draft measuring systems, e.g. pressure sensors or electro-pneumatic systems. The method of obtaining draft should be recorded in the cargo documentation.

By manual/visual reading the forward/aft scales from quay/berth side, one can expect an error of 50 mm for each reading, which for a 270 m length ship, typically renders an uncertainty of 5,7 mm in the trim calculation.

NOTE The length of the tank and distance from the aft bulkhead to the gauge are assumed to be 45 m and 0,85 m, respectively.

On the other hand, a modern electro-pneumatic draft measurement system (with digital communication) has a typical uncertainty of 2 cm to 3 cm, which for the trim calculation renders a much lower uncertainty than “reading the scales”. For the list calculation, the only suitable manual measurement is by tape over the rail; supposing an error of 20 mm per reading, typically renders an uncertainty of 0,04° in the list calculation for a 40 m-wide ship. This is equal to that provided by a modern electro-pneumatic draft measurement system (with digital communication).

A modern (electro-pneumatic) four-point draft measurement can thus render a higher accuracy of the ship overall trim and list than the measurements from control room located inclinometers or manual draft measurements.

B.4.3 Determination of trim and list

All attempts should be made to correct any list the vessel has prior to taking measurements. If this cannot be done, a vessel's list may be accurately determined in the following two ways:

- a) by reading the appropriate inclinometer;
- b) by reading the differences between starboard and port drafts and then calculating the list.

Where a vessel is not on even keel and/or is listing at the time of gauging, the vessel's trim and/or list shall be taken into account in order to accurately determine the liquid quantities on board. To do so, the instructions found in the vessel's trim/list tables shall be followed to make the required adjustments for any trim or list noted.

B.5 Vessel experience factor (VEF)

The LNG custody transfer quantity is determined by gauging on board the LNG carrier rather than onshore; consequently, it is not possible to determine the VEF in the same manner as is done for other cargoes. As a result, VEFs are not applied to LNG carriers.

NOTE While, in theory, a VEF for LNG carriers can be determined, it is difficult, if not impossible, to get a true ship-shore comparison because of the circumstances of usual cargo operations, including a lack of consistent shore figures, vessel heel, boil off and ship-shore vapour exchange.

B.6 Ship-to-ship transfers and other offshore activities

B.6.1 General

Ship-to-ship transfers of LNG cargoes are now becoming part of the business model for some LNG vessel operators. Cargo measurements taken offshore during these operations should generally be performed in the same manner as measurements at a shore berth. Many offshore operations are conducted at exposed berths, which can cause the ship to be in rolling or pitching motion during the time of measurement. In those situations, special care should be taken to ensure accurate gauges of cargo levels are obtained. Additionally, it can be impossible to take draft readings to the resolution specified in [Table 1](#). Any other special considerations at each berth should also be taken into account in the measurement process (see [B.6.2](#)).

Floating storage and regasification units (FSRU) can be unable to perform standard gauging procedures due to concurrent internal loading and discharge operations. Measurement procedures to address quantity determination should be developed as part of the contractual agreement.

B.6.2 Measurement on board LNG carriers at an exposed mooring location

During offshore operations or lightering, or where the LNG carrier is at an exposed berth, cargo can be in motion within the LNG carrier's tanks. In such situations, at least five successive observed readings should be taken, then the highest and lowest readings dropped and the remaining three averaged and recorded. The successive gauge readings are to be taken as quickly as is practicable; a description and extent of the adverse measurement conditions should be recorded.

Filtering of level and trim/list may be necessary to get measurement readings for opening and closing gauge.

B.7 LNG as fuel

B.7.1 Measurement of LNG boil-off gas as fuel

At the time of publication of this International Standard, LNG boil-off gas (BOG) is the only refrigerated cargo permitted for use as fuel for the LNG carrier's boilers or engines as specified by the gas codes (see the note to 3.1.13). Some LNG carriers are fitted with a reliquefaction plant and this subclause is not applicable to those vessels unless the BOG is used as fuel.

Heat transfer to the tanks causes natural boil off, thereby increasing tank pressures. BOG may be used as fuel in the LNG carrier's boilers or multi-fuel engines, reliquefied or disposed of in a gas combustion unit.

Daily boil-off rates during the voyage vary as a function of a number of conditions, including cargo and tank temperatures, and cargo composition. Agitation of the cargo due to sea state and barometric pressures are factors which also affect boil off. Management of the boil-off rate may be achieved through controlling tank pressures by varying the gas compressor speeds and/or gas consumption in the ship's machinery. Cargo tank pressures should never be allowed to fall below atmospheric. Though actual rates vary from ship to ship, typical figures for LNG carrier boil-off rates are in the order of 0,15 % of the cargo quantity per day during the loaded voyage [see Formula (B.1)] and 0,1 % per day for the ballast voyage. It should be noted that LNG often contains a small percentage of nitrogen, which boils off preferentially, thus reducing the heating value of the BOG at the beginning of the loaded voyage. This evaporation of lighter hydrocarbons and nitrogen (from the liquid cargo) can result in a change in the composition of LNG by the time the LNG carrier arrives at port.

The average daily boil-off rate, B_D , as a percentage, is calculated by Formula (B.1):

$$B_D = \frac{(V_S - V_A)}{(D_S \times V_T)} \times 100 \quad (\text{B.1})$$

where

V_S is the sailing volume;

V_A is the arrival volume;

D_S is the days at sea;

V_T is the total capacity of the vessel.

The charterer's instructions or SPA can require the use of LNG as fuel for the ship's engines at sea. However, the amount of natural BOG may be insufficient to meet the total fuel demand. In this case, LNG from the cargo tanks is fed through the forced vaporizer to augment the natural BOG burned in the propulsion and auxiliary machinery. The quantity used as forced BOG is reconciled in the measurement of cargo prior to discharge.

NOTE The net amount of BOG could be substantially reduced in the future because of liquefaction, improved tank insulation and the use of pressure build-up tanks.

B.7.2 LNG as fuel in port

Environmental concerns over ship emissions in some ports can necessitate the use of vaporized LNG as fuel to meet the requirements of the LNG carrier's usage for its own functions (accommodation heating or cooling, power generation, etc., also known as hotelling) and cargo operations. Gas consumed for such purposes is usually covered by the natural boil off in the ship's tanks and/or return gas from shore. In the event that a vessel is equipped with a dynamic measurement system that satisfies the accuracy and verification standards for measurement equipment, actual measurement of consumed cargo for hotelling and discharge operations shall be used to reconcile the measurement of cargo following discharge (see D.6).

Annex C (informative)

Examples of tank capacity tables for a spherical tank

C.1 Tank capacity tables for a spherical tank — Examples

Table C.1 — Example of section of a tank capacity table

Gauge m	Volume m ³	Difference m ³	Gauge m	Volume m ³	Difference m ³	Gauge m	Volume m ³	Difference m ³
36,10	35 258,908	5,869	36,60	35 540,310	5,374	37,10	35 796,635	4,865
36,11	35 264,777	5,859	36,61	35 545,684	5,365	37,11	35 801,500	4,855
36,12	35 270,636	5,849	36,62	35 551,049	5,355	37,12	35 806,355	4,845
36,13	35 276,485	5,840	36,63	35 556,404	5,345	37,13	35 811,200	4,834
36,14	35 282,325	5,829	36,64	35 561,749	5,334	37,14	35 816,034	4,824
36,15	35 288,154	5,821	36,65	35 567,083	5,325	37,15	35 820,858	4,814
36,16	35 293,975	5,810	36,66	35 572,408	5,315	37,16	35 825,672	4,803
36,17	35 299,785	5,800	36,67	35 577,723	5,304	37,17	35 830,475	4,793
36,18	35 305,585	5,791	36,68	35 583,027	5,295	37,18	35 835,268	4,782
36,19	35 311,376	5,781	36,69	35 588,322	5,284	37,19	35 840,050	4,772
36,20	35 317,157	5,771	36,70	35 593,606	5,274	37,20	35 844,822	4,762
36,21	35 322,928	5,762	36,71	35 598,880	5,264	37,21	35 849,584	4,751
36,22	35 328,690	5,751	36,72	35 604,144	5,254	37,22	35 854,335	4,740
36,23	35 334,441	5,742	36,73	35 609,398	5,244	37,23	35 859,075	4,731
36,24	35 340,183	5,732	36,74	35 614,642	5,234	37,24	35 863,806	4,720
36,25	35 345,915	5,722	36,75	35 619,876	5,224	37,25	35 868,526	4,709
36,26	35 351,637	5,713	36,76	35 625,100	5,213	37,26	35 873,235	4,699
36,27	35 357,350	5,702	36,77	35 630,313	5,203	37,27	35 877,934	4,689
36,28	35 363,052	5,693	36,78	35 635,516	5,194	37,28	35 882,623	4,678
36,29	35 368,745	5,683	36,79	35 640,710	5,183	37,29	35 887,301	4,667
36,30	35 374,428	5,673	36,80	35 645,893	5,173	37,30	35 891,968	4,657
36,31	35 380,101	5,663	36,81	35 651,066	5,163	37,31	35 896,625	4,647
36,32	35 385,764	5,653	36,82	35 656,229	5,152	37,32	35 901,272	4,636
36,33	35 391,417	5,644	36,83	35 661,381	5,143	37,33	35 905,908	4,626
36,34	35 397,061	5,633	36,84	35 666,524	5,132	37,34	35 910,534	4,615
36,35	35 402,694	5,624	36,85	35 671,656	5,122	37,35	35 915,149	4,605
36,36	35 408,318	5,614	36,86	35 676,778	5,112	37,36	35 919,754	4,594
36,37	35 413,932	5,604	36,87	35 681,890	5,101	37,37	35 924,348	4,584
36,38	35 419,536	5,594	36,88	35 686,991	5,092	37,38	35 928,932	4,573
36,39	35 425,130	5,584	36,89	35 692,083	5,081	37,39	35 933,505	4,562
36,40	35 430,714	5,574	36,90	35 697,164	5,071	37,40	35 938,067	4,553

Table C.1 (continued)

Gauge m	Volume m ³	Difference m ³	Gauge m	Volume m ³	Difference m ³	Gauge m	Volume m ³	Difference m ³
36,41	35 436,288	5,565	36,91	35 702,235	5,061	37,41	35 942,620	4,541
36,42	35 441,853	5,554	36,92	35 707,296	5,051	37,42	35 947,161	4,531
36,43	35 447,407	5,545	36,93	35 712,347	5,040	37,43	35 951,692	4,521
36,44	35 452,952	5,534	36,94	35 717,387	5,030	37,44	35 956,213	4,510
36,45	35 458,486	5,525	36,95	35 722,417	5,020	37,45	35 960,723	4,499
36,46	35 464,011	5,515	36,96	35 727,437	5,009	37,46	35 965,222	4,489
36,47	35 469,526	5,505	36,97	35 732,446	5,000	37,47	35 969,711	4,478
36,48	35 475,031	5,494	36,98	35 737,446	4,989	37,48	35 974,189	4,467
36,49	35 480,525	5,485	36,99	35 742,435	4,979	37,49	35 978,656	4,457

Table C.2 — Example of section of a trim correction table

Corrections in millimetres

Gauge m	3,0 m B/H	2,5 m B/H	2,0 m B/H	1,5 m B/H	1,0 m B/H	0,5 m B/H	0,0 m EVEN	0,5 m B/S	1,0 m B/S	1,5 m B/S	2,0 m B/S	2,5 m B/S	3,0 m B/S
35,00	-14	-12	-9	-7	-5	-2	0	2	4	6	8	10	12
35,50	-14	-12	-9	-7	-5	-2	0	2	4	6	8	10	12
35,60	-14	-12	-9	-7	-5	-2	0	2	4	6	8	10	12
35,70	-14	-12	-9	-7	-5	-2	0	2	4	6	8	10	12
35,80	-14	-12	-9	-7	-5	-2	0	2	4	6	8	10	12
35,90	-14	-12	-9	-7	-5	-2	0	2	4	6	8	10	12
36,00	-14	-12	-9	-7	-5	-2	0	2	4	6	8	10	12
36,10	-14	-12	-9	-7	-5	-2	0	2	4	6	8	10	12
36,20	-14	-12	-9	-7	-5	-2	0	2	4	6	8	10	12
36,30	-14	-12	-9	-7	-5	-2	0	2	4	6	8	10	12
36,40	-14	-12	-9	-7	-5	-2	0	2	4	6	8	10	12
36,50	-14	-12	-9	-7	-5	-2	0	2	4	6	8	10	12
36,60	-14	-12	-9	-7	-5	-2	0	2	4	6	8	10	12
36,70	-14	-12	-9	-7	-5	-2	0	2	4	6	8	10	12
36,80	-14	-12	-9	-7	-5	-2	0	2	4	6	8	10	12
36,90	-14	-12	-9	-7	-5	-2	0	2	4	6	8	10	12
37,00	-14	-12	-9	-7	-5	-2	0	2	4	6	8	10	12
37,10	-14	-12	-9	-7	-5	-2	0	2	4	6	8	10	12
37,20	-14	-12	-9	-7	-5	-2	0	2	4	6	8	10	12
37,30	-14	-12	-9	-7	-5	-2	0	2	4	6	8	10	12
37,40	-14	-12	-9	-7	-5	-2	0	2	4	6	8	10	12

NOTE Where B/H is trim by the head (toward the bow), EVEN means even keel and B/S is trim by the stern (toward the stern).

Table C.3 — Example of section of a list correction table

Corrections in millimetres

Gauge m	List to port							List to starboard						
	3,0°	2,5°	2,0°	1,5°	1,0°	0,5°	0,0°	0,5°	1,0°	1,5°	2,0°	2,5°	3,0°	
35,00	15	15	15	13	9	5	0	-6	-14	-22	-32	-43	-54	
35,50	15	15	14	12	9	5	0	-6	-14	-22	-32	-43	-55	
35,60	14	15	14	12	9	5	0	-6	-14	-23	-32	-43	-55	
35,70	14	15	14	12	9	5	0	-6	-14	-23	-32	-43	-55	
35,80	14	15	14	12	9	5	0	-6	-14	-23	-32	-43	-55	
35,90	14	15	14	12	9	5	0	-6	-14	-23	-32	-43	-56	
36,00	14	14	14	12	9	5	0	-6	-14	-23	-33	-44	-56	
36,10	14	14	14	12	9	5	0	-6	-14	-23	-33	-44	-56	
36,20	14	14	14	12	9	5	0	-6	-14	-23	-33	-44	-56	
36,30	13	14	14	12	9	5	0	-6	-14	-23	-33	-44	-56	
36,40	13	14	14	12	9	5	0	-6	-14	-23	-33	-44	-56	
36,50	13	14	14	12	9	5	0	-6	-14	-23	-33	-44	-56	
36,60	13	14	14	12	9	5	0	-6	-14	-23	-33	-44	-57	
36,70	13	14	13	12	9	5	0	-6	-14	-23	-33	-44	-57	
36,80	13	14	13	12	9	5	0	-6	-14	-23	-33	-44	-57	
36,90	13	14	13	12	9	5	0	-6	-14	-23	-33	-44	-57	
37,00	13	14	13	12	9	5	0	-6	-14	-23	-33	-45	-57	
37,10	13	14	13	12	9	5	0	-6	-14	-23	-33	-45	-57	
37,20	13	14	13	12	9	5	0	-6	-14	-23	-33	-45	-57	
37,30	13	14	13	12	9	5	0	-6	-14	-23	-33	-45	-58	
37,40	13	14	13	12	9	5	0	-6	-14	-23	-33	-45	-58	

Table C.4 — Example of section of thermal correction table for a radar-type level gauge

Corrections in millimetres

Gauge m	Vapour temperature °C												
	-160	-158	-156	-154	-152	-150	-148	-146	-144	-142	-140	-138	-136
30	-144	-144	-144	-144	-143	-143	-142	-142	-142	-141	-141	-140	-140
31	-144	-144	-144	-143	-143	-143	-142	-142	-142	-141	-141	-140	-140
32	-144	-144	-144	-143	-143	-143	-143	-142	-142	-141	-141	-140	-140
33	-144	-144	-144	-143	-143	-143	-143	-142	-142	-141	-141	-141	-140
34	-144	-144	-144	-143	-143	-143	-143	-142	-142	-142	-141	-141	-141
35	-144	-144	-143	-143	-143	-143	-143	-142	-142	-142	-141	-141	-141
36	-144	-144	-143	-143	-143	-143	-143	-142	-142	-142	-142	-141	-141
37	-144	-144	-143	-143	-143	-143	-143	-142	-142	-142	-142	-141	-141
38	-144	-144	-143	-143	-143	-143	-143	-143	-142	-142	-142	-142	-141
39	-144	-144	-143	-143	-143	-143	-143	-143	-143	-142	-142	-142	-142

Table C.5 — Example of section of thermal correction table for a tank shell

Liquid temperature °C	Correction factor	Liquid temperature °C	Correction factor	Liquid temperature °C	Correction factor	Liquid temperature °C	Correction factor
-165,0	0,999 86	-161,0	0,999 97	-157,0	1,000 08	-153,0	1,000 19
-164,9	0,999 86	-160,9	0,999 98	-156,9	1,000 09	-152,9	1,000 20
-164,8	0,999 87	-160,8	0,999 98	-156,8	1,000 09	-152,8	1,000 20
-164,7	0,999 87	-160,7	0,999 98	-156,7	1,000 09	-152,7	1,000 20
-164,6	0,999 87	-160,6	0,999 98	-156,6	1,000 09	-152,6	1,000 20
-164,5	0,999 88	-160,5	0,999 99	-156,5	1,000 10	-152,5	1,000 21
-164,4	0,999 88	-160,4	0,999 99	-156,4	1,000 10	-152,4	1,000 21
-164,3	0,999 88	-160,3	0,999 99	-156,3	1,000 10	-152,3	1,000 21
-164,2	0,999 88	-160,2	0,999 99	-156,2	1,000 10	-152,2	1,000 22
-164,1	0,999 89	-160,1	1,000 00	-156,1	1,000 11	-152,1	1,000 22
-164,0	0,999 89	-160,0	1,000 00	-156,0	1,000 11	-152,0	1,000 22
-163,9	0,999 89	-159,9	1,000 00	-155,9	1,000 11	-151,9	1,000 22
-163,8	0,999 90	-159,8	1,000 01	-155,8	1,000 12	-151,8	1,000 23
-163,7	0,999 90	-159,7	1,000 01	-155,7	1,000 12	-151,7	1,000 23
-163,6	0,999 90	-159,6	1,000 01	-155,6	1,000 12	-151,6	1,000 23
-163,5	0,999 90	-159,5	1,000 01	-155,5	1,000 12	-151,5	1,000 23
-163,4	0,999 91	-159,4	1,000 02	-155,4	1,000 13	-151,4	1,000 24
-163,3	0,999 91	-159,3	1,000 02	-155,3	1,000 13	-151,3	1,000 24
-163,2	0,999 91	-159,2	1,000 02	-155,2	1,000 13	-151,2	1,000 24
-163,1	0,999 91	-159,1	1,000 02	-155,1	1,000 14	-151,1	1,000 25

Table C.6 — Example of section of a thermal correction table for float-type level gauge

Corrections in millimetres

Gauge m	Vapour temperature °C												
	-160	-158	-156	-154	-152	-150	-148	-146	-144	-142	-140	-138	-136
30	-138	-138	-138	-138	-138	-137	-137	-136	-136	-136	-135	-135	-135
31	-139	-138	-138	-138	-138	-138	-137	-137	-137	-136	-136	-135	-135
32	-139	-139	-139	-138	-138	-138	-138	-137	-137	-137	-136	-136	-136
33	-139	-139	-139	-139	-139	-138	-138	-138	-137	-137	-137	-136	-136
34	-140	-139	-139	-139	-139	-139	-138	-138	-138	-138	-137	-137	-137
35	-140	-140	-140	-139	-139	-139	-139	-139	-138	-138	-138	-138	-137
36	-140	-140	-140	-140	-140	-140	-139	-139	-139	-139	-138	-138	-138
37	-141	-140	-140	-140	-140	-140	-140	-140	-139	-139	-139	-139	-138
38	-141	-141	-141	-141	-140	-140	-140	-140	-140	-140	-139	-139	-139

Table C.7 — Example of section of density correction table for a float-type level gauge

Range of density kg/m ³	Correction mm
420,0 to 424,1	5
424,2 to 433,5	4
433,6 to 443,4	3
443,5 to 453,6	2
453,7 to 464,4	1
465,5 to 475,7	0
475,8 to 487,5	-1
487,6 to 500,0	-2

Table C.8 — Example of cool-down table for spherical tanks

Starting equator temperature	Sprayed LNG required to cool equator temperature to -110 °C	Cool-down time required	LNG heel	Actual LNG used for cool down	Energy required to reach equator temperature of -110 °C
°C	MT	h	MT	MT	MMBtu
30	297	13,6	60	237	11 034
25	290	13,3	59	231	10 765
20	281	12,9	55	225	10 486
15	272	12,4	53	219	10 210
10	265	12,0	51	214	9 939
5	255	11,5	47	208	9 672
0	249	11,1	47	202	9 374
-5	239	10,6	44	195	9 060
-10	230	10,1	41	189	8 792
-15	222	9,7	39	183	8 495
-20	213	9,3	37	176	8 197
-25	203	8,8	34	169	7 883
-30	197	8,4	32	165	7 694
-35	188	8,0	30	158	7 350
-40	179	7,6	28	151	7 006
-45	169	7,2	25	144	6 708
-50	160	6,8	23	137	6 364
-55	150	6,4	21	129	6 020
-60	141	6,0	19	122	5 675
-65	132	5,6	17	115	5 331
-70	120	5,1	13	107	4 971

NOTE Assumptions made in this table are the following:

- LNG density = 470 kg/m³;
- unit heat value = 46 520 Btu/kg (lower heating value of LNG);
- cargo cool-down table (one tank) at 5 °C intervals.

Table C.8 (continued)

Starting equator temperature	Sprayed LNG required to cool equator temperature to -110 °C	Cool-down time required	LNG heel	Actual LNG used for cool down	Energy required to reach equator temperature of -110 °C
°C	MT	h	MT	MT	MMBtu
-75	110	4,7	12	98	4 580
-80	101	4,3	10	91	4 236
-85	89	3,8	7	82	3 829
-90	80	3,4	6	74	3 438
-95	68	2,9	4	64	2 984
-100	54	2,3	1	53	2 468
-105	42	1,8	3	45	1 845
-110	0	0	0	0	0

NOTE Assumptions made in this table are the following:
 — LNG density = 470 kg/m³;
 — unit heat value = 46 520 Btu/kg (lower heating value of LNG);
 — cargo cool-down table (one tank) at 5 °C intervals.

C.2 Example of calculation of cool-down quantities

For a spherical tank, [Table C.8](#) shows that a total of 11 034 MMBtu has to be removed from the tank to cool it from 30 °C to -110 °C. This is equal to 237 t of LNG if the LNG has a heating value of 46 520 Btu/kg. Actual cool-down quantities vary as a function of the density and heating value of LNG.

As an example, assume a heating value of 52 417 Btu/kg for the LNG used to cool down the tank.

$11\,034\,000 / 52\,417 = 210,5$ t of LNG are needed for cool down, which equates to 489,2 m³, based on a density of 430,3 kg/m³. [Table C.8](#) indicates that 237 t of LNG are needed to cool down from 30 °C to -110 °C, which equates to 504,3 m³, based on the data density of 470 kg/m³. The difference between the LNG used in the table and the LNG actually used in the calculations is 15,1 m³ or 3 %, due to the difference in the heating value of the LNG.

Under the same temperature conditions and LNG heating value, a membrane tank requires significantly less LNG to cool down to cargo temperature because the mass of the tank is smaller.

Other methods may be used as mutually agreed upon or as indicated in the SPA.

Annex D (informative)

Calculation examples

D.1 Example of an LNG cargo calculation

The mass of LNG, loaded or discharged, shall be calculated in accordance with industry methods, such as ISO 6578[2] or as specified in contractual requirements.

The cargo calculation includes the volume, mass and heating value of liquid and vapour, loaded or discharged from the LNG carrier. It shall include determination of composition, such as through gas chromatographic analysis of representative samples, to determine LNG density and heating value. Most LNG cargoes are calculated as energy transferred according to specific contractual methods.

NOTE In the case of online gas chromatographs, the average value of all valid data points is used for calculation.

Figure D.1 illustrates the typical steps to calculate the energy transferred during loading in a custody transfer operation.

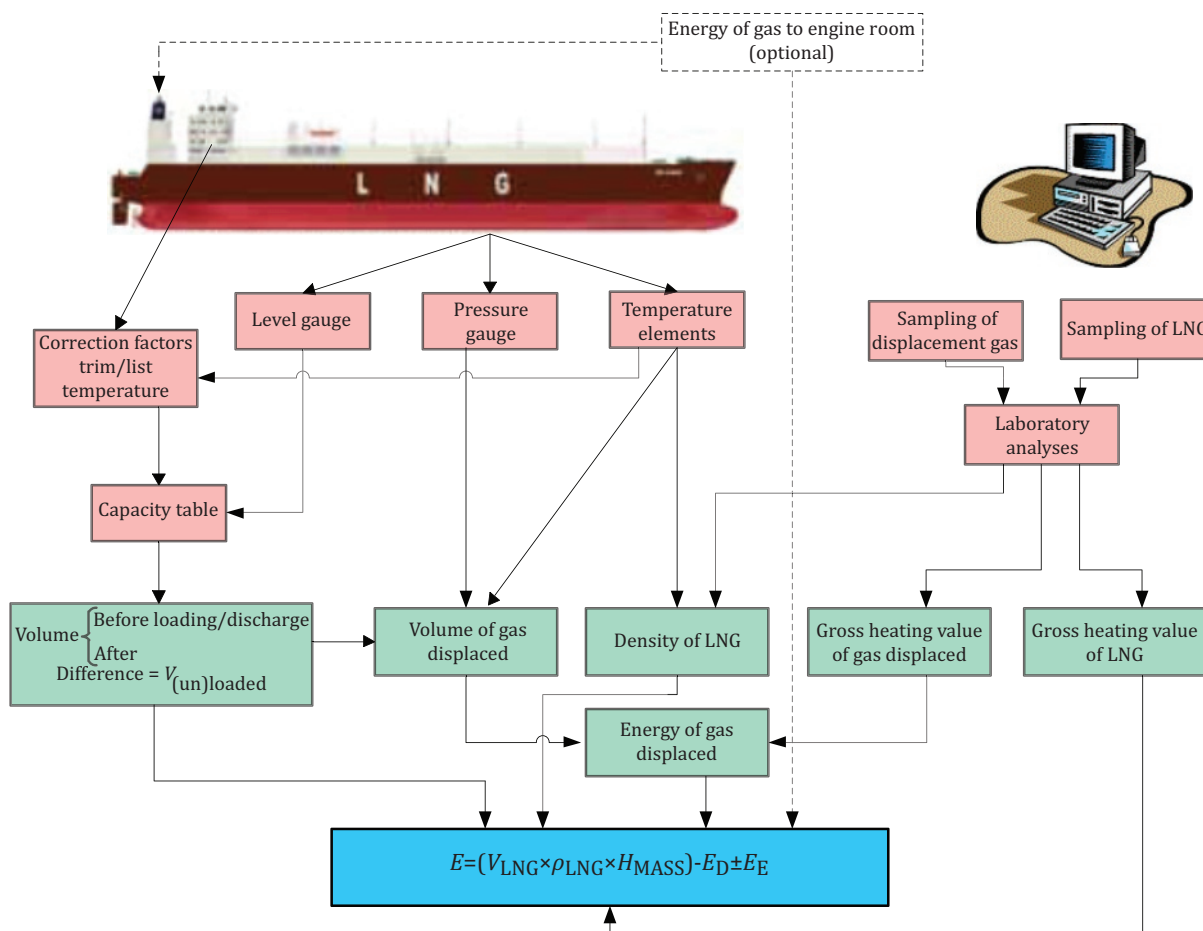

Figure D.1 — Cargo calculation flow chart for quantity and energy

SHIP NAME
DATE
LOCAL TIME
PORT NAME
CARGO NO
CHIEF OFFICER

TRIM (m) 0,05 BY STERN
LIST (DEGREE) 0,10 TO STARBOARD

LEVEL (m)	TANK 1	TANK 2	TANK 3	TANK 4
No.1	37,332	37,050	37,488	37,388
No.2	37,333	37,051	37,488	37,390
No.3	37,332	37,051	37,487	37,391
No.4	37,332	37,051	37,487	37,392
No.5	37,332	37,051	37,486	37,392
AVERAGE LEVEL (m)	37,332	37,051	37,487	37,391

TRIM CORRECTION (m)	0,000	0,000	0,000	0,000
LIST CORRECTION (m)	-0,001	-0,001	-0,001	-0,001
THERMAL CORRECTION (m)	-0,140	-0,141	-0,141	-0,141
CORRECTED LEVEL (m)	37,191	36,909	37,345	37,249
LIQUID VOLUME (m ³)	35 840,527	35 701,728	35 912,842	35 868,054
VOLUME SUMMED (m ³)	143 323,151	@ -160 °C		
THERMAL EXPANSION FACTOR	1,000 02	@ -159,2 °C		
CORRECTED LIQUID VOLUME (m ³)	143 326,017	@ -159,2 °C		

TEMPERATURE (°C)								
100 %	-131,96	V	-137,24	V	-134,68	V	-137,58	V
75 %	-159,30	L	-159,24	L	-159,33	L	-158,62	L
50 %	-159,31	L	-159,25	L	-159,36	L	-158,61	L
25 %	-159,34	L	-159,23	L	-159,40	L	-158,79	L
0 %	-159,31	L	-159,24	L	-159,36	L	-158,94	L

TANK AVG VAPOUR TEMP (°C)	-132,0	-137,2	-134,7	-137,6
SHIP'S AVG VAPOUR TEMP (°C)	-135,4			

TANK AVG LIQUID TEMP (°C)	-159,3	-159,2	-159,4	-158,7
SHIP'S AVG LIQUID TEMP (°C)	-159,2			

TANK VAPOUR PRESSURE (kPa(a))	112,2	111,9	112,2	112,2
SHIP'S AVG VAPOUR PRESSURE (kPa(a))	112,1			

	COMPANY	NAME
SHIP'S MASTER	_____	_____
BUYER(S)	_____	_____
SELLER(S)	_____	_____
CARGO INSPECTOR	_____	_____

Figure D.2 — Example of custody transfer data — Before unloading

SHIP NAME
DATE
LOCAL TIME
PORT NAME
CARGO NO
CHIEF OFFICER

TRIM (m) 0,00 EVEN KEEL
LIST (DEGREE) 0,03 TO STARBOARD

LEVEL (m)	TANK 1	TANK 2	TANK 3	TANK 4
No.1	0,695	5,885	0,612	0,567
No.2	0,696	5,885	0,612	0,567
No.3	0,695	5,885	0,612	0,567
No.4	0,694	5,885	0,612	0,567
No.5	0,695	5,885	0,611	0,566
AVERAGE LEVEL (m)	0,695	5,885	0,612	0,567

TRIM CORRECTION (m)	0,000	0,000	0,000	0,000
LIST CORRECTION (m)	0,000	0,000	0,000	0,000
THERMAL CORRECTION (m)	-0,122	-0,128	-0,123	-0,123
CORRECTED LEVEL (m)	0,573	5,757	0,489	0,444
TANK VOLUME (m ³)	20,858	1 952,047	14,474	11,785
VOLUME SUMMED (m ³)	1 999,164	@ -160 °C		
THERMAL EXPANSION FACTOR	1,000 02	@ -159,2 °C		
CORRECTED LIQUID VOLUME (m ³)	1 999,204	@ -159,2 °C		

TEMPERATURE (°C)	TANK 1		TANK 2		TANK 3		TANK 4	
100 %	-61,44	V	-68,34	V	-64,00	V	-64,40	V
75 %	-103,82	V	-114,44	V	-104,33	V	-106,44	V
50 %	-151,60	V	-153,28	V	-151,38	V	-151,58	V
25 %	-157,69	V	-158,42	V	-157,88	V	-157,80	V
0 %	-159,12	L	-159,39	L	-159,01	L	-159,28	L

TANK AVG VAPOUR TEMP (°C)	-118,6	-123,6	-119,4	-120,1
SHIP'S AVG VAPOUR TEMP (°C)	-120,4			

TANK AVG LIQUID TEMP (°C)	-159,1	-159,4	-159,0	-159,3
SHIP'S AVG LIQUID TEMP (°C)	-159,2			

TANK VAPOUR PRESSURE (kPa(a))	111,1	110,7	111,1	111,1
SHIP'S AVG VAPOUR PRESSURE (kPa(a))	111,0			

COMPANY

NAME

SHIP'S MASTER _____
BUYER(S) _____
SELLER(S) _____
CARGO INSPECTOR _____

Figure D.3 — Example of custody transfer data — After unloading

SHIP NAME
PORT NAME
CARGO NO
CHIEF OFFICER

BEFORE UNLOADING

DATE

LOCAL TIME

TRIM (m)

LIST (DEGREE)

0,05
0,10

BY STERN
TO STARBOARD

AVERAGE LEVEL (m)

TRIM CORRECTION (m)

LIST CORRECTION (m)

THERMAL CORRECTION (m)

CORRECTED LEVEL (m)

TANK 1	TANK 2	TANK 3	TANK 4
37,332	37,051	37,487	37,391
0,000	0,000	0,000	0,000
-0,001	-0,001	-0,001	-0,001
-0,140	-0,141	-0,141	-0,141
37,191	36,909	37,345	37,249

TANK AVG VAPOUR TEMP (°C)

SHIP'S AVG VAPOUR TEMP (°C)

-132,0	-137,2	-134,7	-137,6
-135,4			

TANK AVG LIQUID TEMP (°C)

SHIP'S AVG LIQUID TEMP (°C)

-159,3	-159,2	-159,4	-158,7
-159,2			

TANK VAPOUR PRESS. (kPa(a))

SHIP'S AVG VAPOUR PRESS. (kPa(a))

112,2	111,9	112,2	112,2
112,1			

TANK VOLUME (m³)

VOLUME SUMMED (m³)

THERMAL EXPANSION FACTOR

CORRECTED LIQUID VOLUME (m³)

35 840,527	35 701,728	35 912,842	35 868,054
143 323,151	@ -160,0 °C		
1,000 02	@ -159,2 °C		
143 326,017	@ -159,2 °C (A)		

AFTER UNLOADING

DATE

LOCAL TIME

TRIM (m)

LIST (DEGREE)

0,00
0,03

EVEN KEEL
TO STARBOARD

AVERAGE LEVEL (m)

TRIM CORRECTION (m)

LIST CORRECTION (m)

THERMAL CORRECTION (m)

CORRECTED LEVEL (m)

TANK 1	TANK 2	TANK 3	TANK 4
0,695	5,885	0,612	0,567
0,000	0,000	0,000	0,000
0,000	0,000	0,000	0,000
-0,122	-0,128	-0,123	-0,123
0,573	5,757	0,489	0,444

TANK AVG VAPOUR TEMP (°C)

SHIP'S AVG VAPOUR TEMP (°C)

-118,6	-123,6	-119,4	-120,1
-120,4			

TANK AVG LIQUID TEMP (°C)

SHIP'S AVG LIQUID TEMP (°C)

-159,1	-159,4	-159,0	-159,3
-159,2			

TANK VAPOUR PRESS. (kPa(a))

SHIP'S AVG VAPOUR PRESS. (kPa(a))

111,1	110,7	111,1	111,1
111,0			

TANK VOLUME (m³)

VOLUME SUMMED (m³)

THERMAL EXPANSION FACTOR

CORRECTED LIQUID VOLUME (m³)

20,858	1 952,047	14,474	11,785
1 999,164	@ -160,0 °C		
1,000 02	@ -159,2 °C		
1 999,204	@ -159,2 °C (B)		

VOLUME UNLOADED (m³)

141 326,813	(A - B)	141 327	(A - B)
-------------	---------	---------	---------

COMPANY

NAME

SHIP'S MASTER

BUYER(S)

SELLER(S)

CARGO INSPECTOR

_____	_____
_____	_____
_____	_____
_____	_____

Figure D.4 — Example of certificate of unloading

D.2 Example of calculation of density

The density of LNG, loaded or discharged, shall be calculated in accordance with contractual requirements or if not otherwise specified, in accordance with industry methods, such as ISO 6578.^[2]

Densities based on assumed values from specific cargo sources (density libraries) should not be used for custody transfer quantity determination because of the possibility of potential contractual conflict and inaccuracy because of compositional changes during the LNG carrier journey.

In this example the density, ρ , of LNG is calculated using the revised Klosek-McKinley method.

$$\rho = \frac{\sum (x_i M_i)}{\sum (x_i V_i) - \left[k_1 + (k_2 - k_1) \times \frac{x_n}{0,0425} \right] \times x_m} \quad (\text{D.1})$$

where

- ρ is the density of liquid, expressed in kilograms per metre cubed (kg/m³);
- x_i is the mole fraction of component i determined by the analysis;
- x_m is the mole fraction of methane;
- x_n is the mole fraction of nitrogen;
- M_i is the molecular mass of component i , expressed in kilograms per kilomole;

NOTE 1 Values of M_i can be found in the following standards: ISO 6578,^[2] ISO 6976,^[4] GPA Standard 2145,^[11] and EI PMM Part III Section 1 (IP 251/76).^[9]

- V_i is the molar volume of component i , as liquid at temperature of T °C, expressed in cubic metres per kilomole;

NOTE 2 Molar volume is the volume of gas occupied by one mole under specific reference conditions of temperature and pressure. Values of V_i can be found in the following standards: ISO 6578,^[2] National Bureau of Standards NBSIR 77-867,^[14] and National Bureau of Standards Technical Note 1030.^[15]

k_1 and k_2 are the correction factors for volume reduction of liquid at temperature of T °C;

NOTE 3 Values of k_1 and k_2 can be found in the following standards: ISO 6578, National Bureau of Standards NBSIR 77-867,^[14] and National Bureau of Standards Technical Note 1030.^[15]

- T is the average temperature of the liquid in the ship's tanks after loading or before unloading.

Component	Mole fraction x_i	Molecular mass ^a M_i	$x_i M_i$	Molar volume ^a V_i	$x_i V_i$
CH ₄	0,900 0	16,042 6	14,438 340	0,038 259	0,034 433
C ₂ H ₆	0,049 0	30,069 4	1,473 401	0,048 010	0,002 352
C ₃ H ₈	0,029 0	44,096 2	1,278 790	0,062 570	0,001 815
<i>n</i> -C ₄ H ₁₀	0,013 0	58,123 0	0,755 599	0,076 952	0,001 000
<i>i</i> -C ₄ H ₁₀	0,004 0	58,123 0	0,232 492	0,078 433	0,000 314
<i>n</i> -C ₅ H ₁₂	0,001 0	72,149 8	0,072 150	0,091 667	0,000 092
N ₂	0,004 0	28,013 4	0,112 054	0,047 659	0,000 191
Total	1,000 0	—	18,362 826	—	0,040 197
^a cf. ISO 6578:1991.					

Given the values listed above and the following:

$$T = -159,2 \text{ } ^\circ\text{C}$$

$$k_1 = 0,000\ 483$$

$$k_2 = 0,000\ 778$$

$$x_m = 0,900\ 000 \text{ (Mol fraction of CH}_4\text{)}$$

$$x_n = 0,004\ 000 \text{ (Mol fraction of N}_2\text{)}$$

and inserting those values in Formula (D.1), the density of the LNG, ρ , is calculated as follows:

$$\rho = \frac{18,362\ 826}{0,040\ 197 - \left[0,000\ 483 + (0,000\ 778 - 0,000\ 483) \times \frac{0,004\ 0}{0,042\ 5} \right] \times 0,900}$$

$$\rho = 462,1 \text{ kg/m}^3$$

D.3 Example of calculation of heating value

The heating value is the amount of heat obtained by the complete combustion of a unit quantity of material. The gross, or higher, heating value is the amount of heat obtained where the water produced in the combustion is condensed and is the value normally used in LNG quantity determination.

The superior (gross or higher) heating value is as defined in ISO 6976 for the term superior calorific value.

The inferior (net or lower) heating value is as defined in ISO 6976 for the term inferior calorific value.

The heating value of LNG, loaded or discharged, shall be calculated in accordance with industry methods, such as GPA Standard 2172[12]/API MPMS Chapter 14.5,[7] GPA Standard 2145,[11] and ISO 6976,[4] or in accordance with contractual requirements based on compositional analyses, as described in ISO 6974 (all parts)[3] and GPA Standard 2261.[13]

ISO 6976, GPA Standard 2172/API MPMS Chapter 14.5 and GPA Standard 2145 do not give exactly the same outcome since some molar heating values differ. Therefore, it is recommended to consistently use either ISO or GPA standards or other contractual requirements, i.e. avoid mixing physical properties from ISO, GPA and/or other standards or reference documents.

When an online gas chromatograph is used, the data produced are normally used for the certificate of analysis and calculation of the heating value and density. The composite samplers are then used to produce the retained samples (available for buyer, seller and independent lab, in case of a dispute). Alternatively, the composite samples may be used for the determination of the heating value (and used as backup of the online gas chromatograph system).

The amount of total energy should be calculated under specific conditions (the reference condition, e.g. the reference pressure and temperature). The calculation should be as real gas or ideal gas according to contractual agreement. Standard conditions as defined in ISO 13443[5] are: calculation as real gas at 15 °C (288,15 K) and 101,325 kPa.

Physical properties used in these calculations shall be in accordance with industry standards, such as GPA Standard 2145 or contractual requirements.

Component	$x_i M_i$	Gross heating value on a mass basis ^a $H_{\text{mass},i}$	$\frac{H_{\text{mass},i} \cdot x_i M_i}{\sum (x_i M_i)}$
CH ₄	14,438 340	55,558	43,684 196
C ₂ H ₆	1,473 401	51,925	4,166 371
C ₃ H ₈	1,278 790	50,389	3,509 098
<i>n</i> -C ₄ H ₁₀	0,755 599	49,541	2,038 528
<i>i</i> -C ₄ H ₁₀	0,232 492	49,397	0,625 416
<i>n</i> -C ₅ H ₁₂	0,072 150	49,051	0,192 728
N ₂	0,112 054	0,000	0,000 000
Total	18,362 826	—	54,216 337
^a cf. ISO 6578:1991.			

Given the values listed above, the heating value of the LNG, H_{mass} , is 54,216 MJ/kg.

D.4 Example of calculation of energy of liquid

The energy of liquid, expressed in megajoules, can be calculated from Formulae (D.2) and (D.3).

$$E_L = V \times \rho \times H_{\text{mass}} \quad (\text{D.2})$$

and

$$H_{\text{mass}} = \frac{\sum (x_i M_i \times H_{\text{mass},i})}{\sum (x_i M_i)} \quad (\text{D.3})$$

where

E_L is the energy of liquid, expressed in megajoules;

V is the volume of liquid transferred to/from the ship, expressed in metres cubed (m³);

ρ is the density of liquid, expressed in kilograms per metre cubed (kg/m³);

H_{mass} is the gross (superior) heating value on a mass basis of the liquid, expressed in megajoules per kilograms;

$H_{\text{mass},i}$ is the gross (superior) heating value on a mass basis of the liquid, of component i , expressed in megajoules per kilogram.

NOTE Values of $H_{\text{mass},i}$ can be found in the following standards: ISO 6578,^[2] ISO 6976,^[4] GPA Standard 2145,^[11] and EI PMM Part III Section 1 (IP 251/76).^[9]

If

$$V = 141\,327 \text{ m}^3$$

$$\rho = 462,1 \text{ kg/m}^3$$

$$H_{\text{mass}} = 54,216 \text{ MJ/kg}$$

and these values are inserted into Formula (D.2), the energy of the liquid, E_L , is 3 540 695 518 MJ.

D.5 Example of calculation of energy of gas displaced

Any vapours returned to the LNG carrier's tanks to maintain proper tank pressure should be accounted for in accordance with contractual agreement.

When determining the energy of the returned vapour, E_D , it can be assumed that the gross heating value on a volumetric basis for the vapour mixture is that for pure methane at 101,325 kPa and 15 °C, if not determined by analysis, or such other value as defined by contractual agreement.

The energy of the gas displaced can be calculated using Formula (D.4):

$$E_D = V \times \left(\frac{273,15 + T_S}{273,15 + T_{\text{vap}}} \right) \times \frac{P_{\text{vap}}}{P_S} \times H_{\text{vol}} \quad (\text{D.4})$$

where

E_D is the energy of gas displaced, expressed in megajoules;

V is the volume of liquid transferred to/from the ship, expressed in metres cubed (m^3);

T_S is the reference temperature, typically standard temperature, i.e. 15 °C;

T_{vap} is the average temperature of the vapour in the ship's tanks before loading or after unloading, expressed in degrees Celsius;

P_{vap} is the average pressure of the vapour in the ship's tanks before loading or after unloading, expressed in kilopascals absolute;

P_S is the reference pressure, typically standard pressure, i.e. 101,325 kPa;

H_{vol} is the gross (superior) heating value of methane on a volume basis of the vapour at T_S and P_S , expressed in megajoules per metres cubed (MJ/m^3).

NOTE Values of H_{vol} can be found in the following standards: ISO 6578,^[2] ISO 6976,^[4] and EI PMM Part III Section 1 (IP 251/76).^[9]

If

$$V = 141\,327 \text{ m}^3$$

$$T_{\text{vap}} = -120,4 \text{ °C}$$

$$P_{\text{vap}} = 111,0 \text{ kPa}$$

$$T_S = 15 \text{ °C (cf. ISO 6578:1991)}$$

$$P_S = 101,325 \text{ kPa (cf. ISO 6578:1991)}$$

$$H_{\text{vol}} = 37,696 \text{ MJ/m}^3 \text{ (cf. ISO 6578:1991)}$$

and these values are inserted into Formula (D.4), the energy of the gas displaced, E_D , is 11 009 413 MJ.

D.6 Example of calculation of energy transferred

The energy of LNG transferred can be calculated using Formula (D.5):

$$E = \frac{1}{k} \times (E_L - E_D \pm E_E) \quad (\text{D.5})$$

where

E is the energy transferred, expressed in MMBtu;

E_L is the energy of liquid, expressed in megajoules;

E_D is the energy of gas displaced, expressed in megajoules;

E_E is the energy of gas consumed by the engine room (normally zero during cargo transfer), expressed in megajoules, where + is for an LNG load and – is for an LNG discharge (see the *GIIGNL LNG Custody Transfer Handbook*^[10]);

$1/k$ is the factor to convert energy in megajoules to energy in MMBtu, $k = 1\,055,12$ where 60 °F is the reference temperature for the MMBtu value and 15 °C is the reference temperature for MJ. $k = 1055,056$ where the reference temperature for MJ and MMBtu is 15 °C .

If

$$E_L = 3\,540\,695\,518\text{ MJ}$$

$$E_D = 11\,009\,413\text{ MJ}$$

and these values are inserted into Formula (D.5), the energy transferred, E , is calculated as follows:

$$E = \frac{1}{1\,055,12} \times (E_L - E_D)$$

$$E = 3\,345\,294\text{ MMBtu}$$

Annex E (informative)

Sampling

E.1 General

Although sampling for analysis is indispensable as part of the LNG custody transfer process, in general, sampling systems for this purpose are not located on board LNG carriers. Customarily, the representative sample of the LNG shipment is obtained from the onshore pipeline during loading or discharge.

Where the intermittent method of sampling is applied, analysis is implemented either by online analysis or offline analysis.

Both the continuous and intermittent methods are widely applied.

Analysis with an online gas chromatograph is, by definition, intermittent, as is spot sampling. Online gas chromatographs have a cycle time typically between 3 min and 8 min. These data are normally used for calculation of the overall composition, density and heating value.

The custody transfer process involves the calculation of a delivered energy value from measured volumes and composition, which depends on sampling representativity and the accuracy of gas chromatography.

ISO 8943 provides additional details of LNG sampling equipment and procedures.

E.2 LNG sampling basic principles

A sample of LNG is withdrawn from the main loading or unloading line on shore. The LNG sample is fed to a vaporizer and a liquid to gas change of state is achieved. It is critical that this change of state be complete and controlled. The vaporized LNG typically sample passes to either

- a) a gas sample holder and then to sample cylinders in the case of continuous sampling for analysis by gas chromatograph,
- b) a small accumulator and then to a sample container in the case of spot sampling, or
- c) an online gas chromatograph in the case of intermittent sampling.

Spot samples are most often drawn with the intention of being used as a backup in case there is a failure in the main sampling system and to verify results from the online gas chromatograph. Spot samples are often used in correlation studies. There are occasions where these spot samples are used for custody transfer purposes.

Sample representativeness shall be preserved at each stage:

- LNG sample off take to vaporizer;
- vaporizer to accumulator;
- accumulator to spot sample collection point;
- accumulator to online gas chromatograph;
- accumulator to sample container.

E.3 Sampling period

It is recommended that the LNG be sampled once the LNG transfer flow rate is sufficiently settled. It is necessary to exclude the initial period, corresponding to the starting of transfer pumps and increase of LNG flow rate, until the main pipe is completely full of LNG and single-phase liquid such as where the full flow rate is obtained.

It is also necessary to exclude the final period where LNG flow rate decreases before stopping.

When significant changes in pressure or flow rate occur in the transfer line, it is better to suspend sampling temporarily.

Irrespective of the sampling methods, the sampling period shall be only that period of time during which the flow rate has been sufficiently stabilized, thus excluding the initial ramp-up in the flow rate and the ramp-down before stopping the pumps. Sampling shall be suspended if the (un)loading operation is interrupted.

E.4 Sampling frequency

As far as filling of a gas holder is concerned, sampling is continuous during the sampling period, at a fixed flow rate; spot samples can be collected, in addition, during this operation in order to control LNG quality and to monitor the transfer operation, but the corresponding analyses are not to be used for energy calculation.

When gas samples are taken in sample containers during LNG transfer, it should be done on a regular basis, depending on the characteristics of transfer lines and equipment, the organization of operation in the plant, the duration of gas sample analysis, etc.

For example, sampling frequency is often around 1 h, which totals approximately eight samples for a normal LNG transfer duration of 12 h, with sampling starting approximately 2 h after the beginning of transfer and ending approximately 2 h before the end of transfer.

When vaporized LNG is sent directly to an online gas chromatograph for analysis, the gas sample analysis frequency depends on the chromatograph used. For example, one chromatographic analysis occurs every 3 min to 8 min during the sampling period if a chromatograph is dedicated for such an operation and if components higher than C₆ are not separated.

E.5 Purging

It is recommended that purging of sampling devices (probe, line, vaporizer, gas holder) and sample conditioning equipment (line, sample containers) be carried out before any LNG or gas sample is taken.

If samples are taken periodically in sample containers, it is better to keep the sampling system in service between operations so that the equipment is continuously purged and ready for sampling with the same operating parameters.

E.6 Sampling parameters

It is important that the operating parameters of the sampling device (pressure, temperatures and flow rates) be kept as constant as possible throughout the sampling period, in order to obtain a smooth operation, which enables representative and repeatable sampling.

E.7 Utilization of sample containers

Gas samples collected in sample containers are:

- on the one hand, directly analysed in order to determine the average composition of LNG transferred, and

- on the other hand, possibly given to the other party concerned with the transfer (purchaser or seller according to the type of gas purchase contract) or even kept for further investigations, in case of dispute for instance, during a period defined in the contract (e.g. several weeks).

When the sampling device includes a line whereby the vaporized LNG is directly piped to the gas chromatograph, an additional system may be designed to collect spot samples (sample container filling station), which are then only used for control, these samples being taken on a diversion pipe at the outlet of the vaporizer with the sampling parameters being adjusted accordingly.

E.8 Purpose of analysis

Analysis of LNG samples is implemented for the following purposes:

- a) determination of density and heating value by calculation;
- b) confirmation that component concentrations are within ranges allowed by the SPA;
- c) detection of trace components, if any, which are not in compliance with the SPA.

E.9 Continuous sampling method

In this sampling method, gas from the LNG sample vaporizer is continuously transferred to the gas sample holder during the sampling period. Then, it is fed into the sample containers as the representative sample of the shipment and subjected to analysis using gas chromatography in the laboratory. Two types of gas sample holders are commonly used; one is the “water-seal-type” and the other is the “waterless-type”. After completion of the sampling, the gas in the gas holder is homogenized, compressed and fed into three (typically) identical sample cylinders. In this way, composite samples are prepared.

In the case of the water-seal-type gas sample holder, the sample gas inside the inner tank may be completely discharged by submerging the inner tank into the seal water. In addition, seal water may be subjected to bubbling in order to prevent contamination of the sample by atmospheric gases dissolved in the water.

In the case of the waterless-type gas sample holder, discharging of any residual gas of the last shipment should readily be carried out.

E.10 Intermittent sampling method

E.10.1 For online analysis

LNG vapour from the sample vaporizer is fed to the online gas chromatograph directly for immediate analysis without the use of the gas sample holder. The gas sample obtained simultaneously with analysis is charged into the sample containers for retention for future reference. Sampling intervals and the number of gas chromatographic analyses should be in accordance with the SPA.

E.10.2 For off-line analysis

LNG vapour from the sample vaporizer is charged into the gas sample containers (a fixed volume or floating-piston cylinder) for analysis by gas chromatography in the laboratory. At the same time, it is charged into the sample containers for retention for future reference. As with the continuous sampling method, a number of identical containers (typically three) are filled with a sample to represent the composite of the stream. Sampling intervals should be in accordance with the SPA.

E.11 Spot sampling method

This is a sampling process involving the taking of a spot sample at various times throughout the cargo transfer process. This can consist, for example, of samples taken whenever 25 %, 50 % and 75 % of the

cargo has been transferred. Although this method can be valuable to provide a backup sample in the case other sampling methods fail, it is not recommended as the means of providing the custody transfer sample.

E.12 Preparation of the sample containers

Sample containers which appear to be damaged shall not be used. In addition, any remnant of the last sample which can remain in the sample containers as well as in the sampling line shall be purged in accordance with the procedures agreed upon by the parties.

E.13 Sampling operation

Sampling operations shall be performed by trained and experienced staff complying with relevant safety regulations and procedures. The sample containers shall not be filled in excess of their maximum fill pressure.

E.14 Retention of the representative sample

The sample container(s) filled with the representative sample shall be subjected to a leak test and retained at the terminal for the period agreed in the SPA. The top and bottom valves shall be sealed. The sample shall be labelled noting identification details, such as the date and time of sampling, vessel name, sampling method, sample container number and operator.

Annex F (informative)

Marine measurement witnessing checklists

VESSEL NAME: _____ DATE: _____
 LOAD/DISCHARGE: _____ VOYAGE No.: _____
 TERMINAL NAME: _____ REFERENCE No.: _____
 CARGO INSPECTOR: _____

If an item listed below is completed in accordance with the procedures, check “yes”; if it is not, check “no” and explain under the comment section. Check “N/A” if an item is not applicable.

The following information should be obtained during the key meeting prior to cargo loading or discharge operations.

Item		Yes	No	N/A	Comments
1	Vessel particulars				
1A	Flag				
1B	Classification society				
1C	Total cargo tank capacity (m ³)				
1D	Cargo tank design (check one):				
	Spherical				
	Membrane				
	SPB				
	Other (indicate type)				
1E	Number of cargo tanks				
1F	Most recent dry-dock date				
1G	Most recent gas-free date				
1H	CTMS certified by/date				
1I	Tank capacity table certified by/ date				
1J	Cool-down table certified by/ date				
1K	Level gauge certified by/ date				
1L	Temperature gauge certified by/ date				
1M	Pressure gauge certified by/ date				
1N	Calibration method and standard used for tank capacity table(s)				
1O	Designated primary level gauge				

Item		Yes	No	N/A	Comments
1P	Date of primary level gauge calibration Date of primary level gauge verification				
1Q	Primary temperature device type and number of sensors				
1R	Date of primary temperature calibration Date of primary temperature verification				
1S	Pressure equipment type				
1T	Date of pressure calibration Date of pressure verification				
1U	Designated secondary level gauge				
1V	Date of secondary level gauge calibration Date of secondary level gauge verification				
1W	Secondary temperature device type and number of sensors				
1X	Liquefaction capability on board				
2	Prior to transfer				
2A	Are lines prepared?				
	Purged?				
	Cooled down?				
	Liquid-filled?				
2B	Quantity to be loaded/discharged (including appropriate min./max. and stops)				
2C	Source of custody transfer sample(s)				
2D	Gas chromatograph number and type				
2E	Gas chromatograph verified/calibrated				
2F	Sampling plan, primary and backup				
2G	Number of samples				
2H	Size of samples				
2I	Source of samples				
2J	Sample analysis and test requirements				
2K	Liquid nitrogen tanks gauged before and after movement				
2L	Boil-off gas isolated from engine room during cargo transfer?				
2M	Cargo tank gas up required?				
2N	Cargo tank cool down required?				
2O	Any necessary stop gauges set and confirmed with terminal personnel				
2P	Composition, density and molecular mass (weight) for cargo provided				
3	Opening survey				
3A	Vessel trim and list recorded				
3B	Opening calculations made prior to transfer				

Item		Yes	No	N/A	Comments
3C	Have float gauges reached temperature equilibrium?				
3D	Cargo tanks and systems static				
3E	Gas valve closed to the engine room prior to gauging				
3F	Vapour manifold closed prior to gauging				
3G	Primary and secondary levels recorded (level, temperature and pressure)				
3H	Status of vessel lines and piping during gauging – full/empty				
3I	Opening calculations made prior to transfer				
4	During cargo loading/discharge operations				
4A	Was the transfer continuous throughout and properly recorded?				
4B	Was the cargo transferred at the contractually agreed temperature and rate?				
4C	Vapour returned from shore to ship				
4D	Vessel vent used at any time				
4E	Any other incidents noted that can have affected measurement accuracy				
5	Closing vessel measurements				
5A	Status of vessel lines and piping during gauging – full/empty				
5B	Vessel lines and piping in same condition as prior to transfer				
5C	Vessel trim and list recorded				
5D	Stop gauges met within contractual limits				
5E	Final calculations made on completion of transfer				
6	Post-transfer				
6A	Any incident(s) or occurrence(s) noted that can have affected measurement accuracy				
6B	Was a letter of protest or notice of apparent discrepancy issued?				

Bibliography

- [1] ISO 4266-5, *Petroleum and liquid petroleum products — Measurement of level and temperature in storage tanks by automatic methods — Part 5: Measurement of temperature in marine vessels*
 - [2] ISO 6578, *Refrigerated hydrocarbon liquids — Static measurement — Calculation procedure*
 - [3] ISO 6974 (all parts), *Natural gas — Determination of composition and associated uncertainty by gas chromatography*
 - [4] ISO 6976¹⁾, *Natural gas — Calculation of calorific value, density, relative density and Wobbe index from composition*
 - [5] ISO 13443, *Natural gas — Standard reference conditions*
 - [6] ISO 28460, *Petroleum and natural gas industries — Installation and equipment for liquefied natural gas — Ship-to-shore interface and port operations*
 - [7] API MPMS Chapter 14.5, *Calculation of Gross Heating Value, Relative Density, Compressibility and Theoretical Hydrocarbon Liquid Content for Natural Gas Mixtures for Custody Transfer*
 - [8] API MPMS Chapter 17.1, *Guidelines for Marine Cargo Inspection*
 - [9] Energy Institute (EI) (formerly the Institute of Petroleum), *Petroleum Measurement Manual (PMM), Part III Static Measurement of Refrigerated Hydrocarbon Liquids, Section 1 Calculation Procedures*, IP 251/76
 - [10] *GIIGNL LNG Custody Transfer Handbook*. Third Edition, 2010
 - [11] GPA Standard 2145, *Table of Physical Constants for Hydrocarbons and Other Compounds of Interest to the Natural Gas Industry*
 - [12] GPA Standard 2172, *Calculation of Gross Heating Value, Relative Density, Compressibility and Theoretical Hydrocarbon Liquid Content for Natural Gas Mixtures for Custody Transfer*
 - [13] GPA Standard 2261, *Analysis for Natural Gas & Similar Gaseous Mixtures by Gas Chromatography*
 - [14] United States National Bureau of Standards NBSIR 77-867, *A comparison of mathematical models for the prediction of LNG densities*
 - [15] United States National Bureau of Standards (NBS) Technical Note 1030 December 1980, *Four mathematical models for the prediction of LNG densities*
 - [16] API Standard 2217A, *Guidelines for Work in Inert Confined Spaces in the Petroleum and Petrochemical Industries*
 - [17] ICS Tanker Safety Guide — Liquefied Gas
 - [18] ICS/OCIMF/IAPH International Safety Guide for Oil Tankers and Terminals (ISGOTT)
 - [19] IMO International Code for the Construction and Equipment of Ships Carrying Liquefied Gases in Bulk (IGC Code)
- NOTE Earlier versions of the gas codes can apply to older ships (see the note to [3.1.13](#)).
- [20] *SIGTTO Liquefied Gas Handling Principles on Ships and in Terminals*
 - [21] *SIGTTO Liquefied Gas Fire Hazard Management*

1) To be published.

British Standards Institution (BSI)

BSI is the national body responsible for preparing British Standards and other standards-related publications, information and services.

BSI is incorporated by Royal Charter. British Standards and other standardization products are published by BSI Standards Limited.

About us

We bring together business, industry, government, consumers, innovators and others to shape their combined experience and expertise into standards-based solutions.

The knowledge embodied in our standards has been carefully assembled in a dependable format and refined through our open consultation process. Organizations of all sizes and across all sectors choose standards to help them achieve their goals.

Information on standards

We can provide you with the knowledge that your organization needs to succeed. Find out more about British Standards by visiting our website at bsigroup.com/standards or contacting our Customer Services team or Knowledge Centre.

Buying standards

You can buy and download PDF versions of BSI publications, including British and adopted European and international standards, through our website at bsigroup.com/shop, where hard copies can also be purchased.

If you need international and foreign standards from other Standards Development Organizations, hard copies can be ordered from our Customer Services team.

Subscriptions

Our range of subscription services are designed to make using standards easier for you. For further information on our subscription products go to bsigroup.com/subscriptions.

With **British Standards Online (BSOL)** you'll have instant access to over 55,000 British and adopted European and international standards from your desktop. It's available 24/7 and is refreshed daily so you'll always be up to date.

You can keep in touch with standards developments and receive substantial discounts on the purchase price of standards, both in single copy and subscription format, by becoming a **BSI Subscribing Member**.

PLUS is an updating service exclusive to BSI Subscribing Members. You will automatically receive the latest hard copy of your standards when they're revised or replaced.

To find out more about becoming a BSI Subscribing Member and the benefits of membership, please visit bsigroup.com/shop.

With a **Multi-User Network Licence (MUNL)** you are able to host standards publications on your intranet. Licences can cover as few or as many users as you wish. With updates supplied as soon as they're available, you can be sure your documentation is current. For further information, email bsmusales@bsigroup.com.

BSI Group Headquarters

389 Chiswick High Road London W4 4AL UK

Revisions

Our British Standards and other publications are updated by amendment or revision.

We continually improve the quality of our products and services to benefit your business. If you find an inaccuracy or ambiguity within a British Standard or other BSI publication please inform the Knowledge Centre.

Copyright

All the data, software and documentation set out in all British Standards and other BSI publications are the property of and copyrighted by BSI, or some person or entity that owns copyright in the information used (such as the international standardization bodies) and has formally licensed such information to BSI for commercial publication and use. Except as permitted under the Copyright, Designs and Patents Act 1988 no extract may be reproduced, stored in a retrieval system or transmitted in any form or by any means – electronic, photocopying, recording or otherwise – without prior written permission from BSI. Details and advice can be obtained from the Copyright & Licensing Department.

Useful Contacts:

Customer Services

Tel: +44 845 086 9001

Email (orders): orders@bsigroup.com

Email (enquiries): cservices@bsigroup.com

Subscriptions

Tel: +44 845 086 9001

Email: subscriptions@bsigroup.com

Knowledge Centre

Tel: +44 20 8996 7004

Email: knowledgecentre@bsigroup.com

Copyright & Licensing

Tel: +44 20 8996 7070

Email: copyright@bsigroup.com



...making excellence a habit.™