



BSI Standards Publication

Rough-terrain trucks — Safety requirements and verification

Part 4: Additional requirements for variable-reach trucks handling freely suspended loads

National foreword

This British Standard is the UK implementation of ISO 10896-4:2015.

The UK participation in its preparation was entrusted to Technical Committee MHE/7, Industrial trucks.

A list of organizations represented on this committee can be obtained on request to its secretary.

This publication does not purport to include all the necessary provisions of a contract. Users are responsible for its correct application.

© The British Standards Institution 2015.
Published by BSI Standards Limited 2015

ISBN 978 0 580 78923 6

ICS 53.060

Compliance with a British Standard cannot confer immunity from legal obligations.

This British Standard was published under the authority of the Standards Policy and Strategy Committee on 30 November 2015.

Amendments/corrigenda issued since publication

Date	Text affected
------	---------------

INTERNATIONAL
STANDARD

ISO
10896-4

First edition
2015-11-01

**Rough-terrain trucks — Safety
requirements and verification —**

Part 4:
**Additional requirements for
variable-reach trucks handling freely
suspended loads**

Chariots tout-terrain — Exigences de sécurité et vérification —

*Partie 4: Exigences additionnelles pour chariots à portée variable
manipulant des charges suspendues à oscillation libre*



Reference number
ISO 10896-4:2015(E)

© ISO 2015



COPYRIGHT PROTECTED DOCUMENT

© ISO 2015, Published in Switzerland

All rights reserved. Unless otherwise specified, no part of this publication may be reproduced or utilized otherwise in any form or by any means, electronic or mechanical, including photocopying, or posting on the internet or an intranet, without prior written permission. Permission can be requested from either ISO at the address below or ISO's member body in the country of the requester.

ISO copyright office
Ch. de Blandonnet 8 • CP 401
CH-1214 Vernier, Geneva, Switzerland
Tel. +41 22 749 01 11
Fax +41 22 749 09 47
copyright@iso.org
www.iso.org

Contents

Page

Foreword	iv
Introduction	v
1 Scope	1
2 Normative references	1
3 Terms and definitions	2
4 Safety requirements and/or protective measures	3
4.1 General requirements.....	3
4.2 Mounting and fixing.....	3
4.3 Design and strength.....	4
4.3.1 Lifting attachment.....	4
4.3.2 Wire rope hoist attachments.....	4
4.4 Stability.....	5
4.4.1 Load chart for suspended load lifting attachment(s).....	5
5 Verification of the safety requirements and/or protective measures	5
5.1 General.....	5
5.2 Tests for trucks fitted with lifting attachments.....	5
5.3 Static strength test.....	5
5.3.1 General.....	5
5.3.2 Test procedure.....	5
5.3.3 Verification.....	5
5.4 Dynamic structural tests.....	5
5.4.1 General.....	5
5.4.2 General test set up.....	5
5.4.3 Test procedure.....	6
5.4.4 Verification.....	6
5.5 Additional requirements for pick and carry.....	7
5.5.1 General.....	7
5.5.2 Stability by test loading.....	7
5.5.3 Requirements.....	7
6 Information for use	7
6.1 Content requirements.....	7
Bibliography	9

Foreword

ISO (the International Organization for Standardization) is a worldwide federation of national standards bodies (ISO member bodies). The work of preparing International Standards is normally carried out through ISO technical committees. Each member body interested in a subject for which a technical committee has been established has the right to be represented on that committee. International organizations, governmental and non-governmental, in liaison with ISO, also take part in the work. ISO collaborates closely with the International Electrotechnical Commission (IEC) on all matters of electrotechnical standardization.

The procedures used to develop this document and those intended for its further maintenance are described in the ISO/IEC Directives, Part 1. In particular the different approval criteria needed for the different types of ISO documents should be noted. This document was drafted in accordance with the editorial rules of the ISO/IEC Directives, Part 2 (see www.iso.org/directives).

Attention is drawn to the possibility that some of the elements of this document may be the subject of patent rights. ISO shall not be held responsible for identifying any or all such patent rights. Details of any patent rights identified during the development of the document will be in the Introduction and/or on the ISO list of patent declarations received (see www.iso.org/patents).

Any trade name used in this document is information given for the convenience of users and does not constitute an endorsement.

For an explanation on the meaning of ISO specific terms and expressions related to conformity assessment, as well as information about ISO's adherence to the WTO principles in the Technical Barriers to Trade (TBT) see the following URL: [Foreword - Supplementary information](#)

The committee responsible for this document is ISO/TC 110, *Industrial trucks*, Subcommittee SC 4, *Rough-terrain trucks*.

ISO 10896 consists of the following parts, under the general title *Rough-terrain trucks — Safety requirements and verification*:

- *Part 1: Variable-reach trucks*
- *Part 2: Slewing trucks*
- *Part 4: Additional requirements for variable-reach trucks handling freely suspended loads*
- *Part 5: Interface between rough-terrain truck and integrated personnel work platform*
- *Part 6: Tilting operator's cabs*

The following part is under preparation:

- *Part 7: Longitudinal load moment systems*

Additional user requirements for variable-reach trucks handling freely suspended loads are given in ISO 11525-4.

Introduction

This International Standard is one of a set of standards produced by ISO/TC 110/SC 4 as part of its program of work regarding standardization of terminology, general safety, performance and user requirements for rough-terrain trucks (hereafter also referred to as trucks).

This document is a type C standard as stated in ISO 12100.

This document is of relevance, in particular, for the following stakeholder groups representing the market players with regard to machinery safety:

- machine manufacturers (small, medium and large enterprises);
- health and safety bodies (regulators, accident prevention organisations, market surveillance, etc.).

Others can be affected by the level of machinery safety achieved with the means of the document by the above-mentioned stakeholder groups:

- machine users/employers (small, medium and large enterprises);
- machine users/employees (e.g. trade unions, organizations for people with special needs);
- service providers, e.g. for maintenance (small, medium and large enterprises);
- consumers (in the case of machinery intended for use by consumers)

The above-mentioned stakeholder groups have been given the possibility to participate at the drafting process of this document.

The machinery and systems concerned and the extent to which hazards, hazardous situations or hazardous events are covered are indicated in the scope of this document.

When requirements of this type-C standard are different from those which are stated in type-A or type-B standards, the requirements of this type-C standard take precedence over the requirements of the other standards for machines that have been designed and built according to the requirements of this type-C standard.

Rough-terrain trucks — Safety requirements and verification —

Part 4: Additional requirements for variable-reach trucks handling freely suspended loads

1 Scope

This part of ISO 10896 specifies the additional safety requirements and means of verification for rough-terrain variable-reach trucks (hereafter referred to as trucks) fitted with a lifting attachment for handling suspended loads which can swing freely in one or more directions. It is applicable to trucks covered by ISO 10896-1 and ISO 10896-2.

This part of ISO 10896 does not apply to:

- the lifting of suspended loads which by design of the load or the lifting attachments does not allow the load to swing freely in any direction;
- the handling of flexible intermediate bulk containers, as defined in ISO 21898, carried under the forks of the truck;
- any attachments/means used for lifting personnel;
- lifting accessories not included as part of the lifting attachment;
- freight container handling trucks.

This part of ISO 10896 deals with significant hazards, hazardous situations or hazardous events relevant to trucks handling a freely suspended load, when they are used as intended by the manufacturer.

This part of ISO 10896 is not applicable to rough-terrain variable-reach trucks fitted with a lifting attachment for handling suspended loads manufactured before the date of its publication.

2 Normative references

The following documents, in whole or in part, are normatively referenced in this document and are indispensable for its application. For dated references, only the edition cited applies. For undated references, the latest edition of the referenced document (including any amendments) applies.

ISO 7000:2014, *Graphical symbols for use on equipment — Registered symbols*

ISO 10896-1:2012, *Rough-terrain trucks — Safety requirements and verification — Part 1: Variable-reach trucks*

ISO 10896-2:—¹⁾, *Rough-terrain trucks — Safety requirements and verification — Part 2: Slewing variable-reach trucks*

ISO 12100:2010, *Safety of machinery — General principles for design — Risk assessment and risk reduction*

ISO 22915-10, *Industrial trucks — Verification of stability — Part 10: Additional stability test for trucks operating in the special condition of stacking with load laterally displaced by powered devices*

1) To be published.

ISO 22915-14, *Industrial trucks — Verification of stability — Part 14: Rough-terrain variable-reach trucks*

ISO 22915-20, *Industrial trucks — Verification of stability — Part 20: Additional stability test for trucks operating in the special condition of offset load, offset by utilization*

ISO 22915-24, *Industrial trucks — Verification of stability — Part 24: Slewing variable-reach rough-terrain trucks*

3 Terms and definitions

For the purpose of this document, the terms and definitions given in ISO 12100, ISO 10896-1, ISO 10896-2 and the following apply.

3.1 lifting attachment

device mounted to the truck from which a lifting accessory or a load can be suspended

EXAMPLE Jib, hoist.

3.2 lifting accessory

component or device fitted to the lifting attachment (e.g. sling), placed between the lifting attachment and the load

3.3 jib

device, telescopic or not, intended to extend forward the lifting point of the truck

Note 1 to entry: See Figure 1.

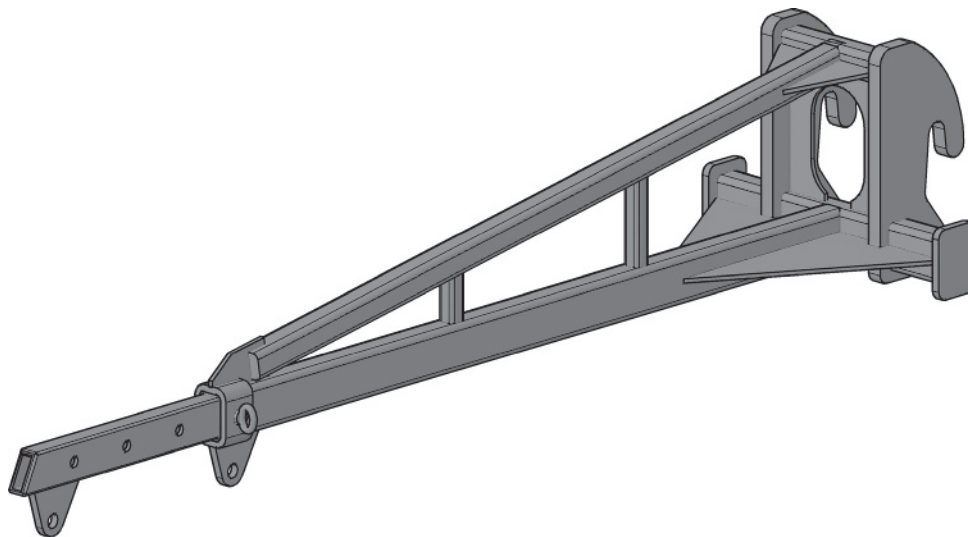

Figure 1 — Example of jib

3.4 hoist

device for lifting and lowering suspended loads over predetermined distances, using ropes or chains

3.5 suspended load

load that can swing freely when attached to a lifting attachment by means of a lifting accessory or a load handling mean (e.g. log clamp)

3.6

tether

means used to restrain the dynamic effects of the load

3.7

tag line

rope which can be fastened to a suspended load to restrain spinning or swinging of the load

3.9

level ground

ground with a gradient of $0 \pm 2 \%$

3.10

pick and carry

act of travelling with a suspended load

3.11

slinger/rigger

personnel other than the operator driving the truck, who is in charge of attaching the load to the lifting accessory (slinging) and the lifting accessory to the lifting attachment

3.12

rotation-resistant rope

stranded rope designed to generate reduced levels of torque and rotation when loaded

[SOURCE: ISO 17893:2004, 2.6.1.3]

3.13

load handling means

part of the lifting attachment for holding the load or which the load/lifting accessory is attached to

EXAMPLE Hook, grab, clamp, etc.

4 Safety requirements and/or protective measures

4.1 General requirements

Trucks shall comply with the safety requirements and/or protective/risk reduction measures of this clause.

In addition, the truck shall be designed according to the principles of ISO 12100:2010 for relevant but not significant hazards which are not dealt with by this document.

Any lifting attachment mounted to the truck intended to handle a suspended load shall comply with ISO 10896-1:2012, Annex B or ISO 10896-2:—²⁾, Annex B, and the requirements of this part of ISO 10896.

4.2 Mounting and fixing

The lifting attachment shall be designed:

- to minimize hazards for the slinger/rigger and/or bystander (e.g. pipes and hoses containing fluid under pressure $> 5 \text{ MPa}$ (50 bar) and/or at temperature $> 50^\circ\text{C}$);
- to facilitate attachment and intentional detachment;
- so that there is no restriction (e.g. snagging) during normal operation of the truck or when hoisting.

The fixing position of the lifting accessory(ies) on the lifting attachment shall be such that it is not deflected from its vertical path or damaged by other truck parts or part of the lifting attachment.

2) To be published.

4.3 Design and strength

4.3.1 Lifting attachment

All load handling means (e.g. hooks, magnets, grabs, etc.) approved by the truck manufacturer for a specific truck model and fitted to a lifting attachment shall have at least the same rated capacity of the lifting attachment itself.

The lifting attachment(s) shall be designed to withstand, as a minimum, a static load of 2,5 times the rated capacity of the attachment without permanent deformation or release of the load.

This shall be proven by calculation and/or by tests with a test load of 2,5 times the rated capacity of the attachment.

4.3.2 Wire rope hoist attachments

4.3.2.1 General

Hooks fitted to a hoist shall be determined by the size and the type of rope to allow the same rated capacity as the hoist.

The wire rope shall remain taut on the drum even when the boom of the truck is lowered and the load is on the ground such that the rope becomes slack.

Means shall be provided to prevent the wire rope jumping off the sheaves even when the rope becomes slack.

4.3.2.2 Wire ropes

When a hoist is selected, wire ropes shall have a factor $K_2 \geq 3,55$, except rotation-resistant ropes that shall have a factor $K_2 \geq 4,5$.

NOTE 1 ISO 16625 can be used as guidance.

$$K_2 = \frac{L_{wr} \times n}{RCA + D_w}$$

where:

L_{wr} is the minimum breaking strength for new wire rope;

n is the number of wire ropes;

RCA is the rated capacity of the attachment;

D_w is the dead weight of the lifting accessory carried by the wire rope(s).

NOTE 2 The minimum breaking strength for a new wire rope is a certified value given by its manufacturer.

Pulley diameters shall follow the wire rope manufacturer's recommendations.

4.3.2.3 Wire rope terminations

The ratio between the maximum strength of wire rope/rope end combination and the rated capacity of the lifting attachment (RCA) shall be at least 5.

4.4 Stability

4.4.1 Load chart for suspended load lifting attachment(s)

For each lifting attachment, the load chart for suspended loads shall be provided and, where applicable, determined according to ISO 22915-10, ISO 22915-14, ISO 22915-20 and ISO 22915-24 and [Clause 5.5.1](#).

5 Verification of the safety requirements and/or protective measures

5.1 General

A representative of each model of serial production truck, fitted with a representative of each lifting attachment model, shall be verified by testing. The test results shall be used to validate the load chart(s).

5.2 Tests for trucks fitted with lifting attachments

- a) static strength test according to [5.3](#); and
- b) dynamic structural test according to [5.4](#); and
- c) travelling / pick and carry test according to [5.5](#).

5.3 Static strength test

5.3.1 General

The purpose of this test is to demonstrate the overall structural integrity of the truck fitted with a specified lifting attachment.

5.3.2 Test procedure

Trucks fitted with a specified lifting attachment shall be tested at 125 % of the rated capacity of the truck fitted with the lifting attachment under the least favourable position(s) of the boom and attachment, according to the lifting attachment load chart, on level ground.

This test shall be performed both on wheels and stabilizers, if provided.

5.3.3 Verification

The truck fitted with a specified lifting attachment shall be considered as complying with this test provided that the test load is safely supported for 10 min without permanent deformation or component failure affecting any part of the truck and the specified lifting attachment.

5.4 Dynamic structural tests

5.4.1 General

The purpose of this test is to demonstrate the overall structural integrity of the truck fitted with a specified lifting attachment in dynamic conditions.

5.4.2 General test set up

Trucks being on firm level ground and fitted with a specified lifting attachment shall be tested at least with:

- a) a load of 100 % of the rated capacity of the truck fitted with the attachment;

b) the load at the maximum reach according to the load chart.

For attachments like jibs, the jib position shall be horizontal and parallel to the ground.

The standard test load shall be a cube with a length of L_b , suspended by lifting accessories like chains, ropes, slings, etc. such that the load position A is as in [Figure 2](#), where:

- $1\ 000\ \text{mm} \leq L_b \leq 1\ 300\ \text{mm}$;
- $500\ \text{mm} \leq L_{acc} \leq 1\ 000\ \text{mm}$.

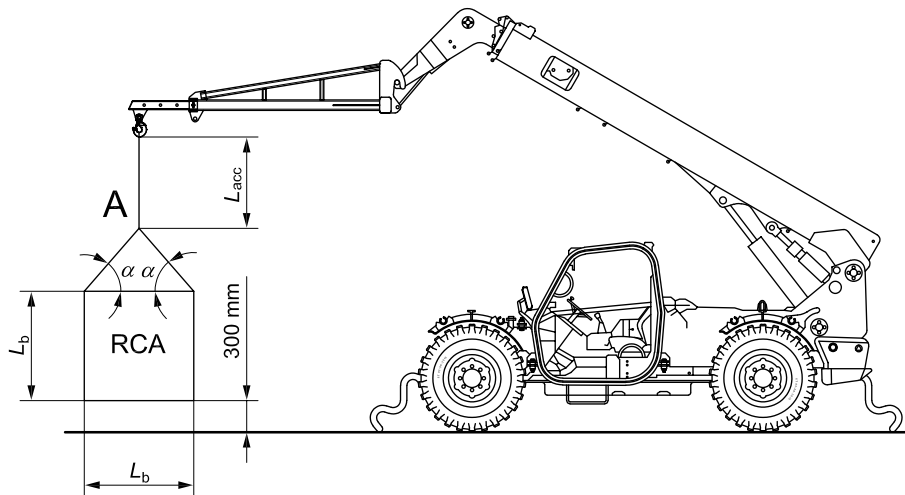

Key

- L_{acc} length of lifting accessories
- RCA rated capacity of the attachment
- L_b length of test cube
- α sling angle as defined by the manufacturer

Figure 2 — Position of the truck during dynamic structural test

5.4.3 Test procedure

- a) For the purpose of this test the truck shall be restrained to the ground to prevent tip-over. During the test, ensure that the load never collides with any object (e.g. the truck) or other personnel. Between each lift, pause until the load has stabilized.
- b) Operate the boom to the maximum possible extension allowed by the load chart keeping the load at 300 mm above the ground.
- c) Lift the boom to its maximum angle allowed by the manufacturer and ensuring that the load never collides with any object (e.g. the truck, the boom, etc.) or other personnel.
- d) Lower the boom at maximum speed. Stop the movement when the load is between 500 mm and 1000 mm from the ground according to [Figure 2](#).

5.4.4 Verification

The truck fitted with a specified lifting attachment shall be considered as complying with this test provided that no permanent deformation or component failure shall occur to any part of the truck and the specified lifting attachment.

The restraining means shall not be fully deployed to restrain the truck from tipping.

5.5 Additional requirements for pick and carry

5.5.1 General

The purpose of this test is to demonstrate the stability of the truck when travelling with a suspended load.

Stability requirements shall apply in all working zones and configurations to the truck model approved by the truck manufacturer for pick and carry operations as follows.

For pick and carry operation, at 8,75 % side slope or greater if specified by the manufacturer. For the purpose of test, the slope of the support surface and the truck chassis shall be on the same slope, that is, the chassis shall not be levelled.

The stability of the truck, when tested under static conditions, shall be such that the rated capacity is not greater than the appropriate percentage of the tipping load that has to be applied to tip the truck, as given in [Table 1](#).

Table 1 — Stability requirements for load rating conditions

Load rating condition	Stability requirement, percentage of tipping load (pick and carry) ^a
Freely suspended load (from hook)	66,6 ^b
^a Trucks configured in accordance with the manufacturer's pick and carry position.	
^b This percentage is allowed for a maximum travel speed of 0,4 m/s (walking speed).	

5.5.2 Stability by test loading

A test load of mass equivalent to the rated capacity divided by the stability requirement given in [Table 1](#) shall be suspended from the variable-reach truck throughout the duration of the test.

Travel motions shall not be used when under test load.

5.5.3 Requirements

The truck shall be considered to have complied with the static stability test provided the test load remains clear of the supporting surface with the truck in the tipping condition.

The tipping condition of a truck supporting a load is deemed to have been reached when the two wheels on the opposite side to the load lose contact with the supporting surface.

6 Information for use

6.1 Content requirements

The additional information for use shall be supplied by the manufacturer and shall include at least the following:

- information on the potential hazards associated with the suspended load, including but not limited to dynamic effects, additional effects of wind, visibility associated with boom position, and travel speed exceeding walking speed (i.e. > 0,4 m/s);
- where applicable, the permissible gradient for handling a freely suspended load during pick and carry operation;
- when stationary, to only handle a freely suspended load when the truck chassis is level;
- where applicable, information on restraining the load;

- e) if provided, the identification of suitable tether/tag lines points on the truck by marking in accordance with symbol ISO 7000:2014, n. 2096;
- f) information indicating that the lifting accessory and/or attachment is not intended for horizontal or side-pull of load and shall only be used according to the manufacturer's specifications;
- g) information that a competent slinger/rigger determines the most appropriate equipment and method to properly secure the load;
- h) a warning to not attempt to use the truck frame-levelling, movement of the carriage or attachment to compensate for a swinging load;
- i) information that the boom shall be retracted as far as practical during the pick and carry operation;
- j) information on starting, travelling, turning and stopping to prevent the load from swinging;

Items a) to i) where applicable may be added to the relevant load chart for pick and carry operations.

Bibliography

- [1] ISO 11525-4, *Rough-terrain trucks — User requirements — Part 4: Additional requirements for variable-reach trucks handling freely suspended loads*
- [2] ISO 16625, *Cranes and hoists — Selection of wire ropes, drums and sheaves*
- [3] ISO 17893, *Steel wire ropes — Vocabulary, designation and classification*
- [4] ISO 21308-5, *Road vehicles — Product data exchange between chassis and bodywork manufacturers (BEP) — Part 5: Coding of loader crane bodywork*
- [5] ISO 21898, *Packaging — Flexible intermediate bulk containers (FIBCs) for non-dangerous goods*

British Standards Institution (BSI)

BSI is the national body responsible for preparing British Standards and other standards-related publications, information and services.

BSI is incorporated by Royal Charter. British Standards and other standardization products are published by BSI Standards Limited.

About us

We bring together business, industry, government, consumers, innovators and others to shape their combined experience and expertise into standards-based solutions.

The knowledge embodied in our standards has been carefully assembled in a dependable format and refined through our open consultation process. Organizations of all sizes and across all sectors choose standards to help them achieve their goals.

Information on standards

We can provide you with the knowledge that your organization needs to succeed. Find out more about British Standards by visiting our website at bsigroup.com/standards or contacting our Customer Services team or Knowledge Centre.

Buying standards

You can buy and download PDF versions of BSI publications, including British and adopted European and international standards, through our website at bsigroup.com/shop, where hard copies can also be purchased.

If you need international and foreign standards from other Standards Development Organizations, hard copies can be ordered from our Customer Services team.

Subscriptions

Our range of subscription services are designed to make using standards easier for you. For further information on our subscription products go to bsigroup.com/subscriptions.

With **British Standards Online (BSOL)** you'll have instant access to over 55,000 British and adopted European and international standards from your desktop. It's available 24/7 and is refreshed daily so you'll always be up to date.

You can keep in touch with standards developments and receive substantial discounts on the purchase price of standards, both in single copy and subscription format, by becoming a **BSI Subscribing Member**.

PLUS is an updating service exclusive to BSI Subscribing Members. You will automatically receive the latest hard copy of your standards when they're revised or replaced.

To find out more about becoming a BSI Subscribing Member and the benefits of membership, please visit bsigroup.com/shop.

With a **Multi-User Network Licence (MUNL)** you are able to host standards publications on your intranet. Licences can cover as few or as many users as you wish. With updates supplied as soon as they're available, you can be sure your documentation is current. For further information, email bsmusales@bsigroup.com.

BSI Group Headquarters

389 Chiswick High Road London W4 4AL UK

Revisions

Our British Standards and other publications are updated by amendment or revision.

We continually improve the quality of our products and services to benefit your business. If you find an inaccuracy or ambiguity within a British Standard or other BSI publication please inform the Knowledge Centre.

Copyright

All the data, software and documentation set out in all British Standards and other BSI publications are the property of and copyrighted by BSI, or some person or entity that owns copyright in the information used (such as the international standardization bodies) and has formally licensed such information to BSI for commercial publication and use. Except as permitted under the Copyright, Designs and Patents Act 1988 no extract may be reproduced, stored in a retrieval system or transmitted in any form or by any means – electronic, photocopying, recording or otherwise – without prior written permission from BSI. Details and advice can be obtained from the Copyright & Licensing Department.

Useful Contacts:

Customer Services

Tel: +44 845 086 9001

Email (orders): orders@bsigroup.com

Email (enquiries): cservices@bsigroup.com

Subscriptions

Tel: +44 845 086 9001

Email: subscriptions@bsigroup.com

Knowledge Centre

Tel: +44 20 8996 7004

Email: knowledgecentre@bsigroup.com

Copyright & Licensing

Tel: +44 20 8996 7070

Email: copyright@bsigroup.com



...making excellence a habit.™