

Direct reduced iron and hot briquetted iron — Sampling and sample preparation

ICS 73.060.10

National foreword

This British Standard is the UK implementation of ISO 10835:2007.

The UK participation in its preparation was entrusted to Technical Committee ISE/58, Iron ores.

A list of organizations represented on this committee can be obtained on request to its secretary.

This publication does not purport to include all the necessary provisions of a contract. Users are responsible for its correct application.

Compliance with a British Standard cannot confer immunity from legal obligations.

This British Standard was published under the authority of the Standards Policy and Strategy Committee on 30 November 2007

© BSI 2007

ISBN 978 0 580 60937 4

Amendments issued since publication

| Amd. No. | Date | Comments |
|----------|------|----------|
| | | |
| | | |
| | | |
| | | |

INTERNATIONAL
STANDARD

ISO
10835

Second edition
2007-02-15

**Direct reduced iron and hot briquetted
iron — Sampling and sample preparation**

*Minerais de fer préréduits et fer briqueté à chaud — Échantillonnage et
préparation des échantillons*



Reference number
ISO 10835:2007(E)

Contents

Page

| | |
|--|-----------|
| Foreword..... | v |
| 1 Scope | 1 |
| 2 Normative references | 1 |
| 3 Terms and definitions | 2 |
| 4 General considerations for sampling and sample preparation | 3 |
| 4.1 Basic requirements | 3 |
| 4.2 Establishing a sampling scheme | 4 |
| 4.3 System verification | 5 |
| 5 Fundamentals of sampling and sample preparation | 5 |
| 5.1 Minimization of bias | 5 |
| 5.1.1 General | 5 |
| 5.1.2 Minimization of particle-size degradation | 5 |
| 5.1.3 Extraction of increments | 5 |
| 5.1.4 Increment mass | 6 |
| 5.2 Overall precision | 7 |
| 5.3 Quality variation | 9 |
| 5.4 Sampling precision and number of primary increments | 9 |
| 5.4.1 Mass-basis sampling | 9 |
| 5.4.2 Time-basis sampling | 9 |
| 5.5 Precision of sample preparation and overall precision | 11 |
| 5.5.1 General | 11 |
| 5.5.2 Preparation and measurement of gross sample | 11 |
| 5.5.3 Preparation and measurement of partial samples | 11 |
| 5.5.4 Preparation and measurement of each increment | 11 |
| 6 Methods of sampling | 12 |
| 6.1 Mass-basis sampling | 12 |
| 6.1.1 Mass of increment | 12 |
| 6.1.2 Quality variation | 13 |
| 6.1.3 Number of primary increments | 13 |
| 6.1.4 Sampling interval | 13 |
| 6.1.5 Methods of taking increments | 13 |
| 6.2 Time-basis sampling | 14 |
| 6.2.1 Mass of increment | 14 |
| 6.2.2 Quality variation | 14 |
| 6.2.3 Number of increments | 14 |
| 6.2.4 Sampling interval | 14 |
| 6.2.5 Methods of taking increments | 14 |
| 6.3 Stratified random sampling within fixed mass or time intervals | 15 |
| 6.3.1 General | 15 |
| 6.3.2 Fixed mass intervals | 15 |
| 6.3.3 Fixed time intervals | 15 |
| 7 Sampling from moving streams | 15 |
| 7.1 General | 15 |
| 7.2 Safety of operations | 16 |
| 7.3 Robustness of sampling installation | 16 |
| 7.4 Versatility of sampling system | 16 |
| 7.5 Primary samplers | 16 |
| 7.5.1 Location | 16 |
| 7.5.2 Types of primary sampler | 17 |

| | | |
|---------|--|----|
| 7.5.3 | General design criteria for primary cutters | 17 |
| 7.5.4 | Cutter aperture of primary sampler | 21 |
| 7.5.5 | Cutter speed of primary sampler | 21 |
| 7.6 | Secondary and subsequent samplers | 22 |
| 7.7 | On-line sample preparation | 22 |
| 7.7.1 | Arrangement for sample preparation | 22 |
| 7.7.2 | Crushers | 22 |
| 7.7.3 | Dividers | 22 |
| 7.7.4 | Dryers | 27 |
| 7.8 | Checking precision and bias | 27 |
| 7.9 | Cleaning and maintenance | 27 |
| 7.10 | Example of a flowsheet | 27 |
| 8 | Sampling from stationary situations | 29 |
| 9 | Stopped-belt reference sampling | 29 |
| 10 | Sample preparation | 30 |
| 10.1 | Fundamentals | 30 |
| 10.1.1 | General | 30 |
| 10.1.2 | Crushing and grinding | 30 |
| 10.1.3 | Mixing | 30 |
| 10.1.4 | Sample division | 30 |
| 10.1.5 | Mass of divided sample | 31 |
| 10.1.6 | Split use and multiple use of sample | 33 |
| 10.2 | Method of constituting partial samples or a gross sample | 33 |
| 10.2.1 | General | 33 |
| 10.2.2 | Method of constitution for mass-basis sampling | 33 |
| 10.2.3 | Method of constitution for time-basis sampling | 34 |
| 10.3 | Mechanical methods of division | 34 |
| 10.3.1 | Mechanical increment division | 34 |
| 10.3.2 | Other mechanical-division methods | 35 |
| 10.4 | Manual methods of division | 35 |
| 10.4.1 | Manual increment division | 35 |
| 10.4.2 | Fractional shoveling | 38 |
| 10.4.3 | Manual riffle division method | 39 |
| 10.5 | Preparation of test sample for physical testing | 40 |
| 10.6 | Preparation of test sample for moisture determination | 40 |
| 10.7 | Preparation of test sample for chemical analysis | 41 |
| 10.7.1 | Mass and particle size | 41 |
| 10.7.2 | Preparation to – 250 µm | 41 |
| 10.7.3 | Final preparation to – 160 µm | 42 |
| 10.7.4 | Distribution of samples for chemical analysis | 42 |
| 10.8 | Example of sample-preparation process | 43 |
| 11 | Packing and marking of sample | 43 |
| Annex A | (informative) Inspection of mechanical sampling systems | 45 |
| Annex B | (normative) Equation for number of increments | 49 |
| Annex C | (normative) Riffle dividers | 52 |

Foreword

ISO (the International Organization for Standardization) is a worldwide federation of national standards bodies (ISO member bodies). The work of preparing International Standards is normally carried out through ISO technical committees. Each member body interested in a subject for which a technical committee has been established has the right to be represented on that committee. International organizations, governmental and non-governmental, in liaison with ISO, also take part in the work. ISO collaborates closely with the International Electrotechnical Commission (IEC) on all matters of electrotechnical standardization.

International Standards are drafted in accordance with the rules given in the ISO/IEC Directives, Part 2.

The main task of technical committees is to prepare International Standards. Draft International Standards adopted by the technical committees are circulated to the member bodies for voting. Publication as an International Standard requires approval by at least 75 % of the member bodies casting a vote.

Attention is drawn to the possibility that some of the elements of this document may be the subject of patent rights. ISO shall not be held responsible for identifying any or all such patent rights.

ISO 10835 was prepared by Technical Committee ISO/TC 102, *Iron ore and direct reduced iron*, Subcommittee SC 1, *Sampling*.

This second edition cancels and replaces the first edition (ISO 10835:1995), which has been technically revised.

Direct reduced iron and hot briquetted iron — Sampling and sample preparation

WARNING — This International Standard may involve hazardous materials, operations and equipment, and does not purport to address all of the safety issues associated with its use. It is the responsibility of the user of this standard to establish appropriate health and safety practices and determine the applicability of regulatory limitations prior to use.

1 Scope

This International Standard gives

- a) the underlying theory,
- b) the basic principles for sampling and preparation of samples, and
- c) the basic requirements for the design, installation and operation of sampling systems,

for mechanical sampling, manual sampling and preparation of samples taken from a lot under transfer, to determine the chemical composition, moisture content and physical properties of the lot.

The methods specified in this International Standard are applicable to both the loading and discharging of direct reduced iron (DRI) and hot briquetted iron (HBI), by means of belt conveyors and other ore handling equipment to which a mechanical sampler may be installed or where stopped-belt sampling may safely be conducted. In this International Standard, DRI includes both reduced pellets and reduced lump ores.

CAUTION — Direct reduced iron (DRI) and, in some cases, hot briquetted iron (HBI), for example, with low density or high fines content, may react with water and air to produce hydrogen and heat. The heat produced may cause ignition. Therefore, due consideration shall be given to the safety of operators by respecting applicable regulations or international codes.

2 Normative references

The following referenced documents are indispensable for the application of this document. For dated references, only the edition cited applies. For undated references, the latest edition of the referenced document (including any amendments) applies.

ISO 565:1990, *Test sieves — Metal wire cloth, perforated metal plate and electroformed sheet — Nominal sizes of openings*

ISO 3084:1998, *Iron ores — Experimental methods for evaluation of quality variation*

ISO 3085:2002, *Iron ores — Experimental methods for checking the precision of sampling, sample preparation and measurement*

ISO 3086:1998, *Iron ores — Experimental methods for checking the bias of sampling*

ISO 3087:1998, *Iron ores — Determination of moisture content of a lot*

ISO 3534-1:2006, *Statistics — Vocabulary and symbols — Part 1: General statistical terms and terms used in probability*

ISO 4701:1999, *Iron ores — Determination of size distribution by sieving*

ISO 11323:2002, *Iron ores and direct reduced iron — Vocabulary*

3 Terms and definitions

For the purposes of this document, the terms and definitions given in ISO 11323 and the following apply.

- 3.1 lot**
discrete and defined quantity of DRI or HBI for which quality characteristics are to be assessed
- 3.2 increment**
quantity of DRI or HBI collected in a single operation of a sampling device
- 3.3 sample**
relatively small quantity of DRI or HBI, taken from a lot so as to be representative in respect of the quality characteristics to be assessed
- 3.4 partial sample**
sample consisting of less than the complete number of increments needed for a gross sample
- 3.5 gross sample**
sample comprising all increments, entirely representative of all quality characteristics of a lot
- 3.6 test sample**
sample prepared to meet all specific conditions for a test
- 3.7 test portion**
part of a test sample that is actually and entirely subjected to the specific test
- 3.8 stratified sampling**
sampling of a lot carried out by taking increments from systematically specified positions and in appropriate proportions from identified parts called strata
- NOTE Examples of strata, based on time, mass or space, include production periods (e.g. 5 min), production masses (e.g. 1 000 t), holds in vessels, wagons in a train, or containers.
- 3.9 systematic sampling**
selection of increments at regular intervals from a lot
- 3.10 mass-basis sampling**
sampling carried out so that increments are taken at equal mass intervals, increments being, as near as possible, of uniform mass

3.11**time-basis sampling**

sampling carried out so that increments are taken from free-falling streams, or from conveyors, at uniform time intervals, the mass of each increment being proportional to the mass flow rate at the instant of taking the increment

3.12**proportional sample division**

division of samples or increments such that the mass of each retained divided portion is a fixed proportion of the mass being divided

3.13**constant-mass division**

division of samples or increments such that the retained divided portions are of almost uniform mass, irrespective of variations in mass of the samples or increments being divided

NOTE This method is required for sampling on a mass basis. "Almost uniform" means that variations in mass are less than 20 % in terms of the coefficient of variation.

3.14**split use of sample**

separate use of parts of a sample, as test samples for separate determinations of quality characteristics

3.15**multiple use of sample**

use of a sample in its entirety for the determination of one quality characteristic, followed by the use of the same sample in its entirety for the determination of one or more other quality characteristics

3.16**nominal top size of DRI**

smallest aperture size, within the range of the R20 Series (in ISO 565, square opening), such that no more than 5 % by mass of the DRI is retained on the sieve

3.17**nominal top size of HBI**

prior to crushing, the largest average dimension of HBI briquettes, or, after crushing, the smallest aperture size, within the range of the R20 Series (in ISO 565, square opening), such that no more than 5 % by mass of the HBI is retained on the sieve

4 General considerations for sampling and sample preparation

4.1 Basic requirements

The basic requirement for a correct sampling scheme is that all of the DRI or HBI in the lot has an equal opportunity of being selected and becoming part of the partial sample or gross sample for analysis. Any deviation from this basic requirement can result in an unacceptable loss of accuracy and precision. An incorrect sampling scheme cannot be relied on to provide representative samples.

The best sampling location to satisfy the above requirement is at a transfer point between conveyor belts. Here, the full cross-section of the DRI or HBI stream can be conveniently intercepted at regular intervals, enabling representative samples to be obtained. Alternatively, samples may be taken from a stopped conveyor belt, provided a full cross-section of DRI or HBI of adequate length is taken from the conveyor (see Clause 9).

In situ sampling of ships, stockpiles, wagons, containers and bunkers is not permitted, because there is no suitable sampling device that can be driven down to the bottom and then extract the full column of DRI or HBI. Consequently, all parts of the lot do not have an equal opportunity of being sampled. The only effective procedure is sampling from a conveyor belt when the DRI or HBI is being conveyed to or from the ship, stockpile, container or bunker.

Sampling shall be carried out by systematic sampling or stratified random sampling either on a mass basis (see 6.1 or 6.3.2) or on a time basis (see 6.2 or 6.3.3). However, if periodic variations in quality or quantity are present, sampling shall be restricted to stratified random sampling within fixed mass or time intervals (see 6.3.2 or 6.3.3).

The methods used for sampling and sample preparation depend on the final choice of the sampling scheme, and on the steps necessary to minimize possible biases and obtain acceptable overall precision.

Moisture samples shall be processed as soon as possible and test portions weighed immediately. If this is not possible, samples shall be stored in impervious airtight containers with a minimum of free air space to minimize any change in moisture content, but should be prepared without delay.

4.2 Establishing a sampling scheme

The procedure for establishing a sampling scheme is as follows:

- a) identify the lot to be sampled and the quality characteristics to be determined;
- b) ascertain the nominal top size;
- c) determine the mass of increment considering the nominal top size, the DRI- or HBI-handling equipment and the device for taking increments;
- d) specify the precision required;
- e) ascertain the quality variation, σ_w , of the lot in accordance with ISO 3084, or, if this is not possible, assume a "large" quality variation as specified in 5.3;
- f) determine the minimum number of primary increments, n_1 , to be taken from the lot for systematic or stratified random sampling;
- g) determine the sampling interval, in tonnes, for mass-basis sampling, or in minutes for time-basis sampling;
- h) determine the sampling location and the method of taking increments;
- i) take increments having almost uniform mass for mass-basis sampling or having a mass proportional to the flow rate of the stream at the time of sampling for time-basis sampling; Increments are to be taken at the intervals determined in item g) during the entire period of handling the lot;
- j) determine whether the sample is for split use or multiple use;
- k) establish the method of combining increments into a gross sample or partial samples;
- l) establish the sample-preparation procedure, including division, crushing, mixing and drying;
- m) dry the samples, if necessary, except for the moisture sample;
- n) crush the samples, if necessary, except for the size sample and some physical testing samples;
- o) divide samples according to the minimum mass of divided sample for a given nominal top size, employing constant mass or proportional division for mass-basis sampling, or proportional division for time-basis sampling;
- p) prepare the test sample.

Sample containers for DRI and crushed HBI shall be suitable for storing and transporting the material in very well-protected conditions. Samples shall be stored in airtight containers and shall not be left unprotected from the atmosphere at any stage.

4.3 System verification

Stopped-belt sampling is the reference method for collecting samples against which mechanical and manual sampling procedures may be compared to establish that they are unbiased in accordance with the procedures specified in ISO 3086. However, before any bias tests are conducted, sampling and sample-preparation systems shall first be inspected to confirm that they conform to the correct design principles specified in this International Standard. Inspections shall also include an examination of whether any loading, unloading or reclaiming procedures could produce periodic variations in quality, in phase with the taking of increments, e.g. size distribution. When such cyclic variations occur, the source of the variations shall be investigated to determine the practicability of eliminating the variations. If this is not possible, stratified random sampling shall be carried out (see 6.3).

An example of a suitable inspection procedure and checklist is provided in Annex A. This will quickly reveal any serious deficiencies in the sampling or sample-preparation system and may avoid the need for expensive bias testing. Consequently, sampling systems shall be designed and constructed in a manner that facilitates a regular verification of correct operation.

Regular checks of quality variation and precision shall also be carried out in accordance with ISO 3084 and ISO 3085 to monitor variations in quality variation and to verify the precision of sampling, sample preparation and analysis. This is particularly important for new products or new sampling systems, or when significant changes are made to existing systems. Sampling systems should therefore be designed at the outset to enable constitution of duplicate samples for determining quality variation and for checking precision.

5 Fundamentals of sampling and sample preparation

5.1 Minimization of bias

5.1.1 General

Minimization of bias in sampling and sample preparation is vitally important. Unlike precision, which can be improved by collecting more increments or repeating measurements, bias cannot be reduced by replicating measurements. Consequently, minimizing or preferably eliminating possible biases is more important than improving precision. Sources of bias that can be completely eliminated at the outset by correct design of the sampling and sample-preparation system include sample spillage, sample contamination and incorrect extraction of increments, while sources that can be minimized but not completely eliminated include loss of dust and particle-size degradation (for size determination). Samples should be as dry as possible before crushing.

5.1.2 Minimization of particle-size degradation

Minimization of particle-size degradation of samples used for determination of size distribution is vital to reduce bias in the measured size distribution. To prevent particle-size degradation, it is essential to keep free-fall drops to a minimum.

5.1.3 Extraction of increments

It is essential that increments be extracted from the lot in such a manner that all the DRI or HBI has an equal opportunity of being selected and becoming part of the final sample for analysis, irrespective of the size, mass or density of individual particles. If this requirement is not respected, bias is easily introduced. This results in the following design requirements for sampling and sample-preparation systems:

- a) a complete cross-section of the DRI or HBI stream shall be taken when sampling from a moving stream (see 7.5) or a stopped belt (see Clause 9);
- b) the aperture of the sample cutter shall be at least three times the nominal top size of the DRI or HBI for primary sampling, or 10 mm for subsequent stages, whichever is the greater (see 7.5.4);

- c) the speed of the sample cutter shall not exceed 0.6 m/s, unless the cutter aperture is correspondingly increased (see 7.5.5);
- d) the sample cutter shall travel through the stream at uniform speed (see 7.5.3), both the leading and trailing edges of the cutter clearing the stream at the end of its traverse;
- e) the lips on the sample cutter shall be parallel for straight-path samplers and radial for rotary cutters (see 7.5.3), and these conditions shall be maintained as the cutter lips wear;
- f) changes in moisture content, dust losses and sample contamination shall be avoided;
- g) free-fall drops shall be kept to a minimum to reduce size degradation of the DRI or HBI and hence minimize bias in size distribution;
- h) primary cutters shall be located as near as possible to the loading or discharging point to further minimize the effects of size degradation;

Sampling systems shall be designed to accommodate the maximum nominal top size and flow rate of the DRI or HBI being sampled. Detailed design requirements for sampling and sample-preparation systems are provided in Clauses 7, 8, 9 and 10.

5.1.4 Increment mass

5.1.4.1 General

The increment mass required to obtain an unbiased sample can be calculated for typical sampling situations (see 5.1.4.2 and 5.1.4.3). Comparing the calculated masses with the actual increment masses is useful for checking the design and operation of sampling systems. If the difference is significant, the cause shall be identified and corrective action taken to rectify the problem.

5.1.4.2 Increment mass for falling-stream sampling

The mass of increment, m_i , in kilograms, to be taken (mechanically or manually) by a cutter-type primary sampler from the DRI or HBI stream at the discharge end of a conveyor belt is given by:

$$m_i = \frac{ql_1}{3,6v_c} \tag{1}$$

where

- q is the flow rate, in tonnes per hour, of DRI or HBI on the conveyor belt;
- l_1 is the cutter aperture, in metres, of the primary sampler;
- v_c is the cutter speed, in metres per second, of the primary sampler.

The minimum increment mass that can be taken, while still avoiding bias, is determined by the minimum cutter aperture specified in 7.5.4 and the maximum cutter speed specified in 7.5.5.

5.1.4.3 Increment mass for stopped-belt sampling

The mass of increment, m_i , in kilograms, to be taken manually from a stopped belt is equal to the mass of a complete cross-section of DRI or HBI on the conveyor. It is given by the equation:

$$m_i = \frac{ql_2}{3,6v_B} \tag{2}$$

where

q is the flow rate, in tonnes per hour, of DRI or HBI on the conveyor belt;

l_2 is the length of the section of DRI or HBI removed from the conveyor, in metres;

v_B is the speed of the conveyor belt, in metres per second.

The minimum increment mass that can be taken, while still avoiding bias, is determined by the minimum length of the section of DRI or HBI removed from the conveyor, i.e. $3d$, where d is the nominal top size of the DRI or HBI in metres, subject to a minimum of 0,01 m for DRI and crushed HBI. In practice, the section of HBI briquettes removed from a conveyor is usually 1 m.

5.2 Overall precision

This International Standard is designed to attain the overall precision, β_{SPM} , at a probability level of 95 %, given in Table 1 for the chemical (total iron, metallic iron, carbon, silica, alumina, phosphorus, sulfur and moisture content) and physical (percent size fraction, apparent density, bulk density, tumble index and abrasion index) characteristics of the lot. Higher precision values may be adopted if required. The precision shall be determined in accordance with ISO 3085.

The overall precision, β_{SPM} , is a measure of the combined precision of sampling, sample preparation and measurement, and is twice the standard deviation of sampling, sample preparation and measurement, σ_{SPM} , expressed as an absolute percentage, i.e.:

$$\sigma_{\text{SPM}} = \sqrt{\sigma_{\text{S}}^2 + \sigma_{\text{P}}^2 + \sigma_{\text{M}}^2} \quad (3)$$

$$\beta_{\text{SPM}} = 2\sigma_{\text{SPM}} = 2\sqrt{\sigma_{\text{S}}^2 + \sigma_{\text{P}}^2 + \sigma_{\text{M}}^2} \quad (4)$$

$$\sigma_{\text{S}} = \frac{\sigma_{\text{W}}}{\sqrt{n_1}} \quad (5)$$

where

σ_{S} is the sampling standard deviation;

σ_{P} is the sample-preparation standard deviation;

σ_{M} is the measurement standard deviation;

σ_{W} is the quality variation of the DRI or HBI;

n_1 is the number of primary increments.

Equations (3), (4) and (5) are based on the theory of stratified sampling (see Annex B for more details). The number of primary increments to be taken for a lot is dependent on the sampling precision required and on the quality variation of the DRI or HBI to be sampled. Thus, before the number of primary increments can be determined, it is necessary to define:

- a) the sampling precision, β_{S} , to be attained;
- b) the quality variation, σ_{W} , of the DRI or HBI to be sampled.

Table 1 — Overall precision, β_{SPM} (values as absolute percentages)

| Quality characteristics | | Approximate overall precision | | |
|--|-------------------------------------|-------------------------------|------------------|-------------|
| | | β_{SPM} | | |
| | | Mass of lot (t) | | |
| | | 45 000 to 70 000 | 15 000 to 45 000 | 0 to 15 000 |
| Total iron content | | 0,3 | 0,4 | 0,5 |
| Metallic iron content | | 1,0 | 1,2 | 1,5 |
| Carbon content | | 0,10 | 0,12 | 0,15 |
| Silica content | | 0,10 | 0,12 | 0,15 |
| Alumina content | | 0,10 | 0,12 | 0,15 |
| Phosphorus content | | 0,002 0 | 0,002 4 | 0,003 0 |
| Sulfur content | | 0,002 0 | 0,002 4 | 0,003 0 |
| Moisture content | | 0,10 | 0,12 | 0,15 |
| Size (– 31,5 + 6,3 mm DRI lump) | – 6,3 mm fraction mean 10 % | 2,0 | 2,2 | 2,5 |
| Size (DRI pellets) | – 6,3 mm fraction mean 5 % | 0,8 | 0,9 | 1,0 |
| Size (– 100 mm HBI) | – 25 + 6,3 mm fraction mean 10 % | 0,3 | 0,4 | 0,5 |
| | – 6,3 mm fraction mean 10 % | 0,3 | 0,4 | 0,5 |
| Apparent density (HBI only) | | 0,10 | 0,12 | 0,15 |
| Bulk density | | 0,10 | 0,12 | 0,15 |
| Tumble index | | 0,5 | 0,6 | 0,7 |
| Abrasion index | | 0,5 | 0,6 | 0,7 |
| NOTE The values of β_{SPM} are indicative and subject to confirmation through international tests. | | | | |

NOTE When on-line sample preparation takes place within the sample plant away from the preparation laboratory, the distinction between sampling and sample preparation becomes less clear. In this case, the precision of on-line sample preparation may be included in either the sampling precision or in the sample-preparation precision. Sample preparation is strictly a sampling operation, because a representative part of the sample is selected for subsequent processing. Hence, the most rigorous approach is to break up the sampling standard deviation into its components for each sampling stage, in which case Equation (3) becomes:

$$\sigma_{SPM} = \sqrt{\sigma_{S1}^2 + \sigma_{S2}^2 + \sigma_{S3}^2 + \sigma_P^2 + \sigma_M^2}$$

where

σ_{S1} is the sampling standard deviation for primary sampling;

σ_{S2} is the sampling standard deviation for secondary sampling;

σ_{S3} is the sampling standard deviation for tertiary sampling.

Using this approach, the precision of each sampling stage can be separately determined and optimized, resulting in a fully optimized sampling and sample-preparation regime.

5.3 Quality variation

The quality variation, σ_w , is a measure of the heterogeneity of the lot and is the standard deviation of the quality characteristics of increments within strata for mass-basis systematic sampling. The characteristics to be selected for determining quality variation include all the chemical and physical characteristics of the DRI or HBI being sampled.

The value of σ_w shall be measured experimentally for each type or brand of DRI or HBI and for each handling plant under normal operating conditions, in accordance with ISO 3084. The quality variation of the DRI or HBI may then be classified into three categories according to its magnitude as specified in Table 2. In the case of time-basis sampling, if the flow rate of the DRI or HBI is uniform on the belt, then time-basis sampling is the same as mass-basis sampling and ISO 3084 can be applied.

All DRI or HBI, of which the quality variation is unknown, shall be considered to have a “large” quality variation. In this case, measurements shall be conducted at the earliest possible opportunity in accordance with ISO 3084 to determine the quality variation.

When separate samples are taken for the determination of chemical composition and physical characteristics, the quality variation for the individual characteristics shall be adopted. When the sample is used for the determination of more than one quality characteristic, the largest classification category for quality variation shall be adopted.

5.4 Sampling precision and number of primary increments

5.4.1 Mass-basis sampling

When the value of σ_w is known, the number of primary increments, n_1 , can be calculated for the desired sampling precision, β_s , as follows:

$$n_1 = \left(\frac{2\sigma_w}{\beta_s} \right)^2 \quad (6)$$

This is the preferable method of determining the number of primary increments. However, when the value of σ_w is classified in terms of large, medium or small quality variation in accordance with Table 2, Table 3 may be used to determine the minimum number of primary increments required for the sampling precision, β_s , specified in the table. In Table 3, the sampling precisions have been increased slightly for smaller lot sizes as a trade-off between sampling cost and the uncertainty in the commercial value of the lot.

NOTE 1 The values of β_s are indicative and subject to confirmation through international test work.

NOTE 2 The values of n_1 may be increased or decreased to alter the sampling precision. For example, if the number of increments is $2n_1$, then β_s will be improved by a factor of $1/\sqrt{2} = 0,71$; and if it is $n_1/2$, then β_s will be worsened by a factor of $\sqrt{2} = 1,4$.

5.4.2 Time-basis sampling

The minimum number of primary increments shall preferably be determined using Equation (6), but Table 3 may also be used, as specified in 5.4.1.

Table 2 — Classification of quality variation, σ_w (values as absolute percentages)

| Quality characteristics | | Classification of quality variation (σ_w) | | |
|---------------------------------|----------------------------------|--|-------------------------------|--------------------|
| | | Large | Medium | Small |
| Total iron content | | $\sigma_w \geq 1,5$ | $1,5 > \sigma_w \geq 1,0$ | $\sigma_w < 1,0$ |
| Metallic iron content | | $\sigma_w \geq 4,0$ | $4,0 > \sigma_w \geq 3,0$ | $\sigma_w < 3,0$ |
| Carbon content | | $\sigma_w \geq 0,5$ | $0,5 > \sigma_w \geq 0,3$ | $\sigma_w < 0,3$ |
| Silica content | | $\sigma_w \geq 0,5$ | $0,5 > \sigma_w \geq 0,3$ | $\sigma_w < 0,3$ |
| Alumina content | | $\sigma_w \geq 0,5$ | $0,5 > \sigma_w \geq 0,3$ | $\sigma_w < 0,3$ |
| Phosphorus content | | $\sigma_w \geq 0,011$ | $0,011 > \sigma_w \geq 0,007$ | $\sigma_w < 0,007$ |
| Sulfur content | | $\sigma_w \geq 0,011$ | $0,011 > \sigma_w \geq 0,007$ | $\sigma_w < 0,007$ |
| Moisture content | | $\sigma_w \geq 0,5$ | $0,5 > \sigma_w \geq 0,3$ | $\sigma_w < 0,3$ |
| Size (– 31,5 + 6,3 mm DRI lump) | – 6,3 mm fraction mean 10 % | $\sigma_w \geq 5$ | $5 > \sigma_w \geq 3,75$ | $\sigma_w < 3,75$ |
| Size (DRI pellets) | – 6,3 mm fraction mean 5 % | $\sigma_w \geq 3,0$ | $3 > \sigma_w \geq 2,25$ | $\sigma_w < 2,25$ |
| Size (– 100 mm HBI) | – 25 + 6,3 mm fraction mean 10 % | $\sigma_w \geq 1,5$ | $1,5 > \sigma_w \geq 1,0$ | $\sigma_w < 1,0$ |
| | – 6,3 mm fraction mean 10 % | $\sigma_w \geq 1,5$ | $1,5 > \sigma_w \geq 1,0$ | $\sigma_w < 1,0$ |
| Apparent density | | $\sigma_w \geq 0,5$ | $0,5 > \sigma_w \geq 0,3$ | $\sigma_w < 0,3$ |
| Bulk density | | $\sigma_w \geq 0,5$ | $0,5 > \sigma_w \geq 0,3$ | $\sigma_w < 0,3$ |
| Tumble index | | $\sigma_w \geq 2,0$ | $2,0 > \sigma_w \geq 1,5$ | $\sigma_w < 1,5$ |
| Abrasion index | | $\sigma_w \geq 2,0$ | $2,0 > \sigma_w \geq 1,5$ | $\sigma_w < 1,5$ |

NOTE The values of σ_w are indicative and subject to confirmation through international test work.

Table 3 — Example of minimum number of increments required, n_1 , for desired sampling precision, β_s

| Mass of lot (1 000 t) | | Sampling precision | | | | | | | | Number of primary increments | | |
|--|----------|--------------------|-------------|---|--------|---|----------------------------------|--------------|----------------|------------------------------|----|----|
| | | Total Fe | Metallic Fe | SiO ₂ Al ₂ O ₃ C or H ₂ | P or S | β_s – 25 + 6,3 mm or – 6,3 mm fraction | Apparent density or bulk density | Tumble index | Abrasion index | n_1 | | |
| Quality variation Large (L), Medium (M) or Small (S) | L | | | | | | | | | M | S | |
| Over 45 | Up to 70 | 0,28 | 0,78 | 0,09 | 0,0020 | 0,28 | 0,09 | 0,39 | 0,39 | 160 | 80 | 40 |
| Over 30 | Up to 45 | 0,30 | 0,84 | 0,10 | 0,0022 | 0,30 | 0,10 | 0,42 | 0,42 | 140 | 70 | 35 |
| Over 15 | Up to 30 | 0,32 | 0,90 | 0,10 | 0,0023 | 0,32 | 0,10 | 0,45 | 0,45 | 120 | 60 | 30 |
| Over 0 | Up to 15 | 0,35 | 0,99 | 0,11 | 0,0025 | 0,35 | 0,11 | 0,50 | 0,50 | 110 | 50 | 25 |

5.5 Precision of sample preparation and overall precision

5.5.1 General

The precision of sample preparation depends on the choice of the sampling scheme. However, it can be improved if sample preparation is carried out first on individual increments or partial samples at an appropriate stage of sample preparation and then the divided increments or partial samples are combined into a gross sample.

The overall precision in terms of the standard deviation, σ_{SPM} , where sample preparation and measurement are carried out on the gross sample, on each of the partial samples or on each of the increments, is specified in 5.5.2 to 5.5.4.

5.5.2 Preparation and measurement of gross sample

When a gross sample for a lot is constituted by combining all increments and n_2 measurements are carried out on the gross sample, the overall precision will be:

$$\sigma_{\text{SPM}}^2 = \sigma_{\text{S}}^2 + \sigma_{\text{P}}^2 + \frac{\sigma_{\text{M}}^2}{n_2} \quad (7)$$

where σ_{P} is the precision of preparing a test sample from the gross sample.

5.5.3 Preparation and measurement of partial samples

When n_3 partial samples consisting of an equal number of increments are constituted, and n_2 measurements are carried out on each partial sample, the overall precision will be:

$$\sigma_{\text{SPM}}^2 = \sigma_{\text{S}}^2 + \frac{\sigma_{\text{P}}^2 + \frac{\sigma_{\text{M}}^2}{n_2}}{n_3} \quad (8)$$

where σ_{P} is the precision of preparing a test sample from each partial sample.

Furthermore, when the above n_3 partial samples are combined into a gross sample at an appropriate stage (– 10 mm or less) after individual sample preparation, and n_2 measurements are carried out on the gross sample, the overall precision will be:

$$\sigma_{\text{SPM}}^2 = \sigma_{\text{S}}^2 + \frac{\sigma_{\text{P1}}^2}{n_3} + \sigma_{\text{P2}}^2 + \frac{\sigma_{\text{M}}^2}{n_2} \quad (9)$$

where

σ_{P1} is the precision of preparing each partial sample prior to constituting the gross sample;

σ_{P2} is the precision of preparing a test sample from the gross sample.

5.5.4 Preparation and measurement of each increment

When n_2 measurements are carried out on each increment, the overall precision will be:

$$\sigma_{\text{SPM}}^2 = \sigma_{\text{S}}^2 + \frac{\sigma_{\text{P}}^2 + \frac{\sigma_{\text{M}}^2}{n_2}}{n_1} \quad (10)$$

where

σ_P is the precision of preparing a test sample from each increment;

n_1 is the number of primary increments.

Furthermore, when all the increments are combined into a gross sample at an appropriate stage (– 10 mm or less) after individual sample preparation, and n_2 measurements are carried out on the gross sample, the overall precision will be:

$$\sigma_{SPM}^2 = \sigma_S^2 + \frac{\sigma_{P1}^2}{n_1} + \sigma_{P2}^2 + \frac{\sigma_M^2}{n_3} \quad (11)$$

where

σ_{P1} is the precision of preparing each increment prior to constituting the gross sample;

σ_{P2} is the precision of preparing a test sample from the gross sample.

NOTE Each sample-preparation stage has its own variance, so the total variance will be greater than that for a single stage. It is desirable to use larger samples for those stages of sample preparation for which this does not greatly increase costs. This needs to be taken into account when optimizing sample-preparation schemes.

6 Methods of sampling

6.1 Mass-basis sampling

6.1.1 Mass of increment

The mass of increment shall be determined according to 5.1.4.

Increments shall be taken so that they are of “almost uniform mass”, i.e., the coefficient of variation of increment masses shall be less than 20 %. The coefficient of variation, CV, is defined as the ratio of standard deviation, σ_{mass} , to the mean value, \bar{m} , of the mass of the increments, expressed as a percentage as follows:

$$CV = \frac{100\sigma_{\text{mass}}}{\bar{m}} \quad (12)$$

For example, if the average mass of increment is to be 100 kg, the increments should be taken in such a manner that 95 % of the increments vary between 60 and 140 kg, with an average of 100 kg. Provision must therefore be made, either in the manner in which the increments are taken or by subsequent weighing and division of each increment, to ensure that they have almost uniform mass.

To obtain increments of almost uniform mass, the following measures shall be taken:

- a) installation of a variable-speed cutter which varies its speed increment-by-increment so that the speed is proportional to the flow rate of ore on the conveyor belt at the time of taking each increment;
- b) control of the flow rate on the conveyor belt ahead of the sampling point to reduce variations in flow rate;
- c) installation of equipment which rejects increments of non-uniform mass and immediately re-starts the primary sampler.

If the coefficient of variation of increment masses is 20 % or greater, each increment may be subjected to division (according to the rules of division) and the quality characteristics determined. Alternatively, divided increments of “almost uniform mass” may be combined at an appropriate stage of division into a partial sample or a gross sample.

6.1.2 Quality variation

The quality variation shall be determined experimentally in accordance with ISO 3084.

6.1.3 Number of primary increments

The number of primary increments shall be determined in accordance with 5.4.1.

6.1.4 Sampling interval

The mass interval, Δm , in tonnes, between increments shall be calculated from the equation:

$$\Delta m \leq \frac{m_L}{n_1} \quad (13)$$

where

m_L is the mass, in tonnes, of the lot;

n_1 is the number of primary increments determined in 5.4.1.

The mass interval selected shall be smaller than that calculated above, to ensure that the minimum number of primary increments is greater than that determined in accordance with 5.4.1.

6.1.5 Methods of taking increments

Each increment shall be taken at one time by a single motion or by a complete cycle of the sampling device, so that a full cross-section of the DRI or HBI stream is taken. Free-fall drops of increments shall be kept to a minimum to reduce size degradation of the DRI or HBI, and hence minimize bias in size distribution.

NOTE 1 A complete cycle may involve the sampler taking a forward and return cut through the DRI or HBI stream.

NOTE 2 Stopped-belt sampling may also be used to take a full cross-section of the DRI or HBI stream.

The first increment shall be taken after a randomly selected tonnage has been handled within the first mass interval after commencing the handling operation. Subsequent increments shall be taken at the fixed mass interval determined in 6.1.4 until handling of the lot has been completed. When the calculated mass of the sample is less than that required for testing (size determination, physical testing, etc.), the number and/or mass of the increments shall be increased.

Either of the following two kinds of cutters may be employed for the primary sampler:

- a) a fixed-speed cutter of which the cutting speed is constant during the course of handling the entire lot;
- b) a variable-speed cutter of which the cutting speed is constant while cutting the stream but can be regulated, increment by increment, according to the flow rate of DRI or HBI on the conveyor belt.

Sampling shall be carried out at the nearest possible point to the loading or discharging facilities, preferably immediately before or after the point of weighing.

6.2 Time-basis sampling

6.2.1 Mass of increment

The mass of increment shall be proportional to the flow rate at the time of sampling. When a test sample is prepared from each increment or partial sample, the mass of each increment or partial sample shall be determined in order to obtain the weighted mean of the quality characteristics for the lot. Alternatively, the tonnage of DRI or HBI that the sample represents may be used to obtain the weighted mean.

6.2.2 Quality variation

When the variation in the flow rate is less than 20 % in terms of the coefficient of variation, ISO 3084 shall be used to obtain an approximate value for the quality variation.

6.2.3 Number of increments

The number of primary increments shall be determined in accordance with 5.4.2.

6.2.4 Sampling interval

The time interval, Δt , in minutes, between increments shall be calculated from the equation:

$$\Delta t \leq \frac{60m_L}{q_{\max}n_1} \quad (14)$$

where

m_L is the mass, in tonnes, of the lot;

q_{\max} is the maximum flow rate, expressed in tonnes per hour, of DRI or HBI on the conveyor belt;

n_1 is the number of primary increments determined in 5.4.2.

The time interval between taking increments that is selected shall be smaller than that calculated, to ensure that the minimum number of primary increments is greater than that determined in accordance with 5.4.2.

6.2.5 Methods of taking increments

Each increment shall be taken once by a single motion or by a complete cycle of the sampling device, so that a full cross-section of the DRI or HBI stream is taken. Free-fall drops of increments shall be kept to a minimum to reduce size degradation of the DRI or HBI, and hence minimize bias in size distribution.

NOTE 1 A sampler may take a forward and return cut through the DRI or HBI stream in a complete cycle.

NOTE 2 Stopped-belt sampling may also be used to take a full cross-section of the DRI or HBI stream.

The first increment shall be taken at random within the first time interval from the start of the handling operation. Subsequent increments shall be taken at the fixed time interval determined in 6.2.4 until handling of the lot is completed. When the calculated mass of the sample is less than that required for testing (size determination, physical testing, etc.), the sampling interval shall be shortened.

A fixed-speed cutter, of which the cutting speed is constant during the course of handling the entire lot, shall be employed for the primary sampler.

Sampling shall be carried out at the nearest possible point to the loading or discharging facilities, preferably immediately before or after the point of weighing.

6.3 Stratified random sampling within fixed mass or time intervals

6.3.1 General

Sampling shall preferably be carried out by systematic sampling either on a mass basis (see 6.1) or on a time basis (see 6.2). However, when periodic variations in quality or quantity occur within a period approximately equal to any multiple of the proposed sampling interval, stratified random sampling within fixed mass or time intervals should be used.

Due to the nature of stratified random sampling, successive increments may be collected close together in space or time. Consequently, the sampling system shall be designed to handle two increments in quick succession.

6.3.2 Fixed mass intervals

For stratified random sampling within fixed mass intervals, the procedure is as specified in 6.1 except that, when the mass interval has been set, the sample cutter is programmed to take one primary increment at random within this mass interval. This is achieved by using a random number generator, capable of giving a random mass number within the mass interval (determined in 6.1.4), which activates the sample cutter at the mass corresponding to the mass number generated.

6.3.3 Fixed time intervals

For stratified random sampling within fixed time intervals, the procedure is as specified in 6.2 except that, when the time interval has been set, the sample cutter is programmed to take one primary increment at random within this time interval. This is achieved by using a random number generator, capable of giving a random time number within the time interval (determined in 6.2.4), which activates the sample cutter at the time corresponding to the time number generated.

7 Sampling from moving streams

7.1 General

The basic requirements, together with typical examples, are described as a guide to the design and operation of sampling and sample-preparation systems for moving streams. These requirements shall be taken into account from the early stages of design and engineering, as well as during operation and maintenance of the systems.

This International Standard deals only with sample cutters that take a complete cross-section of the DRI or HBI stream. Sample cutters taking only part of the stream are incorrect in design, and cannot be relied on to provide representative samples, i.e. they may introduce significant bias.

It is not essential to construct or operate the sampling system as a single system. Any principal unit or combination of principal units may be operated mechanically, and combined at any stage with manual sample preparation to form a complete sampling and sample-preparation system.

The sampling system shall be operated according to the requirements of Clauses 5 and 6, which specify the mass of increment, number of increments, and sampling interval for mass-basis, time-basis and stratified random sampling. Operation of the system should be monitored at all times during sampling and sample preparation of a lot. In the event of a breakdown or failure of the installation, the mechanical operation shall be replaced immediately by manual stopped-belt sampling.

Samples taken by stopped-belt sampling should be processed separately from those taken mechanically.

Care shall be taken not to alter the quality of increments, partial samples and gross samples during sampling and sample preparation. In addition, care shall be taken to minimize changes in the quality of a lot after sampling at loading and prior to sampling at discharge. Where water is sprayed on a cargo for dust suppression or where water is removed from a lot, a correction for the water shall be made in accordance with ISO 3087.

7.2 Safety of operations

From the initial stage of design and construction of sampling systems, due consideration shall be given to the safety of operators. Local or national safety codes shall be respected.

It is recommended that mechanical sampling be used if the flow rate exceeds 500 t/h. Unless stopped-belt sampling is adopted, the use of manual sampling in such cases could be dangerous for the sampling staff.

7.3 Robustness of sampling installation

Sampling and sample-preparation systems shall be designed and constructed robustly to fulfil, without failure, their required function under given conditions at all times, particularly for HBI. The system shall also be designed to provide ready access for maintenance.

In the event of a breakdown of the installation, an alternative sampling procedure should be available. For example, increments taken by the primary sampler may be bypassed through a preinstalled facility (e.g., a short conveyor, a concrete pad or a receiving truck) so that manual sample preparation can be performed.

It is recommended that mechanical sampling systems be arranged in such a way that the principal units can be operated individually to facilitate repair in the event of breakdown.

7.4 Versatility of sampling system

The design of sampling and sample-preparation systems shall be

- a) guided by the types of DRI or HBI likely to be handled, the quality characteristics to be determined and the desired precision of sampling and sample preparation, and
- b) such that bias is not introduced.

In all cases, the minimum mass and number of increments comprising a sample shall comply with 5.1.4 and 5.4, respectively, in order to attain the specified precision and the required mass of sample for testing.

The size sample shall be taken before any crushing takes place. Multiple use of increments taken to constitute a sample is permissible, provided that the general procedures given in Clause 4 are fulfilled. If size determination is carried out on a sample that will subsequently be used for other purposes, care shall be taken to ensure that the size fractions are fully remixed before subsequent sample preparation is undertaken.

The installation shall be designed so that check experiments can be carried out in conjunction with routine sampling. Sampling systems should be capable of combining alternate increments to constitute pairs of interleaved samples, designated A and B, for determination of quality variation in accordance with ISO 3084 and for checking the precision of sampling in accordance with ISO 3085. To meet the sampling requirements of ISO 3085, the primary sampler should also be capable of taking at least twice the number of increments, n_1 , specified in 5.4. When these design features are in place, it is recommended that the precision of sampling be determined routinely, in accordance with ISO 3085, as part of the normal sampling operations.

7.5 Primary samplers

7.5.1 Location

The primary sampler shall be installed at a point where the entire lot may be sampled. It should be installed at the nearest point to the loading or discharging facilities, as close as possible to the point of weighing.

7.5.2 Types of primary sampler

There are several types of primary sampler, which vary in mode of operation and shape. The most widely accepted is a cutter-type primary sampler installed at the discharge end of a conveyor belt and designed to collect increments by cutting a complete cross-section of the DRI or HBI stream, travelling through the stream at uniform speed. Increments should preferably be taken from a falling stream using a mechanical sample cutter, although a manual sample cutter may also be used for sampling DRI (but not HBI) if the flow rate does not exceed 500 t/h (see 7.2).

Examples of mechanical cutter-type samplers are shown diagrammatically in Figure 1. An example of a manual sample cutter is shown in Figure 2.

7.5.3 General design criteria for primary cutters

To avoid bias, the primary sampler shall satisfy the following design criteria:

- a) there shall be no overflow or spillage of sample, or loss of fines;
- b) there shall be no impedance to flow of sample material through the sample cutter at the maximum flow rate;
- c) bucket-type cutters shall be of sufficient capacity to accommodate the increment mass obtained at the maximum flow rate of the DRI or HBI;
- d) there shall be no clogging or retention of residual material in the sample cutter, i.e., the cutter shall be self-clearing and chutes shall have suitable linings, e.g. ceramic;
- e) there shall be no contamination or introduction of material other than the sample into the sample cutter;
- f) there shall be no significant change of the quality of the sample while taking increments, e.g., degradation of the constituent particles if the sample is taken for size determination.
- g) the sample cutter shall take a complete cross-section of the DRI or HBI stream, both the leading and trailing edges clearing the stream in one path;
- h) the sample cutter shall intersect the DRI or HBI stream, either in a plane perpendicular to or along an arc normal to the mean trajectory of the stream;
- i) the sample cutter shall travel through the DRI or HBI stream at a uniform speed, not deviating by more than $\pm 5\%$ at any point;
- j) the geometry of the cutter aperture shall be such that the cutting time at each point in the stream is equal, not deviating by more than $\pm 5\%$, e.g., straight-path cutters shall have parallel cutter lips and rotary cutters shall have radial cutter lips;
- k) the plane of the cutter aperture shall not be vertical or near-vertical.

An example of a checklist for mechanical sampling systems is given in Annex A.

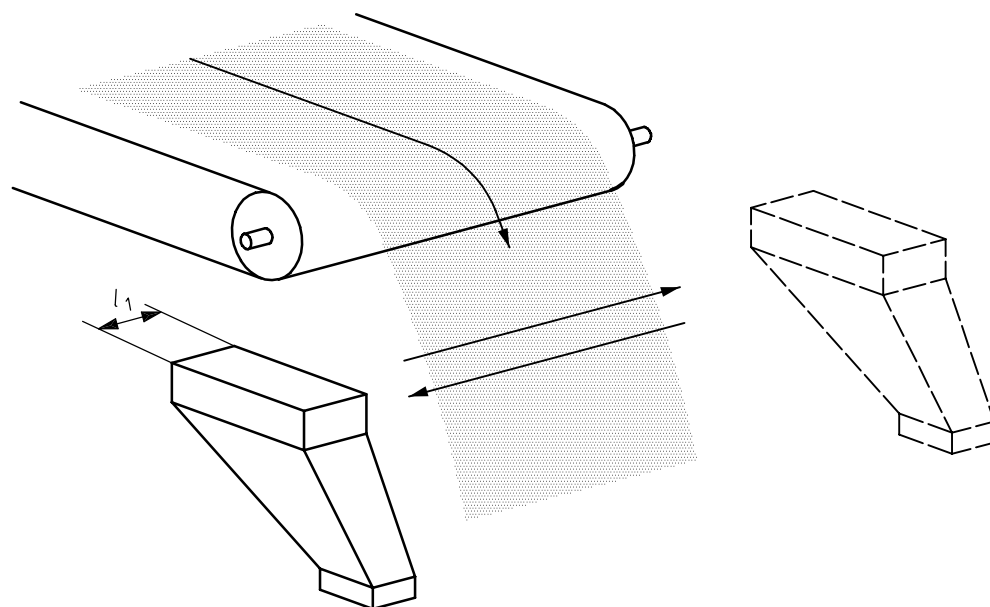

a) Cutter-chute type

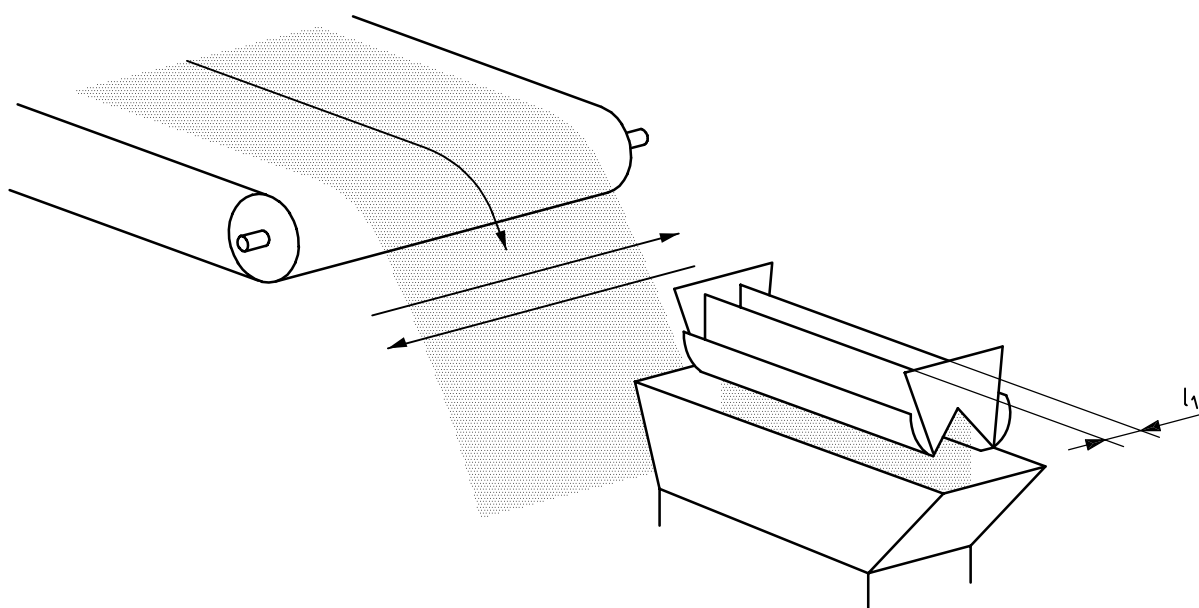

b) Cutter bucket type (i)

Figure 1 — Examples of mechanical cutter-type samplers

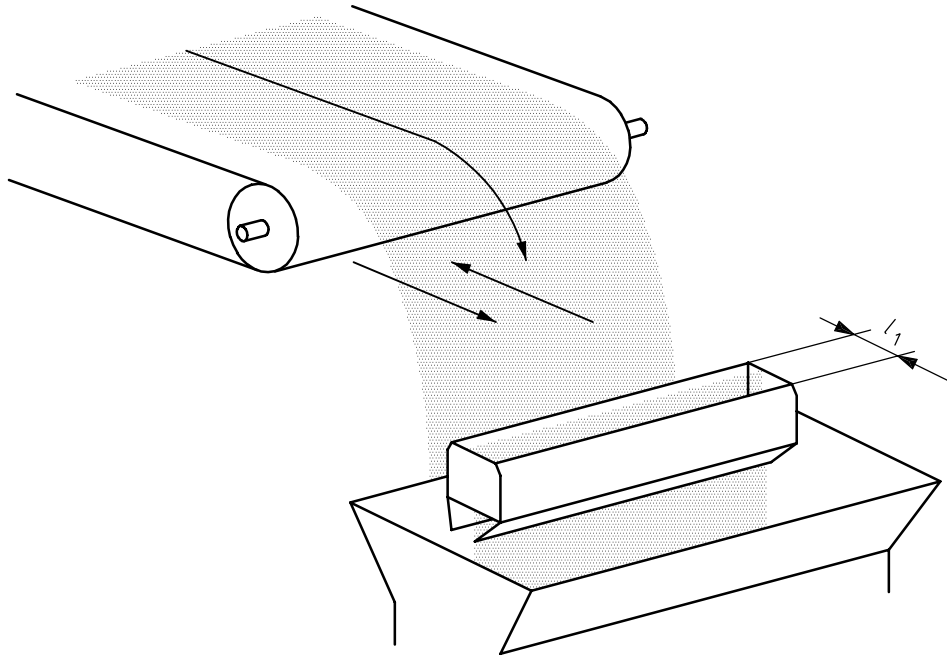

c) Cutter bucket type (ii)

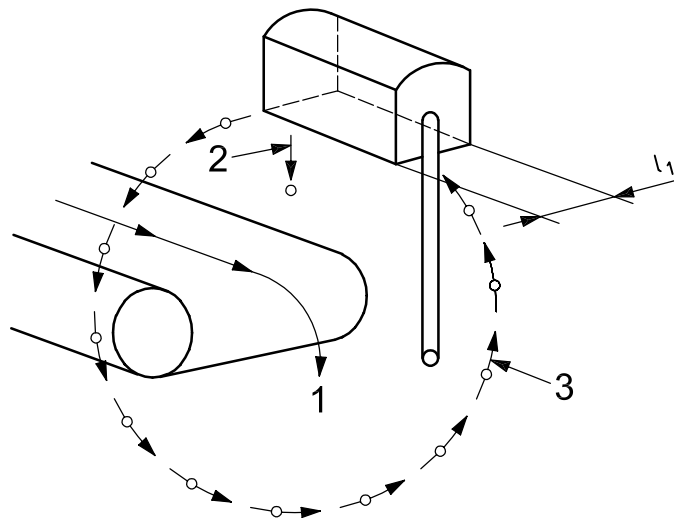

(d1)

d) Swing arm type

Figure 1 (continued)

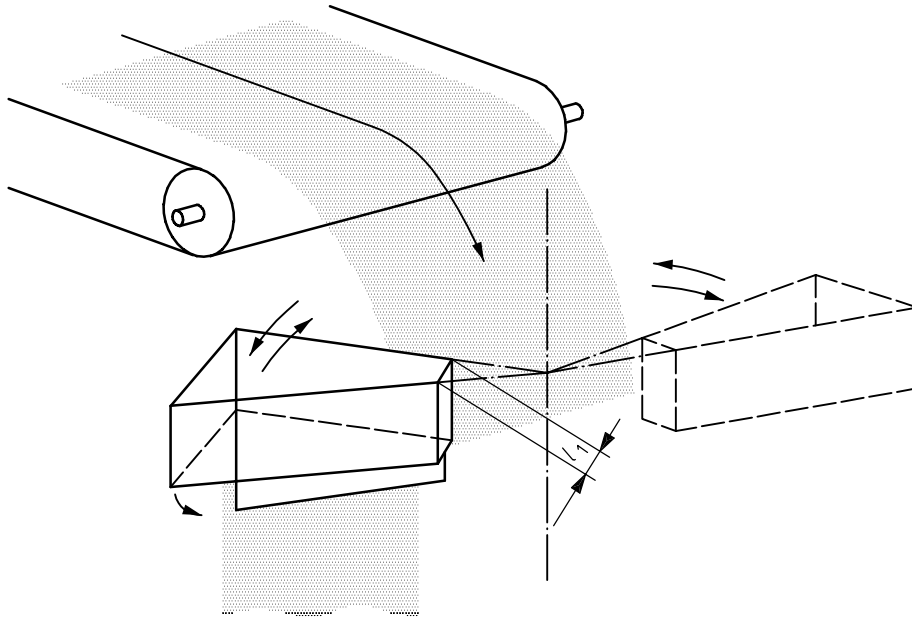

(d2)

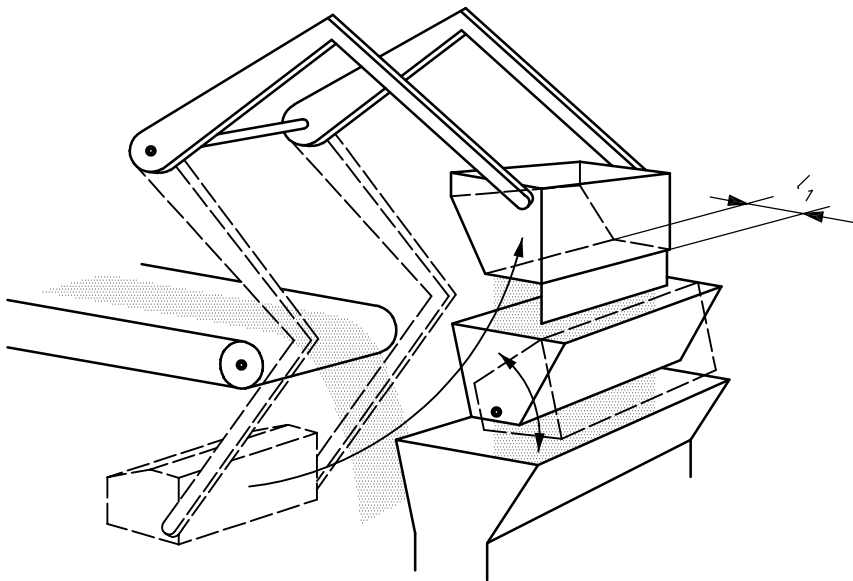

(d3)

d) Swing arm type

Key

- l_1 Cutting aperture of primary sampler.
- 1 main ore flow
- 2 increment
- 3 travelling pass of primary sampler

Figure 1 (continued)

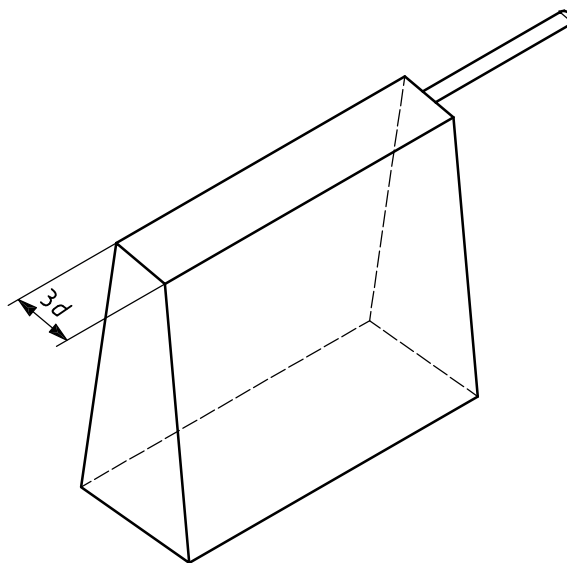

Figure 2 — Example of a manual sample cutter

7.5.4 Cutter aperture of primary sampler

The cutting aperture of the primary sampler (dimension l_1 in Figure 1) shall be at least three times the nominal top size of the DRI or HBI.

7.5.5 Cutter speed of primary sampler

For either of the two kinds of primary samplers mentioned in 6.1.5 or 6.2.5, the cutter shall be designed to travel at a uniform speed, not deviating by more than $\pm 5\%$, during the course of taking each increment.

The cutter speed is one of the most important design parameters in designing a mechanical sampling system. Too high a cutter velocity will lead to

- biasing of the sample due to deflection of the larger particles;
- biasing of the sample by rebounding particles and dust caused by excessive turbulence, and
- shock load problems and difficulties in maintaining constant speed while cutting the stream.

Experimental work undertaken by Gy¹⁾ for falling-stream cutters shows that, when sampling heterogeneous ore streams at low belt loading where the particle-size distribution is very narrow, significant bias may be introduced when the cutter speed exceeds 0,6 m/s or the cutter aperture is less than three times the nominal top size of the ore.

Based on this evidence, cutters that have a cutter aperture (l_1) equal to three times the nominal top size of the DRI or HBI shall not exceed a cutter speed of 0,6 m/s, so that significant bias is not introduced.

For cutters where the effective aperture (l_1) is in excess of three times the nominal top size (d), the maximum cutter speed allowed (v_C) can be increased in accordance with the following equation, subject to a maximum of 1,5 m/s:

$$v_C = 0,3 \left(1 + \frac{l_1}{3d} \right) \quad (15)$$

1) Gy, P. *Sampling of particulate materials — Theory and Practice*. Amsterdam: Elsevier, 1982.

Cutter speeds in excess of the values specified above shall not be used, unless a bias test conducted in accordance with ISO 3086 proves that no significant bias is introduced.

7.6 Secondary and subsequent samplers

The requirements for design and operation of secondary and subsequent samplers are identical to those for primary samplers specified in 7.5.2 to 7.5.5.

The aperture of the sample cutter shall be at least three times the nominal top size of the DRI or HBI, or 10 mm, whichever is the greater.

7.7 On-line sample preparation

7.7.1 Arrangement for sample preparation

The sample-preparation plant shall be designed to carry out preparation of individual increments, individual partial samples or gross samples, in accordance with the requirements given in Clause 10. The system for handling primary increments, from the primary sampling station to that stage of the sample-preparation system where size testing is undertaken, or where size and other physical test samples are taken, shall be carefully designed to avoid severe handling that could cause size degradation of the DRI or HBI sample. The number of transfer points, and the height of fall at each transfer point, shall be kept to a minimum.

Sampling and sample-preparation installations may be either integrated or separate. For an integrated layout, the sample-preparation installation shall be capable of completely processing each increment within the time interval between two consecutive increments taken for the same purpose.

The sample-preparation equipment shall be capable of crushing, grinding and pulverizing the sample to the desired particle size and then dividing the sample to the desired mass without bias. The crushing and dividing equipment shall be appropriately sealed to protect the samples from excessive air flow. The circulation of air through the equipment shall also be reduced to a minimum, in order to prevent loss of fine materials. If it is difficult to incorporate equipment for grinding to minus 160 μm into the sample-preparation system, the grinding operation may be carried out separately.

7.7.2 Crushers

To obtain the desired nominal top size of the sample at each stage of crushing, grinding or pulverizing, the equipment for these processes shall be adjusted so that there will not be any oversize material remaining

7.7.3 Dividers

The following are examples of dividers:

- a) cutter-chute divider [same design as the primary sampler shown in Figure 1 a)];
- b) slotted belt divider [see Figure 3 a)];
- c) chain bucket divider [see Figure 3 b)];
- d) rotary sample divider [see Figure 3 c)];
- e) rotary plate divider [see Figure 3 d)];
- f) rotary cutter-chute divider [see Figure 3 e)].

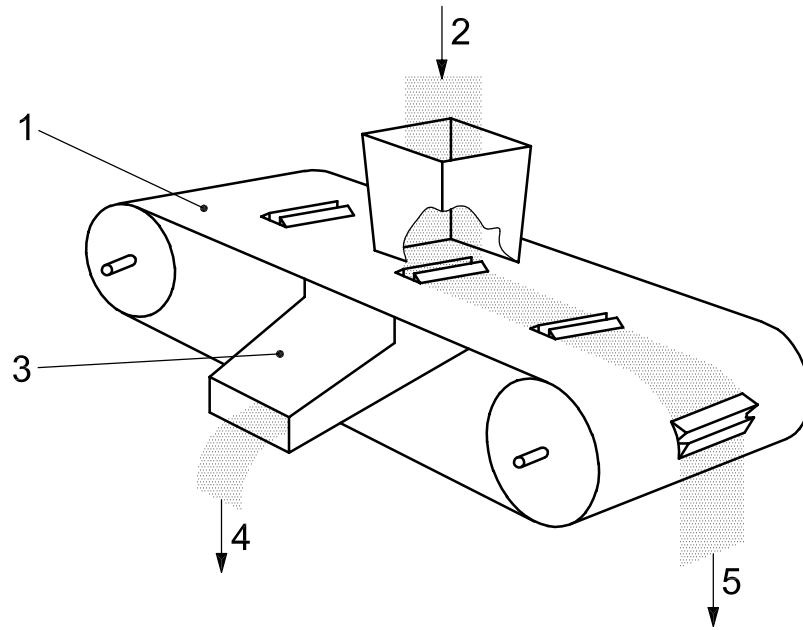
**Key**

- 1 slotted belt
- 2 feed
- 3 inclined chute
- 4 divided sample
- 5 reject

a) Example of slotted belt type divider

Figure 3 — Examples of mechanical dividers

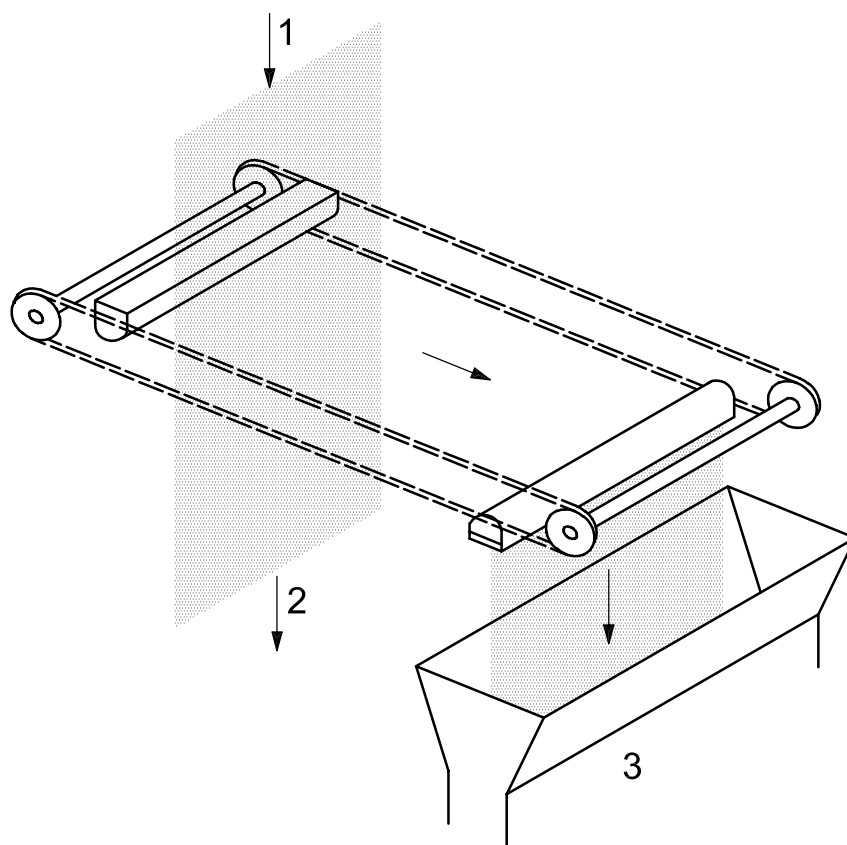

Key

- 1 feed
- 2 reject
- 3 divided sample

b) Example of chain bucket type divider

Figure 3 (continued)

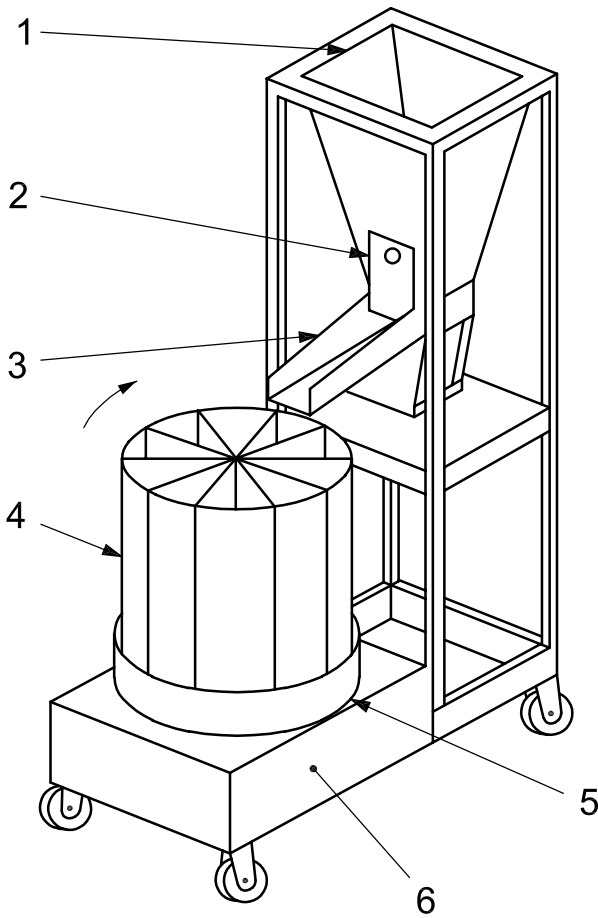

Key

- 1 feed hopper
- 2 slide gate
- 3 vibratory feeder
- 4 removable canisters
- 5 turntable
- 6 drive (enclosed)

c) Example of rotary sample divider

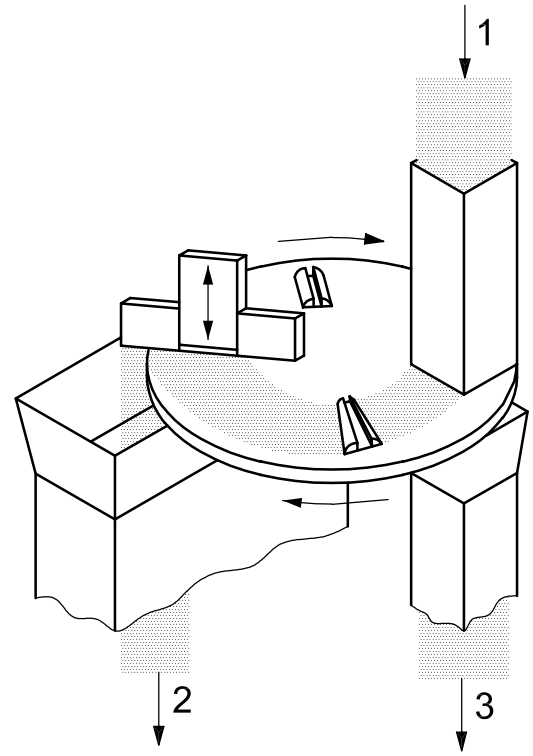

Key

- 1 feed
- 2 reject
- 3 divided sample

d) Example of rotary plate type divider

Figure 3 (continued)

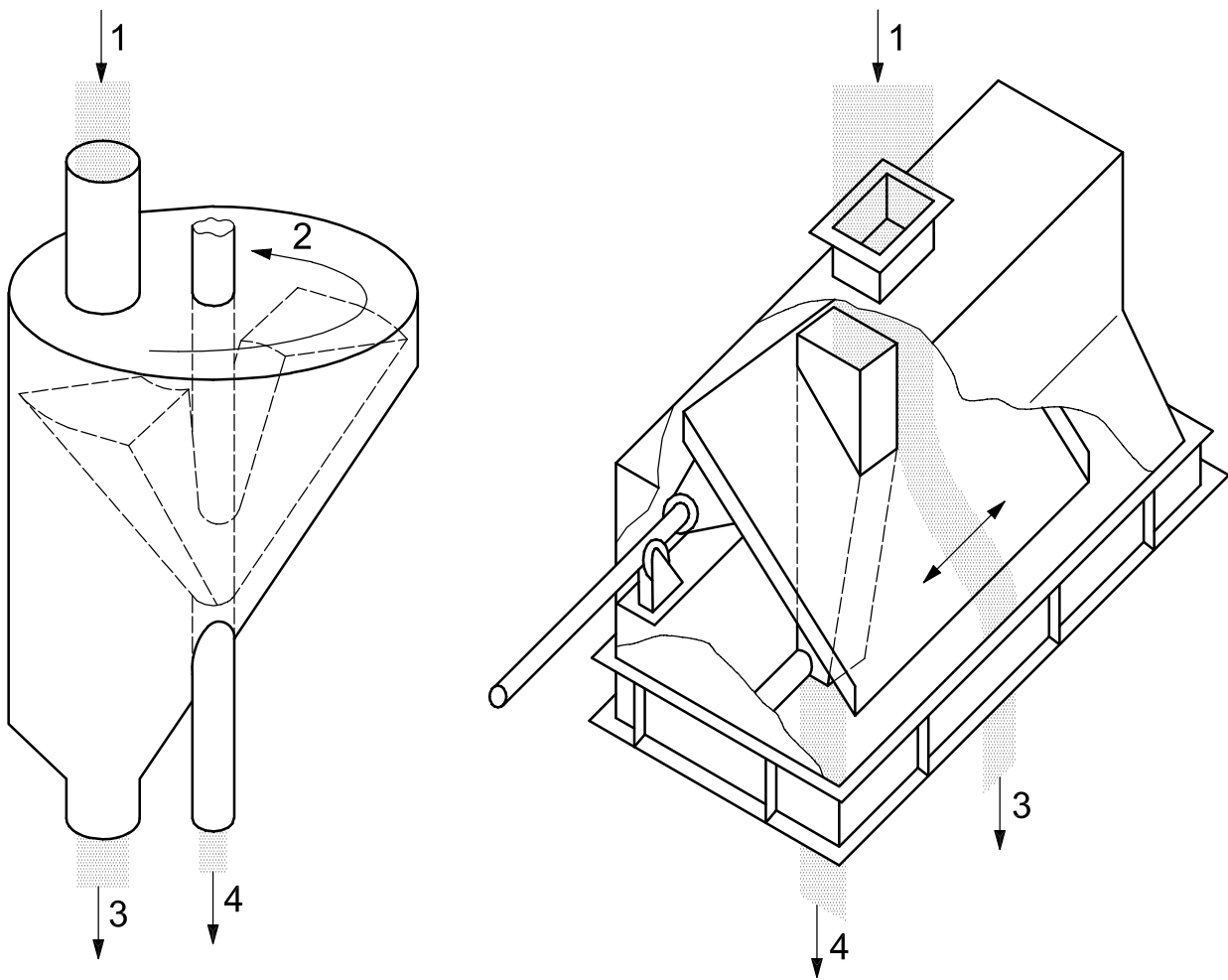

- Key**
- 1 feed
 - 2 rotating hopper
 - 3 reject
 - 4 divided sample

e) Examples of rotary cutter-chute type dividers

Figure 3 (continued)

To avoid bias, the divider shall have a random start. The operation of the cutter should be interlocked with the operation of the feeder via a random timer. The time range of operation of the random selector in the timer shall be adjusted to equal the computed cutting interval, so that there is equal probability of the first cut being taken at any point of time within the duration of the first interval.

Special design precautions are required for the random timer used for constant mass division. Because the cutting interval may be different for each increment or partial sample to be divided, the time range of operation of the random selector in the timer should be manually or automatically adjusted for each successive sample division, to match the computed cutting interval.

If the installation is such that the above requirements cannot be met, then a considerably larger number of cuts than the specified minimum is required to minimize bias.

Licensed copy: Lee Shau Kee Library, HKUST, Version correct as of 03/01/2015, (c) The British Standards Institution 2013

It is recommended that a uniform feed be provided to the divider at each stage of division. The cutter aperture shall be as specified in 7.5.4, and the cutter speed shall be constant (see 7.5.3 and 7.5.5).

7.7.4 Dryers

After the moisture sample has been extracted, a dryer may be used to dry the chemical analysis or physical testing sample so that subsequent sample preparation can be carried out without difficulty. Drying shall be conducted at or below 105°C, because above this temperature there may be a change in the chemical quality of the sample. Care shall also be taken not to introduce other sources of bias, e.g., loss of fines during drying.

7.8 Checking precision and bias

When a sampling installation is newly constructed, when principal parts of the installation are modified, or when a new type of DRI or HBI is being sampled, check experiments for precision (ISO 3085) and bias (ISO 3086) shall be carried out for the installation as a whole, and for each stage when needed. Visual checks shall also be conducted at regular intervals during routine operation, to identify any irregularities in equipment performance. Bias tests should be carried out when these visual checks indicate that there is a problem, or that some other change is suspected. The installation shall be capable of attaining sampling and sample-preparation precision better than those specified in 5.4 and 5.5.

The bias of a sampling installation shall be checked by comparison with “stopped-belt” sampling as specified in Clause 9. Suitable quality parameters for checking bias include total Fe, metallic Fe and apparent density (for HBI).

7.9 Cleaning and maintenance

The sampling system should be readily accessible to facilitate inspection, thorough cleaning, repairs or check experiments.

Upon completion of sampling a lot, the major units of the installation should be cleaned either by using dry and oil-free compressed air, or by using a vacuum system. When a change is made in the type of DRI or HBI being sampled, a quantity of material taken from the lot to be sampled should be passed through the entire installation to remove any possible contaminants.

7.10 Example of a flowsheet

The wide variation in mechanical installations for sampling and sample preparation makes it impracticable to describe a standardized flowsheet. Consequently, only guidelines for constructing a new mechanical installation can be provided. An example of a flowsheet is shown in Figure 4, illustrating the following:

- a) mass-basis sampling;
- b) constitution of a single gross sample from partial samples;
- c) separate preparation of chemical analysis and physical testing samples.

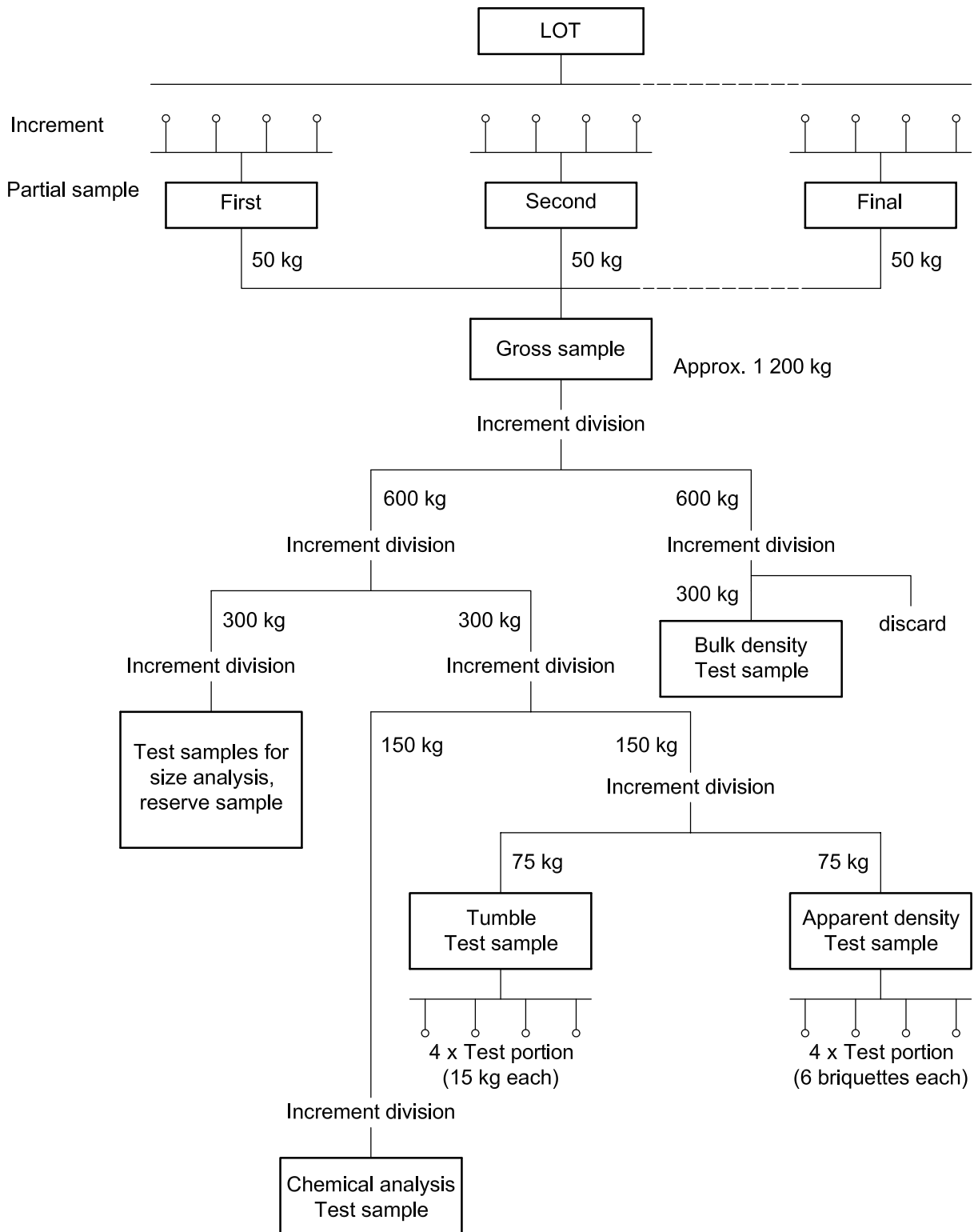

Figure 4 — Example of a sampling and sample-preparation flowsheet

8 Sampling from stationary situations

To avoid bias, it is essential that increments are extracted from the lot, so that all parts of the lot have an equal opportunity of being selected and becoming part of the final sample for analysis. This is not possible for stationary lots of DRI or HBI, because no suitable implement exists that provides access to the full depth of the lot and extracts a full-depth vertical column. Hence, sampling from moving streams when the stationary lot is being moved is the only acceptable method of obtaining representative samples for determining the quality characteristics of the lot.

9 Stopped-belt reference sampling

Stopped-belt sampling is the accepted method for obtaining a reference sample against which other sampling procedures may be compared. The procedure is as follows:

- a) determine the parameters for sampling in accordance with 4.2;
- b) stop the belt at the time or mass intervals determined in accordance with 6.1.4 or 6.2.4;
- c) at each stoppage, place a suitably profiled sampling frame (see Figure 5) with minimum internal dimensions of 3 times the nominal top size of the DRI or HBI across the width of the stationary belt, and insert it through the DRI or HBI so that it is in contact with the belt across its full width (in practice, the internal dimensions of the frame are usually set at 1 m);
- d) should any DRI or HBI particles obstruct insertion of the sampling frame, push those at the left-hand edge of the frame into the increment and those at the right-hand edge of the frame out of the increment;
- e) remove the DRI or HBI within the sampling frame, ensuring that all particles are collected by sweeping the belt clean, and deposit each increment into a suitable container;
- f)
 - 1) if paired comparisons are required on an increment-by-increment basis, keep the increments separate;
 - 2) if the quality of the lot is required, combine the increments into partial samples or a gross sample in accordance with 10.2;
- g) store the increments, partial samples or gross samples in labelled containers as specified in Clause 11.

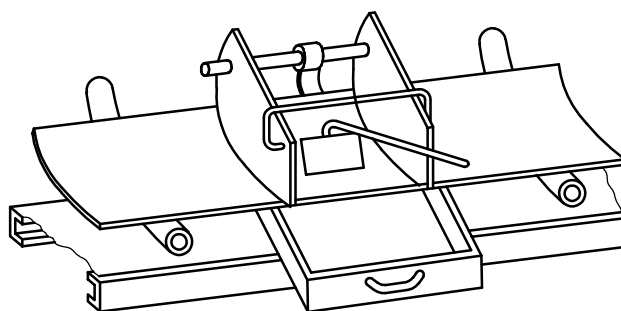

Figure 5 — Example of a sampling frame for use on stopped belts

10 Sample preparation

10.1 Fundamentals

10.1.1 General

Sample preparation is carried out in a number of stages, each stage consisting of a series of crushing, mixing and division operations. The preparation shall be carried out in such a manner that there will be no contamination or introduction of materials other than the sample and no change in its quality.

Check experiments for precision and bias shall be carried out regularly on the sample-preparation process, so that any significant errors in the procedure may be detected.

Sample preparation at the test sample stage may be conducted on each increment, on each partial sample constituted from increments, or on the gross sample constituted from partial samples or increments.

Partial samples are constituted from two or more increments, either as taken or after having been prepared individually to an appropriate stage of division.

The gross sample is constituted from all the increments or partial samples, either as taken or after having been prepared individually to an appropriate stage of division.

An example of a sample-preparation scheme for constituting partial samples from increments and a gross sample from partial samples is shown in Figure 4.

10.1.2 Crushing and grinding

Crushing and grinding shall be conducted with equipment that is suitable for the size and hardness of the DRI or HBI. The crusher and grinder shall be purged with DRI or HBI from the same source. Special care shall be taken not to overgrind the DRI or HBI below a nominal top size of 160 μm , because this may lead to oxidation of the sample. In addition, grinding equipment shall not be allowed to become hot and shall be cooled between samples if necessary.

10.1.3 Mixing

Mixing the sample will make it more homogeneous and consequently the errors in sample division will be reduced. Mixing is particularly important when samples from more than one source are combined. Where possible, the sample-preparation scheme should be designed so that the need for mixing is minimized.

Examples of suitable mixing methods include:

- a) mechanical mixers such as a V-mixer;
- b) passing the sample through a riffle or preferably a rotary sample divider three times in succession, recombining the portions after each pass. Dust losses must be minimized.

NOTE Some methods of hand mixing, for example, forming and reforming a conical pile, can have the opposite effect to that intended, and can lead to increased segregation.

10.1.4 Sample division

10.1.4.1 General

Sample division shall be carried out on the sample, crushed if necessary to an appropriate particle size, to reduce the sample mass.

To obtain the specified precision of sample preparation, the following aspects of division shall be considered:

- a) nominal top size of the sample to be divided;
- b) minimum mass of the sample after division (see 10.1.5), specified for each quality characteristic to be determined.

10.1.4.2 Method of division

One or more of the following methods of sample division shall be conducted individually or jointly:

- a) mechanical increment division (see 10.3.1);
- b) other mechanical-division methods (e.g., mechanically charged riffle divider, see 10.3.2);
- c) manual division (see 10.4).

10.1.4.3 Types of division

When several increments or partial samples are prepared individually and constituted into partial samples or a gross sample, the division of increments or partial samples shall be conducted either by constant-mass division or by proportional division subject to the conditions set out in 10.2.1 and 10.2.2.

10.1.4.4 Types of divider

Acceptable types of mechanical dividers include cutter-chute, slotted belt, chain bucket, rotary container, rotary plate, rotary cutter-chute and mechanically charged riffle (see 10.3.2).

10.1.5 Mass of divided sample

10.1.5.1 Division of moisture and chemical analysis sample

10.1.5.1.1 Division of gross sample

When a gross sample is divided, the minimum mass of the divided sample shall be in accordance with Table 4. The gross sample shall not be divided further than the mass given in Table 4 for the nominal top size of the sample until it is crushed to a smaller particle size, subject to an absolute minimum of 500 g to satisfy the requirements for preparation of test samples for chemical analysis (see 10.7).

Table 4 — Examples of minimum mass of divided gross sample for moisture determination and/or chemical analysis

| Nominal top size of DRI or HBI mm | Minimum mass of divided gross sample kg |
|--------------------------------------|--|
| 100 | 1 600 |
| 63,5 | 500 |
| 40 | 160 |
| 31,5 | 90 |
| 22,4 | 38 |
| 10 | 5 |
| 6,3 | 1,6 |
| 2,8 | 0,5 |
| 1,4 | 0,5 |
| 0,500 | 0,5 |
| 0,250 | 0,5 |

NOTE The minimum masses are indicative and subject to confirmation through international tests.

10.1.5.1.2 Division of individual increments or partial sample

When increments or partial samples are divided, the division shall be carried out ensuring that the mass of the gross sample for the lot obtained by combining divided increments or partial samples shall not be less than the minimum divided-gross-sample mass given in Table 4.

10.1.5.2 Division of physical testing sample

10.1.5.2.1 Division of gross sample

When the gross sample for physical testing is divided, the minimum mass of divided sample shall be in accordance with Table 5.

If the actual percentage of the specified size fraction is considerably different from that in Table 5, the minimum mass of divided gross sample given in Table 5 may need to be increased in accordance with the following equation derived from the binomial rule:

$$m_4 = \frac{m_3 P(100 - P)}{P_0(100 - P_0)} \quad (16)$$

where

m_4 is the revised minimum mass of the divided gross sample to be adopted;

m_3 is the minimum mass of the divided gross sample specified in Table 5;

P is the actual percentage of the size fraction, which is considerably different from that specified in Table 5;

P_0 is the mean percentage of the size fraction

NOTE If the calculated value of the revised minimum mass of divided gross sample, m'_S , is less than the mass, m_S , specified in Table 5, then the mass in Table 5 shall be adopted.

Table 5 — Minimum mass of divided gross sample for physical testing

| Physical test | | Minimum mass of divided gross sample, m_S kg |
|---|-----------------------------------|---|
| Size (– 31,5 + 6,3 mm DRI lump) | – 6,3 mm fraction, mean 10 % | 90 |
| Size (DRI pellets) | – 6,3 mm fraction, mean 5 % | 90 |
| Size (– 100 mm HBI) | – 25 + 6,3 mm fraction, mean 10 % | 800 |
| | – 6,3 mm fraction, mean 10 % | 800 |
| Apparent density | | 150 |
| Tumble and abrasion index | | 60 |
| NOTE The minimum masses are indicative and subject to confirmation through international tests. | | |

10.1.5.2.2 Division of individual increments or partial samples

When increments or partial samples are divided, the division shall be carried out while ensuring that the mass of the gross sample for the lot obtained by combining divided increments or partial samples shall not be less than the minimum divided-gross-sample mass specified in 10.1.5.2.1.

10.1.6 Split use and multiple use of sample

A sample taken from a lot and meeting the specific requirements for determination of several quality characteristics may be subjected to split or multiple use to obtain test samples for moisture determination, physical testing and chemical analysis.

10.2 Method of constituting partial samples or a gross sample

10.2.1 General

According to measurement requirements, a gross sample may be constituted for a lot, or partial samples may be constituted for individual parts of the lot. Furthermore, in some cases, according to sample-preparation requirements, it may be necessary to constitute partial samples first and then constitute a gross sample.

10.2.2 Method of constitution for mass-basis sampling

10.2.2.1 Constitution of partial samples or a gross sample from increments

When the coefficient of variation of increment masses is under 20 %, the increments, either as taken or after having been prepared individually by constant-mass or proportional division to an appropriate stage, may be combined into partial samples or a gross sample.

However, when the coefficient of variation of increment masses is 20 % or over, the increments as taken shall not be combined into partial samples or a gross sample. Individual increments shall first be divided by constant-mass division at a practical stage. The prepared increments may then be combined into partial samples or a gross sample at an appropriate stage.

Alternatively, each increment may be prepared to the test sample stage and subjected to quality determination.

10.2.2.2 Constitution of a gross sample from partial samples

Partial samples constituted in accordance with 10.2.2.1 may be combined into a gross sample.

When division is carried out on each partial sample to constitute a gross sample, division shall be carried out as follows:

- a) if the partial samples consist of an equal number of increments, constant-mass or proportional division shall be used;
- b) if the partial samples consist of different numbers of increments, only proportional division shall be used.

10.2.3 Method of constitution for time-basis sampling

10.2.3.1 Constitution of partial samples or a gross sample from increments

Increments, as taken, may be combined into partial samples or a gross sample, irrespective of the variation of masses of increments. When division is carried out on each increment and the divided increments are combined to constitute partial samples or a gross sample, proportional division shall be used.

10.2.3.2 Constitution of a gross sample from partial samples

Partial samples constituted in accordance with 10.2.2.1 may be combined into a gross sample irrespective of the variation of masses of partial samples.

However, when division is carried out on each partial sample and the divided partial samples are combined to constitute a gross sample, proportional division shall be used.

10.3 Mechanical methods of division

10.3.1 Mechanical increment division

10.3.1.1 General

The chemical analysis and physical testing samples may be divided by mechanical increment division using a cutter-type divider in accordance with the conditions in 10.3.1.2 to 10.3.1.6.

10.3.1.2 Mass of increment (cut)

The mass of each cut shall be uniform. In order to achieve this, the flow of sample to be divided shall be uniform and the cutting aperture and speed of the cutter shall be constant.

NOTE Alternatively, a combination of variable feed rate of sample and variable cutter speed may be considered for taking a uniform cut.

The cutting aperture shall be at least 3 times the nominal top size of the DRI or HBI sample to be divided.

10.3.1.3 Number of increments (cuts)

The number of cuts, n_i , for division of increments, partial samples and gross samples should be determined experimentally from the quality variation, σ_{W_i} , of the stream to be divided and the required sampling precision, β_{S_i} , for the particular sampling stage, i , using the following equation:

$$n_i = \left(\frac{2\sigma_{W_i}}{\beta_{S_i}} \right)^2 \quad (17)$$

However, if no information is available on the quality variation for the particular sampling stage, the following number of cuts may be used as a starting point.

- a) Division of a gross sample:
 - a minimum of 20.
- b) Division of individual partial samples:
 - for constant-mass division, a minimum of 10;
 - for proportional division, a minimum of 10 for the average mass of partial sample.
- c) Division of individual increment
 - for constant-mass division, a minimum of four;
 - for proportional division, a minimum of five for the average mass of increment.

10.3.1.4 Interval between cuts

When constant-mass division is used, the interval between cuts shall be varied according to the mass of the sample to be divided.

When proportional division is applied, the interval between cuts shall be constant, irrespective of the variation of masses of samples to be divided.

10.3.1.5 Avoiding bias

To avoid bias, the first cut for each sample to be divided shall be taken at a random position within the first interval.

10.3.1.6 Mass of divided sample

The minimum mass of divided sample shall conform to the requirements of 10.1.5.

10.3.2 Other mechanical-division methods

10.3.2.1 General

The physical testing sample, moisture sample and sample for chemical analysis may be divided using mechanical dividers other than cutter-type dividers, e.g. a mechanically charged riffle.

10.3.2.2 Mass of divided sample

The minimum mass of divided sample shall conform to the requirements of 10.1.5.

10.4 Manual methods of division

10.4.1 Manual increment division

10.4.1.1 General

Manual increment division can only be applied to DRI or crushed HBI of less than 40 mm nominal top size. Division shall be carried out using an increment division scoop of the type and dimensions shown in Figure 6 and Table 6. The scoop shall be constructed from stainless steel and shall be non-magnetic.

10.4.1.2 Mass of increment

The increment masses shall be approximately equal and shall be as specified in Table 6.

10.4.1.3 Mass of increment

The increment masses shall be approximately equal and shall be as specified in Table 6.

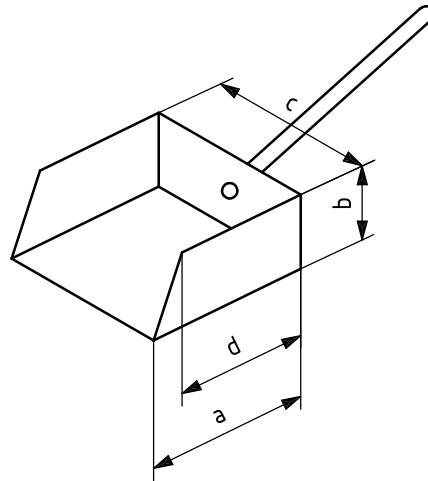

Figure 6 — Example of an increment scoop

Table 6 — Nominal top size, thickness of spread sample, scoop dimensions and increment mass for manual increment division

| Nominal top size | | Thickness of spread sample mm | Scoop number | Dimensions of increment scoop | | | | Increment mass kg |
|------------------|-------|----------------------------------|--------------|-------------------------------|----------|----------|----------|----------------------|
| mm | mm | | | mm | mm | mm | mm | |
| Over | Up to | | | <i>a</i> | <i>b</i> | <i>c</i> | <i>d</i> | |
| 22,4 | 40 | 80 | 31,5D | 180 | 120 | 180 | 150 | 4,5 |
| 10 | 22,4 | 50 | 22,4D | 120 | 100 | 120 | 100 | 1,8 |
| 6,3 | 10 | 30 | 10D | 75 | 40 | 75 | 60 | 0,25 |
| 2,8 | 6,3 | 20 | 6,3D | 50 | 30 | 50 | 40 | 0,08 |
| 1 | 2,8 | 15 | 2,8D | 40 | 25 | 40 | 30 | 0,05 |
| | 1 | 10 | 1D | 25 | 20 | 25 | 20 | 0,015 |

10.4.1.4 Number of increments

The number of increments for manual increment division shall be as specified in Table 7.

Table 7 — Number of increments for manual increment division

| Sample type | Number of manual increments |
|-------------------|-----------------------------|
| Gross sample | 20 |
| Partial sample | 12 |
| Primary increment | 4 |

10.4.1.5 Mass of divided sample

The minimum mass of divided sample shall conform to the requirements of 10.1.5.

10.4.1.6 Procedure

Manual increment division method shall be carried out as follows.

- a) Spread the sample to be divided on a smooth flat plate (non-moisture absorbing) in the form of a rectangle with uniform sample thickness as specified in Table 6.
- b) Mark a matrix on the spread sample, dividing it into the number of parts corresponding to the minimum number of increments specified in Table 7.
- c) Select an appropriate scoop from Table 6, according to the nominal top size of the DRI or crushed HBI to be divided, and collect one increment of approximately equal mass from each part of the matrix (the location being selected at random in each part).
- d) Insert a flat bump plate vertically through the spread sample until it comes into contact with the mixing surface. Then thrust the scoop down to the bottom of the sample layer, and take the increment by moving the scoop horizontally until its open end comes into contact with the bump plate, ensuring that all of the ore particles are collected from the top of the mixing surface.
- e) Lift the scoop and bump plate together to ensure that no sample is lost from the scoop, thereby minimizing bias.

When the mass of the divided sample is likely to be smaller than that required for subsequent testing purposes, the mass of the increment and/or the number of increments shall be increased.

Figure 7 illustrates the division of a gross sample by the manual increment division method.

①

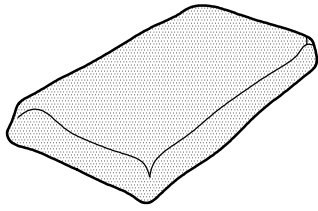

Spread the crushed gross sample into a rectangle with a thickness as specified in Table 6

②

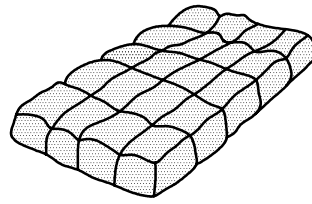

Arrange in 20 equal parts, e.g. into 5 equal parts lengthwise and 4 equal parts breadthwise

③

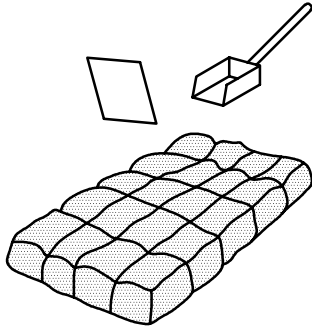

Take a scoopful of sample at random from each of the 20 parts by inserting the scoop to the bottom of the sample layer, and combine the 20 scoops full of sample into a divided sample

Outline of taking an increment by using a bump plate shown in ③

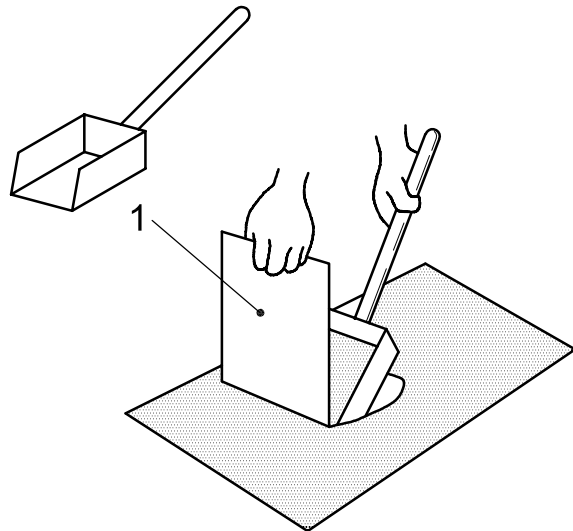

Key

1 bump plate

Figure 7 — Example of manual increment division of a gross sample (20 parts)

10.4.2 Fractional shoveling

10.4.2.1 General

Division by fractional shoveling is applicable to DRI, HBI briquettes and crushed HBI.

10.4.2.2 Number of increments

The number of increments for division using fractional shovelling shall be as specified in 10.3.1.3.

10.4.2.3 Mass of divided sample

The minimum mass of divided sample shall conform to the requirements of 10.1.5.

10.4.2.4 Procedure

Fractional shovelling shall be carried out as follows:

- a) Mix the DRI or HBI, and form a conical heap on a smooth clean surface;
- b) Take successive shovelfuls from the base of the heap, working around the base until the whole conical heap has been redistributed, by placing the shovelfuls on separate heaps. The number of heaps is determined by the division ratio, e.g. if a 1 in 5 division ratio is required, five heaps, N_1 , N_2 , N_3 , N_4 and N_5 , are formed as shown in Figure 8. The number of shovelfuls (increments) placed on each heap shall conform to the requirements of 10.3.1.3.
- c) Select at random the heap to be retained.

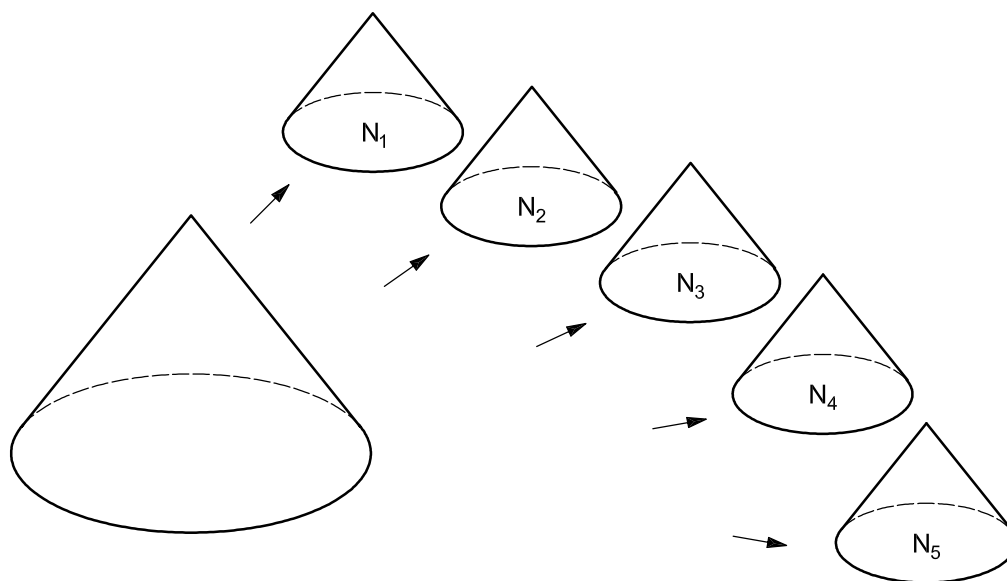

Figure 8 — Example of manual division using fractional shovelling

10.4.3 Manual riffle division method

10.4.3.1 General

Manual riffle division is applicable to DRI or crushed HBI not exceeding 22,4 mm nominal top size. It shall be carried out in accordance with the procedures specified below.

10.4.3.2 Selection of riffle divider

An appropriate riffle divider specified in Table 8 shall be selected to match the nominal top size of the DRI or crushed HBI. Details on the dimensions and design of riffles can be found in Annex C.

Table 8 — Nominal top size of sample and size of riffle divider

| Nominal top size mm | | Riffle-divider number | Riffle opening mm |
|------------------------|---------------------|-----------------------|----------------------|
| Over | Up to and including | | |
| 16,0 | 22,4 | 50 | 50 ± 1 |
| 10,0 | 16,0 | 30 | 30 ± 1 |
| 5,00 | 10,0 | 20 | 20 ± 1 |
| 2,80 | 5,00 | 10 | 10 ± 0,5 |
| | 2,80 | 6 | 6 ± 0,5 |

10.4.3.3 Mass of divided sample

The minimum mass of divided sample shall conform to the requirements of 10.1.5.

10.4.3.4 Procedure

Place the sample to be divided in a container after mixing, and divide it into two by dropping the sample uniformly, with gentle shaking of the container, into the middle of the riffles (at right angles to the riffle). One of the two divided samples should be selected at random, in order to avoid introducing any bias.

Care shall be taken not to leave any material remaining in the slots of the riffle divider.

10.5 Preparation of test sample for physical testing

Each increment, each partial sample or the gross sample taken for size determination, or the divided sample obtained by division of the size sample without crushing, shall be used, and size determination shall be carried out in accordance with the method specified in ISO 4701.

Each increment, each partial sample or the gross sample taken for other physical tests, such as apparent density, tumble index and abrasion index, shall be used, and physical testing shall be carried out in accordance with the relevant International Standard.

10.6 Preparation of test sample for moisture determination

In mass-basis sampling, the test sample for moisture determination may be taken from each increment, each partial sample or the gross sample. In time-basis sampling, the test sample should be taken from each partial sample or the gross sample, to ensure that the specified mass is obtained.

The moisture sample shall be kept in an airtight, non-absorbent container to avoid any change in moisture prior to determination of moisture content in accordance with ISO 3087.

If necessary, the moisture sample shall be crushed to either – 31,5 mm, – 22,4 mm or – 10 mm, as specified in ISO 3087. The first stage of division shall be carried out in accordance with the rules of division specified in 10.3 or 10.4. Then, to obtain a test sample of 10 kg minimum for – 31,5 mm, 5 kg minimum for – 22,4 mm, or 1 kg minimum for – 10 mm particle size, one of the methods of division specified in 10.1.4.2 shall be used. As specified in ISO 3087, the minimum mass of divided sample given in Table 4 and calculated by Equation (16) no longer applies.

Preparation of test samples for moisture determination shall be carried out carefully, but quickly, to avoid moisture evaporation. The remainder of the sample may be used for preparation of a sample for chemical analysis.

NOTE 1 Instead of preparing one test sample of 10 kg minimum at – 31,5 mm, two test portions, of 5 kg minimum each, may be prepared by dividing the test sample of 10 kg minimum into two parts.

NOTE 2 A check is recommended to determine whether the – 10 mm test sample is biased with respect to the – 22,4 mm or – 31,5 mm test sample.

It is recommended that moisture test samples be prepared by manual increment division specified in 10.4.1 to minimize moisture evaporation. A scoop number, one or two ranks smaller than that specified in Table 6, may be used for this purpose for ores of nominal top size 31,5 mm, 22,4 mm, 10 mm or under. However, the test sample thus obtained must not be used for preparation of a sample for chemical analysis.

The mass of the test sample shall be determined immediately. When the immediate determination of mass is not possible, the sample shall be packed tightly in a moisture-proof container and kept in an environment that has approximately constant temperature and humidity.

The relationship between each increment or partial sample and each part (by mass) of the lot shall be recorded.

The number of test portions for moisture determination should be as specified in Table 9.

Table 9 — Number of test portions for moisture determination

| Preparation of test sample | Number of partial samples per lot | Number of test portions to be tested |
|----------------------------|-----------------------------------|--------------------------------------|
| From gross sample | — | 4 |
| From partial sample | 2 | 4 |
| | 3 to 7 | 2 minimum |
| | ≥ 8 | 1 minimum |
| From increment | — | 1 minimum |

10.7 Preparation of test sample for chemical analysis

10.7.1 Mass and particle size

The nominal top size of the test sample for chemical analysis shall be 160 µm. The preferred method is to prepare test samples for chemical analysis of 100 g from the divided gross sample of 250 µm nominal top size. However, if a grinder of appropriate capacity is utilized, a test sample for chemical analysis of 160 µm nominal top size can be prepared directly from samples coarser than 250 µm nominal top size.

10.7.2 Preparation to – 250 µm

If each increment, each partial sample or the gross sample is ground to – 250 µm in particle size, this shall be carried out by repeating crushing and division according to 10.3 or 10.4. When the division is conducted on an individual increment or partial sample before constitution of a gross sample, the gross sample shall be obtained, at a certain stage of the division, by combining quantities proportional to the mass of the individual increment or partial sample. After drying, if necessary, the sample of – 250 µm particle size shall be ground to a nominal top size of 160 µm.

The mass of the – 250 µm sample shall be sufficient to generate the required number of exchange samples.

10.7.3 Final preparation to – 160 µm

10.7.3.1 Type of grinder

Several types of grinders may be used to grind the sample for chemical analysis to a nominal top size of 160 µm, such as a top grinder, a disc grinder, a pot mill or a vibrating mill. Grinders shall be selected that do not generate excessive heat during the grinding operation. As a guide, grinders shall not be too hot to touch at the end of the grinding operation.

The material of construction of the grinder shall be carefully selected so that the chemical composition of the sample does not change during the grinding operation.

It is recommended that an experiment be carried out, in accordance with ISO 3086, to check whether bias in chemical composition has been introduced by the grinding operation.

10.7.3.2 Dry grinding

The whole of the chemical analysis sample should be ground once to a nominal top size of 160 µm using an appropriate grinder. When the grinding of the sample cannot be carried out once, the sample may be divided into a number of parts for separate grinding. This also reduces the generation of heat during grinding, because grinding times are reduced with smaller charges. After all the divided parts have been ground to a nominal top size of 160 µm, they shall be mixed thoroughly in a suitable mixer. To avoid oxidation of samples after grinding, samples shall not be ground to nominal top sizes below 160 µm. The nominal top size of samples after grinding shall therefore be checked regularly as part of a quality-assurance program, to ensure that they are not being overground.

To ensure that the chemical composition of the sample does not change during grinding operations, one or a number of the following precautions shall be taken:

- a) reducing the grinding time by grinding smaller charges;
- b) use of a single pass, straight-through type of grinding mill;
- c) grinding for the minimum time, e.g. less than 1 min, to attain the required nominal top size;
- d) grinding under an inert atmosphere by gently purging the inside of the grinding bowl with dry nitrogen gas.

In all cases, it is essential that the grinding bowl does not become excessively hot during grinding, i.e. the grinding bowl shall not be too hot to touch. The grinding bowl shall therefore be allowed to cool between grinding operations. Alternatively, the grinding bowl may be cooled during grinding with dry nitrogen gas.

The grinding bowl shall be free of moisture, and no moisture shall be added during the grinding operation.

Grinding by an agate pestle and mortar, hand rolling or other suitable manual methods should be used for reference purposes.

10.7.4 Distribution of samples for chemical analysis

A set of not less than four test samples for chemical analysis, each of 100 g minimum, shall be prepared from the 160 µm sample by an appropriate division method. The test samples to be distributed shall be placed in suitable containers, sealed, and clearly marked in accordance with Clause 11.

One sample shall be provided for the seller, one for the purchaser, one for the arbitrator, and, if required, one is to be held in reserve. The reserve sample shall be retained for 6 months.

10.8 Example of sample-preparation process

An example of a sample-preparation process for moisture samples and samples for chemical analysis is shown in Figure 9.

NOTE The flowchart shown in Figure 9 provides an example of sample preparation, where a partial sample comprises three increments and several partial samples compose a gross sample.

11 Packing and marking of sample

The samples for distribution shall be tightly sealed in airtight containers free of any traces of moisture. The following information should be shown on the label and on a card placed in the container:

- a) type and grade of the DRI or HBI and name of the lot (name of ship or train, etc.);
- b) relevant hazard category;
- c) mass of the lot;
- d) sample number;
- e) place, date and method of sampling;
- f) place and date of sample preparation;
- g) particle size of the sample;
- h) purpose of sampling, e.g. bias test, shipping sample;
- i) any other item (if necessary).

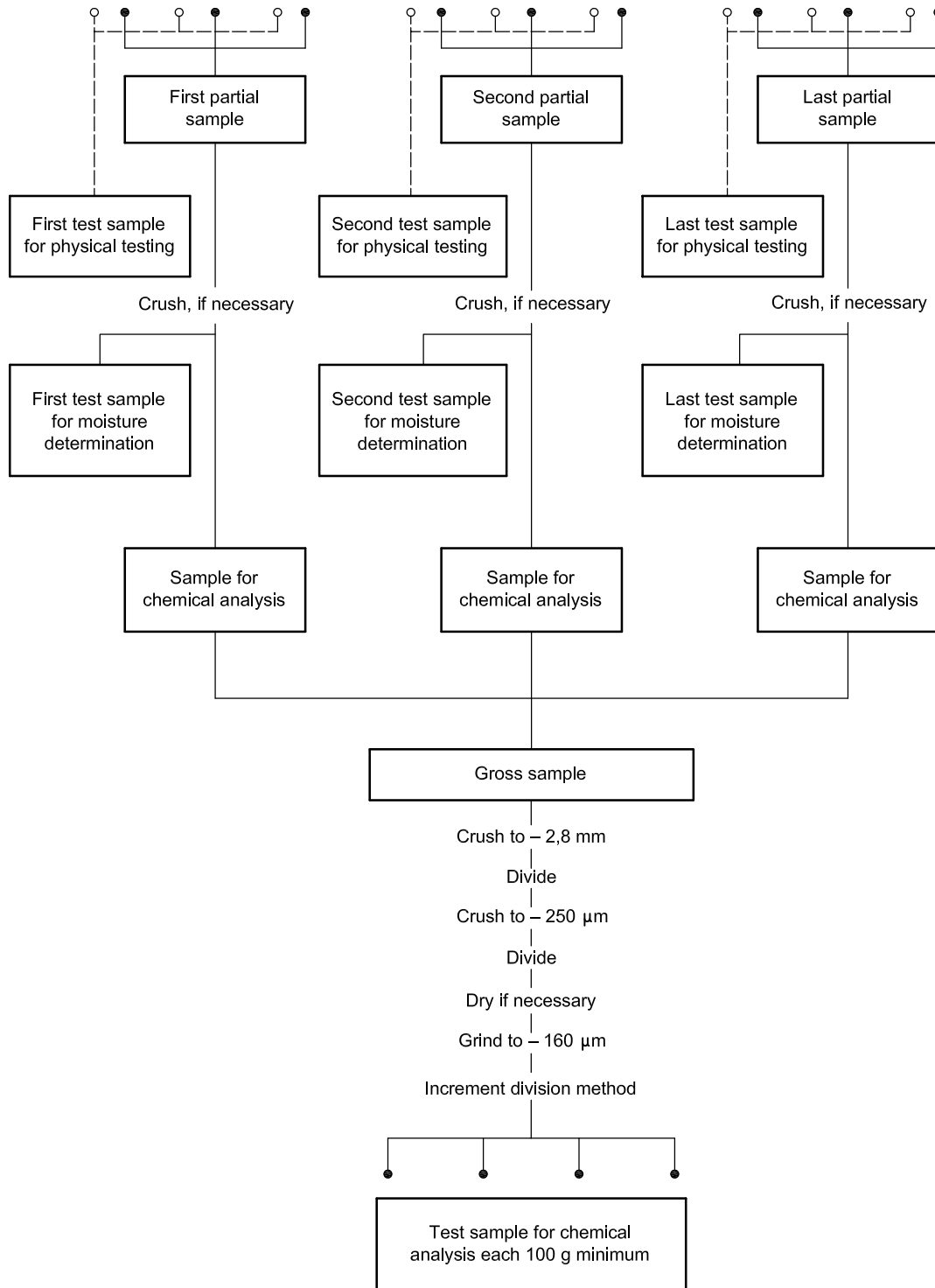

Figure 9 — Example of a sample-preparation scheme for moisture and chemical analysis samples

Annex A (informative)

Inspection of mechanical sampling systems

Table A.1 — Example of a checklist for mechanical sampling systems

Company: _____

Date: _____

Sampler Location & Identification: _____

Inspector: _____

A.1 General Information

- (a) Weather conditions
- (b) DRI or HBI type
- (c) Nominal top size
- (d) Moisture content
- (e) Lot size
- (f) Flow rate (maximum and normal)
- (g) Purpose of sample
- (h) Source of DRI or HBI
- (i) Number of transfer points between sampling point and point of loading/discharge
- (j) Total drop height between sampling point and point of loading/discharge

| Observation | Specification (if applicable) | Tolerance (if applicable) |
|-------------|----------------------------------|------------------------------|
| | | |
| | | |
| | | |
| | | |
| | | |
| | | |
| | | |
| | | |
| | Minimum | |
| | Minimum | |

A.2 Type of Sampling System

Single stage

Two stage

Three stage

A.3 Primary Cutter

- (a) Type of cutter
- (b) Cutter drive
- (c) Nominal top size of DRI or HBI
- (d) Drop height
- (e) Periodicity in DRI or HBI stream
- (f) Cutter aperture
- (g) Condition of cutter lips
- (h) Angle between cutter aperture and stream
- (i) Build-up in cutter aperture and throat
- (j) Unrestricted flow through cutter
- (k) Cutting full stream and belt scrapings
- (l) Cutter speed
- (m) Uniform cutter speed
- (n) Increment mass
- (o) Contamination or loss of sample, including hang-up in chutes and cutter buckets
- (p) Change in moisture content
- (q) Cutter parks out of DRI or HBI stream
- (r) Mass or time-basis sampling
- (s) Interval between cuts
- (t) Number of cuts per lot

| Observation | Specification (if applicable) | Tolerance (if applicable) |
|-------------|----------------------------------|------------------------------|
| | | |
| | | |
| | Minimize | |
| | Minimize | |
| | 3d minimum | |
| | Straight and no significant wear | |
| | Normal | |
| | Not significant | |
| | No choking or reflux | |
| | Full stream cut | |
| | 0,6 m/s max. | ± 5 % |
| | Uniform speed | ± 5 % |
| | | CV < 20 % |
| | Not significant | |
| | Not significant | |
| | Yes | |
| | | |
| | | |
| | | |
| | | |

A.4 Primary Sample Feeder and Chutes

- (a) Type of feeder
- (b) Feed rate
- (c) Tracking of feed conveyors
- (d) Chutes
- (e) Contamination or loss of sample
- (f) Change in moisture content
- (g) Blockages
- (h) Crusher
- (i) Crusher product particle size

| Observation | Specification (if applicable) | Tolerance (if applicable) |
|-------------|----------------------------------|------------------------------|
| | | |
| | | |
| | | |
| | No holes | |
| | Not significant | |
| | Not significant | |
| | Not significant | |
| | | |
| | | |

A.5 Secondary Cutter

- (a) Type of cutter
- (b) Cutter drive
- (c) Nominal top size of DRI or HBI
- (d) Drop height
- (e) Periodicity in DRI or HBI stream
- (f) Cutter aperture
- (g) Condition of cutter lips
- (h) Angle between cutter aperture and stream
- (i) Build-up in cutter aperture and throat
- (j) Unrestricted flow through cutter
- (k) Cutting full stream and belt scrapings
- (l) Cutter speed
- (m) Uniform cutter speed
- (n) Random start for first cut relative to primary cutter
- (o) Increment mass
- (p) Contamination or loss of sample, including hang-up in chutes and cutter buckets
- (q) Change in moisture content
- (r) Cutter parks out of stream
- (s) Interval between cuts
- (t) Number of cuts per primary increment
- (u) Secondary cuts spread out uniformly over the entire primary increment

| Observation | Specification (if applicable) | Tolerance (If applicable) |
|-------------|----------------------------------|------------------------------|
| | | |
| | | |
| | Minimize | |
| | Minimize | |
| | 3d minimum | |
| | Straight and no significant wear | |
| | Normal | |
| | Not significant | |
| | No choking or reflux | |
| | Full stream cut | |
| | 0,6 m/s max. | ± 5 % |
| | Uniform speed | ± 5 % |
| | | |
| | | CV < 20 % |
| | Not significant | |
| | Not significant | |
| | Out of stream | |
| | | |
| | | |
| | | |

A.6 Secondary Sample Feeder and Chutes

- (a) Type of feeder
- (b) Feed rate
- (c) Tracking of feed conveyors
- (d) Chutes
- (e) Contamination or loss of sample
- (f) Change in moisture content
- (g) Blockages
- (h) Crusher
- (i) Crusher product particle size

| Observation | Specification (if applicable) | Tolerance (if applicable) |
|-------------|----------------------------------|------------------------------|
| | | |
| | | |
| | | |
| | No holes | |
| | Not significant | |
| | Not significant | |
| | Not significant | |
| | | |
| | | |

A.7 Tertiary Cutter

- (a) Type of cutter
- (b) Cutter drive
- (c) Nominal top size of DRI or HBI
- (d) Drop height
- (e) Periodicity in DRI or HBI stream
- (f) Cutter aperture
- (g) Condition of cutter lips

- (h) Angle between cutter aperture and stream
- (i) Build-up in cutter aperture and throat
- (j) Unrestricted flow through cutter

- (k) Cutting full stream and belt scrapings
- (l) Cutter speed
- (m) Uniform cutter speed
- (n) Random start for first tertiary cut relative to secondary cutter
- (o) Increment mass
- (p) Contamination or loss of sample, including hang-up in chutes and cutter buckets
- (q) Change in moisture content
- (r) Cutter parks out of stream
- (s) Interval between cuts
- (t) Number of cuts per secondary increment
- (u) Tertiary cuts spread out uniformly over the entire secondary sample

| Observation | Specification (if applicable) | Tolerance (if applicable) |
|-------------|----------------------------------|------------------------------|
| | | |
| | | |
| | | |
| | Minimize | |
| | Minimize | |
| | 3d minimum | |
| | Straight and no significant wear | |
| | Normal | |
| | Not significant | |
| | No choking or reflux | |
| | Full stream cut | |
| | 0,6 m/s max. | ± 5 % |
| | Uniform speed | ± 5 % |
| | | |
| | | CV < 20 % |
| | Not significant | |
| | Not significant | |
| | Out of stream | |
| | | |
| | | |
| | | |
| | | |
| | | |

A.8 Laboratory Sample

- (a) Drop height to container
- (b) Chutes
- (c) Blockages
- (d) Enclosed container
- (e) Nominal top size
- (f) Sample mass
- (g) Change in moisture content

| Observation | Specification (if applicable) | Tolerance (if applicable) |
|-------------|----------------------------------|------------------------------|
| | Minimize | |
| | No holes | |
| | Not significant | |
| | Yes | |
| | | |
| | | |
| | Not significant | |

A.9 General Comments

Annex B (normative)

Equation for number of increments

B.1 Symbols used in the equations

- n_1 is the minimum number of primary increments to be taken from a lot to attain the desired sampling precision.
- β is the precision at the 95 % probability level (or two-sigma probability level) and is twice the standard deviation.
- β_P is the 95 % probability precision of sample preparation.
- β_M is the 95 % probability precision of measurement.
- β_S is the 95 % probability precision of sampling.
- β_{SPM} is the overall precision, i.e., the aggregate 95 % probability precision of sampling, sample preparation and measurement.
- σ is the precision, in terms of the standard deviation.
- σ_P is the precision of sample preparation, in terms of the standard deviation.
- σ_M is the precision of measurement, in terms of the standard deviation.
- σ_S is the precision of sampling, in terms of the standard deviation.
- σ_W is the standard deviation of a quality characteristic within strata (or parts).

B.2 Derivation

The number of primary increments, n_1 , to be taken from a single lot specified in Table 3 is derived from Equation (B.7), the theoretical basis of which is stratified sampling.

From the definition of overall precision at a 95 % probability level, the relationship may be expressed mathematically as follows:

$$\beta_{SPM} = 2\sigma_{SPM} \tag{B.1}$$

or

$$\sigma_{SPM} = \frac{\beta_{SPM}}{2} \tag{B.2}$$

where

$$\sigma_{SPM} = \sqrt{\sigma_S^2 + \sigma_P^2 + \sigma_M^2} \tag{B.3}$$

or

$$\sigma_S = \sqrt{\sigma_{\text{SPM}}^2 - \sigma_P^2 - \sigma_M^2} \quad (\text{B.4})$$

If the lot has been divided into n_3 parts, each of equal tonnage, a test sample has been prepared for each part thus created, and n_2 measurements have been carried out on each test sample to obtain the mean value of the quality characteristic for each part, the following equation should be used for determining the mean value of the quality characteristic of the lot instead of Equation (B.3):

$$\sigma_{\text{SPM}} = \sqrt{\left(\sigma_S^2 + \frac{\sigma_P^2}{n_3} + \frac{\sigma_M^2}{n_3 n_2} \right)}$$

Since the mass of the increment is much smaller than that of the stratum, the finite multiplier in the theoretical equation will become nearly one and the standard deviation of sampling for stratified sampling based on a sample of n_1 primary increments is as follows:

$$\sigma_S = \frac{\sigma_W}{\sqrt{n_1}} \quad (\text{B.5})$$

Therefore

$$\beta_S = 2\sigma_S = \frac{2\sigma_W}{\sqrt{n_1}} \quad (\text{B.6})$$

or

$$n_1 = \left(\frac{2\sigma_W}{\beta_S} \right)^2 \quad (\text{B.7})$$

From equations (B.2), (B.4) and (B.6), the relationship between β_{SPM} and β_S is as follows:

$$\beta_S = 2\sqrt{\left(\frac{\beta_{\text{SPM}}}{2} \right)^2 - \sigma_P^2 - \sigma_M^2} \quad (\text{B.8})$$

If it is not possible to estimate σ_P separately from σ_M , β_S is expressed as follows:

$$\beta_S = 2\sqrt{\left(\frac{\beta_{\text{SPM}}}{2} \right)^2 - \sigma_{\text{PM}}^2} \quad (\text{B.9})$$

NOTE The values of σ_W shown in Table B.1 were used for the calculation of n_1 in Table 3.

Table B.1 — Values of σ_w (absolute percentages)

| Quality characteristics | | Classification of quality variation | | |
|---|--------------------------------------|-------------------------------------|---------|---------|
| | | σ_w | | |
| | | Large | Medium | Small |
| Total iron content | | 1,77 | 1,25 | 0,88 |
| Metallic iron content | | 4,95 | 3,50 | 2,48 |
| Carbon content | | 0,57 | 0,40 | 0,28 |
| Silica content | | 0,57 | 0,40 | 0,28 |
| Alumina content | | 0,57 | 0,40 | 2,28 |
| Phosphorus content | | 0,013 0 | 0,009 0 | 0,006 4 |
| Sulfur content | | 0,013 0 | 0,009 0 | 0,006 4 |
| Moisture content | | 0,57 | 0,40 | 0,28 |
| Size (– 31,5 + 6,3 mm DRI lump) | – 6,3 mm fraction, mean 10 % | 6,250 | 4,375 | 3,125 |
| Size (DRI pellets) | – 6,3 mm fraction, mean 5 % | 3,750 | 2,625 | 1,875 |
| Size (– 100 mm HBI) | – 25 + 6,3 mm fraction, mean 10 % | 1,77 | 1,25 | 0,88 |
| | – 6,3 mm fraction, mean 10 % | 1,77 | 1,25 | 0,88 |
| Apparent density | | 0,57 | 0,40 | 0,28 |
| Tumble index | | 2,50 | 1,75 | 1,25 |
| Abrasion index | | 2,50 | 1,75 | 1,25 |
| NOTE The values of σ_w are indicative and subject to confirmation through international tests. | | | | |

Annex C (normative)

Rifle dividers

Table C.1 — Dimensions of rifle dividers

| Rifle-divider number | | 90 | 60 | 50 | 30 | 20 | 10 | 6 | |
|-----------------------------|-----------------------|-----------------------|--------|--------|--------|--------|--------|----------|---------|
| No. of ruffles ^a | | 12 | 12 | 12 | 12 | 16 | 16 | 16 | |
| Dimensions (mm) | Body | <i>A</i> ^b | 90 ± 1 | 60 ± 1 | 50 ± 1 | 30 ± 1 | 20 ± 1 | 10 ± 0,5 | 6 ± 0,5 |
| | | <i>B</i> | 1120 | 760 | 630 | 380 | 346 | 171 | 112 |
| | | <i>C</i> | 450 | 300 | 250 | 170 | 105 | 55 | 40 |
| | | <i>D</i> | 900 | 600 | 500 | 340 | 210 | 110 | 80 |
| | | <i>E</i> | 500 | 360 | 300 | 200 | 135 | 75 | 60 |
| | | <i>F</i> | 90 | 60 | 50 | 30 | 30 | 20 | 20 |
| | | <i>G</i> | 340 | 340 | 340 | 340 | 210 | 110 | 80 |
| | | <i>H</i> | 300 | 230 | 200 | 140 | 85 | 45 | 30 |
| | | <i>J</i> | 1130 | 770 | 640 | 390 | 360 | 184 | 120 |
| | | <i>K</i> | 300 | 240 | 220 | 220 | 140 | 65 | 55 |
| | Receiver ^c | <i>M</i> | 300 | 240 | 220 | 220 | 140 | 65 | 55 |
| | | <i>N</i> | 340 | 340 | 340 | 340 | 210 | 110 | 80 |
| | | <i>P</i> | 450 | 300 | 250 | 170 | 105 | 55 | 40 |
| | | <i>Q</i> | 110 | 80 | 75 | 55 | 35 | 20 | 15 |
| | | <i>R</i> | 340 | 340 | 340 | 340 | 210 | 110 | 80 |
| | Feeder | <i>S</i> | 1120 | 760 | 630 | 380 | 346 | 171 | 112 |
| | | <i>T</i> | 500 | 400 | 400 | 300 | 200 | 120 | 80 |
| | | <i>U</i> | 335 | 265 | 265 | 200 | 135 | 70 | 45 |
| <i>V</i> | | 300 | 200 | 200 | 150 | 105 | 50 | 35 | |

The inside surface of the divider shall be smooth and free from rust.

^a The number of ruffles shall be even and not less than the number specified in the above table.

^b A is the specified dimension. The other dimensions are shown as examples.

^c The sample receivers shall be fitted tightly to the opening of the divider to avoid scattering of any fine particles.

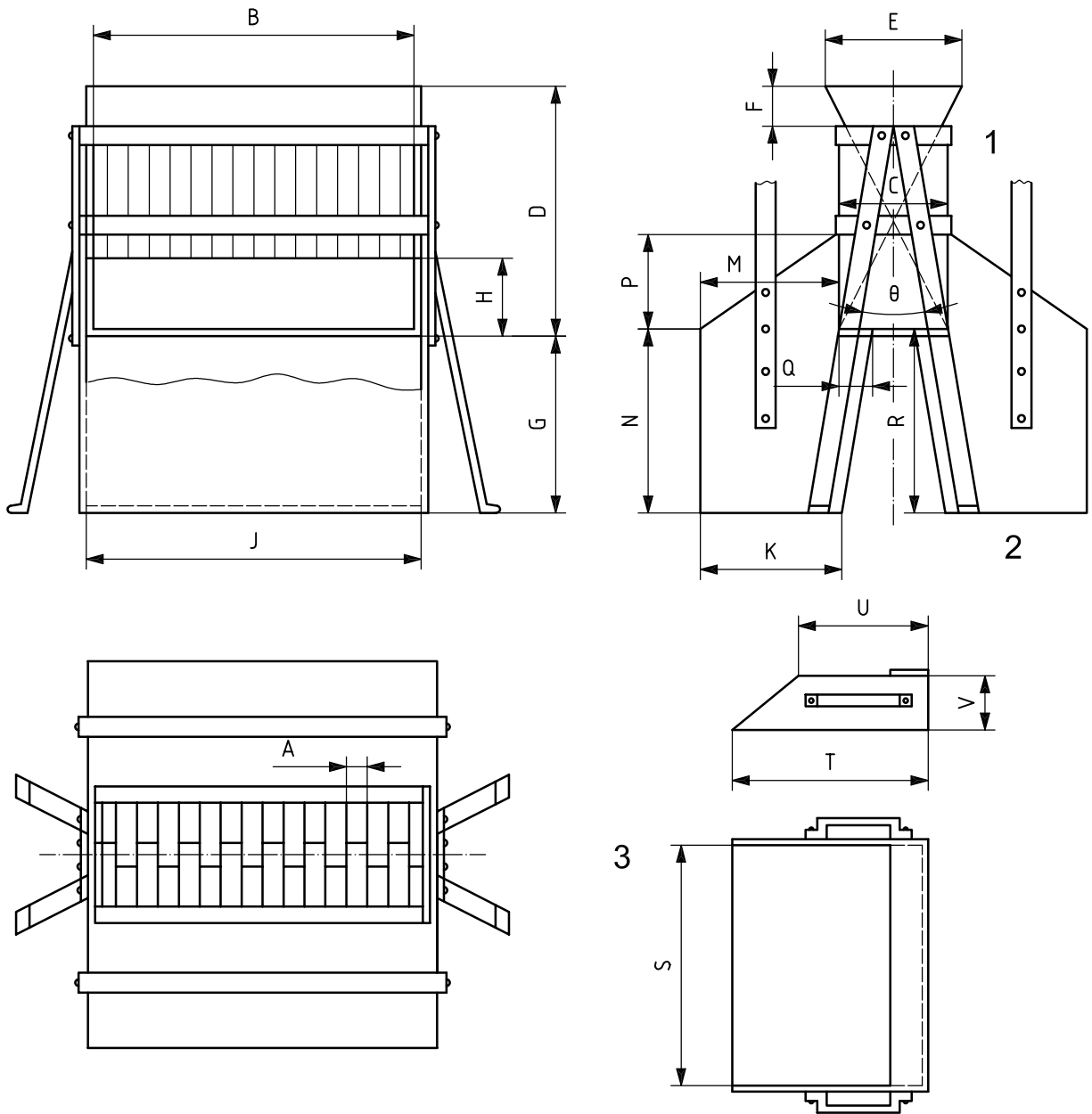

Key

- 1 body
- 2 receiver
- 3 feeder

NOTE θ shall be 60° or less.

Figure C.1 — Example of a riffle divider

BSI — British Standards Institution

BSI is the independent national body responsible for preparing British Standards. It presents the UK view on standards in Europe and at the international level. It is incorporated by Royal Charter.

Revisions

British Standards are updated by amendment or revision. Users of British Standards should make sure that they possess the latest amendments or editions.

It is the constant aim of BSI to improve the quality of our products and services. We would be grateful if anyone finding an inaccuracy or ambiguity while using this British Standard would inform the Secretary of the technical committee responsible, the identity of which can be found on the inside front cover.
Tel: +44 (0)20 8996 9000. Fax: +44 (0)20 8996 7400.

BSI offers members an individual updating service called PLUS which ensures that subscribers automatically receive the latest editions of standards.

Buying standards

Orders for all BSI, international and foreign standards publications should be addressed to Customer Services. Tel: +44 (0)20 8996 9001.
Fax: +44 (0)20 8996 7001. Email: orders@bsi-global.com. Standards are also available from the BSI website at <http://www.bsi-global.com>.

In response to orders for international standards, it is BSI policy to supply the BSI implementation of those that have been published as British Standards, unless otherwise requested.

Information on standards

BSI provides a wide range of information on national, European and international standards through its Library and its Technical Help to Exporters Service. Various BSI electronic information services are also available which give details on all its products and services. Contact the Information Centre.
Tel: +44 (0)20 8996 7111. Fax: +44 (0)20 8996 7048. Email: info@bsi-global.com.

Subscribing members of BSI are kept up to date with standards developments and receive substantial discounts on the purchase price of standards. For details of these and other benefits contact Membership Administration.
Tel: +44 (0)20 8996 7002. Fax: +44 (0)20 8996 7001.
Email: membership@bsi-global.com.

Information regarding online access to British Standards via British Standards Online can be found at <http://www.bsi-global.com/bsonline>.

Further information about BSI is available on the BSI website at <http://www.bsi-global.com>.

Copyright

Copyright subsists in all BSI publications. BSI also holds the copyright, in the UK, of the publications of the international standardization bodies. Except as permitted under the Copyright, Designs and Patents Act 1988 no extract may be reproduced, stored in a retrieval system or transmitted in any form or by any means – electronic, photocopying, recording or otherwise – without prior written permission from BSI.

This does not preclude the free use, in the course of implementing the standard, of necessary details such as symbols, and size, type or grade designations. If these details are to be used for any other purpose than implementation then the prior written permission of BSI must be obtained.

Details and advice can be obtained from the Copyright & Licensing Manager.
Tel: +44 (0)20 8996 7070. Fax: +44 (0)20 8996 7553.
Email: copyright@bsi-global.com.