

BS ISO 10790:2015



BSI Standards Publication

Measurement of fluid flow in closed conduits — Guidance to the selection, installation and use of Coriolis flowmeters (mass flow, density and volume flow measurements)

bsi.

...making excellence a habit.™

National foreword

This British Standard is the UK implementation of ISO 10790:2015. It supersedes BS ISO 10790:1999 which is withdrawn.

The UK participation in its preparation was entrusted to Technical Committee CPI/30/5, Velocity and Mass Methods.

A list of organizations represented on this committee can be obtained on request to its secretary.

This publication does not purport to include all the necessary provisions of a contract. Users are responsible for its correct application.

© The British Standards Institution 2015. Published by BSI Standards Limited 2015

ISBN 978 0 580 78002 8

ICS 17.120.10

Compliance with a British Standard cannot confer immunity from legal obligations.

This British Standard was published under the authority of the Standards Policy and Strategy Committee on 30 April 2015.

Amendments issued since publication

Date	Text affected
------	---------------

**Measurement of fluid flow in closed
conduits — Guidance to the selection,
installation and use of Coriolis
flowmeters (mass flow, density and
volume flow measurements)**

Mesure de débit des fluides dans les conduites fermées — Lignes directrices pour la sélection, l'installation et l'utilisation des mesureurs à effet Coriolis (mesurages de débit-masse, masse volumique et débit-volume)





COPYRIGHT PROTECTED DOCUMENT

© ISO 2015

All rights reserved. Unless otherwise specified, no part of this publication may be reproduced or utilized otherwise in any form or by any means, electronic or mechanical, including photocopying, or posting on the internet or an intranet, without prior written permission. Permission can be requested from either ISO at the address below or ISO's member body in the country of the requester.

ISO copyright office
Case postale 56 • CH-1211 Geneva 20
Tel. + 41 22 749 01 11
Fax + 41 22 749 09 47
E-mail copyright@iso.org
Web www.iso.org

Published in Switzerland

Contents

Page

Foreword	v
Introduction	vi
1 Scope	1
2 Normative references	1
3 Terms and definitions	1
3.1 Definitions specific to this Coriolis flowmeter standard.....	1
3.2 Definitions from VIM, ISO/IEC Guide 99 (JCGM:2012).....	3
3.3 Symbols.....	4
3.4 Abbreviations.....	5
4 Coriolis flowmeter selection criteria	5
4.1 General.....	5
4.2 Physical installation.....	5
4.2.1 General.....	5
4.2.2 Installation criteria.....	6
4.2.3 Full-pipe requirement for liquids.....	6
4.2.4 Orientation.....	6
4.2.5 Flow conditions and straight length requirements.....	6
4.2.6 Valves.....	6
4.2.7 Cleaning.....	6
4.2.8 Hydraulic and mechanical vibrations.....	7
4.2.9 Pipe stress and torsion.....	7
4.2.10 Crosstalk between sensors.....	7
4.3 Effects due to process conditions and fluid properties.....	7
4.3.1 General.....	7
4.3.2 Application and fluid properties.....	7
4.3.3 Multiphase flow.....	8
4.3.4 Influence of process fluid.....	8
4.3.5 Temperature effects.....	8
4.3.6 Pressure effects.....	9
4.3.7 Pulsating flow effects.....	9
4.3.8 Viscosity effects.....	9
4.3.9 Flashing and/or cavitation.....	9
4.4 Pressure loss.....	9
4.5 Safety.....	9
4.5.1 General.....	9
4.5.2 Hydrostatic pressure test.....	9
4.5.3 Mechanical stress.....	10
4.5.4 Erosion.....	10
4.5.5 Corrosion.....	10
4.5.6 Housing design.....	10
4.5.7 Cleaning.....	10
4.6 Transmitter (secondary device).....	10
4.7 Diagnostics.....	11
5 Inspection and compliance	11
6 Mass flow measurement	12
6.1 Apparatus.....	12
6.1.1 Principle of operation.....	12
6.1.2 Coriolis sensor.....	14
6.1.3 Coriolis transmitter.....	15
6.2 Mass flow measurement.....	15
6.3 Factors affecting mass flow measurement.....	17
6.3.1 Density and viscosity.....	17

6.3.2	Multiphase flow	17
6.3.3	Temperature	18
6.3.4	Pressure	18
6.3.5	Installation	18
6.4	Zero adjustment	18
6.5	Calibration of mass flow measurement	18
7	Density measurement	19
7.1	General	19
7.2	Principle of operation	20
7.3	Specific gravity of fluids	21
7.4	Density measurement uncertainty	21
7.5	Factors affecting density measurement	21
7.5.1	Temperature	21
7.5.2	Pressure	22
7.5.3	Multiphase (Two phase)	22
7.5.4	Flow effect	22
7.5.5	Corrosion and erosion	22
7.5.6	Coatings	22
7.5.7	Installation	22
7.6	Density calibration and adjustment	22
7.6.1	General	22
7.6.2	Manufacturer's density calibration	22
7.6.3	Field density calibration and adjustment	23
8	Volume flow measurement at metering conditions	23
8.1	General	23
8.2	Volume calculation	23
8.3	Gas as a process fluid	24
8.4	Volume measurement uncertainty	24
8.5	Special influences	24
8.5.1	General	24
8.5.2	Empty pipe effect	24
8.5.3	Multiphase fluids	24
8.6	Factory calibration	24
8.6.1	Mass flow and density	24
8.7	Volume check	25
	Annex A (informative) Calibration techniques	26
	Annex B (informative) Safety guidelines for the selection of Coriolis flowmeters	29
	Annex C (informative) Considerations for multi-component liquid systems	31
	Annex D (informative) Miscible liquids containing chemically non-interacting components	34
	Bibliography	37

Foreword

ISO (the International Organization for Standardization) is a worldwide federation of national standards bodies (ISO member bodies). The work of preparing International Standards is normally carried out through ISO technical committees. Each member body interested in a subject for which a technical committee has been established has the right to be represented on that committee. International organizations, governmental and non-governmental, in liaison with ISO, also take part in the work. ISO collaborates closely with the International Electrotechnical Commission (IEC) on all matters of electrotechnical standardization.

The procedures used to develop this document and those intended for its further maintenance are described in the ISO/IEC Directives, Part 1. In particular the different approval criteria needed for the different types of ISO documents should be noted. This document was drafted in accordance with the editorial rules of the ISO/IEC Directives, Part 2 (see www.iso.org/directives).

Attention is drawn to the possibility that some of the elements of this document may be the subject of patent rights. ISO shall not be held responsible for identifying any or all such patent rights. Details of any patent rights identified during the development of the document will be in the Introduction and/or on the ISO list of patent declarations received (see www.iso.org/patents).

Any trade name used in this document is information given for the convenience of users and does not constitute an endorsement.

For an explanation on the meaning of ISO specific terms and expressions related to conformity assessment, as well as information about ISO's adherence to the WTO principles in the Technical Barriers to Trade (TBT), see the following URL: [Foreword — Supplementary information](#).

The committee responsible for this document is ISO/TC 30, *Measurement of fluid flow in closed conduits*, Subcommittee SC 5, *Velocity and mass methods*.

This third edition cancels and replaces the second edition (ISO 10790:1999), which has been technically revised. It also incorporates the Amendment ISO 10790:1999/Amd 1:2003.

Introduction

This International Standard has been prepared as a guide for those concerned with the selection, testing, inspection, operation, and calibration of Coriolis flowmeters (Coriolis flowmeter assemblies). A list of related International Standards is in the Bibliography.

This International Standard provides the following:

- a) description of the Coriolis operating principle;
- b) guideline to expected performance characteristics of Coriolis flowmeters;
- c) description of calibration, verification, and checking procedures;
- d) description of potential error sources;
- e) common set of terminology, symbols, definitions, and specifications.

The next paragraphs contain an explanation of when to use the measurement terminology, uncertainty, and accuracy.

The VIM definition (see [3.2](#)) of accuracy: closeness of agreement between a measured quantity value and a “true quantity value” of a measurand. Per the VIM, accuracy is a quality and should not be given a numerical value.

To understand the preceding paragraph, one needs to understand that a “true quantity value” does not exist. The best that can be done is to determine the measured quantity value with measurement instrumentation calibrated with a very good but imperfect reference. Therefore, the measurement is an estimate. Uncertainty is used to define these measurement estimates (see [3.2.2](#)).

Many Coriolis manufacturers use accuracy and zero stability as part of their published performance specifications. The manufacturer’s accuracy specification includes repeatability, hysteresis, and linearity but can also include other items that might be different for each manufacturer.

This International Standard will use uncertainty to quantify the results of a flow measurement system. This International Standard will only use accuracy when it is very clear that it is referring to or using all or part of the manufacturers published specifications.

Measurement of fluid flow in closed conduits — Guidance to the selection, installation and use of Coriolis flowmeters (mass flow, density and volume flow measurements)

1 Scope

This International Standard gives guidelines for the selection, installation, calibration, performance, and operation of Coriolis flowmeters for the measurement of mass flow and density. This International Standard also gives appropriate considerations regarding the type of fluids measured, as well as guidance in the determination of volume flow and other related fluid parameters.

NOTE Fluids defined as air, natural gas, water, oil, LPG, LNG, manufactured gases, mixtures, slurries, etc.

2 Normative references

The following documents, in whole or in part, are normatively referenced in this document and are indispensable for its application. For dated references, only the edition cited applies. For undated references, the latest edition of the referenced document (including any amendments) applies.

ISO 5168, *Measurement of fluid flow — Procedures for the evaluation of uncertainties*

ISO/IEC 17025, *General requirements for the competence of testing and calibration laboratories*

ISO/IEC Guide 99:2007 (JCGM 200:2012), *International vocabulary of metrology — Basic and general concepts and associated terms (VIM)*

3 Terms and definitions

3.1 Definitions specific to this Coriolis flowmeter standard

For the purposes of this document, the following terms and definitions apply.

3.1.1

Coriolis flowmeter

device consisting of a flow sensor (primary device) and a transmitter (secondary device) which measures mass flow and density by means of the interaction between a flowing fluid and the oscillation of a tube or tubes

Note 1 to entry: This can also provide measurement of the tube(s) temperature.

3.1.2

flow sensor (primary device)

mechanical assembly consisting of an oscillating tube(s), drive system, measurement sensor(s), supporting structure, and housing

3.1.3

transmitter (secondary device)

electronic control system providing the drive electrical supply and transforming the signals from the flow sensor to give output(s) of measured and inferred parameters

Note 1 to entry: It also provides corrections derived from parameters such as temperature.

Note 2 to entry: The transmitter (secondary device) is either integrally mounted (compact device) on the flow sensor (primary device) or remotely installed away from the primary device and connected by a cable.

3.1.4

oscillating tube

tube through which the fluid to be measured flows

3.1.5

drive system

means for inducing the oscillation of the tube(s)

3.1.6

sensing device

sensor to detect the effect of the Coriolis force and to measure the frequency of the tube oscillations

3.1.7

supporting structure

support for the oscillating tube(s)

3.1.8

housing

environmental protection of the flow sensor and/or transmitter

3.1.9

secondary containment

housing designed to provide protection to the environment in the event of tube failure

3.1.10

calibrating factor

numerical factor unique to each sensor derived during sensor calibration

Note 1 to entry: The calibrating factor is programmed into the transmitter to enable flowmeter operation.

3.1.11

zero offset

indicated flow when there are zero flow conditions present at the meter

Note 1 to entry: This could be due to mechanical or electrical noise superimposed on the sensor output but equally could be due to installation effects such as torsional loading caused by improper torquing of the flange bolts or temperature extremes creating deflection of the pipeline.

3.1.12

zero stability

variation of the flowmeter output at zero flow after the zero adjustment procedure has been completed, expressed by the manufacturer as an absolute value in mass per unit time

3.1.13

flashing

phenomenon, which occurs when the line pressure drops to, or below, the vapour pressure of the liquid

Note 1 to entry: This is often due to pressure drops caused by an increase in liquid velocity.

Note 2 to entry: Flashing is not applicable to gases.

3.1.14

cavitation

phenomenon related to and following flashing of liquids if the pressure recovers causing the vapour bubbles to collapse (implode)

3.1.15

flow rate

quotient of the quantity of fluid passing through the cross-section of the conduit and the time taken for this quantity to pass through this section

3.1.16

mass flow rate

flow rate in which the quantity of fluid is expressed as mass

3.1.17

volume flow rate

flow rate in which the quantity of fluid is expressed as volume

3.2 Definitions from VIM, ISO/IEC Guide 99 (JCGM:2012)

3.2.1

repeatability (condition of measurement)

condition of measurement, out of a set of conditions that includes the same measurement procedure, same operators, same measuring system, same operating conditions, and same location, and replicate measurements on the same or similar objects over a short period of time

Note 1 to entry: A condition of measurement is a repeatability condition only with respect to a specified set of repeatability conditions environmental protection of the flow sensor and/or transmitter.

3.2.2

measurement uncertainty

non-negative parameter characterizing the dispersion of the quantity values being attributed to a measurand, based on the information used

Note 1 to entry: Measurement uncertainty includes components arising from systematic effects, such as components associated with corrections and the assigned quantity values of measurement standards, as well as the definitional uncertainty. Sometimes estimated systematic effects are not corrected for but, instead, associated measurement uncertainty components are incorporated.

Note 2 to entry: Measurement uncertainty comprises, in general, many components. Some of these can be evaluated by Type A evaluation of measurement uncertainty from the statistical distribution of the quantity values from series of measurements and can be characterized by standard deviations. The other components, which can be evaluated by Type B evaluation of measurement uncertainty, can also be characterized by standard deviations, evaluated from probability density functions based on experience or other information.

3.2.3

error

measured quantity value minus a reference quantity value

Note 1 to entry: The concept of “measurement error” can be used both a) when there is a single reference quantity value to refer to, which occurs if a calibration is made by means of a measurement standard with a measured quantity value having a negligible measurement uncertainty or if a conventional quantity value is given, in which case the measurement error is known, and b) if a measurand is supposed to be represented by a unique true quantity value or a set of true quantity values of negligible range, in which case the measurement error is not known.

3.2.4

calibration

operation that, under specified conditions, in a first step, establishes a relation between the quantity values with measurement uncertainties provided by measurement standards and corresponding indications with associated measurement uncertainties and, in a second step, uses this information to establish a relation for obtaining a measurement result from an indication

Note 1 to entry: A calibration can be expressed by a statement, calibration function, calibration diagram, calibration curve, or calibration table. In some cases, it can consist of an additive or multiplicative correction of the indication with associated measurement uncertainty.

Note 2 to entry: Calibration should not be confused with adjustment of a measuring system, often mistakenly called “self-calibration”, nor with verification calibration.

3.3 Symbols

Table 1 — Symbols used in this International Standard

Symbol	Description	Dimensions	SI Units
A_{id}	oscillating tube internal cross-sectional area	L^2	m^2
a_r	radial acceleration	LT^{-2}	m/s^2
a_t	transverse acceleration	LT^{-2}	m/s^2
V	velocity	LT^{-1}	m/s
δm_f	delta mass of a flowing particle	M	kg
δm_{tb}	mass of tube element	M	kg
δF_C	delta Coriolis force	MLT^{-2}	$m \cdot kg/s^2$
q_m	mass flow rate	MT^{-1}	kg/s
ρ	density	ML^{-3}	kg/m^3
ρ_f	density of the fluid	ML^{-3}	kg/m^3
ρ_{ref}	density of reference liquid	ML^{-3}	kg/m^3
tb	tube	dim-less	—
$F_{C,Inlet}$	resultant Coriolis force in the inlet	MLT^{-2}	$m \cdot kg/s^2$
$F_{C,Outlet}$	resultant Coriolis force in the outlet	MLT^{-2}	$m \cdot kg/s^2$
F_C	Coriolis force	MLT^{-2}	$m \cdot kg/s^2$
sin_D	sinusoidal function (displacement, velocity, or acceleration)	$L, LT^{-1}, \text{ or } LT^{-2}$	$m, m/s, \text{ or } m/s^2$
sin_A	sinusoidal function (displacement, velocity, or acceleration)	$L, LT^{-1}, \text{ or } LT^{-2}$	$m, m/s, \text{ or } m/s^2$
sin_B	sinusoidal function (displacement, velocity, or acceleration)	$L, LT^{-1}, \text{ or } LT^{-2}$	$m, m/s, \text{ or } m/s^2$
t_d	time delay	T	s
K_R	a constant, primary flow calibration factor at reference conditions	MT^{-1}	$kg/s/s$
ω	angular velocity	T^{-1}	rad/s
r	length	L	m
δx	delta length	L	m
f_{rf}	resonant frequency	T	Hz
C	mechanical stiffness	MT^{-2}	kg/s^2
m	mass	M	kg
M	total mass – over a period of time	MT^{-1}	kg/s
m_{tb}	mass of oscillating tube(s)	M	kg
m_f	mass of fluid within the oscillating tube(s)	M	kg
V_f	volume of fluid within the oscillating tube(s)	L^3	m^3
V	total volume – over a period of time	L^3T^{-1}	m^3/s
K_1, K_2	density calibration factors	dim-less	—
T_{rf}	is the period of the oscillating tube	T	s
N_c	number of cycles	dim-less	—
t_w	is the time window (gate)	T	s
ρ_{ref}	the density of water at reference conditions	ML^{-3}	kg/m^3

Symbol	Description	Dimensions	SI Units
U_v	expected uncertainty of the flow measurement volume	percent of reading	—
U_m	expected uncertainty of the mass flow measurement	percent of reading	—
U_ρ	expected uncertainty of the density measurement	percent of reading	—
w_A	mass fraction of component A	dim-less	—
w_B	mass fraction of component B	dim-less	—
φ_A	volume fraction of component A	dim-less	—
φ_B	volume fraction of component B	dim-less	—
ρ_A	density of component A	ML ⁻³	kg/m ³
ρ_B	density of component B	ML ⁻³	kg/m ³
ρ_{ms}	density of measured mixture density	ML ⁻³	kg/m ³
q_{mA}	mass flow rate of component A	MT ⁻¹	kg/s
q_{mB}	mass flow rate of component B	MT ⁻¹	kg/s
q_{mT}	total mass flow rate of the mixture	MT ⁻¹	kg/s
q_{vA}	volume flow rate of component A	L ³ T ⁻¹	m ³ /s
q_{vB}	volume flow rate of component B	L ³ T ⁻¹	m ³ /s
q_{vT}	total volume flow rate of the mixture	L ³ T ⁻¹	m ³ /s

3.4 Abbreviations

Table 2 — Abbreviations used in this International Standard

Abbreviations	Descriptions
cP	centipoise (dynamic viscosity) 1 cP = 1 mPa·s
cSt	CentiStokes (kinematic viscosity) 1 cSt = 1 mm ² /s
cP/SG	viscosity used in petroleum industry
DN	European piping size (diameter nominal, millimetres)
SG	specific gravity
SIP	steaming-in-place
CIP	cleaning-in-place

4 Coriolis flowmeter selection criteria

4.1 General

The Coriolis flowmeter should be selected to measure the user's parameters within their required ranges and uncertainty. Consideration should be given to the following points when selecting a Coriolis flowmeter.

Coriolis flowmeters are not generic devices. The potential user should review the manufacturer's data sheet(s) carefully.

4.2 Physical installation

4.2.1 General

The manufacturer should describe the recommended installation arrangement and state any restrictions of use.

The installation arrangement design enables measurement to meet the user's requirements. Installation for liquid and gas measurement can be different. Some applications might need strainers or filters, and other applications might need air and/or vapour eliminators.

Coriolis flowmeters are regularly placed in the mainstream of the flow but can also be placed in a by-pass arrangement for density measurements.

4.2.2 Installation criteria

Consider the following, noting that there might be differences for liquid and gas measurement applications:

- a) the space required for the Coriolis flowmeter installation, including provision for external prover or master-meter connections, should *in situ* calibration be required;
- b) the class and type of pipe connections and materials, as well as the dimensions of the equipment to be used;
- c) the hazardous area classification;
- d) the environmental effects on the sensor, for instance, temperature, humidity, corrosive atmospheres, mechanical shock, vibration, and electromagnetic field;
- e) the mounting and support requirements.

4.2.3 Full-pipe requirement for liquids

The primary device should be mounted such that the oscillating tube(s) fill completely with the liquid being metered; this prevents the measuring performance of the instrument from being impaired. The manufacturer should state the means, if any, required to purge or drain gases or liquids from the instrument.

4.2.4 Orientation

Plugging, coating, trapped gas, trapped liquid, or settlement of solids can affect the flowmeter's performance. The orientation of the sensor depends on the intended application of the flowmeter and the geometry of the oscillating tube(s). The orientation of the Coriolis flowmeter should be recommended by the manufacturer.

4.2.5 Flow conditions and straight length requirements

The performance of a Coriolis flowmeter in single phase flow is usually not affected by swirling fluid or non-uniform velocity profiles induced by upstream or downstream-piping configurations.

4.2.6 Valves

Valves upstream and downstream to a Coriolis flowmeter, installed for the purpose of isolation and zero adjustment, can be of any type, but should provide tight shutoff. Control valves in series with a Coriolis flowmeter should be installed downstream to maintain the pressure required to ensure the product remains single phase and no flashing or cavitation can occur.

4.2.7 Cleaning

For certain applications (for instance hygienic services), the Coriolis flowmeter might require *in situ* cleaning which can be accomplished by

- a) mechanical means (using a pig or ultrasonic device),
- b) self-draining,

- c) hydrodynamic means,
- d) sterilization (steaming-in-place, SIP), and
- e) chemical or biological (cleaning-in-place, CIP).

Care should be taken to avoid cross-contamination after cleaning fluids have been used.

Chemical compatibility should be established between the sensor wetted-materials, process fluid, and cleaning fluid.

4.2.8 Hydraulic and mechanical vibrations

The manufacturer should specify the operating frequency range of the instrument to enable assessment of possible influences of process or other external mechanically imposed frequencies. It is possible that the performance of the flowmeter can be influenced by frequencies other than the operating frequencies. These effects can largely be addressed by appropriate mounting or clamping of the instrument.

In environments with high mechanical vibrations or flow pulsations, consideration should be given to the use of pulsation damping devices (see [4.3.7](#)) and/or vibration isolators and/or flexible connections.

4.2.9 Pipe stress and torsion

The flow sensor is subjected to axial, bending, and torsional forces during operation. Changes in these forces, resulting from variations in process temperature and/or pressure, can affect the Coriolis mass flow measurement. Care should be taken to ensure that no forces are exerted on the flowmeter from the clamping arrangements.

Measures should also be taken to prevent alignment stresses from being exerted on the Coriolis flowmeter by connecting pipes.

Under no circumstances should the Coriolis flowmeter be used to align the pipe work.

4.2.10 Crosstalk between sensors

If two or more Coriolis flowmeters are to be mounted close together, interference through mechanical coupling might occur. This is often referred to as crosstalk. The manufacturer should be consulted for methods of avoiding crosstalk.

This should be recognized in the mechanical design of an installation to avoid interference or “crosstalk”. Testing should be carried out after installation as flowmeter errors introduced can be significant but not obvious in normal operation. If observed, the manufacturer should be consulted.

4.3 Effects due to process conditions and fluid properties

4.3.1 General

Variations in fluid properties, such as density, viscosity, and process conditions, such as pressure and temperature, can influence the flowmeter’s performance. These effects have influences which differ depending on which parameter is of interest.

4.3.2 Application and fluid properties

In order to identify the optimum flowmeter for a given application, it is important to establish the range of conditions to which the Coriolis flowmeter will be subjected. These conditions should include the following:

- a) flow rates;
- b) the range of densities;

- c) the range of temperatures;
- d) the range of pressures;
- e) the pressure on the liquid adequate to prevent cavitation and flashing;
- f) the permissible pressure loss;
- g) the range of viscosities;
- h) the properties of the metered fluids, including vapour pressure, two-phase flow, and corrosiveness;
- i) unidirectional or bi-directional;
- j) continuous, intermittent, or fluctuating;
- k) corrosive additives (the effects of corrosive additives or contaminants on the flowmeters and the quantity and size of foreign matter, including abrasive particles that can be carried in the liquid stream).

4.3.3 Multiphase flow

Liquid mixtures, homogeneous mixtures of solids in liquids, or homogeneous mixtures of liquids with entrained gas can be measured satisfactorily. Applications with two or more phases involving non-homogeneous mixtures can cause additional measurement errors and in some cases, can stop operation of the Coriolis flowmeter. Because of the random appearance of these effects, as well as the multitude of application specific parameters influencing the measurement (e.g. flow profile, fluid velocity, density, etc.), the impact on the measurement uncertainty is not fully predictable. Therefore, means to reduce the influence by prevention (e.g. by installing adequate tank-level control systems or by installing an adequate gas separator device) can be advisable. The installation of these devices, such as tank level controls and gas separators, is beyond the scope of this International Standard.

Gases dissolved in the liquid can also lead to flashing, due to pressure loss in the upstream piping or in the Coriolis flowmeter. Gas bubbles can lead to the creation of larger voids, which might disrupt the measurement. Increasing pressure (e.g. by installing the sensor on the high-pressure side of a pressure limitation device or control valve) helps keep the entrained gas in solution. If the gas is kept well mixed and distributed to avoid imbalance of gas content between measurement tubes or inlet and outlet section of the tube(s), the operability is maintained to higher gas volume fractions and lower measurement uncertainty.

In the case of batch applications where the pipelines are empty at the start, a large gas void can be forced through the Coriolis flowmeter by the liquid at the beginning of the batch process. Due to the undefined error behaviour of the Coriolis flowmeter, the time required to fill the Coriolis flowmeter should be kept as short as possible.

NOTE To discriminate the different components of the mixture, when more than two components are present (e.g. water, gas, and oil), additional measurements are required (e.g. pressure, relative permittivity, percentage water, or velocity). Typically, this is a task of a multiphase metering system.

4.3.4 Influence of process fluid

Erosion, corrosion, and deposition of material on the inside of the oscillating tube(s) (sometimes referred to as coating) can initially cause measurement errors in flow and density, and in the longer term, sensor failure.

4.3.5 Temperature effects

A change in oscillating tube(s) temperature affects the properties of the oscillating tube(s), and thus influences the measurement of the fluid process by the Coriolis flowmeter. A means of compensation for this temperature effect is usually incorporated in the transmitter.

Users are advised to discuss temperature effects with the flowmeter manufacturer.

4.3.6 Pressure effects

Static pressure changes can affect the measurement of the fluid process by the Coriolis flowmeter; the extent of the effect on measurement shall be specified by the manufacturer.

4.3.7 Pulsating flow effects

Coriolis flowmeters are generally able to perform under pulsating flow conditions except when pulsation is relatively severe, which is often the case when reciprocating product pumps are in close proximity to the metering system. When this situation occurs, steps should be taken to reduce pulsations to levels that do not affect performance. This often requires passing through intermediate equipment, improving pulsation damping equipment, changing pump type, etc. (see [4.2.8](#)). The manufacturers' recommendations should be observed regarding the application and the possible use of pulsation damping devices.

4.3.8 Viscosity effects

Higher viscosity fluids might draw energy from the Coriolis flowmeter excitation system, particularly at the start of flow. This phenomenon can cause the sensor tube(s) to momentarily stall during start up.

A calibration verification of the Coriolis flowmeter with higher viscosity fluids can be a consideration if high performance is required with greatly varying viscosities.

4.3.9 Flashing and/or cavitation

The relatively high liquid velocities and quick change in these velocities, which often occur in Coriolis flowmeters, cause local dynamic pressure drops inside the flowmeter, which can result in flashing and/or cavitation.

Both flashing and cavitation in Coriolis flowmeters (and immediately upstream and/or downstream of them) should be avoided at all times. Flashing and cavitation cause measurement errors and can damage the sensor.

4.4 Pressure loss

A loss in pressure occurs as the fluid flows through the sensor. The magnitude of this loss is a function of the size and geometry of the oscillating tube(s), the mass flow rate, and the dynamic viscosity of the process fluid.

Manufacturers shall provide a process (a sizing program or a diagram) for users to determine the pressure losses across the flowmeter.

4.5 Safety

4.5.1 General

The flowmeter should not be used at conditions, which are outside the flowmeter's specification. Flowmeters also should conform to any necessary hazardous area classifications. The following additional safety considerations should be made.

4.5.2 Hydrostatic pressure test

The wetted parts of the fully assembled flowmeter sensor should be hydrostatically tested in accordance with the appropriate standard.

4.5.3 Mechanical stress

The flowmeter should be designed to withstand all loads originating from the oscillating tube(s) system, temperature, pressure, and pipe vibration. The user should respect the limitations of the sensor at all times.

4.5.4 Erosion

Fluids containing solid particles or cavitation can cause erosion of the oscillating tube(s) during flow. The effect of erosion is dependent on flowmeter size and geometry, particle size, abrasives, and velocity. Erosion should be assessed for each type of use of the flowmeter.

4.5.5 Corrosion

Corrosion, including galvanic corrosion, of the wetted materials can adversely affect the operating lifetime of the flowmeter sensor, pipe, and flanges. The construction material of the flowmeter sensor should be selected to be compatible with process fluids and cleaning fluids. Special attention should be given to corrosion and galvanic effects in no-flow or empty-pipe conditions. Corrosion also affects the flowmeter's performance. All process-wetted materials should be specified.

4.5.6 Housing design

The housing should be designed primarily to protect the flow sensor from deleterious effects from its surrounding environment (dirt, condensation, and mechanical interference) which might interfere with operation. If the vibrating tube(s) of the Coriolis flowmeter were to fail, the housing containing the tube(s) would be exposed to the process fluid and conditions which could possibly cause housing failure.

It is important to take into consideration the following possibilities:

- a) the pressure within the housing might exceed the design limits;
- b) the fluid might be toxic, corrosive, or volatile, and might leak from the housing.

In order to avoid such problems, certain housing designs provide the following:

- a) secondary pressure containment;
- b) burst discs or pressure-relief valves, fluid drains, or vents.

For guidelines on specifying secondary pressure containment, see [Annex B](#).

4.5.7 Cleaning

For general guidelines see [4.2.7](#).

Care should be taken to ensure that cleaning conditions (fluids, temperatures, flow rates, etc.) have been selected to be compatible with the materials of the Coriolis flowmeter.

4.6 Transmitter (secondary device)

Coriolis flowmeters are multivariable instruments providing a range of measurement data from a single point in the process. In selecting the most appropriate transmitter, consideration should be given to the following:

- a) the electrical, electronic, climatic, and safety compatibility;
- b) the mounting, i.e. integrally or remotely mounted;
- c) the required number and type of outputs;
- d) the ease and security of programming;

- e) the outputs demonstrating adequate stability and reasonable response times, and in the case of an analogue output including the minimum and maximum span adjustments;
- f) the output(s) indicating system errors;
- g) the required input options, for instance remote zero adjustment, totalizer resetting, and alarm acknowledgement;
- h) the type of digital communication;
- i) secondary instrument inputs, such as process pressure, temperature, and density;
- j) level of measurement uncertainty.

4.7 Diagnostics

Coriolis flowmeters provide a variety of electronic signals going from the transmitter to the sensor, e.g. the electric current, used to provide the oscillation of the measurement tube(s), as well as going back from the sensor to the transmitter, e.g. the frequency modulated signal from the motion sensing devices.

While the purpose of those signals is primarily to ensure the operation of the measurement principle, they also carry additional information that can be used for diagnostic functionality — either by comparison with reference values or by software algorithms. This functionality can be integrated into the transmitter or provided as data for further processing by the control system. Diagnostic functions can be used to indicate more detailed information on process or system conditions. The user should consult with the manufacturer to understand the availability diagnostics.

5 Inspection and compliance

Coriolis flowmeters are an integral part of the piping (in-line instrumentation), it is essential that the instrument be subjected to testing procedures similar to those applied to other in-line equipment.

All calibrations and testing shall be completed by an ISO 17025 accredited laboratory or alternative with comparable quality systems and demonstrably traceable measurements to national and International Standards.

In addition to the instrument calibration and/or performance checks, the following optional tests can be performed to satisfy the mechanical requirements:

- a) dimensional check;
- b) additional hydrostatic test, in accordance with a traceable procedure, as specified by the user;
- c) radiographic and/or ultrasonic examination of the primary device to detect internal defects (i.e. inclusions) and verify weld integrity.

Results of the above tests should be presented in a certified report, when requested.

In addition to the above reports, the following certificates should be available at final inspection:

- 1) material certificates, for all pressure-containing parts;
- 2) certificate of conformance (electrical area classifications);
- 3) certificate of compliance;
- 4) calibration certificate and test results.

6 Mass flow measurement

6.1 Apparatus

6.1.1 Principle of operation

Coriolis flowmeters operate on the principle that inertia forces are generated whenever a particle in a rotating body moves relative to the body in a direction towards or away from the centre of rotation. This inertial force is called the Coriolis force and its principle is shown in [Figure 1](#).

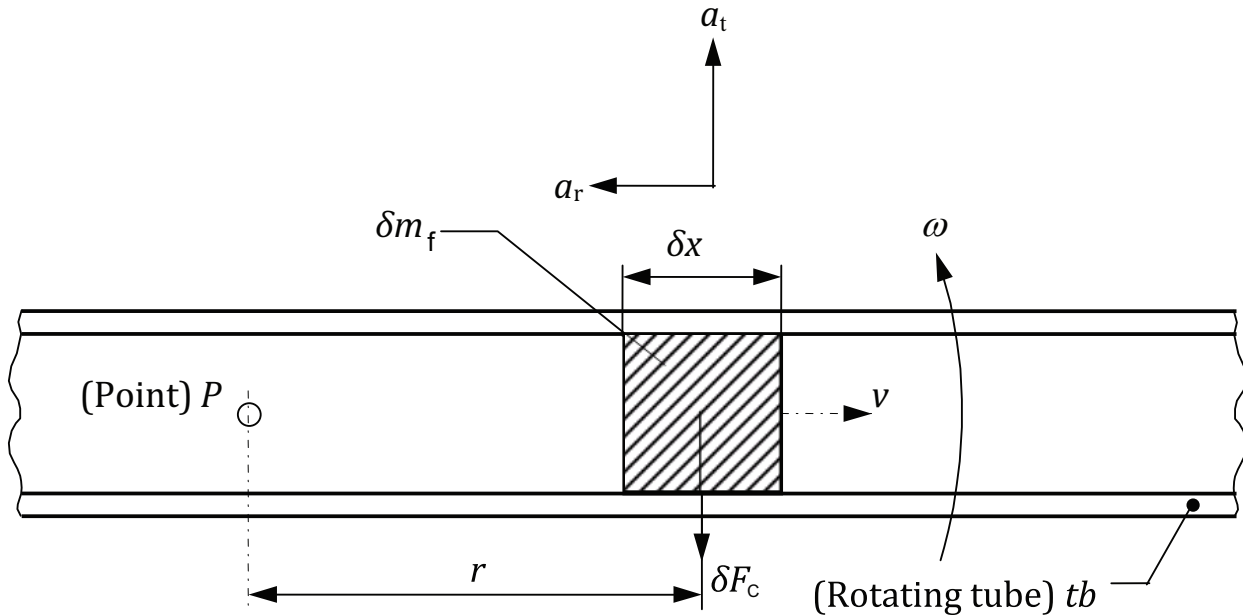

Figure 1 — Principle of the Coriolis force in a rotating tube

A flowing particle, of mass δm_f , slides with constant velocity, v , in a tube, tb , which is rotating with angular velocity, ω , at a certain distance, r , from a fixed point, P . The particle undergoes an acceleration that can be divided into two components

- a radial acceleration (centripetal), a_r , equal to $r\omega^2$ and directed towards P , and
- a transverse acceleration (Coriolis), a_t , equal to $2v\omega$ at right angles to a_r and in the direction shown in [Figure 1](#).

To impart the Coriolis acceleration a_t to the particle, a force of magnitude $2\omega v\delta m_f$ is required in the direction of a_t . The rotating tube exerts this force on the particle. The particle reacts to this force with an equal force called the Coriolis force, δF_C which is defined as follows:

$$\delta F_C = 2\omega v\delta m_f \quad (1)$$

When a flowing particle of density, ρ , flows at constant velocity, v , along a tube rotating as shown in [Figure 1](#), any length, δx , of the rotating tube experiences a transverse Coriolis force of magnitude:

$$\delta F_C = 2\omega v\rho A_{id}\delta x \quad (2)$$

where A_{id} is the cross-sectional area of the rotating tube interior.

Since the mass flow rate, q_m , can be expressed as:

$$q_m = v\rho A_{id} \quad (3)$$

The transverse Coriolis force, δF_C , can therefore be expressed as follows:

$$\delta F_C = 2\omega q_m \delta x \quad (4)$$

In commercial Coriolis flowmeters, direct measurement of the Coriolis force in rotating tubes is not used. Instead, measurement is commonly done through vibrating flow tubes since vibration contains a certain form of rotational motion. The typical operation based on the vibratory principle is shown schematically in [Figure 2](#).

In [Figure 2 a\)](#), the flow tube is supported at the inlet and outlet positions and its shape can be either bent or straight. With a vibration driving mechanism normally arranged in the middle, the flow tube is excited to a continuous sinusoidal motion. For example, in the driving position, the motions of the fluid particle, δm_f , and the tube element, δm_{tb} , are coupled together, and it can be represented by a sinusoidal function, \sin_D .

Ideally, when there is no flow, the sinusoidal motions of the inlet and outlet portions, \sin_A and \sin_B , are in phase as shown in [Figure 2 b\)](#).

When flow occurs, Coriolis forces are generated in the inlet and outlet portions because of the fluid velocity, v , and the rotational components, ω , of the inlet and outlet fluid particles. However, the resultant Coriolis forces in the inlet and outlet portions, $F_{C,Inlet}$ and $F_{C,Outlet}$, are opposite to each other because of the opposite rotational components of the inlet and outlet fluid particles as illustrated in [Figure 2 a\)](#). Therefore, the sinusoidal motions of the inlet and outlet portions, \sin_A and \sin_B , are no longer in phase as shown in [Figure 2 c\)](#). The mass flow rate is in direct proportion to the time delay, t_d , between these two sinusoidal signals as given by Formula (5):

$$q_m = K_R \cdot t_d \quad (5)$$

where

K_R is a constant and is the primary flow calibration factor at the reference condition.

It should be noted that in [Figure 2 c\)](#), time delay is shown at the peaks of sinusoidal signals, and this is simply for the purpose of illustration. In theory, time delay can be measured anywhere along two sinusoidal signals. Therefore, different manufacturers can have different techniques to measure this time delay. Ideally, when there is no flow, the sinusoidal motions of the inlet and outlet portions, \sin_A and \sin_B , are in phase as shown in [Figure 2 b\)](#). It should be noted that the sinusoidal motions, which can be in the form of displacement, velocity, acceleration, or deformation, can be sensed by various means and commercial Coriolis flowmeters which typically use magnet/coil sensors to sense velocity.

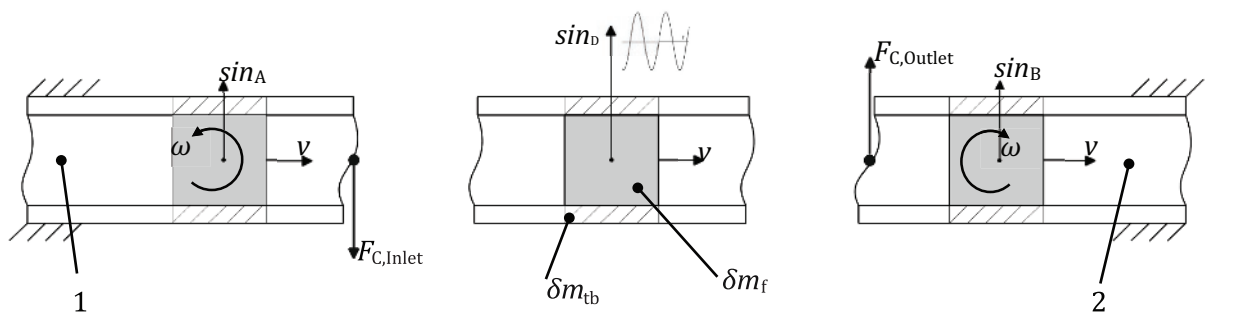

a) Motion in the completed tube system

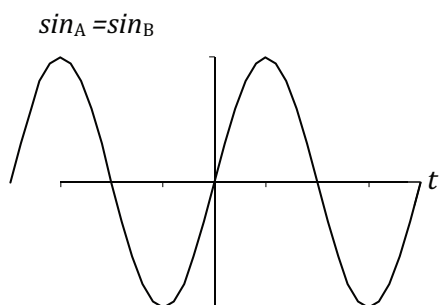

b) No flow

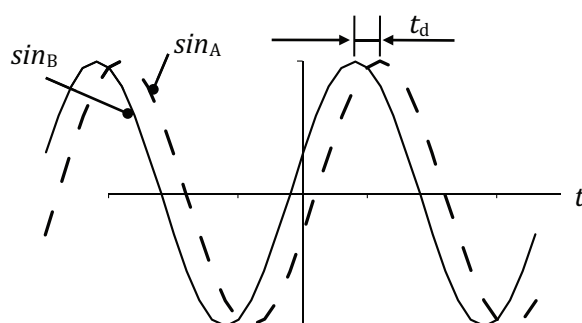

c) With flow

Key

- 1 tube inlet
- 2 tube outlet

Figure 2 — Principle of operation of Coriolis flowmeters for mass flow measurement

6.1.2 Coriolis sensor

A Coriolis flowmeter is an electromechanical system which consists of a flow sensor and a transmitter. The Coriolis flowmeter sensor is the primary mechanical part while the transmitter provides control and signal processing.

One or more flow tubes are included in the internal measuring assembly, which can be either bent or straight. In most flowmeters, the flow tube is fixed between inlet and outlet points and oscillated at a position midway between these two points. The oscillation is normally excited electromagnetically using coils and magnets. Motion sensing devices are also included in the flow sensor to detect the motions on both the inlet and outlet portions.

The supporting structure typically includes sensor housing to provide protection or secondary containment. It also includes process connection to be connected to users' pipeline.

The sensor is characterized by flow calibration factors which are derived during manufacture and calibration. These values are unique for each sensor and are normally recorded on a calibration certificate and/or a data plate secured to the sensor housing.

6.1.3 Coriolis transmitter

A Coriolis flowmeter requires a transmitter to provide the drive energy and to process the subsequent signals. It is necessary to match the transmitter to the sensor by entering the calibration factors from the sensor data plate or the calibration certificate.

The mass flow rate is usually integrated over time in the transmitter to give the total mass.

The transmitter might contain application software which can be used to evaluate additional parameters but they require further configuration. In the case of the measurement of density or volume, output requirements necessitate the entry of other coefficients into the software. All outputs are usually scaled separately.

6.2 Mass flow measurement

It is important to note that the result of a measurement is an estimate of the physical quantity being measured. When reporting the measurement result, it is therefore essential that a quantitative indication of the quality of the result is included, allowing those who use the results to evaluate the extent of its validity. Without such an indication, measurement results should not be compared neither among themselves nor with reference values of a specification or standard.

Measurement uncertainty is a parameter that characterizes the dispersion of measured values associated with the result of a measurement. It is normally expressed as a percentage of the reading with a confidence interval, usually assumed to be 95 %. The measurement uncertainty needs to be estimated by including all reasonable contributing factors under the specified conditions, which include not only those contributions arising from the meter itself but also the calibration facility, process, and installation conditions.

Coriolis flowmeter manufacturers frequently specify mass flow measurement performance as a percentage of the reading. The manufacturer's published performance specification for mass flow includes the combined effects of accuracy and zero stability. The manufacturer's accuracy specification includes repeatability, hysteresis, and linearity but can also include other items that can be different for each manufacturer. Manufacturers' published performance specifications usually contain a clause like, at reference conditions. Reference conditions are generally not the same for Coriolis manufacturers.

In order to determine the Coriolis flowmeter's predicted performance at a flow rate, two approaches are normally used by Coriolis manufacturers. In the first approach, zero stability is calculated as a percentage of the reading at the specified flow rate and added on to a base accuracy value to define the performance specification as shown in the following graph as [Figure 3](#).

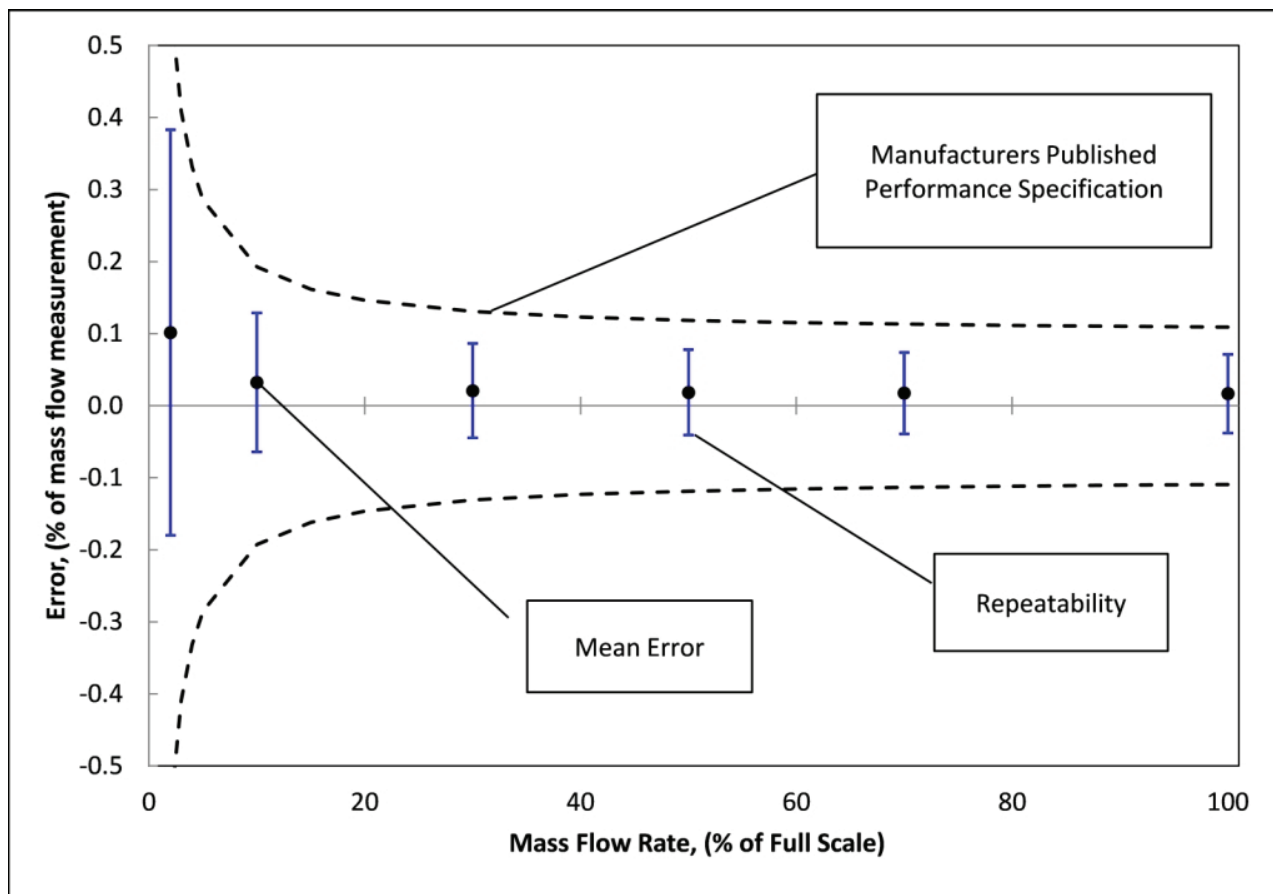

Figure 3 — Typical graph of Coriolis' manufacturers published performance specifications, first approach

In a second approach to determine a Coriolis flowmeter's predicted performance, a certain flow rate is used to determine either zero stability or a base accuracy value will be used. Below that certain flow rate, zero stability is calculated as a percentage of the reading at the specified flow rate to determine the performance specification. Above that certain flow rate, the base accuracy value is used as a constant to determine the performance specification. This second approach is shown in [Figure 4](#) below.

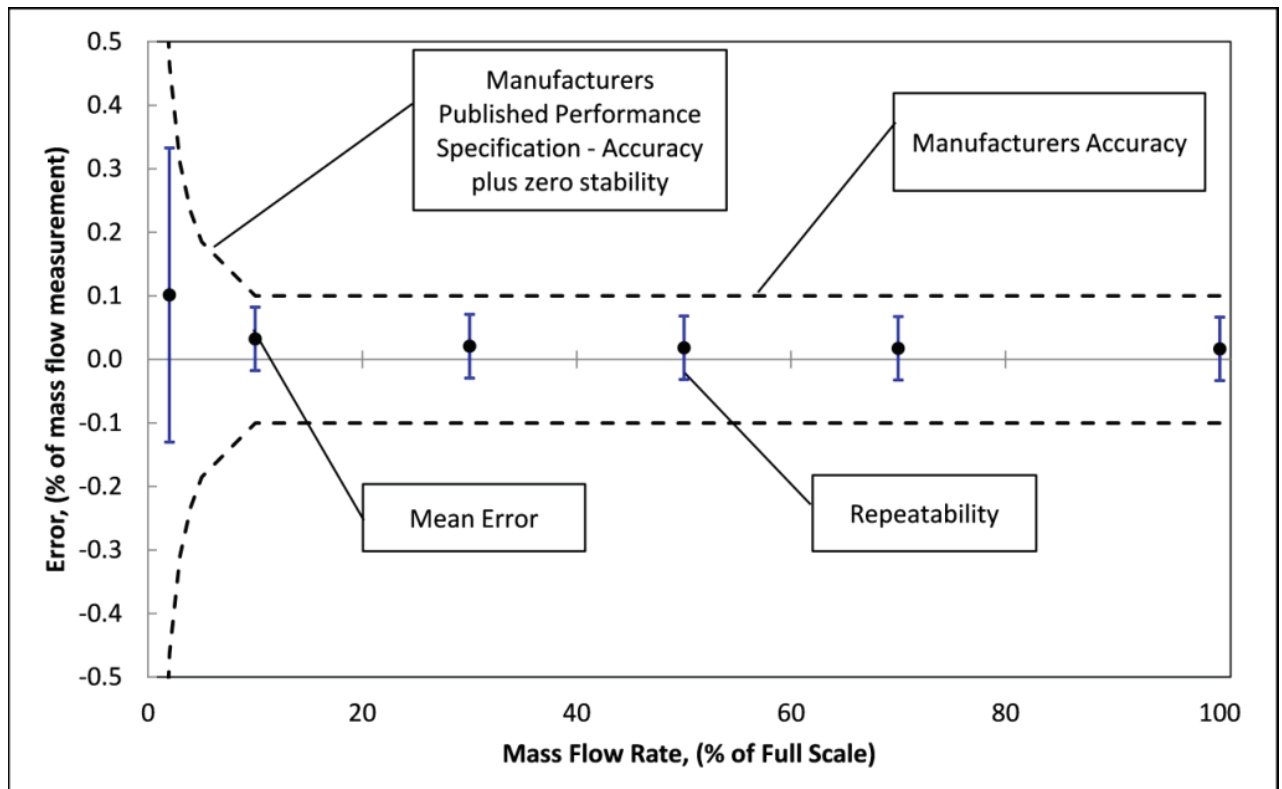

Figure 4 — Typical graph of Coriolis manufacturer's published performance specifications, second approach

Since manufacturers' published performance specifications are normally defined for reference conditions using a calibration facility, estimation of measurement uncertainty needs to consider and add other reasonable contributing factors. These additional uncertainties are described in more detail in 4.3 and can include the following:

- a) the calibration facility's uncertainty, which is usually available on a calibration certificate;
- b) possible errors due to process conditions deviating away from the specific reference conditions, such as process temperature and pressure;
- c) possible errors due to installation conditions, such as environmental temperature changes.

6.3 Factors affecting mass flow measurement

6.3.1 Density and viscosity

Density and viscosity may have a minor effect on measurements of mass flow. Consequently, compensation is not normally necessary. However, for some designs and sizes of meters, density and/or viscosity changes can induce an offset in the flowmeter output at zero flow and/or a change in the flowmeter calibration factor. The offset can be eliminated by performing a zero adjustment (see 6.4) at operating conditions. See 4.3.8 for viscosity effects.

6.3.2 Multiphase flow

Liquid mixtures, homogeneous mixtures of solids in liquids, and homogeneous mixtures of liquids with a low ratio of gas can be measured satisfactorily in many cases. Multiphase fluid flow should be avoided because the measurement of multiphase fluids results in increased uncertainty. Multiphase applications involving non-homogeneous mixtures can cause additional measurement errors.

Care should be taken to ensure that gas bubbles or condensate droplets are not trapped in the flowmeter (see 4.2.4). Special attention should be given under these circumstances to the zero-adjustment procedure (see 6.4).

6.3.3 Temperature

Temperature changes affect the flow calibration factor due to temperature related material properties and compensation is necessary. Compensation for this effect is usually performed by the transmitter using the measured tube temperature.

However, large differences in temperature between the oscillating tube(s) and the ambient temperature can cause errors in the temperature compensation. The use of insulation materials can minimize these effects. Temperature variations can also induce an offset in the flowmeter output at zero flow.

6.3.4 Pressure

Pressure may have a minor effect on measurements of mass flow and compensation is not normally necessary. However, for some designs and sizes of flowmeters, pressure changes can affect the flow calibration factor and, in this case, compensation is necessary. Pressure changes can also induce an offset in the flowmeter output at zero flow. This effect can be eliminated by performing a zero adjustment (see 6.4) at the process pressure.

6.3.5 Installation

Stresses exerted on the sensor from surrounding pipe work can introduce an offset in the flowmeter output at zero flow, which affects the uncertainty over the entire flow range for some designs and sizes of flowmeters. This offset should be checked after the initial installation or after any subsequent change in the installation. Another zero adjustment (see 6.4) should be performed if the offset is unacceptable.

6.4 Zero adjustment

Zero offset is the result of mechanical noise that is indistinguishable from the mass flow induced Coriolis effects. It can be determined and compensated for when flow is at zero. Coriolis flowmeters are typically balanced during manufacture to minimize these effects. However, even with proper balancing and proper installation, some residual offset due to external mechanical noise might exist. Coriolis meters manufacturers provide a procedure for determining and compensating zero offset.

Once the flowmeter installation is complete, a zero adjustment might be necessary for some flowmeter designs to overcome the effects described in 6.3. Refer to the vendor's manual. To check or adjust the zero flow, the flowmeter should be full and all flow stopped by closing upstream and downstream valves. It is recommended that the meter zero is first checked, and adjusted if the offset is larger than the manufacturer's specification or unacceptable to the user. Zero adjustment should be made at process conditions of temperature, pressure, and density. It is essential that the fluid remain stable and that there are no bubbles or heavy sediment and no movement.

The level of the zero adjustment can be checked by observing the flowmeter output at zero flow. However, before viewing the output, it is essential that the mass low flow cut-off setting in the transmitter be set to zero or alternatively, an output unaffected by the mass low flow cut-off setting be used. If appropriate, the bi-directional function might need to be activated. It is advisable to check the zero of the flowmeter periodically.

NOTE Mass flow rate low flow cut-off is a transmitter setting which sets the flowmeter mass flow output to zero if the mass flow rate falls below a pre-set value.

6.5 Calibration of mass flow measurement

Every Coriolis flowmeter should be calibrated against a standard traceable to a national or International Standard. It is preferred that calibration laboratories be accredited to ISO/IEC 17025. Calibration

certificates for the flowmeter should be provided. The calibration factors determined by this procedure should be indelibly marked on the sensor data plate.

The calibration of a Coriolis flowmeter consists of comparing the output of the flowmeter against a traceable standard which has a better uncertainty, preferably at least three times better, than the flowmeter under test.

As the Coriolis flowmeter is a mass flow device, it is preferable to perform the calibration against a mass or gravimetric reference. Calibration against a volume standard combined with density determination can be used in situations where mass or gravimetric methods are not available or not possible, especially when making field calibrations. The errors introduced by this method have to be carefully assessed. If a Coriolis flowmeter master meter is used, care should be taken to avoid cross-talk (see [4.2.10](#)).

Factory calibration is normally done using water. Prior to the start of the calibration, the zero of the flowmeter should be checked (see [6.4](#)). The Coriolis flowmeter might need to have a zero adjustment in the calibration test rig and again in the final installation. Detailed calibration advice, calibration intervals, suggested procedures, calibration levels, and an example of a calibration curve are given in [Annex A](#).

7 Density measurement

7.1 General

Coriolis flowmeters can provide in-line density measurement at metering conditions. This section outlines density measurements and density calibration using Coriolis flowmeters. Density-based inferred measurements such as standard density and concentration are dealt with in [Annex C](#).

CAUTION — At the time of writing, the gas density measurement capability of Coriolis flowmeters is generally limited. Therefore, using the gas density measurement to convert mass flow of gas to actual volumetric flow of gas is also limited. The manufacturer should be consulted regarding the uncertainty and validity of an actual volume measurement provided under gas flow conditions.

7.2 Principle of operation

Coriolis flowmeters are typically operated at their resonant frequency. For a resonant system there is a relationship between this frequency and the oscillating mass and stiffness. The resonant frequency (f_{rf}) of a Coriolis flowmeter and related formulae are written as:

$$f_{rf} = (1/2\pi)(C/m)^{1/2} \quad (6)$$

with

$$m = m_{tb} + m_f \quad (7)$$

and

$$m_f = (\rho_f) \cdot (V_f) \quad (8)$$

where

f_{rf} is the resonant (natural) frequency;

C is the mechanical stiffness or the spring constant of the oscillating tube arrangement;

m is the total mass;

m_{tb} is the mass of oscillating tube(s);

m_f is the mass of fluid within the oscillating tube(s);

V_f is the volume of fluid within the oscillating tube(s);

ρ_f is the density of fluid.

The mechanical stiffness or the spring constant of the oscillating tube arrangement depends on the design of the Coriolis flowmeter and the Young's modulus of elasticity of the tube material.

Formulae (6), (7), and (8) can be used to solve for the fluid density, which is given by:

$$\rho_f = \left\{ C / \left[V_f (2\pi f_{rf})^2 \right] \right\} - m_{tb} / m_f$$

rewritten as

$$\rho_f = K_1 + K_2 / (f_{rf})^2 \quad (9)$$

where

K_1 and K_2 are density calibration factors (coefficients) for the density measurement that are determined during the calibration process (see [7.6.2](#) and [7.6.3](#)).

NOTE K_1 and K_2 are influenced by temperature and are commonly compensated for by means of integral temperature measurement.

The frequency, f_{rf} , in Formula (9) is determined by measuring the period of the tube oscillation, T_{rf} , or by counting cycles, N_c , during a time window (gate), t_w :

$$f_{rf} = 1/T_{rf} \text{ or } f_{rf} = N_c/t_w \quad (10)$$

where

T_{rf} is the period of the oscillating tube;

N_c is the number of cycles;

t_w is the time window (gate).

7.3 Specific gravity of fluids

Dividing the fluid density at process conditions by the density of reference fluid at reference conditions, results in the specific gravity, SG:

$$SG = (\rho_f) / (\rho_{ref}) \quad (11)$$

where

ρ_f is the density of the fluid at metering conditions;

ρ_{ref} is the density of the reference fluid at reference conditions (normally pure water for liquids and air for gases).

NOTE The previous edition of this International Standard used the term, Relative Density for Specific Gravity. Some end users and International Standards use the term Relative Density. It is important that the reference conditions used by the manufacturers are stated clearly to help the user avoid confusion.

7.4 Density measurement uncertainty

Similar to mass flow measurement uncertainty (see 6.2), manufacturers also specify density measurement uncertainty which includes all combined effects, such as linearity, repeatability, and hysteresis. It is normally expressed as an absolute value in mass per unit volume (i.e. g/cm³ or kg/m³).

Uncertainty statements are usually given for reference conditions which are specified by the manufacturer. These reference conditions should include the ranges for temperature and pressure. Additional information should be provided on the density measurement uncertainty other than for the reference conditions, e.g. by specifying the influence of fluid pressure and temperature.

7.5 Factors affecting density measurement

7.5.1 Temperature

Temperature changes affect the density calibration factors due to temperature related material properties, hence compensation is necessary. Compensation for this effect is usually performed by the transmitter using the measured tube temperature. However, due to compensation errors, e.g. temperature measurement differences, the effect cannot be entirely eliminated. In order to minimize this effect in meeting the users' process measurement requirements, it might be necessary to adjust the density calibration of the flowmeter at the operating temperature. Large differences in temperature between the oscillating tube(s) and the ambient temperature can cause additional errors in temperature compensation. The use of insulation materials can minimize these effects.

NOTE In certain applications, e.g. cryogenic liquids, there can be a transient temperature influence, resulting from a step change in process temperature (thermal shock) that momentarily influences the density measurement.

7.5.2 Pressure

Coriolis flowmeter sensor designs vary significantly between manufacturers. Sensor designs for a manufacturer can vary depending on size and application. Some designs or flow sensor sizes can be more susceptible to pressure effects than other designs. Check with the manufacturer for recommendations and procedures to adjust the density calibration factor due to pressure effects.

7.5.3 Multiphase (Two phase)

The density of liquid mixtures, homogeneous mixtures of solids in liquids, or homogeneous mixtures of liquids with a low volumetric ratio of gas can be measured with Coriolis flowmeters.

NOTE The Coriolis flowmeter, when used as a densitometer, can only measure the aggregate density of the fluid medium.

7.5.4 Flow effect

The motion of a fluid can influence the density measurement. Fluid velocities that give rise to such an effect vary depending on the sensor size and design. To reduce the density measurement uncertainty, it might be advisable to perform the density calibration at the process flowing conditions. Some manufacturers offer automatic compensation for flow effects on density measurement.

7.5.5 Corrosion and erosion

Corrosion and erosion can affect the mass and stiffness of the oscillating tube(s). In applications where these effects are likely, care should be taken in specifying suitable materials and in selecting the most appropriate Coriolis flowmeter.

7.5.6 Coatings

Coatings from the process fluid affect the effective mass and might affect the stiffness of the oscillating tube. In applications where this effect is likely, regularly scheduled cleaning should be considered. The density measured is of the fluid and the coating.

7.5.7 Installation

In general, installation stresses do not influence the density measurement. However, for certain sensor designs, there can be an orientation effect.

Depending on the user's performance requirements it might be necessary to calibrate the Coriolis flowmeter density application in its intended final orientation, perform a field transfer type density calibration, or alternatively, a single point density alignment to the user's process density (see [7.6.3](#)).

7.6 Density calibration and adjustment

7.6.1 General

Coriolis flowmeters can be calibrated during manufacture and/or by a field transfer type density calibration or a single point density alignment to the user's process density.

Only single-phase clean fluids should be used for laboratory calibrations. The oscillating tubes should be clean and free of coating or deposits. Deviation from these requirements can result in significant measurement errors.

7.6.2 Manufacturer's density calibration

Coriolis flowmeters are frequently calibrated by the manufacturer for density measurement, usually using air and water as reference fluids. The density calibration factors determined by this procedure

should be provided by the manufacturer. Manufacturer's calibration references should be traceable to a national or international standard. It is preferred that manufacturer's calibration laboratories be accredited to ISO/IEC 17025.

The user's measurement performance requirements and process conditions can require a special density calibration with fluids at temperature above or below ambient temperature.

7.6.3 Field density calibration and adjustment

The user's measurement performance requirements and process conditions can require the Coriolis flowmeter's density application to be field transfer calibrated from a standard (reference meter) or a single point alignment to the user's process density. Field verification can be used to verify possible installation effects or process temperature effects. The user should know the density of the fluid within the flowmeter to the required uncertainty.

8 Volume flow measurement at metering conditions

8.1 General

Coriolis flowmeters directly measure fluid mass flow rate and density at metering conditions. However, there are applications where the advantages of a Coriolis flowmeter would be very beneficial, but the desired measurement is volume at metering conditions. Coriolis flowmeters can be effectively used for volume flow measurement.

8.2 Volume calculation

Density is defined as its mass per unit volume; therefore, volume can be calculated from mass and density as follows:

$$V = \frac{M}{\rho} \quad (12)$$

where

V is the total volume at metering conditions;

ρ is the density at metering conditions;

M is the total mass.

Formula (12) may be incorporated directly into the transmitter software provided the Coriolis flowmeter is of a type that can measure both mass and density (see [Clause 6](#) and [Clause 7](#)). In reality, the mass part of the above equation is measured as a function of time (mass flow rate) and therefore, the volume calculated is also a function of time:

$$q_v = q_m / \rho \quad (13)$$

where

q_v is the volume flow rate at metering conditions;

q_m is the mass flow rate at metering conditions.

The Coriolis flowmeter can then provide the calculated volume flow rate as an output signal. The calculated volume flow rate can also be integrated with respect to time to obtain the total volume.

NOTE The calculated volume flow is based on dynamic mass flow and dynamic density measurements made under process conditions. Volume flow in this form is therefore, also a dynamic measurement under process conditions, not under reference conditions.

8.3 Gas as a process fluid

At low pressure, the Coriolis gas density measurement has greater uncertainty because the gas has very low density. Therefore, according to Formulae (12) and (13), the calculation of volume flow at gas metering conditions also have greater uncertainty.

8.4 Volume measurement uncertainty

Some Coriolis flowmeter manufacturers publish their expected measurement error for volume flow. However, if this information is not available, the expected uncertainty for volume flow measurement can be calculated using Formula (14):

$$U_v = \left((U_m)^2 + (U_\rho)^2 \right)^{1/2} \quad (14)$$

where

U_v is the uncertainty of the volume flow measurement;

U_m is the uncertainty of the mass flow measurement (see [6.2](#));

U_ρ is the uncertainty of the density measurement (see [7.4](#)).

All the above values of uncertainty are expressed in terms of percent of the reading.

8.5 Special influences

8.5.1 General

Coriolis flowmeters can only give a computed value of the volume and as such, the reliability can be only as good as the data entered into the volume formula. On this basis, any variation in the fluid or in process parameters which might have an influence on the reliability of mass flow and density measurements has a combined effect on the reliability of the calculated volume measurement. For specific effects of variations in process conditions on mass flow and density measurements, see [Clause 6](#) and [Clause 7](#).

8.5.2 Empty pipe effect

A Coriolis flowmeter measuring liquid flow responds to tubes becoming empty or liquid being displaced by vapour by a drop in the density reading falling close to zero. If this were to occur while there was still a small indicated mass flow present, the calculation of the liquid volume according to Formula (12) would be erroneously high. This problem can be avoided by incorporating a suitable low-density cut-off setting, designed to inhibit any flow measurement being performed unless the flowmeter is properly filled with liquid. Consultation with manufacturers can provide alternative methods of eliminating this problem.

8.5.3 Multiphase fluids

Volumes cannot be measured reliably under multiphase process conditions.

8.6 Factory calibration

8.6.1 Mass flow and density

When comparing a Coriolis flowmeter volume output with a reference volume standard, one is not able to distinguish between the uncertainty of the instrument's mass flow measurement and the uncertainty of the density measurement. Therefore, for calibration purposes, Coriolis flowmeters should always be considered as mass flow and density measuring devices.

These two parameters should first be calibrated in accordance with the recommendations given in [Clause 6](#) and [Clause 7](#), before the flow can be used for volumetric measurements. Once the flowmeter has been calibrated for mass flow and density, a theoretical prediction of the volume uncertainty can be determined using Formula (13).

8.7 Volume check

The expected value of uncertainty for volume measurement can be checked by performing a volumetric test against a known volume standard. In addition to the standard calibration certificate, on request, manufacturers should be able to provide test data showing volume flow rates and corresponding volumetric errors. These errors can be determined using the mass flow calibration data and the precise calibration fluid density. The volume determination can also be checked by means of a field test, which should be performed using the Coriolis flowmeter in its operational installation using the process fluid.

Annex A (informative)

Calibration techniques

A.1 Introduction

Coriolis flowmeters are calibrated in a manner similar to flowmeters. Calibration involves comparing the output of the flowmeter under test with a suitable standard. Coriolis flowmeters are available with analog, frequency, and digital output signals. There are two levels of calibration, described in detail in Annex [A.2](#), as follows:

- 1) Type 1: standard calibration — the details of which are specified by the manufacturer;
- 2) Type 2: special calibration — the details of which are specified by the user.

Coriolis flowmeters should be calibrated using mass reference techniques. However, volumetric methods can also be used, provided the overall uncertainties of the mass flow measurement include the uncertainty of both volume and density measurements. The uncertainty calculation should be performed in accordance with ISO 5168. Coriolis flowmeters measure mass; therefore, quantities of fluid measured during a gravimetric calibration should ultimately be expressed in units of mass and corrected for buoyancy.

A.2 Calibration methods

A.2.1 General considerations

When calibrating Coriolis flowmeters, it is advisable to collect data from the transmitter output(s) which is (are) independent of any output damping settings. Sufficient data shall be collected during the test to establish an acceptable calibration uncertainty.

There are three main methods for calibrating flowmeters: gravimetric, volumetric, and by use of a master meter. In each case, two operational techniques can be used.

- 1) Dynamic (flying) start/stop — data collection starts and stops while the fluid is maintained at a stable flow rate. The transmitter-signal processing time can result in a delay in the output. This should be taken into consideration when using a dynamic method in which small amounts of liquid are measured, for instance small volume provers and diverter-based test facilities.
- 2) Static start/stop — data collection starts and stops at zero flow conditions. In this case, the run time should be sufficiently long to account for errors induced by flow rate variations at the start and end of the run. The transmitter-signal processing time can result in a lag in the output. Therefore, even after the valve has been closed and the flow has stopped, the meter's electronics can continue to indicate flow. Errors due to this output can be reduced by delaying the close gate signal on the mass flow accumulation for a short period after the flow has stopped.

A.2.2 Gravimetric methods

The test fluid should be collected in a weighing vessel. The mass of the vessel should be recorded before the test starts and after the test is completed. The difference between these two readings is the collected mass and in the case where air or gas is displaced, the collected mass should be corrected for buoyancy. Care should be taken to avoid evaporation and the formation of condensation on the tank walls. Calibration is made by comparing the transmitter totalizer with the collected mass.

A.2.3 Volumetric

The Coriolis flowmeter can be calibrated using an established volumetric method, for instance collecting the test fluid in a certified vessel or using a volume prover. However, the collected quantity (volume) should be converted into mass by multiplication by the fluid density. The density can be measured dynamically using an online densitometer or, if the fluid density is constant, by sampling methods. If the properties of the fluid are well known, the density can also be determined by measuring the fluid temperature and pressure within the vessel.

A.2.4 Master-meter (reference meter)

A master-meter can also be used to calibrate a Coriolis flowmeter using established methods. The uncertainty of the master-meter should be documented. If the master-meter is a volumetric device, its measurement should be converted to mass using the fluid density. The density can be measured dynamically using an online densitometer or, if the fluid density is constant, using sampling methods. If the properties of the fluid are well known, the density can also be determined by measuring the fluid temperature and pressure during the test.

A.2.5 Calibration frequency

A Coriolis flowmeter should not drift if it is correctly installed and used with clean, non-abrasive fluids. The frequency of calibration of the flowmeter is governed by the criticality and nature of the operating conditions. It might be appropriate to reduce or increase the frequency of calibration as data are gathered. For fiscal and/or custody transfer applications, this frequency can be prescribed by regulation, or agreed between the relevant parties.

If the flowmeter installation conditions vary, for instance as a result of pipe work modification in the vicinity of the flowmeter, the flowmeter zero offset value should be verified. A zero adjustment is needed if the flowmeter output at zero flow conditions is greater than the meter zero stability specified by the manufacturer. This can be corrected by conducting a zero adjustment (see [4.2.9](#)).

A.3 Calibration procedures

The procedures adopted for all flowmeter calibration methods shall ensure the following:

- a) the flowmeter is installed in accordance with manufacturer's recommendations;
- b) the flowmeter under test, and the connecting piping, is filled completely with test fluid before and after the test to prevent any effects from air;
- c) the calibration is preceded by an appropriate warm-up period and hydraulic run-in time;
- d) all transmitter configuration data are recorded prior to the start of the test;
- e) the test flow rates are selected to cover the operating flow range of the flowmeter.

A.4 Calibration conditions

a) Zero adjustment

First, a zero flow condition should be established (and checked) in the test rig. If the flowmeter output at zero flow conditions is within the zero stability value specified by the manufacturer, a zero adjustment will not be necessary. However, if the output at zero flow conditions is seen to be unsatisfactory, a zero adjustment, per manufacturer's procedures, should be made only at the start of the calibration and not between runs. It is recommended that the fluid conditions be recorded as part of the zero adjustment. However, if the output at zero flow conditions is seen to be unsatisfactory, a zero adjustment according to manufacturer specified procedures should be made only at the start of the calibration and not between runs.

b) **Flow stability**

The flow shall be kept stable to within ± 5 % of the selected flow rate for the duration of the calibration test at that flow rate.

c) **Temperature and pressure**

Variations in fluid temperature and pressure should be minimized during the calibration process. For a single run, the temperature should be held constant to within 1 °C, and to within 5 °C for the entire duration of the calibration. The fluid pressure within the test rig should be kept sufficiently high to avoid flashing or cavitation in the flowmeter and/or in the vicinity of the flowmeter.

d) **Density and viscosity**

Depending on the Coriolis flowmeter design, the performance can be affected by variations in fluid density and viscosity. In these cases, test fluids should be used having properties that are the same or similar to the process fluid for which the flowmeter is intended.

e) **Installation**

The recommendations outlined in [4.2](#) are also applicable to the flowmeter installation during calibration.

A.5 Calibration certificate information

The following data are examples of items that shall be included on a flowmeter calibration certificate:

- 1) the unique attributed certificate number, repeated on each page along with the page number and the total number of pages;
- 2) the certificate date of issue and the test date if it differs from the certificate date of issue;
- 3) the identity of the party commissioning the test;
- 4) the name and location of the test laboratory;
- 5) the test fluid data, such as product name or density, temperature, and pressure;
- 6) the unique identification of flowmeter under test;
- 7) the traceability of the test facility and its procedures;
- 8) the uncertainty statement and calculation method;
- 9) the relevant ambient conditions:
 - a) the relevant test data and the results of the calibration, including flowmeter output at zero flow at start and finish of calibration;
 - b) the calibration data should be presented in chronological order;
 - c) the configuration data within the transmitter at which the calibration is performed;
 - d) the authorized signature.

Annex B (informative)

Safety guidelines for the selection of Coriolis flowmeters

B.1 General considerations

When the Coriolis flowmeter is used in critical applications for the measurement of flammable or toxic substances, care shall be taken to verify that the integrity of the flowmeter can be maintained up to test pressure over the expected lifetime under true process conditions.

It is generally thought that because Coriolis flowmeters have thin-walled vibrating tubes, they are vulnerable to stress fatigue resulting in tube failure. This is a common misconception and has often led to a gross over-specification of these flowmeters or in some cases, their avoidance altogether.

Experience amongst manufacturers demonstrates that when used in normal operation, the stresses induced within a Coriolis flowmeter are too small to instigate fatigue.

When Coriolis flowmeters are specified for a particular application, special attention shall be given to the following specific areas.

B.1.1 Materials

Care shall be taken to establish that suitable wetted materials are selected for compatibility with the process fluid(s) being metered including cleaning fluids. Material incompatibility is the most common source of Coriolis flowmeter tube fracture and can be totally avoided at the sensor selection stage. Standard material guides do not necessarily apply to thin-walled, vibrating tubes. Manufacturers' recommendations shall be considered as well as standard material guides.

B.1.2 Velocity

Care shall be taken to ensure that no erosion takes place within the oscillating tube(s) when measuring the flow of abrasive products. Thinning of the measuring tube through erosion can eventually lead to catastrophic failure. Manufacturers should be able to specify the maximum flow velocity not subject to erosion for a given sensor size.

B.1.3 Tube pressure rating

In order to guarantee conformance for the tube pressure rating, the manufacturer should provide the following information:

- a) ASME codes to which the tubes have been designed, usually ANSI/ASME B31.3 (or recognized equivalent standard such as AD-Merkblätter, Druckbehälterverordnung/Germany or KHK/Japan);
- b) the design calculations pertaining to the codes mentioned in a), for the wall thickness and pressure ratings.

B.1.4 Flange pressure rating

Similarly, appropriate ASME design codes shall be available for checking the suitability of the connections to the Coriolis flowmeter sensor.

B.1.5 Pressure testing

Evidence shall be available from the manufacturer to confirm that the full-assembled sensor has passed an appropriate pressure test. This evidence shall be available in terms of a certificate or a test procedure.

When the above criteria can be fulfilled for any given use, secondary containment should not be necessary.

B.2 Secondary containment

B.2.1 Appropriate use

While the principles laid down in [B.1.1](#) to [B.1.5](#) serve as safety guidelines for flowmeter selection, there might be situations where all of the above-mentioned criteria cannot be satisfied. For example, if some concern remains regarding material compatibility due to the unknown nature of the process fluids which will pass through the flowmeter, then secondary containment might be required. In this case, the following issues shall be addressed regarding the integrity of the secondary containment offered.

B.2.2 Design integrity

Evidence shall be available from the manufacturer demonstrating that the containment vessel has been designed specifically for the given purpose and in accordance with a recognized standard.

B.2.3 Pressure testing

In addition to the provision of design calculations demonstrating the suitability of a containment vessel, it might be necessary for manufacturers to perform tests on the fully assembled containment vessel. Such pressure tests shall be conducted using suitable purge connections in the containment case. Tests shall conform to an established procedure and shall be supported by the necessary documentation and test certificates.

B.2.4 Selection of appropriate secondary-containment pressure ratings

General guidelines for specifying the pressure rating of secondary containment vessels are as follows:

- a) maximum continuous containment pressure > process relief pressure;
- b) containment burst pressure > plant design pressure.

All secondary-containment pressure ratings (requirements) are to meet local or national regulations.

The secondary containment of a Coriolis flowmeter is only subjected to pressure under abnormal conditions (tube fracture), which would, from necessity, be for a limited duration and a single occurrence. On this basis, it might be possible to accept a pressure specification for the containment vessel of the Coriolis flowmeter which is less rigorous than that of the rest of the pipework. Such compromises shall only be made within design and/or test code requirements.

In cases where the process design pressure is higher than that of the secondary containment pressure, the safety of the Coriolis flowmeter installation can be enhanced by installing a bursting disc or relief valve can.

Annex C (informative)

Considerations for multi-component liquid systems

C.1 General

The density measurement made by a Coriolis flowmeter is a function of the composite density of the process fluid in the tube(s). If the fluid contains two components and the density of each component is known, the mass or volume fraction of each component can be determined.

By combining the (independent) mass flow rate and density (or concentration) measurements, the net mass flow of each component of a two-component mixture can also be calculated. Net flow measurements are limited to two-component systems, for instance oil and water, and are useful in a wide variety of applications. For example, flow rates of each component of two-component systems such as water-and-oil mixtures, liquid-and-solid slurries, sugar measurements, and other two-component systems can be determined using a Coriolis flowmeter.

Theoretically, a Coriolis flowmeter measures the average density of multi-component fluids, including two-phase systems. This is generally true in the case of slurries (solids carried by a liquid). However, measurements of a gas phase in a liquid stream, or conversely, a liquid in a gas stream, can be difficult to make due to structural influences within the sensing element. Consult the manufacturer if two-phase flow is to be measured.

C.2 Immiscible mixtures

C.2.1 General

An immiscible liquid is a liquid containing two components which do not mix. The total volume is the sum of the individual volumes at metering conditions.

When two components do not mix, whether they be two immiscible liquids or a liquid and a solid, the relationship between density and concentration can only be defined by Formulae (C.1) and (C.2) given in Annex [C.2.2](#). Examples of these types of mixtures are starch and water, sand and water, and oil and water.

C.2.2 Mass fraction

Formulae (C.1) and (C.2) describe the relationship between component A and component B, respectively, as a mass fraction w expressed as a percentage.

$$w_A = 100 \left\{ \frac{[\rho_A (\rho_{ms} - \rho_B)]}{[\rho_{ms} (\rho_A - \rho_B)]} \right\} \quad (C.1)$$

$$w_B = 100 \left\{ \frac{[\rho_B (\rho_A - \rho_{ms})]}{[\rho_{ms} (\rho_A - \rho_B)]} \right\} \quad (C.2)$$

where

w_A and w_B are W the respective mass fractions of component A and component B in relation to the mixture;

ρ_A and ρ_B are the respective densities of component A and component B;

ρ_{ms} is the measured density of the mixture.

C.2.3 Volume fraction

Formulae (C.3) and (C.4) describe the relationship between component A and component B, as a volume fraction φ expressed as a percentage.

$$\varphi_A = 100(\rho_{ms} - \rho_B)/(\rho_A - \rho_B) \quad (C.3)$$

$$\varphi_B = 100(\rho_A - \rho_{ms})/(\rho_A - \rho_B) \quad (C.4)$$

where

φ_A and φ_B are the respective volume fractions of component A and component B in relation to the mixture;

ρ_A , ρ_B , and ρ_{ms} are defined in Formulae (C.1) and (C.2).

The volume fraction is a simple rearrangement of Formulae (C.1) and (C.2).

C.2.4 Net mass flow rate

By combining the total mass flow rate and the mass fraction measurements, the net mass flow rate of each of two components can be calculated as follows:

$$q_{mA} = (q_{mT})(w_A)/100 \quad (C.5)$$

$$q_{mB} = (q_{mT})(w_B)/100 \quad (C.6)$$

where

q_{mT} is the total mass flow rate of the mixture;

q_{mA} and q_{mB} are net mass flow rate of components A and B, respectively;

w_A and w_B are defined in Formulae (C.1) and (C.2).

C.2.5 Net volume flow rate

By combining the total volume flow rate and volume fraction measurements, the net volume flow rate of each of two components can be calculated.

$$q_{vA} = (q_{vT})(\varphi_A)/100 \quad (C.7)$$

$$q_{vB} = (q_{vT})(\varphi_B)/100 \quad (C.8)$$

where

q_{vT} is the net total volume flow rate;

q_{vA} and q_{vB} are the net volume flow rate of components A and B, respectively;

φ_A and φ_B are defined in Formulae (C.3) and (C.4).

C.3 Special considerations for temperature and pressure

The previous formulae and discussions (as well as those in [Annex D](#)) assume constant temperature and pressure conditions. In any mixture, temperature and pressure affect the density of each of the two components differently. Therefore, corrections are required. Typically, pressure has a small influence on the liquid density and can be considered negligible, particularly if the pressure is almost constant. Any influence can be characterized by making a calibration. Temperature has a much larger influence and online corrections are necessary. Coriolis flowmeters provide temperature measurement for material property corrections of the sensing element. This is a convenient measurement to use for liquid property corrections within the transmitter; however, it might be necessary to make a separate temperature measurement for low uncertainty applications.

Annex D (informative)

Miscible liquids containing chemically non-interacting components

D.1 Miscible liquids containing chemically non-interacting components

A miscible liquid consists of two components which mix completely or dissolve together and the total volume of the liquid can be different from the sum of the individual volumes at metering conditions.

When two liquids are completely miscible, such as alcohol and water, the mass fraction (of either liquid component) versus density is usually read from table values. It is not possible to obtain a general formula valid for all miscible liquids due to the nonlinear relationship between mass fraction and density. It is necessary to derive a formula for each mixture.

D.1.1 Relationship between density and mass fraction

[Figure D.1](#) is an example of the relationship between density and mass fraction for two miscible liquids; water and ethanol at 20 °C.

Pure water and pure ethanol have the following densities:

- water: 0,998 23 g/cm³;
- ethanol: 0,789 34 g/cm³.

For example, a density of 0,789 34 g/cm³ is given for a mass fraction of 100 % ethanol and a density of 0,998 23 g/cm³ for a mass fraction of 0 % ethanol (or 100 % water) in [Figure D.1](#). Other intermediate values of density can be determined from the nonlinear curve given in [Figure D.1](#).

Data taken from Reference [2].

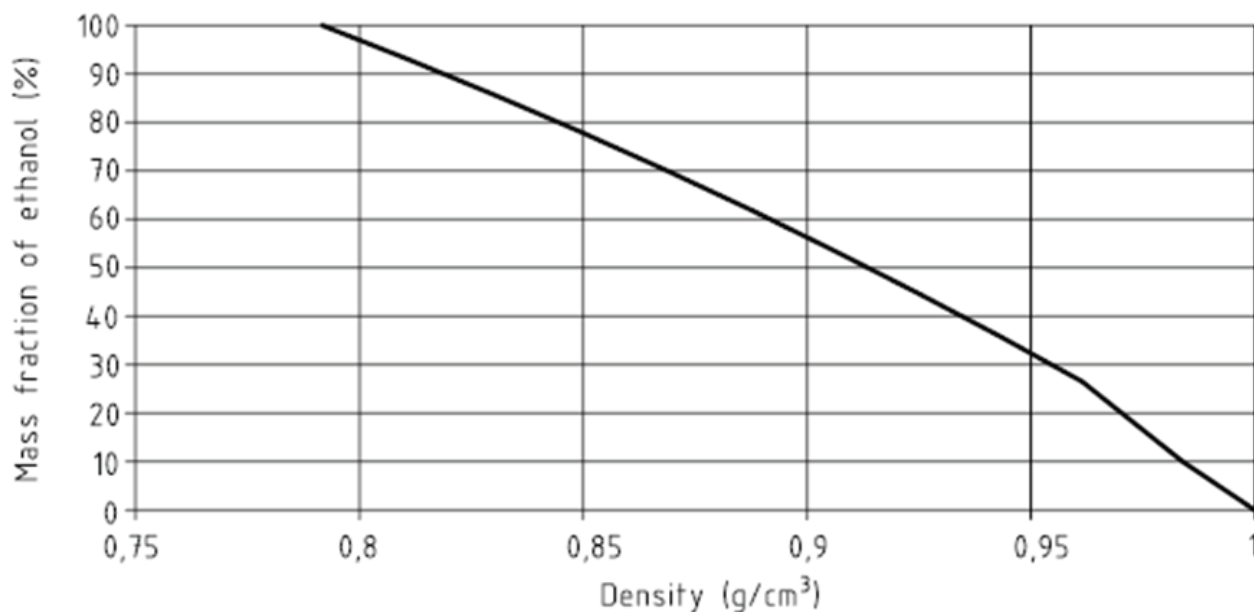

Figure D.1 — Mass fraction versus density curve for ethanol and water

D.1.2 Mass fraction

The value of mass fraction, expressed as a percentage, is determined directly from table values or the curve fit of a graph similar to [Figure D.1](#).

D.1.3 Volume fraction

The net volume of two components that are soluble is difficult to quantify in absolute terms. If a volume of component A and a volume of component B are mixed, the resulting volume does not equal the sum of volume A and volume B. This results from a change in the interstitial occupancy of solute molecules in the mixture. In practice, users might need to know the volume fraction before mixing for better volume-flow control.

$$\varphi_A = 100(w_A/\rho_A)/[(w_A/\rho_A)+(w_B/\rho_B)] \quad (D.1)$$

$$\varphi_B = 100(w_B/\rho_B)/[(w_A/\rho_A)+(w_B/\rho_B)] \quad (D.2)$$

where

φ_A is the volume fraction of component expressed as a percentage;

w_A , w_B , ρ_A , and ρ_B are defined in [Annex C](#).

D.1.4 Net flow calculation

Once the mass or volume fractions are known, net mass and volume flow calculations are identical to those given in [C.2.4](#) and [C.2.5](#).

D.2 Miscible liquids containing chemically interacting components

D.2.1 Relationship between density and mass fraction

The relationship between two soluble liquids which chemically interact is complex. An example is sulphuric acid and water; the acid ionization changes the solution density. As shown in [Figure D.2](#), the relationship between concentration and density is not defined by a simple curve, i.e. a single density value can correlate to two different values of mass fraction. In such cases, it is important for the user to understand the relationship between density and mass fraction and to work within a sufficiently narrow range of mass fraction in order to correlate a single value curve for density.

Data taken from the CRC Handbook[2].

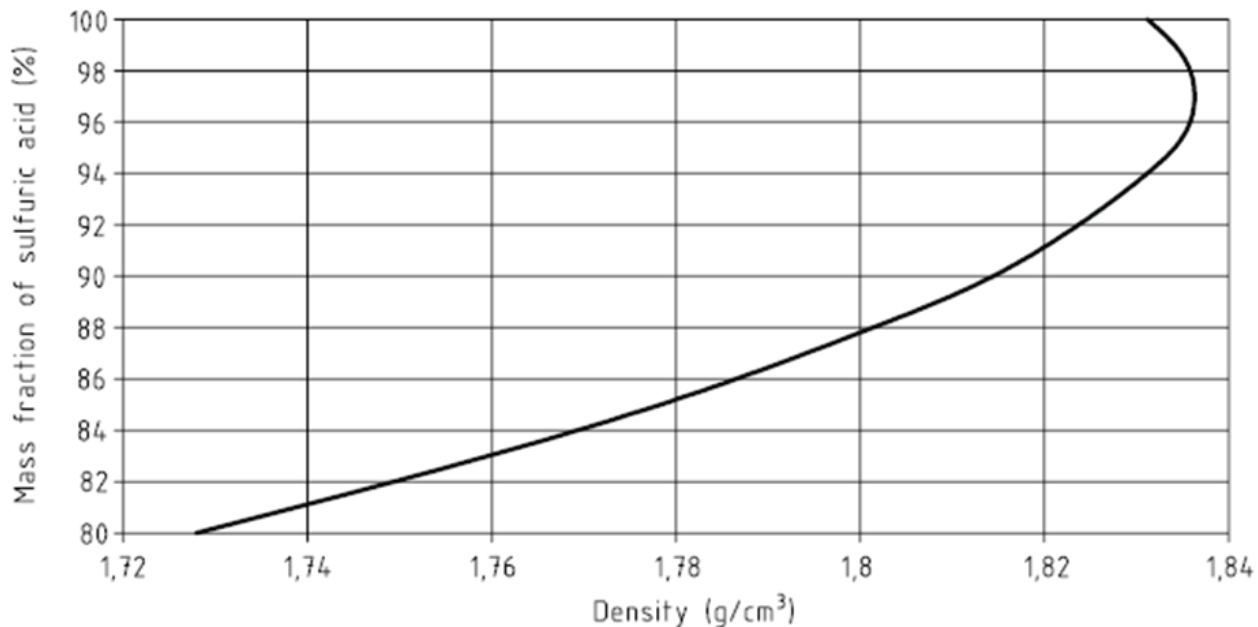

Figure D.2 — Mass fraction of sulphuric acid versus density

D.2.2 Mass fraction

The value of mass fraction, expressed as a percentage, is read directly from table values or the curve fit of a graph similar to [Figure D.2](#).

D.2.3 Volume fraction

The determination of volume fraction, expressed as a percentage, before mixing is calculated in the same as that described in [D.1.3](#)

D.2.3.1 Net flow calculation

Once the mass or volume fractions are known, net mass and volume flow calculations are identical to those given in [C.2.4](#) and [C.2.5](#).

Bibliography

- [1] ANSI/ASME B31.3, *Process Piping*
- [2] Handbook of Chemistry and Physics (CRC), CRC Press, ISO, 57th ed., 1976-1977

British Standards Institution (BSI)

BSI is the national body responsible for preparing British Standards and other standards-related publications, information and services.

BSI is incorporated by Royal Charter. British Standards and other standardization products are published by BSI Standards Limited.

About us

We bring together business, industry, government, consumers, innovators and others to shape their combined experience and expertise into standards-based solutions.

The knowledge embodied in our standards has been carefully assembled in a dependable format and refined through our open consultation process. Organizations of all sizes and across all sectors choose standards to help them achieve their goals.

Information on standards

We can provide you with the knowledge that your organization needs to succeed. Find out more about British Standards by visiting our website at bsigroup.com/standards or contacting our Customer Services team or Knowledge Centre.

Buying standards

You can buy and download PDF versions of BSI publications, including British and adopted European and international standards, through our website at bsigroup.com/shop, where hard copies can also be purchased.

If you need international and foreign standards from other Standards Development Organizations, hard copies can be ordered from our Customer Services team.

Subscriptions

Our range of subscription services are designed to make using standards easier for you. For further information on our subscription products go to bsigroup.com/subscriptions.

With **British Standards Online (BSOL)** you'll have instant access to over 55,000 British and adopted European and international standards from your desktop. It's available 24/7 and is refreshed daily so you'll always be up to date.

You can keep in touch with standards developments and receive substantial discounts on the purchase price of standards, both in single copy and subscription format, by becoming a **BSI Subscribing Member**.

PLUS is an updating service exclusive to BSI Subscribing Members. You will automatically receive the latest hard copy of your standards when they're revised or replaced.

To find out more about becoming a BSI Subscribing Member and the benefits of membership, please visit bsigroup.com/shop.

With a **Multi-User Network Licence (MUNL)** you are able to host standards publications on your intranet. Licences can cover as few or as many users as you wish. With updates supplied as soon as they're available, you can be sure your documentation is current. For further information, email bsmusales@bsigroup.com.

BSI Group Headquarters

389 Chiswick High Road London W4 4AL UK

Revisions

Our British Standards and other publications are updated by amendment or revision.

We continually improve the quality of our products and services to benefit your business. If you find an inaccuracy or ambiguity within a British Standard or other BSI publication please inform the Knowledge Centre.

Copyright

All the data, software and documentation set out in all British Standards and other BSI publications are the property of and copyrighted by BSI, or some person or entity that owns copyright in the information used (such as the international standardization bodies) and has formally licensed such information to BSI for commercial publication and use. Except as permitted under the Copyright, Designs and Patents Act 1988 no extract may be reproduced, stored in a retrieval system or transmitted in any form or by any means – electronic, photocopying, recording or otherwise – without prior written permission from BSI. Details and advice can be obtained from the Copyright & Licensing Department.

Useful Contacts:

Customer Services

Tel: +44 845 086 9001

Email (orders): orders@bsigroup.com

Email (enquiries): cservices@bsigroup.com

Subscriptions

Tel: +44 845 086 9001

Email: subscriptions@bsigroup.com

Knowledge Centre

Tel: +44 20 8996 7004

Email: knowledgecentre@bsigroup.com

Copyright & Licensing

Tel: +44 20 8996 7070

Email: copyright@bsigroup.com



...making excellence a habit.™