



BSI Standards Publication

Fine ceramics (advanced ceramics, advanced technical ceramics) — Determination of photocatalytic activity of surfaces in an aqueous medium by degradation of methylene blue

NO COPYING WITHOUT BSI PERMISSION EXCEPT AS PERMITTED BY COPYRIGHT LAW

National foreword

This British Standard is the UK implementation of ISO 10678:2010.

The UK participation in its preparation was entrusted to Technical Committee RPI/13, Advanced technical ceramics.

A list of organizations represented on this committee can be obtained on request to its secretary.

This publication does not purport to include all the necessary provisions of a contract. Users are responsible for its correct application.

© BSI 2010

ISBN 978 0 580 63644 8

ICS 81.060.30

Compliance with a British Standard cannot confer immunity from legal obligations.

This British Standard was published under the authority of the Standards Policy and Strategy Committee on 31 October 2010.

Amendments issued since publication

Date	Text affected
------	---------------

INTERNATIONAL STANDARD

BS ISO 10678:2010

ISO
10678

First edition
2010-09-15

Fine ceramics (advanced ceramics, advanced technical ceramics) — Determination of photocatalytic activity of surfaces in an aqueous medium by degradation of methylene blue

*Céramiques techniques — Détermination de l'activité photocatalytique
des surfaces dans un milieu aqueux par dégradation du bleu de
méthylène*



Reference number
ISO 10678:2010(E)

© ISO 2010

PDF disclaimer

This PDF file may contain embedded typefaces. In accordance with Adobe's licensing policy, this file may be printed or viewed but shall not be edited unless the typefaces which are embedded are licensed to and installed on the computer performing the editing. In downloading this file, parties accept therein the responsibility of not infringing Adobe's licensing policy. The ISO Central Secretariat accepts no liability in this area.

Adobe is a trademark of Adobe Systems Incorporated.

Details of the software products used to create this PDF file can be found in the General Info relative to the file; the PDF-creation parameters were optimized for printing. Every care has been taken to ensure that the file is suitable for use by ISO member bodies. In the unlikely event that a problem relating to it is found, please inform the Central Secretariat at the address given below.



COPYRIGHT PROTECTED DOCUMENT

© ISO 2010

All rights reserved. Unless otherwise specified, no part of this publication may be reproduced or utilized in any form or by any means, electronic or mechanical, including photocopying and microfilm, without permission in writing from either ISO at the address below or ISO's member body in the country of the requester.

ISO copyright office
Case postale 56 • CH-1211 Geneva 20
Tel. + 41 22 749 01 11
Fax + 41 22 749 09 47
E-mail copyright@iso.org
Web www.iso.org

Published in Switzerland

Contents

Page

Foreword	iv
1 Scope	1
2 Terms and definitions	1
3 Symbols and units	2
4 Principle.....	3
5 Apparatus	3
6 Calibration	3
7 Measuring and conditioning solution	3
8 Sample preparation	4
9 Preparation of the measurement	4
10 Procedure of the measurement	5
11 Evaluation of results	6
12 Precision.....	7
13 Test report.....	7
Annex A (informative) Example of a data evaluation	8
Annex B (informative) Examples of suitable measuring devices	9
Annex C (informative) Results of the inter-laboratory test.....	11
Bibliography.....	12

Foreword

ISO (the International Organization for Standardization) is a worldwide federation of national standards bodies (ISO member bodies). The work of preparing International Standards is normally carried out through ISO technical committees. Each member body interested in a subject for which a technical committee has been established has the right to be represented on that committee. International organizations, governmental and non-governmental, in liaison with ISO, also take part in the work. ISO collaborates closely with the International Electrotechnical Commission (IEC) on all matters of electrotechnical standardization.

International Standards are drafted in accordance with the rules given in the ISO/IEC Directives, Part 2.

The main task of technical committees is to prepare International Standards. Draft International Standards adopted by the technical committees are circulated to the member bodies for voting. Publication as an International Standard requires approval by at least 75 % of the member bodies casting a vote.

Attention is drawn to the possibility that some of the elements of this document may be the subject of patent rights. ISO shall not be held responsible for identifying any or all such patent rights.

ISO 10678 was prepared by Technical Committee ISO/TC 206, *Fine ceramics*.

Fine ceramics (advanced ceramics, advanced technical ceramics) — Determination of photocatalytic activity of surfaces in an aqueous medium by degradation of methylene blue

1 Scope

This International Standard specifies a method for the determination of the photocatalytic activity of surfaces by degradation of the dye molecule methylene blue (MB) in aqueous solution using artificial ultraviolet (UV) radiation, and characterizes the ability of photoactive surfaces to degrade dissolved organic molecules on ultraviolet radiation.

The test method specified is also applicable to evaluation of the specific photocatalytic self-cleaning activity of surfaces covered with respective coatings.

This method is not applicable to characterizing the photoactivity of surfaces on visible illumination, regarding direct soiling, degradation of gaseous molecules and the determination of antimicrobial photoactivity of surfaces.

NOTE Correlations between these different kinds of photocatalytic activity can, however, exist, in particular at surfaces exhibiting low photonic efficiencies.

2 Terms and definitions

For the purposes of this document, the following terms and definitions apply.

2.1

specific photocatalytic activity

P_{MB}
measure of the photochemical conversion

NOTE Specific photocatalytic activity is expressed in moles per square metre and hour [mol/(m²h)].

2.2

photonic efficiency

ζ_{MB}
measure of the selectivity of the incident photons to induce the decolourization of methylene blue

NOTE 1 Photonic efficiency is expressed as a percentage of the incident photon flux.

NOTE 2 It is assumed that one photon can induce the decolourization of one dye molecule.

2.3

test solution

aqueous methylene blue solution used to determine the photocatalytic activity of surfaces

2.4
measuring solution

part of **test solution** (2.3) with a volume of $\leq 10\%$ of the volume of the test solution used for external determination of the optical absorbance employing a spectrophotometer

2.5
conditioning solution

aqueous methylene blue solution used for the pre-adsorption of methylene blue on the test surfaces prior to the determination of the photocatalytic activity of surfaces

3 Symbols and units

For the purposes of this document, the symbols and units in Table 1 apply.

Table 1 — Symbols and units

Designation	Symbol	Unit
Planck's constant ($h = 6,626 \times 10^{-34}$ Js)	h	Js
Avogadro number ($N_A = 6,022 \times 10^{23}$ 1/mol)	N_A	1/mol
Relative molar mass	M	g/mol
Molar extinction coefficient	ϵ	m^2/mol
Time	t	h
Time of measurement	t_m	h
Concentration	c	mol/l
Absorbance	A_λ	unitless
Length	d	cm
Volume of test solution	V	l
Irradiated area	A	m^2
Wavelength	λ	m
UV-radiation intensity	E	W/m^2
Average UV-radiation intensity	$E_{av} = \frac{\int E dt}{t_m}$	W/m^2
Specific degradation rate	$R = \frac{\Delta A_\lambda V}{\Delta t \epsilon d A}$	$\text{mol}/(\text{m}^2\text{h})$
Specific degradation rate with UV radiation	$R_{irr} = \frac{\Delta A_{\lambda, irr} V}{\Delta t \epsilon d A}$	$\text{mol}/(\text{m}^2\text{h})$
Specific degradation rate without UV radiation	$R_{dark} = \frac{\Delta A_{\lambda, dark} V}{\Delta t \epsilon d A}$	$\text{mol}/(\text{m}^2\text{h})$
Specific photoactivity	$P_{MB} = R_{dark} - R_{irr}$	$\text{mol}/(\text{m}^2\text{h})$
Photonic UV-radiation intensity	$E_P = \frac{\lambda_{max} E_{av}}{hc N_A} \times 3\,600$	$\text{mol}/(\text{m}^2\text{h})$
Average photonic UV-radiation intensity	$E_{P, av}$	$\text{mol}/(\text{m}^2\text{h})$
Photonic efficiency	$\zeta_{MB} = \frac{P_{MB}}{E_P} \times 100$	%

4 Principle

Methylene blue is degraded in an aqueous solution that is in contact with the potentially photocatalytically active surface by UV radiation of this surface through the solution, with light not capable of inducing the direct photolysis of the dye ($320 \text{ nm} \leq \lambda \leq 400 \text{ nm}$), with the overall result being the decolourization of the solution. The amount of dye remaining in the solution is determined at regular intervals during the UV-radiation period using UV/visible (vis)-spectroscopy. A reference measurement is either performed with the same sample without UV radiation or with an identical sample in a second container with the photoactive surface protected by a cover from the incident light beam. The results are used to calculate the specific degradation rates and the respective photonic efficiencies characteristic of the surface tested.

5 Apparatus

5.1 General

Apparatus that will be in contact with the methylene blue solution shall be made from materials exhibiting no or just a very small tendency to adsorb this dye on its surface, e.g. glass, stainless steel, polyethylene, polypropylene, polyacrylate, silicones with low organic emission. The test arrangement shall exhibit minimal stray light.

5.2 Measuring device, either two testing cylinders fixed on the sample surface by a suitable glue, or two testing cells, each consisting of a vessel with a sample holder (for a schematic diagram of a suitable measuring device, see Annex B).

5.3 Glass pane, to cover the measuring cell exhibiting minimal absorbance within the spectral emission region of the UV-radiation light source (5.4).

5.4 UV-radiation light source, i.e. a narrow-band emitter in the wavelength range between $\lambda = 320 \text{ nm}$ and $\lambda = 400 \text{ nm}$ (UV-A) with a UV-radiation intensity of $E = (10 \pm 0,5) \text{ W/m}^2$, measured at the height of the sample underneath the covering glass pane.

5.5 UV radiometer (sensor), to measure the UV-radiation intensity, calibrated to closely match the characteristic of the UV-radiation light source.

5.6 UV/vis-spectrophotometer, calibrated in the measuring range between $\lambda = 600 \text{ nm}$ and $\lambda = 700 \text{ nm}$, for the determination of methylene blue concentration.

5.7 Measurement cells, for the spectrophotometer made of glass or plastics, with an optical length of 10 mm and a transmittance $> 80 \%$ (600 nm to 700 nm).

6 Calibration

The apparatus according to 5.5 and 5.6, as well as the balances used, shall be calibrated following the instructions for equipment monitoring.

7 Measuring and conditioning solution

Aqueous methylene blue solutions shall be used for both the measurement and the conditioning. The methylene blue solutions shall be prepared freshly from stock solutions stored in the dark using distilled water in the absence of any other additives. The initial MB concentration c_0 for the test solution shall be $c_0 = (10 \pm 0,5) \mu\text{mol/L}$. The conditioning solution shall be prepared at a concentration of $c = (20 \pm 1) \mu\text{mol/L}$. The absorbance, A_λ , of the solutions shall be calculated using Equation (1):

$$A_\lambda = \varepsilon \times c \times d \quad (1)$$

NOTE 1 The absorbance amounts are $A_{\lambda, \max} = 0,74$ (for the test solution) and $A_{\lambda, \max} = 1,48$ (for the conditioning solution), at a measuring length of $d = 10$ mm.

NOTE 2 Methylene blue ($C_{16}H_{18}ClN_3S \times 3H_2O$; $M = 373,90$ g/mol) is a dye with a small absorbance in the wavelength range between $\lambda = 350$ nm and $\lambda = 450$ nm. MB has a molar extinction coefficient of $\epsilon(664 \text{ nm}) = 7402,8$ m²/mol in an aqueous solution at a concentration of $c = (10 \pm 0,5)$ $\mu\text{mol/L}$ (see Reference [2]).

8 Sample preparation

The sample shall have a geometrical surface area between (100 ± 1) mm² and $(1\,500 \pm 15)$ mm². It shall first be cleaned following the manufacturer's instructions. Following the last cleaning step, it shall be illuminated for 24 h to 72 h by UV light with a wavelength λ of $\lambda < 400$ nm and an UV-radiation intensity $E > 10$ W/m². If the apparatus shown in Figure B.1 is used, the amount of MB solution shall be $(35 \pm 0,3)$ mL.

Afterwards, two similar samples shall be conditioned by placing each of them in a separate vessel with conditioning solution (see Clause 7). Alternatively, this conditioning solution may be poured into a cylinder fixed onto the sample surface. This conditioning phase shall last for at least 12 h in the dark. If the dye concentration in the conditioning solution is lower than that of the test solution at the end of the conditioning period, the conditioning shall be repeated using a fresh conditioning solution.

9 Preparation of the measurement

If testing cells (see Figure B.2) are used, place both conditioned samples in the measuring device (5.2) with the test solutions (see Clause 7) and keep them in the dark.

Using testing cylinders fixed onto the sample surface, replace the conditioning solution with test solution at the time t_0 (see Figure 1). The height of the MB test solution above the photoactive surface shall be between 20 mm and 50 mm. The volume of the test solution shall be at least ten times greater than the volume of the measuring solution required for the measurement in the spectrophotometer. Exactly determine the total volume of the test solution.

NOTE For the fixed cylinder, the total volume of the test solution is usually 50 ml at a covered area of $A = 1\,000$ mm² and a filling height of 50 mm.

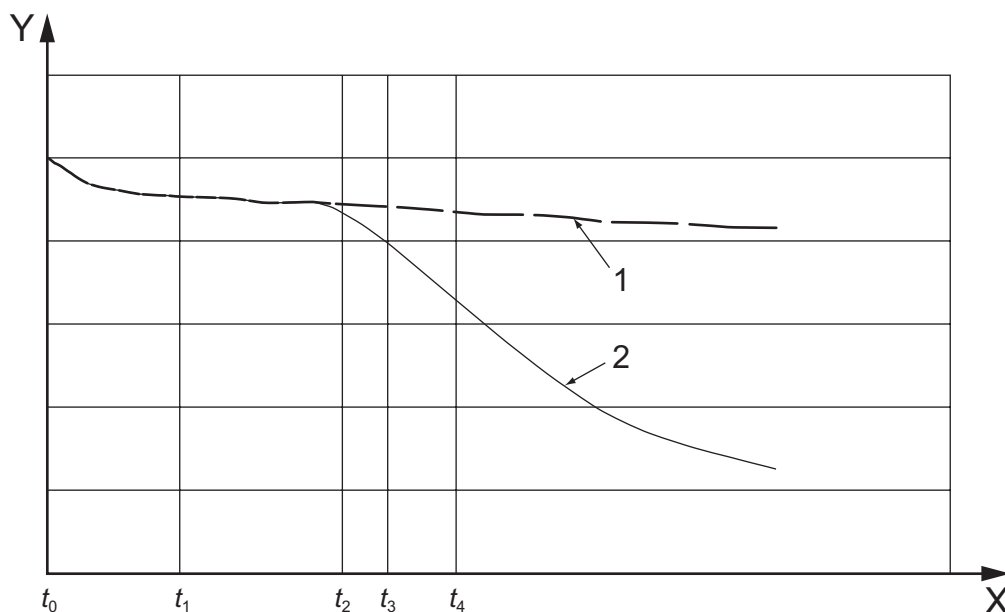
**Key**

- Y absorbance
 X time
 1 absorbance/time curve of the measuring solution in the dark (without UV radiation)
 2 absorbance/time curve of the measuring solution in the case of UV radiation

Figure 1 — Schematic of the obtained measuring curves**10 Procedure of the measurement**

Cover the measuring cells or cylinders with the UV transparent glass pane (5.3) during the whole test. Start the UV radiation of the sample if the absorbance/time curve of the test solution (see curves 1 and 2 in Figure 1) is nearly linear, i.e. in the range of t_1 to t_2 . The UV-radiation light source (5.4) shall be capable of maintaining a UV-radiation intensity of $E = (10 \pm 0,5) \text{ W/m}^2$. Stir the MB solution at least every 20 min during the test to ensure a homogeneous concentration. Carry out stirring manually, with a glass stirrer, magnetic stirrer, or by purging with compressed air. During the entire measurement, measure and keep the temperature of the test solution at $(23 \pm 2) \text{ }^\circ\text{C}$ and record it. Temperature measurement and control is permitted inside, as well as near, the test cylinder.

Set the detection wavelength of the spectrophotometer at $\lambda = (664 \pm 5) \text{ nm}$. The measurement may either be performed online directly through the test solution (2.3) (see curve 2 in Figure 1) or by external measurements of measuring solutions (2.4) taken from the test solution and subsequently added back to the test solution before continuing the UV radiation. Measure the optical density of the test solution in regular intervals not exceeding 20 min. The total duration of the UV radiation shall be 3 h, but not longer than the time required for the total decolourization of the test solution.

Perform the blank (dark) experiment in an analogous fashion but without UV radiation (see curve 1 in Figure 1).

Record all measured values in a table linking optical density and time of measurement.

If the data evaluation (see Clause 11 and the example in Annex A) results in a mean photonic efficiency $\zeta_{\text{MB}} > 0,10 \%$, repeat the measurement at a UV-radiation intensity of $E = (2,5 \pm 0,13) \text{ W/m}^2$. If the subsequent data analysis yields a higher value for the mean photonic efficiency than that obtained at the higher UV-radiation intensity, for the test report, use the value determined at the UV-radiation intensity of $E = (2,5 \pm 0,13) \text{ W/m}^2$. This observation of the high mean photonic efficiency at a UV-radiation intensity of $E = (10 \pm 0,5) \text{ W/m}^2$ shall also be included in the test report.

11 Evaluation of results

11.1 General

For the quantitative data treatment, use only the linear part of the degradation curve, i.e. the values between t_3 and t_4 (see Figure 1). In the case of the devices shown in Figures B.1 and B.2, the degradation rate can alternatively be calculated from nine points, except for the starting point (0 min), by the minimum-mean-square method. Report all values rounded to three decimal places.

An example of an appropriate data treatment is given in Annex A.

11.2 Specific degradation rate, R

The specific degradation rate, R , is calculated using Equation (2):

$$R = \frac{\Delta A_{\lambda} V}{\Delta t \epsilon d A} \quad (2)$$

11.3 Photon UV-radiation intensity, E_P

The photon UV-radiation intensity, E_P , is calculated, based upon a constant UV-radiation intensity E , using Equation (3):

$$E_P = \frac{\lambda_{\max} E}{hc N_A} \times 3\,600 = \lambda_{\max} E \times 30\,074 \quad (3)$$

11.4 Average UV-radiation intensity, E_{av}

The average UV-radiation intensity, E_{av} , is calculated using Equation (4):

$$E_{av} = \frac{\int E dt}{t_m} \quad (4)$$

11.5 Average photon UV-radiation intensity, $E_{P,av}$

The average photon UV-radiation intensity, $E_{P,av}$, is calculated from the average UV-radiation intensity, E_{av} , using Equation (5):

$$E_{P,av} = \frac{\lambda_{\max} E_{av}}{hc N_A} \times 3\,600 = \lambda_{\max} E_{av} \times 30\,074 \quad (5)$$

11.6 Specific photoactivity, P_{MB}

The specific photoactivity, P_{MB} , is calculated using Equation (6):

$$P_{MB} = R_{irr} - R_{dark} \quad (6)$$

11.7 Photonic efficiency, ζ_{MB}

The photonic efficiency, ζ_{MB} , is calculated using Equation (7):

$$\zeta_{MB} = \frac{P_{MB}}{E_P} \times 100 \quad (7)$$

12 Precision

12.1 Repeatability

The absolute difference between two independent measurements carried out within a short time period, for the same sample in the same laboratory by the same operator using the same experimental and analytical measuring device, will not exceed the repeatability limit, r , in more than 5 % of cases.

Typical precision data for four different laboratories obtained in an inter-laboratory test are given in Annex C.

12.2 Reproducibility

The absolute difference between two individual measurements carried out using the same test method, for the same sample in different laboratories by different operators using different experimental and analytical measuring devices, will not exceed the reproducibility limit, R , in more than 5 % of cases.

Typical precision data obtained in an inter-laboratory test are given in Annex C.

13 Test report

The test report shall include the following information:

- a) a reference to this International Standard, i.e. determined in accordance with ISO 10678:2010;
- b) name of the testing laboratory;
- c) details concerning the sample (dimensions of the sample surface tested, composition, pre-treatment steps used) and concerning the measurement device [kind of measuring device (Figure B.1 or B.2), dimension, sample position, volume of test solution];
- d) temperature in the laboratory;
- e) UV-radiation light source used;
- f) manufacturer and type of UV radiometer;
- g) UV-radiation intensity, E , and type of UV radiation (continuous or periodical);
- h) specific photoactivity, P_{MB} , information on start and end of constancy;
- i) photonic efficiency, ζ_{MB} , information on start and end of constancy;
- j) if applicable, deviations from this International Standard;
- k) details of any operation not specified in this International Standard or in the International Standards to which reference is made, and any operations regarded as optional, as well as any incidents likely to have affected the results.

Annex A (informative)

Example of a data evaluation

The measurements were performed in a cylinder with a volume of $V=0,03$ L, fixed on an area of $A=10,75$ cm²; the UV-radiation wavelength was $\lambda=365$ nm and the measuring cell for the spectrophotometer had a length of $d=10$ mm. The time interval used for the data analysis starts at $t_m=0$ (equivalent to t_3 in Figure 1) and stops at the end of the linear regime with $t_m=80$ (t_4 in Figure 1). The specific degradation rates R_{irr} and R_{dark} , the specific photoactivity P_{MB} and the photonic efficiency ζ_{MB} were calculated using Equations (2), (6) and (7). The values are determined as the difference of subsequent values for t_m and A_λ . At a time $t_m > 80$ min, both the specific photoactivity P_{MB} and the photonic efficiency ζ_{MB} start decreasing steadily. Therefore, values at $t_m > 80$ min are not considered. The result is determined as the arithmetic mean of all values calculated for P_{MB} and ζ_{MB} during the time interval from $t_m=20$ min to $t_m=80$ min. The mean specific photoactivity is $P_{MB}=2,54 \times 10^{-5}$ mol/m²h and the mean photonic efficiency is $\zeta_{MB}=0,024$ % in the chosen example. The results for this example calculation are given in Table A.1.

Table A.1 — Evaluation of the data for a given example

t_m min	t_m h	$A_{\lambda,irr}$ 1	$A_{\lambda,dark}$ 1	E, E_{av} W/m ² $E_{av}:(4)^a$	$E_p, E_{p,av}$ mol/m ² h (3), (5) ^a	R_{irr} mol/m ² h (2) ^a	R_{dark} mol/m ² h (2) ^a	R_{MB} mol/m ² h (6) ^a	ζ_{MB} % (7) ^a
0	0,00	0,57	0,549	10	0,110				
20	0,33	0,545	0,546	10	0,110	$2,83 \times 10^{-5}$	$3,39 \times 10^{-6}$	$2,49 \times 10^{-5}$	0,023
40	0,67	0,512	0,54	10	0,110	$3,73 \times 10^{-5}$	$6,79 \times 10^{-6}$	$3,05 \times 10^{-5}$	0,028
60	1,00	0,49	0,538	10	0,110	$2,49 \times 10^{-5}$	$2,26 \times 10^{-6}$	$2,26 \times 10^{-5}$	0,021
80	1,33	0,461	0,53	10	0,110	$3,28 \times 10^{-5}$	$9,05 \times 10^{-6}$	$2,37 \times 10^{-5}$	0,022
100	1,67	0,45	0,52	10	0,110	$1,24 \times 10^{-5}$	$1,13 \times 10^{-5}$	$1,13 \times 10^{-6}$	0,001
120	2,00	0,426	0,517	10	0,110	$2,71 \times 10^{-5}$	$3,39 \times 10^{-6}$	$2,37 \times 10^{-5}$	0,022
140	2,33	0,406	0,511	10	0,110	$2,26 \times 10^{-5}$	$6,79 \times 10^{-6}$	$1,58 \times 10^{-5}$	0,014
160	2,67	0,385	0,507	10	0,110	$2,37 \times 10^{-5}$	$4,52 \times 10^{-6}$	$1,92 \times 10^{-5}$	0,018
180	3,00	0,365	0,5	10	0,110	$2,26 \times 10^{-5}$	$7,92 \times 10^{-6}$	$1,47 \times 10^{-5}$	0,013

^a Number of equation.

Annex B (informative)

Examples of suitable measuring devices

B.1 Schematic diagram of a measuring device using a test cylinder

Key

- 1 sample
- 2 testing area, point where light intensity is measured
- 3 testing cylinder
- 4 glass pane (5.3)
- 5 UV-radiation light source (5.4)

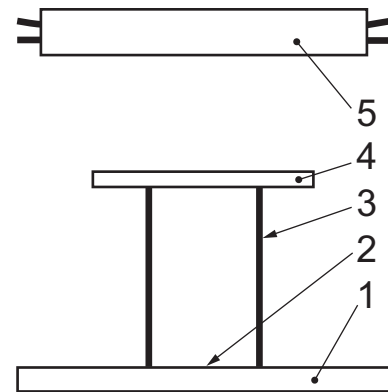

Figure B.1 — Schematic diagram of a measuring device with a test cylinder

B.2 Schematic diagram of a measuring device using a testing cell

Key

- 1 UV radiometer (5.5)
- 2 magnetic stirrer
- 3 sample
- 4 test solution
- 5 test cells
- 6 glass pane (5.3)
- 7 cover against UV-radiation
- 8 UV-radiation light source (5.4)
- 9 UV/vis-spectrophotometer (5.6)

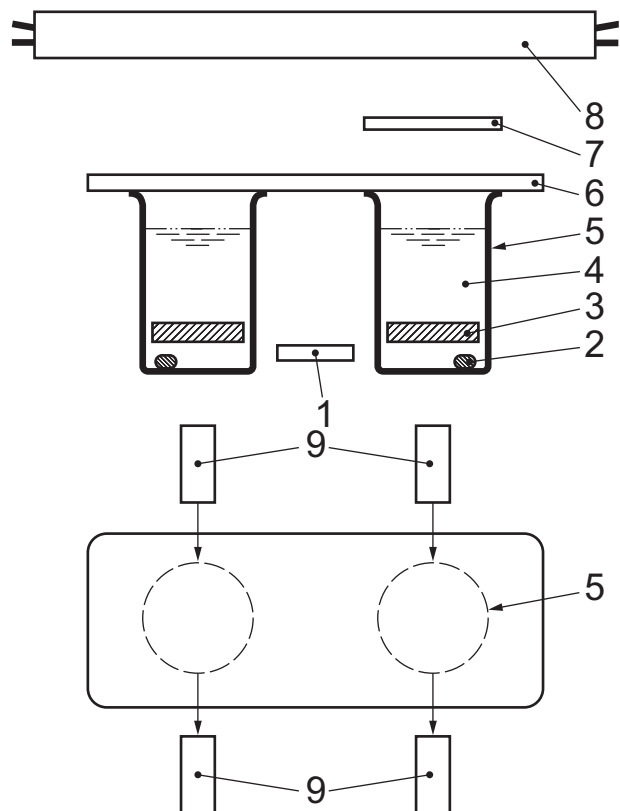

Figure B.2 — Schematic diagram of a measuring device with a testing cell

B.3 UV-radiation device and sensor

A suitable UV-radiation device for the irradiation of the sample in the UV-A region should have an emission in the wavelength range of 320 nm to 400 nm.

A suitable sensor for the measurement of the UV-radiation intensity in the UV-A region is a sensor with a calibration close to the emission spectrum of the UV-radiation device.

Annex C (informative)

Results of the inter-laboratory test

The results of the inter-laboratory test were obtained by four different German test laboratories in 2006. The evaluation of the results was performed in accordance with ISO 5725-2^[1]. The results are summarized in Table C.1.

Table C.1 — Results of inter-laboratory test

	Number of individual values	Mean value $\overline{P_{MB}}$ $\mu\text{mol}/(\text{m}^2\text{h})$	Standard deviation s $\mu\text{mol}/(\text{m}^2\text{h})$
Laboratory 1	7	26,9	1,32
Laboratory 2	6	15,7	2,6
Laboratory 3	4	14,9	1,48
Laboratory 4	4	20,8	1,54
Weighted mean value $\overline{\overline{P_{MB}}}$ of all laboratories in $\mu\text{mol}/(\text{m}^2\text{h})$	20,25		
Repeatability standard deviation, s_p , in $\mu\text{mol}/(\text{m}^2\text{h})$	1,85		
Repeatability limit, r ($r = 2,8 \times s_p$), in $\mu\text{mol}/(\text{m}^2\text{h})$	5,18		
Coefficient of variation of repeatability, in %	9,2		
Reproducibility standard deviation, s_R , in $\mu\text{mol}/(\text{m}^2\text{h})$	6,19		
Reproducibility limit, R ($R = 2,8 \times s_R$), in $\mu\text{mol}/(\text{m}^2\text{h})$	17,3		
Coefficient of variation of reproducibility, in %	30,6		

Bibliography

- [1] ISO 5725-2, *Accuracy (trueness and precision) of measurement methods and results — Part 2: Basic method for the determination of repeatability and reproducibility of a standard measurement method*
- [2] Scott Pahl, Oregon Medical Laser Center, <http://omlc.ogi.edu/spectra/mb>

British Standards Institution (BSI)

BSI is the independent national body responsible for preparing British Standards and other standards-related publications, information and services.

It presents the UK view on standards in Europe and at the international level.

It is incorporated by Royal Charter.

Revisions

British Standards are updated by amendment or revision. Users of British Standards should make sure that they possess the latest amendments or editions.

It is the constant aim of BSI to improve the quality of our products and services. We would be grateful if anyone finding an inaccuracy or ambiguity while using this British Standard would inform the Secretary of the technical committee responsible, the identity of which can be found on the inside front cover.

Tel: +44 (0)20 8996 9001 Fax: +44 (0)20 8996 7001

BSI offers Members an individual updating service called PLUS which ensures that subscribers automatically receive the latest editions of standards.

Tel: +44 (0)20 8996 7669 Fax: +44 (0)20 8996 7001

Email: plus@bsigroup.com

Buying standards

You may buy PDF and hard copy versions of standards directly using a credit card from the BSI Shop on the website www.bsigroup.com/shop. In addition all orders for BSI, international and foreign standards publications can be addressed to BSI Customer Services.

Tel: +44 (0)20 8996 9001 Fax: +44 (0)20 8996 7001

Email: orders@bsigroup.com

In response to orders for international standards, it is BSI policy to supply the BSI implementation of those that have been published as British Standards, unless otherwise requested.

Information on standards

BSI provides a wide range of information on national, European and international standards through its Knowledge Centre.

Tel: +44 (0)20 8996 7004 Fax: +44 (0)20 8996 7005

Email: knowledgecentre@bsigroup.com

Various BSI electronic information services are also available which give details on all its products and services.

Tel: +44 (0)20 8996 7111 Fax: +44 (0)20 8996 7048

Email: info@bsigroup.com

BSI Subscribing Members are kept up to date with standards developments and receive substantial discounts on the purchase price of standards. For details of these and other benefits contact Membership Administration.

Tel: +44 (0)20 8996 7002 Fax: +44 (0)20 8996 7001

Email: membership@bsigroup.com

Information regarding online access to British Standards via British Standards Online can be found at www.bsigroup.com/BSOL

Further information about BSI is available on the BSI website at www.bsigroup.com/standards

Copyright

Copyright subsists in all BSI publications. BSI also holds the copyright, in the UK, of the publications of the international standardization bodies. Except as permitted under the Copyright, Designs and Patents Act 1988 no extract may be reproduced, stored in a retrieval system or transmitted in any form or by any means – electronic, photocopying, recording or otherwise – without prior written permission from BSI. This does not preclude the free use, in the course of implementing the standard of necessary details such as symbols, and size, type or grade designations. If these details are to be used for any other purpose than implementation then the prior written permission of BSI must be obtained. Details and advice can be obtained from the Copyright & Licensing Manager.

Tel: +44 (0)20 8996 7070

Email: copyright@bsigroup.com

BSI Group Headquarters

389 Chiswick High Road London W4 4AL UK

Tel +44 (0)20 8996 9001

Fax +44 (0)20 8996 7001

www.bsigroup.com/standards