

BS ISO 10649-1:2013



BSI Standards Publication

# Cutter arbors with parallel key and tenon drive

Part 1: General dimensions

**bsi.**

...making excellence a habit.™

**National foreword**

This British Standard is the UK implementation of ISO 10649-1:2013. It supersedes BS ISO 10649-1:2010 which is withdrawn.

The UK participation in its preparation was entrusted to Technical Committee MTE/18, Tools tips and inserts for cutting applications.

A list of organizations represented on this committee can be obtained on request to its secretary.

This publication does not purport to include all the necessary provisions of a contract. Users are responsible for its correct application.

© The British Standards Institution 2013. Published by BSI Standards Limited 2013

ISBN 978 0 580 77003 6

ICS 25.060.20

**Compliance with a British Standard cannot confer immunity from legal obligations.**

This British Standard was published under the authority of the Standards Policy and Strategy Committee on 30 November 2013.

**Amendments issued since publication**

Date	Text affected
------	---------------

---

INTERNATIONAL  
STANDARD

BS ISO 10649-1:2013

**ISO**  
**10649-1**

Second edition  
2013-10-15

---

---

**Cutter arbors with parallel key and  
tenon drive —**

Part 1:  
**General dimensions**

*Mandrins porte-fraise à entraînement par clavette et tenon —  
Partie 1: Dimensions générales*



Reference number  
ISO 10649-1:2013(E)

© ISO 2013



**COPYRIGHT PROTECTED DOCUMENT**

© ISO 2013

All rights reserved. Unless otherwise specified, no part of this publication may be reproduced or utilized otherwise in any form or by any means, electronic or mechanical, including photocopying, or posting on the internet or an intranet, without prior written permission. Permission can be requested from either ISO at the address below or ISO's member body in the country of the requester.

ISO copyright office  
Case postale 56 • CH-1211 Geneva 20  
Tel. + 41 22 749 01 11  
Fax + 41 22 749 09 47  
E-mail [copyright@iso.org](mailto:copyright@iso.org)  
Web [www.iso.org](http://www.iso.org)

Published in Switzerland

# Contents

	Page
<b>Foreword</b> .....	<b>iv</b>
<b>Introduction</b> .....	<b>v</b>
<b>1 Scope</b> .....	<b>1</b>
<b>2 Normative references</b> .....	<b>1</b>
<b>3 Dimensions</b> .....	<b>1</b>
3.1 General .....	1
3.2 Dimensions of tool interface for arbors with parallel key and tenon drive .....	1
<b>Annex A (informative) Relationship between the symbols of this part of ISO 10649 and the ISO 13399 series</b> .....	<b>4</b>
<b>Bibliography</b> .....	<b>5</b>

## Foreword

ISO (the International Organization for Standardization) is a worldwide federation of national standards bodies (ISO member bodies). The work of preparing International Standards is normally carried out through ISO technical committees. Each member body interested in a subject for which a technical committee has been established has the right to be represented on that committee. International organizations, governmental and non-governmental, in liaison with ISO, also take part in the work. ISO collaborates closely with the International Electrotechnical Commission (IEC) on all matters of electrotechnical standardization.

The procedures used to develop this document and those intended for its further maintenance are described in the ISO/IEC Directives, Part 1. In particular the different approval criteria needed for the different types of ISO documents should be noted. This document was drafted in accordance with the editorial rules of the ISO/IEC Directives, Part 2. [www.iso.org/directives](http://www.iso.org/directives)

Attention is drawn to the possibility that some of the elements of this document may be the subject of patent rights. ISO shall not be held responsible for identifying any or all such patent rights. Details of any patent rights identified during the development of the document will be in the Introduction and/or on the ISO list of patent declarations received. [www.iso.org/patents](http://www.iso.org/patents)

Any trade name used in this document is information given for the convenience of users and does not constitute an endorsement.

The committee responsible for this document is ISO/TC 29, *Small tools*, Subcommittee SC 2, *High speed steel cutting tools and their attachments*.

This second edition cancels and replaces the first edition (ISO 10649-1:2010), of which it constitutes a minor revision with the following changes:

- addition of [Annex A](#), which gives the relationship between the symbols of this part of ISO 10649 and the symbols according to the ISO 13399 series.

ISO 10649 consists of the following parts, under the general title *Cutter arbors with parallel key and tenon drive*:

- *Part 1: General dimensions*
- *Part 2: Dimensions and designation of tool holders with taper interface with flange contact surface*
- *Part 3: Dimensions and designation of tool holders with 7/24 taper for automatic tool changer*
- *Part 4: Dimensions and designation of tool holders with 7/24 taper without automatic tool changer*
- *Part 5: Dimensions and designation of tool holders with polygonal taper interface with flange contact surface*
- *Part 6: Dimensions and designation of tool holders with modular taper interface with ball track system*

## Introduction

The aim of ISO 10649 (all parts) is to specify the main dimensions for tool holders for this type of interface, and prevent the risk of collision when exchanging the assembled tool within the machine tools.





# Cutter arbors with parallel key and tenon drive —

## Part 1: General dimensions

### 1 Scope

This part of ISO 10649 specifies the dimensions of tool interface for cutter arbors with parallel key and tenon drive.

### 2 Normative references

The following documents, in whole or in part, are normatively referenced in this document and are indispensable for its application. For dated references, only the edition cited applies. For undated references, the latest edition of the referenced document (including any amendments) applies.

ISO 2768-1, *General tolerances — Part 1: Tolerances for linear and angular dimensions without individual tolerance indications*

ISO 2768-2, *General tolerances — Part 2: Geometrical tolerances for features without individual tolerance indications*

ISO 2780, *Milling cutters with tenon drive — Interchangeability dimensions for cutter arbors — Metric series*

ISO 10643, *Dimensions of accessories for cutter arbors with parallel key and tenon drive*

### 3 Dimensions

#### 3.1 General

All dimensions and tolerances are given in millimetres. Tolerances not specified shall be of tolerance class “m” in accordance with ISO 2768-1 and of class “K” in accordance with ISO 2768-2.

The figures are schematic and are not intended to specify a given design; only the given dimension shall be met.

The interchangeability dimensions of the milling cutter bearing on the cutter arbors shall be in accordance with ISO 2780.

#### 3.2 Dimensions of tool interface for arbors with parallel key and tenon drive

The dimensions of tool interface for arbors with parallel key and tenon drive shall be in accordance with the dimensions shown in [Figure 1](#) and given in [Table 1](#).

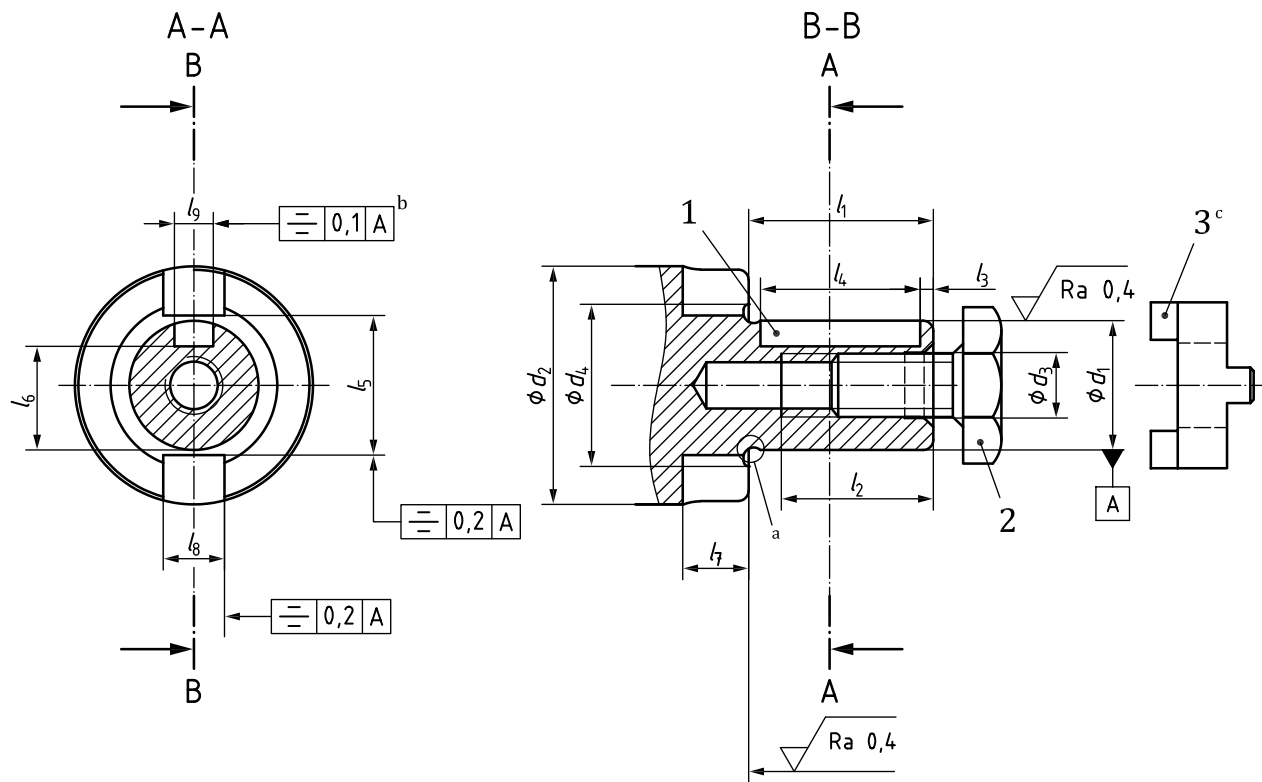

**Key**

- 1 parallel key in accordance with ISO 10643
- 2 cutter retaining screw in accordance with ISO 10643
- 3 clutch drive ring in accordance with ISO 10643
- a Under cut at the manufacturer's discretion.
- b Positioning against the position of the cutting edge for right-hand tools with single cutting edge of the interface.
- c The clutch drive ring may be fitted on spigot diameter  $d_1$ .

**Figure 1 — Dimensions of tool interface for arbors with parallel key and tenon drive**

**Table 1 — Dimensions**

$d_1$ h6	$d_2^a$	$d_3$	$d_4$ max.	$l_1$	$l_2$ min.	$l_3$	$l_4$ +0,1 +0,3	$l_5$	$l_6$ - tol.	$l_7$ min.	$l_8^b$ F9	$l_9$ P9
<b>16</b>	32	M8	19	27	20	2	20	17	13,2 0 -0,1	5,5	8	4
<b>22</b>	40	M10	25	31	22	2	25	23	17,6 0 -0,2	6	10	6
<b>27</b>	48	M12	30	33	26	3	25	28	22 0 -0,2	7	12	7
<b>32</b>	58	M16	36	38	30	3	28	33	27 0 -0,2	7,5	14	8

<sup>a</sup> From ISO 2780.  
<sup>b</sup> Full with depth  $l_7$ .

**Table 1 (continued)**

$d_1$ h6	$d_2^a$	$d_3$	$d_4$ max.	$l_1$	$l_2$ min.	$l_3$	$l_4$ +0,1 +0,3	$l_5$	$l_6$ - tol.		$l_7$ min.	$l_8^b$ F9	$l_9$ P9
<b>40</b>	70	M20	44	41	34	3	32	41	34,5	$\begin{matrix} 0 \\ -0,2 \end{matrix}$	8,5	16	10
<b>50</b>	90	M24	54	46	40	3	36	51	44,5	$\begin{matrix} 0 \\ -0,2 \end{matrix}$	9,5	18	12
a From ISO 2780. b Full with depth $l_7$ .													

## **Annex A** (informative)

### **Relationship between the symbols of this part of ISO 10649 and the ISO 13399 series**

As this part of ISO 10649 does not define an entire product, the relationship between the symbols of this part of ISO 10649 and symbols according to the ISO 13399 series are not given. They are given in the entire product standards ISO 10649-2, ISO 10649-3, ISO 10649-4, ISO 10649-5 and ISO 10649-6, and future parts to be developed.

## Bibliography

- [1] ISO 13399 (all parts), *Cutting tool data representation and exchange*





# British Standards Institution (BSI)

BSI is the national body responsible for preparing British Standards and other standards-related publications, information and services.

BSI is incorporated by Royal Charter. British Standards and other standardization products are published by BSI Standards Limited.

## About us

We bring together business, industry, government, consumers, innovators and others to shape their combined experience and expertise into standards-based solutions.

The knowledge embodied in our standards has been carefully assembled in a dependable format and refined through our open consultation process. Organizations of all sizes and across all sectors choose standards to help them achieve their goals.

## Information on standards

We can provide you with the knowledge that your organization needs to succeed. Find out more about British Standards by visiting our website at [bsigroup.com/standards](http://bsigroup.com/standards) or contacting our Customer Services team or Knowledge Centre.

## Buying standards

You can buy and download PDF versions of BSI publications, including British and adopted European and international standards, through our website at [bsigroup.com/shop](http://bsigroup.com/shop), where hard copies can also be purchased.

If you need international and foreign standards from other Standards Development Organizations, hard copies can be ordered from our Customer Services team.

## Subscriptions

Our range of subscription services are designed to make using standards easier for you. For further information on our subscription products go to [bsigroup.com/subscriptions](http://bsigroup.com/subscriptions).

With **British Standards Online (BSOL)** you'll have instant access to over 55,000 British and adopted European and international standards from your desktop. It's available 24/7 and is refreshed daily so you'll always be up to date.

You can keep in touch with standards developments and receive substantial discounts on the purchase price of standards, both in single copy and subscription format, by becoming a **BSI Subscribing Member**.

**PLUS** is an updating service exclusive to BSI Subscribing Members. You will automatically receive the latest hard copy of your standards when they're revised or replaced.

To find out more about becoming a BSI Subscribing Member and the benefits of membership, please visit [bsigroup.com/shop](http://bsigroup.com/shop).

With a **Multi-User Network Licence (MUNL)** you are able to host standards publications on your intranet. Licences can cover as few or as many users as you wish. With updates supplied as soon as they're available, you can be sure your documentation is current. For further information, email [bsmusales@bsigroup.com](mailto:bsmusales@bsigroup.com).

## BSI Group Headquarters

389 Chiswick High Road London W4 4AL UK

## Revisions

Our British Standards and other publications are updated by amendment or revision.

We continually improve the quality of our products and services to benefit your business. If you find an inaccuracy or ambiguity within a British Standard or other BSI publication please inform the Knowledge Centre.

## Copyright

All the data, software and documentation set out in all British Standards and other BSI publications are the property of and copyrighted by BSI, or some person or entity that owns copyright in the information used (such as the international standardization bodies) and has formally licensed such information to BSI for commercial publication and use. Except as permitted under the Copyright, Designs and Patents Act 1988 no extract may be reproduced, stored in a retrieval system or transmitted in any form or by any means – electronic, photocopying, recording or otherwise – without prior written permission from BSI. Details and advice can be obtained from the Copyright & Licensing Department.

## Useful Contacts:

### Customer Services

**Tel:** +44 845 086 9001

**Email (orders):** [orders@bsigroup.com](mailto:orders@bsigroup.com)

**Email (enquiries):** [cservices@bsigroup.com](mailto:cservices@bsigroup.com)

### Subscriptions

**Tel:** +44 845 086 9001

**Email:** [subscriptions@bsigroup.com](mailto:subscriptions@bsigroup.com)

### Knowledge Centre

**Tel:** +44 20 8996 7004

**Email:** [knowledgecentre@bsigroup.com](mailto:knowledgecentre@bsigroup.com)

### Copyright & Licensing

**Tel:** +44 20 8996 7070

**Email:** [copyright@bsigroup.com](mailto:copyright@bsigroup.com)



...making excellence a habit.™