

**BS ISO 10631:2013**



**BSI Standards Publication**

# **Metallic butterfly valves for general purposes**

**bsi.**

...making excellence a habit.™

**National foreword**

This British Standard is the UK implementation of ISO 10631:2013.

The UK participation in its preparation was entrusted to Technical Committee PSE/18/3, Industrial valves, steam traps, actuators and safety devices against excessive pressure - Part turn valves (Ball, plug and butterfly).

A list of organizations represented on this committee can be obtained on request to its secretary.

This publication does not purport to include all the necessary provisions of a contract. Users are responsible for its correct application.

© The British Standards Institution 2013. Published by BSI Standards Limited 2013

ISBN 978 0 580 73191 4

ICS 23.060.99

**Compliance with a British Standard cannot confer immunity from legal obligations.**

This British Standard was published under the authority of the Standards Policy and Strategy Committee on 30 September 2013.

**Amendments issued since publication**

Date	Text affected
------	---------------

---

INTERNATIONAL  
STANDARD

BS ISO 10631:2013

**ISO**  
**10631**

Second edition  
2013-09-01

---

---

**Metallic butterfly valves for general  
purposes**

*Robinets métalliques à papillon d'usage général*



Reference number  
ISO 10631:2013(E)

© ISO 2013



**COPYRIGHT PROTECTED DOCUMENT**

© ISO 2013

All rights reserved. Unless otherwise specified, no part of this publication may be reproduced or utilized otherwise in any form or by any means, electronic or mechanical, including photocopying, or posting on the internet or an intranet, without prior written permission. Permission can be requested from either ISO at the address below or ISO's member body in the country of the requester.

ISO copyright office  
Case postale 56 • CH-1211 Geneva 20  
Tel. + 41 22 749 01 11  
Fax + 41 22 749 09 47  
E-mail [copyright@iso.org](mailto:copyright@iso.org)  
Web [www.iso.org](http://www.iso.org)

Published in Switzerland

# Contents

Page

<b>Foreword</b> .....	<b>iv</b>
<b>1 Scope</b> .....	<b>1</b>
<b>2 Normative references</b> .....	<b>1</b>
<b>3 Terms and definitions</b> .....	<b>2</b>
<b>4 Pressure/temperature ratings</b> .....	<b>4</b>
<b>5 Design</b> .....	<b>4</b>
5.1 Wall thickness.....	4
5.2 Construction examples.....	5
5.3 End connections.....	5
5.4 Shaft.....	7
5.5 Operation.....	7
5.6 Force or torque to be applied to manually actuated valves.....	8
5.7 Dimensions and tolerances of body ends.....	10
<b>6 Materials</b> .....	<b>11</b>
6.1 Body.....	11
6.2 Disc.....	11
6.3 Shaft.....	12
6.4 Seating.....	12
<b>7 Suitability of use</b> .....	<b>12</b>
7.1 Allowable leakage rate.....	12
7.2 Flow velocity.....	12
<b>8 Marking</b> .....	<b>12</b>
<b>9 Testing</b> .....	<b>13</b>
<b>10 Inspection and preparation for despatch</b> .....	<b>13</b>
<b>11 Example of data sheet</b> .....	<b>13</b>
<b>Annex A (informative) Example of data sheet</b> .....	<b>14</b>
<b>Bibliography</b> .....	<b>15</b>

## Foreword

ISO (the International Organization for Standardization) is a worldwide federation of national standards bodies (ISO member bodies). The work of preparing International Standards is normally carried out through ISO technical committees. Each member body interested in a subject for which a technical committee has been established has the right to be represented on that committee. International organizations, governmental and non-governmental, in liaison with ISO, also take part in the work. ISO collaborates closely with the International Electrotechnical Commission (IEC) on all matters of electrotechnical standardization.

The procedures used to develop this document and those intended for its further maintenance are described in the ISO/IEC Directives, Part 1. In particular the different approval criteria needed for the different types of ISO documents should be noted. This document was drafted in accordance with the editorial rules of the ISO/IEC Directives, Part 2. [www.iso.org/directives](http://www.iso.org/directives)

Attention is drawn to the possibility that some of the elements of this document may be the subject of patent rights. ISO shall not be held responsible for identifying any or all such patent rights. Details of any patent rights identified during the development of the document will be in the Introduction and/or on the ISO list of patent declarations received. [www.iso.org/patents](http://www.iso.org/patents)

Any trade name used in this document is information given for the convenience of users and does not constitute an endorsement.

The committee responsible for this document is ISO/TC 153, *Valves*, Subcommittee SC 1, *Design, manufacture, marking and testing*.

This second edition cancels and replaces the first edition (ISO 10631:1994), which has been technically revised.

# Metallic butterfly valves for general purposes

## 1 Scope

This International Standard specifies requirements for design, materials (e.g. steel, cast iron, ductile iron, copper alloy), pressure/temperature ratings and testing for butterfly valves having metallic bodies for use in general purpose flanged or butt welding piping systems.

This International Standard covers butterfly valves of the following nominal sizes, DN and NPS:

- DN 40; 50; 65; 80; 100; 125; 150; 200; 250; 300; 350; 400; 450; 500 (550); 600 (650); 700; 750; 800; 900; 1 000; 1 200; 1 400; 1 600; 1 800; 2 000; 2 200; 2 400.
- NPS 1 1/2; 2; 2 1/2; 3; 4; 5; 6; 8; 10; 12; 14; 16; 18; 20; (22); 24; (26); 28; 30; 32; 36; 40; 48; 56; 64; 72; 80; 88; 96.

This International Standard is applicable to butterfly valves of the following pressure designations, PN and Class:

- PN 2,5; PN 6; PN 10; PN 16; PN 25; PN 40;
- Class 125; 150; 300.

## 2 Normative references

The following documents, in whole or in part, are normatively referenced in this document and are indispensable for its application. For dated references, only the edition cited applies. For undated references, the latest edition of the referenced document (including any amendments) applies.

ISO 185, *Grey cast irons — Classification*

ISO 1083, *Spheroidal graphite cast irons - Classification*

ISO 3755, *Cast carbon steels for general engineering purposes*

ISO 4991, *Steel castings for pressure purposes*

ISO 5208:2008, *Industrial valves — Pressure testing of metallic valves*

ISO 5209:1977, *General purpose industrial valves — Marking*

ISO 5211, *Industrial valves — Part-turn actuator attachments*

ISO 5752, *Metal valves for use in flanged pipe systems — Face-to-face and centre-to-face dimensions*

ISO 5922, *Malleable cast iron*

ISO 7005-3, *Metallic flanges — Part 3: Copper alloy and composite flanges*

ISO 9327-1, *Steel forgings and rolled or forged bars for pressure purposes — Technical delivery conditions — Part 1: General requirements*

ISO 9327-2, *Steel forgings and rolled or forged bars for pressure purposes — Technical delivery conditions — Part 2: Non-alloy and alloy (Mo, Cr and CrMo) steels with specified elevated temperature properties*

ISO 9327-3, *Steel forgings and rolled or forged bars for pressure purposes — Technical delivery conditions — Part 3: Nickel steels with specified low temperature properties*

ISO 9327-4, *Steel forgings and rolled or forged bars for pressure purposes — Technical delivery conditions — Part 4: Weldable fine grain steels with high proof strength*

ISO 9327-5, *Steel forgings and rolled or forged bars for pressure purposes — Technical delivery conditions — Part 5: Stainless steels*

ISO 9328-1, *Steel flat products for pressure purposes — Technical delivery conditions — Part 1: General requirements*

ISO 9328-2, *Steel flat products for pressure purposes — Technical delivery conditions — Part 2: Non-alloy and alloy steels with specified elevated temperature properties*

ISO 9328-3, *Steel flat products for pressure purposes — Technical delivery conditions — Part 3: Weldable fine grain steels, normalized*

ISO 9328-4, *Steel flat products for pressure purposes — Technical delivery conditions — Part 4: Nickel-alloy steels with specified low temperature properties*

ISO 9328-5, *Steel flat products for pressure purposes — Technical delivery conditions — Part 5: Weldable fine grain steels, thermomechanically rolled*

EN 1092-1:2007, *Flanges and their joints — Circular flanges for pipes, valves, fittings and accessories PN designated — Part 1: Steel flanges*

EN 1092-2, *Flanges and their joints — Circular flanges for pipes, valves, fittings and accessories, PN designated — Part 2: Cast iron flanges*

EN 1092-3, *Flanges and their joints — Circular flanges for pipes, valves, fittings and accessories, PN designated — Part 3: Copper alloy flanges*

EN 12516-1, *Industrial valves — Shell design strength — Part 1: Tabulation method for steel valve shells*

EN 12516-2, *Industrial valves — Shell design strength — Part 2: Calculation method for steel valve shells*

EN 12516-4, *Industrial valves — Shell design strength — Part 4: Calculation method for valve shells manufactured in metallic materials other than steel*

ASME B1.1, *Unified Inch Screw Threads, UN and UNR Thread Form*

ASME B16.1, *Gray Iron Pipe Flanges and Flanged Fittings: Classes 25, 125, and 250*

ASME B16.5, *Pipe Flanges and Flanged Fittings: NPS 1/2 through NPS 24 Metric/Inch Standard*

ASME B16.24, *Cast Copper Alloy Pipe Flanges and Flanged Fittings: Classes 150, 300, 600, 900, 1500 and 2500*

ASME B16.25, *Buttwelding Ends*

ASME B16.34, *Valves Flanged, Threaded and Welding End*

ASME B16.42, *Ductile Iron Pipe Flanges and Flanged Fittings: Classes 150 and 300*

ASME B16.47, *Large Diameter Steel Flanges: NPS 26 through NPS 60 Metric/Inch Standard*

### **3 Terms and definitions**

For the purposes of this document, the following terms and definitions apply.



**3.1**  
**nominal size**  
**DN**

alphanumeric designation of size for components of a pipework system, which is used for reference purposes, comprising the letters DN followed by a dimensionless whole number which is indirectly related to the physical size, in millimetres, of the bore or outside diameter of the end connections

[SOURCE: ISO 6708:1995, definition 2.1]

**3.2**  
**nominal pressure**  
**PN**

numerical designation relating to pressure that is a convenient rounded number for reference purposes, and which comprises the letters PN followed by the appropriate reference number

Note 1 to entry: It is intended that all equipment of the same nominal size (DN) designated by the same PN number have compatible mating dimensions.

Note 2 to entry: The maximum allowable pressure depends on materials, design, and working temperature, and is to be selected from the tables of pressure/temperature ratings given in the appropriate standards.

[SOURCE: ISO 7268:1983, Clause 2, modified — The definition and Notes 1 and 2 have been slightly modified.]

**3.3**  
**NPS**

alphanumeric designation of size for components of a pipework system, which is used for reference purposes, and which comprises the letters NPS followed by a dimensionless number indirectly related to the physical size of the bore or outside diameter of the end connections

Note 1 to entry: The number following the letters NPS does not represent a measurable value and is not intended to be used for calculation purposes except where specified in the relevant standard.

**3.4**  
**Class**

alphanumeric designation used for reference purposes related to a combination of mechanical and dimensional characteristics of a component of a pipework system, which comprises the word “Class” followed by a dimensionless whole number

Note 1 to entry: The number following the word “Class” does not represent a measurable value and is not intended to be used for calculation purposes except where specified in the relevant standard.

**3.5**  
**face-to-face dimension**

distance between the body ends of the installed equipment in accordance with ISO 5752

**3.6**  
**differential pressure**

$\Delta p$

limiting pressure difference across the upstream and downstream sides of the closure element seals when the valve is in the closed position

Note 1 to entry: Differential pressure is expressed in bar.<sup>1)</sup>

**3.7**  
**cold working pressure**  
**CWP**

maximum fluid pressure assigned to a valve for operation at a fluid temperature between - 20 °C and 38 °C

---

1) 1 bar = 0,1 MPa = 10<sup>5</sup> Pa; 1 MPa = 1 N/mm<sup>2</sup>.

## 4 Pressure/temperature ratings

The pressure/temperature ratings of the valve shall meet the specification given in the appropriate pressure/temperature tables of the standards listed in [Table 1](#).

**Table 1**

Body material	PN-designated valve	Class-designated valve
Steel	EN 12516-1	ASME B16.34
Cast iron	EN 1092-2	ASME B16.1
Ductile iron		ASME B16.42
Copper alloy	EN 1092-3	ASME B16.24

The complete assembly shall comply with differential pressure  $\Delta p$ /temperature ratings. The maximum allowable temperature and/or the design differential pressure may be limited by restrictions in the pressure/temperature ratings of materials used for certain components.

Restrictions shall be marked on the valve by the manufacturer (see [Clause 8](#)).

For temperatures below the lowest temperature listed in the pressure/temperature tables, the working pressure shall be no greater than the pressure for the lowest listed temperature. The use of valves at lower temperatures is the responsibility of the user. Consideration should be given to the loss of ductility and impact strength of materials at low temperature.

## 5 Design

### 5.1 Wall thickness

The minimum wall thickness shall be determined using the standards indicated in [Table 2](#).

For pressure-temperature ratings of the valve bodies outside the size ranges of the referenced standards of [Table 2](#), design and calculations for pressure-containing elements shall be in accordance with an internationally recognised design code or standards with consideration of pipe loads, operating forces, etc. The choice of standard shall be by agreement.

NOTE Examples of internationally recognised design codes or standards are ASME Section VIII, Division 1, or Division 2, and EN 13445-3.

**Table 2**

Body material	PN-designated valve	Class-designated valve
Steel	EN 12516-1	ASME B16.34
	EN 12516-2	
Cast iron	EN 12516-4	ASME B16.1
Ductile iron		ASME B16.42
Copper alloy		ASME B16.24

## 5.2 Construction examples

The valve shall be of either concentric disc design [see [Figure 1 a\)](#)] or eccentric disc design [see [Figure 1 b\)](#)]. The offset may be single, double or triple.

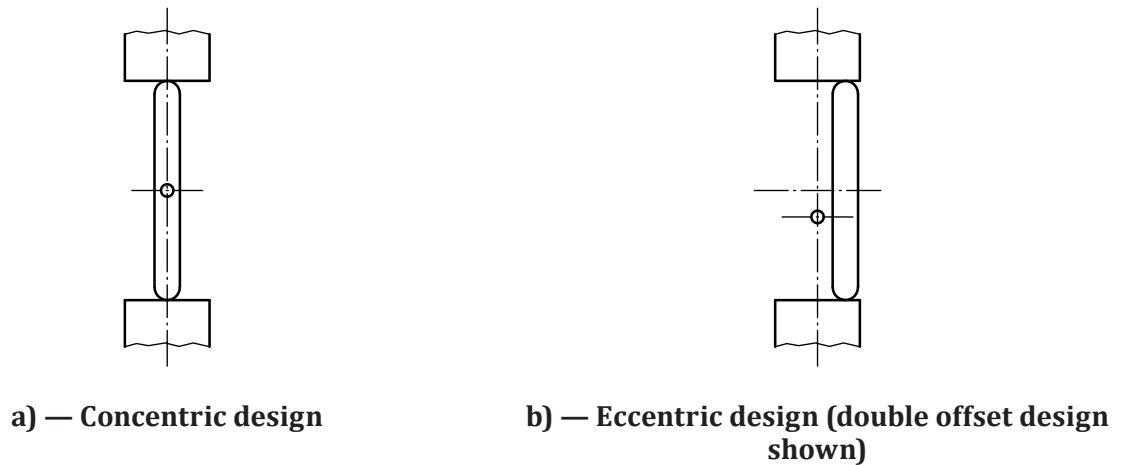

Figure 1 — Construction illustrations

## 5.3 End connections

### 5.3.1 Double-flanged valves

End connections of double-flanged valves shall be in accordance with [5.7.2.1](#). See [Figure 2](#).

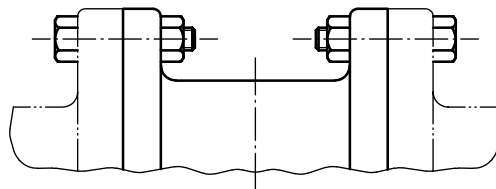

Figure 2 — End connections of double-flanged valves

### 5.3.2 Wafer-type valves

#### 5.3.2.1 General

The PN-designated valves are for installation between pipe flanges that are in accordance with EN 1092-1, EN 1092-2 and EN 1092-3.

The Class-designated valves are for installation between pipe flanges that are in accordance with ASME B16.5 for NPS ≤ 24 or ASME B16.47 for NPS > 24.

Where through bolting is used with the result that the valve shaft holes are too close to the bolt holes, threaded bolt holes may be substituted.

In case of valve size outside the scope of EN 1092, ASME B16.5 or ASME B16.47, another flange standard may be used by agreement between the manufacturer and the purchaser. The wall thickness is to be calculated by linear interpolation from standards specified in [Table 2](#).

5.3.2.2 Wafer valve bodies with or without lugs

Configurations of valves covered by this subclause are illustrated in [Figure 3](#).

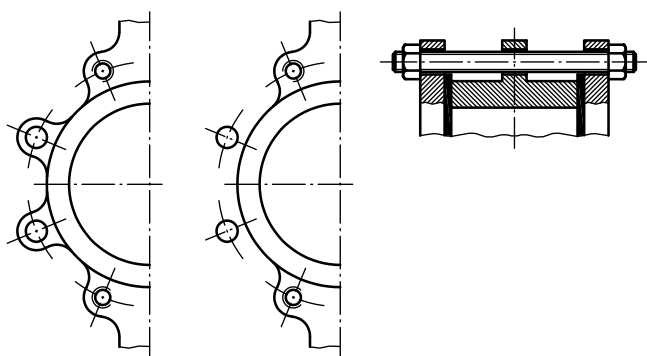

a) Valve with central lugs

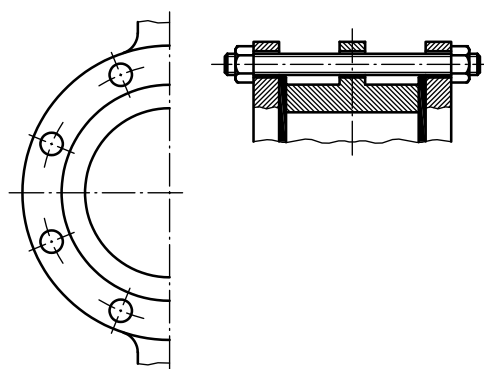

b) Central single-flange valve

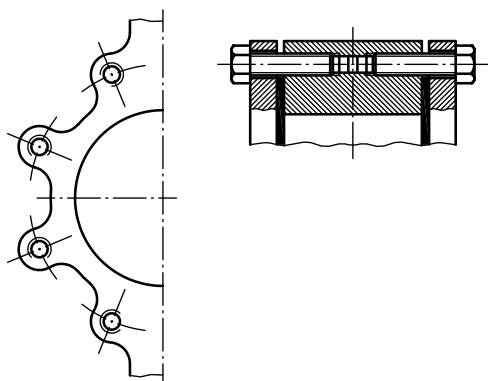

c) Valve with lugs with internally threaded holes

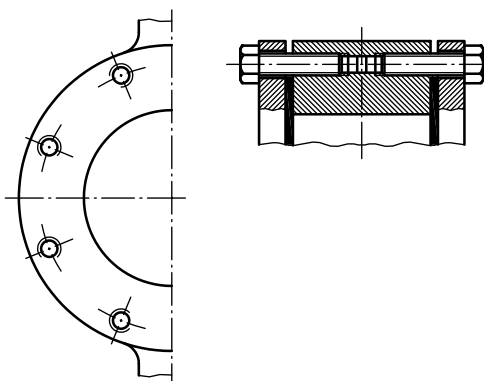

d) Single-flange valve with internally threaded holes

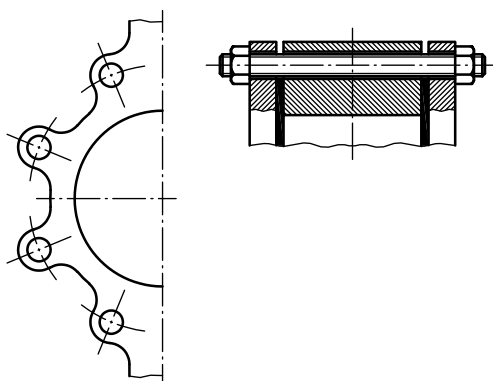

e) Valve with lugs with drilled holes

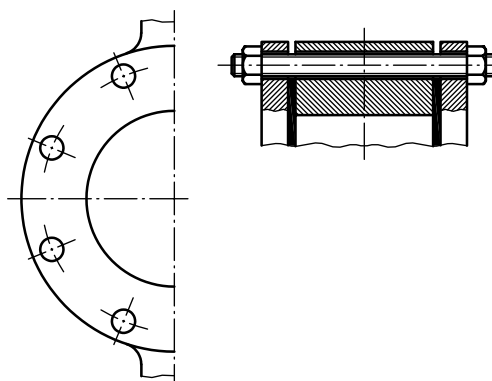

f) Single-flange valve with drilled holes

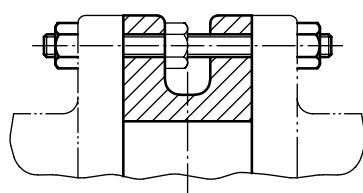

g) Valve with U-section

**Figure 3 — Wafer valve bodies bolting configurations**

### 5.3.2.3 Flangeless valves

Configurations of flangeless valves covered by this subclause are illustrated in [Figure 4](#).

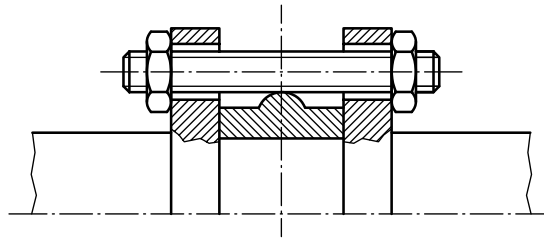
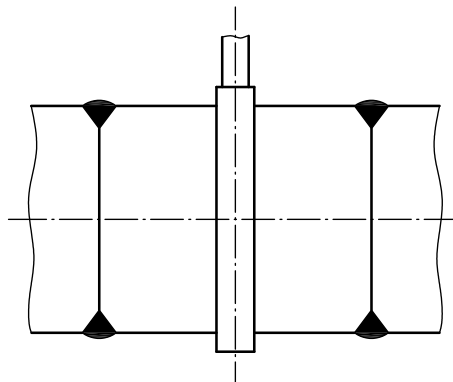

**Figure 4 — Typical flangeless valves**

The external diameter of a wafer-type valve body shall be such that the valve body is made to align with the flange bolting and the gasket surfaces.

### 5.3.3 Butt-welded ends

Configurations of butt-welded ends covered by this subclause are illustrated in [Figure 5](#).



**Figure 5 — Butt-welded ends**

NOTE Weld ends are limited to steel valve bodies.

## 5.4 Shaft

If removal of external parts from the valve becomes necessary while the valve is under pressure,

- the shaft shall not be ejected out of the valve, and
- the shaft tightness to the atmosphere shall remain.

NOTE External parts are parts which are not included in the bare shaft valve (bracket, lever, actuator, etc.).

## 5.5 Operation

### 5.5.1 Direction of rotation

Unless otherwise specified in the synopsis data sheet, the valve shall be closed by operating the handwheel, lever or T-wrench in the clockwise direction when facing those devices.

## 5.5.2 Actuating devices

### 5.5.2.1 General

Unless otherwise agreed between the manufacturer and the purchaser, the actuating device shall be capable of functioning between the fully open and fully closed positions.

### 5.5.2.2 Direct actuation

#### 5.5.2.2.1 Direct manual actuation

Direct manual actuation may be lever, handwheel or T-wrench.

Where a lever is used, the valve shall be open when the lever is parallel to the pipe.

When intermediate position is specified, means of securing the valve disc in intermediate positions shall be provided.

#### 5.5.2.2.2 Direct actuation by power actuator

When direct actuation is pneumatic, hydraulic or electric, the design of the valve shall be such that either with or without an intermediate part, mounting of the part-turn actuator with a plate complying with ISO 5211 shall be possible.

### 5.5.2.3 Gear actuation

The manual gear actuator shall be of self-locking movement design (in any position) and shall be provided with stops in the two extreme travel positions.

The adjustable stops shall be set and secured in a reliable way.

The gear actuator shall be fitted with a position indicator.

On request, the manufacturer shall supply the number of turns that are necessary to complete a full opening or closing operation.

The design of the valve shall allow, with or without an intermediate part, mounting of a gear actuator with a plate complying with ISO 5211.

### 5.5.2.4 Disc position indication

The shaft end of the valve shall indicate the position of the disc, either by a permanent, non-erasable mark or by its shape.

## 5.6 Force or torque to be applied to manually actuated valves

### 5.6.1 Actuating force for handwheel or lever-actuated valves

At the CWP and the maximum flow velocity (see [Table 6](#)), the tangential force,  $F$ , to be applied to the handwheel (see [Figure 6](#)) or the lever (see [Figure 7](#)) to actuate the valve shall not exceed the values indicated in [Tables 3](#) and [4](#).

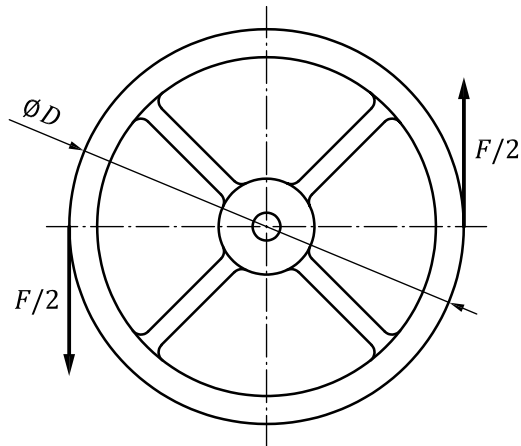

**Key**

$F$  tangential force

$D$  diameter of the handwheel

**Figure 6 — Tangential force to be applied to the handwheel**

**Table 3 — Tangential force to be applied to the handwheel**

Diameter of the handwheel $D$ mm	Tangential force $F$ N
$D \leq 125$	200
$125 < D \leq 250$	300
$250 < D \leq 500$	400

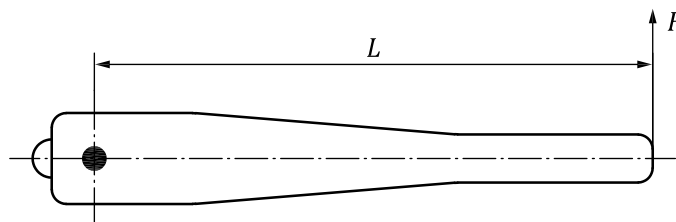

**Key**

$F$  tangential force

$L$  length of the lever

**Figure 7 — Tangential force to be applied to the lever**

**Table 4 — Tangential force to be applied to the lever**

Length of the lever $L$ mm	Tangential force $F$ N
$L \leq 250$	300
$250 < L \leq 500$	400

## 5.6.2 Actuating torque for T-wrench-actuated valves

The valves can be actuated using a gear reducer fitted with stops at the two extreme positions (for example buried valves). The stops shall be calculated to withstand the input torques resistance given in [Table 5](#).

Table 5

Nominal dimensions of square drive end mm	Minimum input torque resistance N·m
14	120
30	250
50	450

## 5.7 Dimensions and tolerances of body ends

### 5.7.1 General

When applied, threaded body flange holes shall allow full thread engagement to a depth at least equal to the nominal bolt diameter and at least 0,67 of the bolt diameter when the bolt hole is adjacent to the valve shaft.

For Class-designated valves, threaded body flange holes for bolts 1 inch or less in diameter shall be drilled and tapped in accordance with ASME B1.1, UNC coarse thread series, Class 2B. For bolts 1 1/8 inches or more in diameter, such holes shall be drilled and tapped in accordance with ASME B1.1, UN 8 eight thread series, Class 2B.

The technical documents of the valve manufacture shall specify the [Figure 3](#) valve configuration and whether or not a shut-off valve in an end-of-pipeline service is allowed. Any limitation regarding end-of-pipeline service shall be indicated.

### 5.7.2 Double-flanged ends

#### 5.7.2.1 Dimensions of flanges

PN-designated valves shall have bolt holes in accordance with the appropriate part of EN 1092-1, EN 1092-2 and EN 1092-3.

Class-designated valves shall have bolt holes in accordance with ASME B16.5 for NPS ≤ 24 or ASME B16.47 for NPS > 24.

In case of valve size outside the scope of EN 1092, ASME B16.5 or ASME B16.47, another flange standard may be used by agreement between the manufacturer and the purchaser. The wall thickness is to be calculated by linear interpolation from standards specified in [Table 2](#).

#### 5.7.2.2 Face-to-face dimensions

The face-to-face dimensions, unless otherwise specified in the purchasing documents, shall be in accordance with ISO 5752. The basic series required should be specified.

#### 5.7.2.3 Tolerances on face-to-face dimensions

Tolerances on face-to-face dimensions shall be in accordance with ISO 5752.



### 5.7.3 Body ends (wafer and flangeless valves)

#### 5.7.3.1 Dimensions of flanges

Body end of PN-designated valves shall be capable of mating with connecting flanges complying with the requirements of EN 1092-1, EN 1092-2 and EN 1092-3.

Body end of Class-designated valves shall be capable of mating with connecting flanges complying with the requirements of ASME B16.5 for NPS  $\leq 24$  or ASME B16.47 for NPS  $> 24$ .

In case of valve size outside the scope of EN 1092, ASME B16.5 or ASME B16.47, another flange standard may be used by agreement between the manufacturer and the purchaser. The wall thickness is to be calculated by linear interpolation from standards specified in [Table 2](#).

#### 5.7.3.2 Face-to-face dimensions

The face-to-face dimensions, unless otherwise specified in the purchasing documents, shall be in accordance with ISO 5752. The basic series required shall be specified by the purchaser.

In case of valve configuration outside the ranges covered by ISO 5752, the face-to-face dimensions may be defined by agreement between the manufacturer and the purchaser.

#### 5.7.3.3 Tolerances on face-to-face dimensions

Tolerances on face-to-face dimensions shall be in accordance with ISO 5752.

### 5.7.4 Surface finish of flanged and wafer valve ends requiring gasket

The gasket surface finish shall comply with the requirements of EN 1092-1, EN 1092-2 and EN 1092-3 for PN-designated valves, or ASME B16.5 for NPS  $\leq 24$  and ASME B16.47 for NPS  $> 24$  for Class-designated valves.

### 5.7.5 Valves with welded ends

Butt-welded ends shall be in accordance with the requirements of EN 1092-1:2007, Annex A, for PN-designated valves, or ASME B16.25 or ASME B16.34 for Class-designated valves.

## 6 Materials

### 6.1 Body

The materials to be used shall be the following:

- steel in accordance with ISO 3755, ISO 4991, ISO 9327-1, ISO 9327-2, ISO 9327-3, ISO 9327-4, ISO 9327-5, ISO 9328-1, ISO 9328-2, ISO 9328-3, ISO 9328-4, ISO 9328-5, EN 12516-1 or ASME B16.34;
- cast or ductile iron in accordance with ISO 185, ISO 1083, ISO 5922, EN 12516-4, ASME B16.1 or ASME B16.42;
- copper alloy in accordance with ISO 7005-3, EN 12516-4 or ASME B16.24.

The valve body may be coated, fully or partially, with an elastomer, polymer, or composite material as shown in the manufacturer's technical documents.

### 6.2 Disc

The materials to be used shall be the following:

- stainless steels;

- steel for pressure vessel in accordance with ISO 3755, ISO 4991, ISO 9327-1, ISO 9327-2, ISO 9327-3, ISO 9327-4, ISO 9327-5, ISO 9328-1, ISO 9328-2, ISO 9328-3, ISO 9328-4, ISO 9328-5, EN 12516-1 and ASME B16.34;
- cast iron in accordance with ISO 185, ISO 1083, ISO 5922, EN 12516-4, ASME B16.1 and ASME B16.42;
- copper alloy in accordance with ISO 7005-3, EN 12516-4 and ASME B16.24.

The valve disc may be coated, fully or partially, with an elastomer, polymer, or composite material as shown in the manufacturer's technical documents.

### 6.3 Shaft

The materials to be used shall be the following:

- stainless steels;
- copper alloys.

### 6.4 Seating

The materials to be used shall be the following:

- elastomeric;
- polymeric or composite;
- metallic.

## 7 Suitability of use

### 7.1 Allowable leakage rate

The leakage rate shall be as specified in ISO 5208 and shall be published in the valve manufacturer's literature.

### 7.2 Flow velocity

Valves shall be designed for flow velocities as given in [Table 6](#).

For values exceeding the limits specified in [Table 6](#), consult the manufacturer.

**Table 6 — Flow velocity as a function of flowing fluid**

Type of fluid	Velocity m/s		
	PN 2,5, PN 6, PN 10	PN 16, PN 25, PN 40	Class 125, 150, 300
Liquids	3	4	4
Gases	30		

## 8 Marking

Each PN-designated butterfly valve shall be marked in accordance with ISO 5209 as follows.

- a) For valves with DN < 50, only markings 1 to 4 are mandatory. They shall be placed on the valve body or on an attached plate.
- b) For all nominal diameters, the following markings are required:

- item 5 of ISO 5209:1977 if required by the valve type;
- item 6 of ISO 5209:1977 if required by the valve type;
- item 7 of ISO 5209:1977 if the valve application is restricted;
- design differential pressure, if lower than the CWP, shall be indicated.

NOTE Markings 8 to 19 of ISO 5209:1977 are optional.

Each Class-designated valve shall be marked in accordance with ASME B16.34.

## 9 Testing

**9.1** Each valve shall be pressure-tested in accordance with ISO 5208. All pressure tests shall be as prescribed in Table 1 of ISO 5208:2008.

**9.2** Additional examinations or tests may be applied upon agreement between the customer and the manufacturer.

## 10 Inspection and preparation for despatch

**10.1** The requirements in [Table 7](#) shall be verified by the manufacturer for each valve prior to shipment.

**10.2** The ports of the valves shall be suitably protected to avoid damage to the joint facings and deterioration of the non-metallic seals during transportation.

**Table 7 — Pre-shipment inspection requirements**

Requirement(s)	Examination(s)
<b>Type and trim:</b> The valve shall be in accordance with the order and product standard.	Check visually the type, its trim and accessories (for example handwheel and other items of the order).
<b>Marking</b>	Check visually to ensure that markings are complete and legible.
<b>Surface condition</b>	Examine visually to ensure exposed surfaces are free from defects that can affect safety or function.
<b>Coating</b>	Examine visually to determine that the specified coating has been applied.
<b>Operation</b>	Check that the valve opens and closes.

## 11 Example of data sheet

An example of a data sheet is given in [Annex A](#).

## Annex A (informative)

### Example of data sheet

<b>Valve data sheet</b> Information to be specified by the purchaser	
<b>Fluid</b>	— Type of fluid: ..... — Line pressure: ..... — Fluid temperature: ..... — Flow velocity: ..... — Differential pressure: .....
<b>Service</b>	<input type="checkbox"/> Shut off      Leakage rate: ISO 5208 <input type="checkbox"/> A <input type="checkbox"/> B <input type="checkbox"/> C <input type="checkbox"/> D <input type="checkbox"/> Throttling $q_{v,min.} = \dots\dots\dots m^3/h$ $p = \dots\dots\dots bar$ <input type="checkbox"/> Regulating $q_{v,max.} = \dots\dots\dots m^3/h$ $p = \dots\dots\dots bar$
<b>Designation/ material</b>	Designation according to ISO 10631 <div style="display: flex; justify-content: space-between; border: 1px solid black; padding: 2px;"> <span>Butterfly valve</span> <span>ISO 10631</span> <span>DN .....</span> <span>PN .....</span> <span>Basic series .....</span> </div> <div style="display: flex; justify-content: space-around; border: 1px solid black; padding: 2px; margin-top: 5px;"> <span>NPS .....</span> <span>Class .....</span> </div> <div style="display: flex; justify-content: space-between; border: 1px solid black; padding: 2px; margin-top: 5px;"> <span>End connection: Figure .....</span> <span>Construction example: Type .....</span> </div> Material according to ISO ..... <div style="display: flex; justify-content: space-around; border: 1px solid black; padding: 2px; margin-top: 5px;"> <div style="border: 1px solid black; padding: 2px; text-align: center;">Body .....</div> <div style="border: 1px solid black; padding: 2px; text-align: center;">Disc .....</div> <div style="border: 1px solid black; padding: 2px; text-align: center;">Seat .....</div> </div>
<b>Operation</b>	— Frequency of operation: ..... — Opening time: ..... — Closing time .....
<b>Actuation</b>	<input type="checkbox"/> Hand <input type="checkbox"/> Wrench <input type="checkbox"/> Gear <input type="checkbox"/> Automatic <input type="checkbox"/> Pneumatic <input type="checkbox"/> Electric <input type="checkbox"/> Hydraulic <input type="checkbox"/> Double-acting <input type="checkbox"/> single-action <input type="checkbox"/> Failsafe normally open "NO" <input type="checkbox"/> Failsafe normally closed "NC"
<b>Additional requirements</b>	<input type="checkbox"/> Fire-tested design specified by the customer ..... <input type="checkbox"/> Antistatic design ..... <input type="checkbox"/> Limit switch box ..... <input type="checkbox"/> Emergency hand control ..... <input type="checkbox"/> Special coating ..... <input type="checkbox"/> Others (specify) .....

## Bibliography

- [1] ISO 6708, *Pipework components — Definition and selection of DN (nominal size)*
- [2] ISO 7121, *Steel ball valves for general-purpose industrial applications*
- [3] ISO 7268, *Pipe components — Definition of nominal pressure*
- [4] EN 593+A1, *Industrial valves — Metallic butterfly valves*
- [5] IEC 60534-2-3, *Industrial-process control valves — Part 2-3: Flow capacity — Test procedures*
- [6] ASME, *Boiler and Pressure Vessel Code — 2010 edition, Section VIII Division 1 and Division 2*
- [7] EN 13445-3, *Unfired pressure vessels — Part 3: Design*





# British Standards Institution (BSI)

BSI is the national body responsible for preparing British Standards and other standards-related publications, information and services.

BSI is incorporated by Royal Charter. British Standards and other standardization products are published by BSI Standards Limited.

## About us

We bring together business, industry, government, consumers, innovators and others to shape their combined experience and expertise into standards-based solutions.

The knowledge embodied in our standards has been carefully assembled in a dependable format and refined through our open consultation process. Organizations of all sizes and across all sectors choose standards to help them achieve their goals.

## Information on standards

We can provide you with the knowledge that your organization needs to succeed. Find out more about British Standards by visiting our website at [bsigroup.com/standards](http://bsigroup.com/standards) or contacting our Customer Services team or Knowledge Centre.

## Buying standards

You can buy and download PDF versions of BSI publications, including British and adopted European and international standards, through our website at [bsigroup.com/shop](http://bsigroup.com/shop), where hard copies can also be purchased.

If you need international and foreign standards from other Standards Development Organizations, hard copies can be ordered from our Customer Services team.

## Subscriptions

Our range of subscription services are designed to make using standards easier for you. For further information on our subscription products go to [bsigroup.com/subscriptions](http://bsigroup.com/subscriptions).

With **British Standards Online (BSOL)** you'll have instant access to over 55,000 British and adopted European and international standards from your desktop. It's available 24/7 and is refreshed daily so you'll always be up to date.

You can keep in touch with standards developments and receive substantial discounts on the purchase price of standards, both in single copy and subscription format, by becoming a **BSI Subscribing Member**.

**PLUS** is an updating service exclusive to BSI Subscribing Members. You will automatically receive the latest hard copy of your standards when they're revised or replaced.

To find out more about becoming a BSI Subscribing Member and the benefits of membership, please visit [bsigroup.com/shop](http://bsigroup.com/shop).

With a **Multi-User Network Licence (MUNL)** you are able to host standards publications on your intranet. Licences can cover as few or as many users as you wish. With updates supplied as soon as they're available, you can be sure your documentation is current. For further information, email [bsmusales@bsigroup.com](mailto:bsmusales@bsigroup.com).

## BSI Group Headquarters

389 Chiswick High Road London W4 4AL UK

## Revisions

Our British Standards and other publications are updated by amendment or revision.

We continually improve the quality of our products and services to benefit your business. If you find an inaccuracy or ambiguity within a British Standard or other BSI publication please inform the Knowledge Centre.

## Copyright

All the data, software and documentation set out in all British Standards and other BSI publications are the property of and copyrighted by BSI, or some person or entity that owns copyright in the information used (such as the international standardization bodies) and has formally licensed such information to BSI for commercial publication and use. Except as permitted under the Copyright, Designs and Patents Act 1988 no extract may be reproduced, stored in a retrieval system or transmitted in any form or by any means – electronic, photocopying, recording or otherwise – without prior written permission from BSI. Details and advice can be obtained from the Copyright & Licensing Department.

## Useful Contacts:

### Customer Services

**Tel:** +44 845 086 9001

**Email (orders):** [orders@bsigroup.com](mailto:orders@bsigroup.com)

**Email (enquiries):** [cservices@bsigroup.com](mailto:cservices@bsigroup.com)

### Subscriptions

**Tel:** +44 845 086 9001

**Email:** [subscriptions@bsigroup.com](mailto:subscriptions@bsigroup.com)

### Knowledge Centre

**Tel:** +44 20 8996 7004

**Email:** [knowledgecentre@bsigroup.com](mailto:knowledgecentre@bsigroup.com)

### Copyright & Licensing

**Tel:** +44 20 8996 7070

**Email:** [copyright@bsigroup.com](mailto:copyright@bsigroup.com)



...making excellence a habit.™