

BS ISO 10555-6:2015



BSI Standards Publication

Intravascular catheters — Sterile and single-use catheters

Part 6: Subcutaneous implanted ports

bsi.

...making excellence a habit.™

National foreword

This British Standard is the UK implementation of ISO 10555-6:2015.

The UK participation in its preparation was entrusted to Technical Committee CH/84, Catheters and syringes.

A list of organizations represented on this committee can be obtained on request to its secretary.

This publication does not purport to include all the necessary provisions of a contract. Users are responsible for its correct application.

© The British Standards Institution 2015. Published by BSI Standards Limited 2015

ISBN 978 0 580 78730 0

ICS 11.040.25

Compliance with a British Standard cannot confer immunity from legal obligations.

This British Standard was published under the authority of the Standards Policy and Strategy Committee on 30 April 2015.

Amendments issued since publication

Date	Text affected
------	---------------

INTERNATIONAL
STANDARD

ISO
10555-6

First edition
2015-04-15

**Intravascular catheters — Sterile and
single-use catheters —**

Part 6:
Subcutaneous implanted ports

*Cathéters intravasculaires — Cathéters stériles et non réutilisables —
Partie 6: Chambres à cathéter implantables*



Reference number
ISO 10555-6:2015(E)



COPYRIGHT PROTECTED DOCUMENT

© ISO 2015

All rights reserved. Unless otherwise specified, no part of this publication may be reproduced or utilized otherwise in any form or by any means, electronic or mechanical, including photocopying, or posting on the internet or an intranet, without prior written permission. Permission can be requested from either ISO at the address below or ISO's member body in the country of the requester.

ISO copyright office
Case postale 56 • CH-1211 Geneva 20
Tel. + 41 22 749 01 11
Fax + 41 22 749 09 47
E-mail copyright@iso.org
Web www.iso.org

Published in Switzerland

Contents

Page

Foreword	iv
1 Scope	1
2 Normative references	1
3 Terms and definitions	1
4 Requirements of the implantable subcutaneous implanted port and catheter	3
4.1 General.....	3
4.2 Biocompatibility.....	4
4.3 Distance markings.....	4
4.4 Nominal dimensions of the subcutaneous implanted port.....	4
4.5 Physical requirements.....	4
4.5.1 Radio-detectability.....	4
4.5.2 Surface finish.....	4
4.5.3 Freedom from leakage.....	4
4.5.4 Flushing volume.....	4
4.5.5 Characteristics of the septum.....	5
4.5.6 Characteristics of the connection or the catheter.....	5
4.6 Flow rate.....	5
4.6.1 Subcutaneous implanted ports not indicated for power injection.....	5
4.6.2 Subcutaneous implanted ports indicated for power injection.....	5
4.7 Burst pressure of the subcutaneous implanted port and catheter.....	6
4.7.1 Subcutaneous implanted ports not indicated for power injection.....	6
4.7.2 Subcutaneous implanted ports indicated for power injection.....	6
5 Magnetic Resonance Imaging (MRI) compatibility	6
6 Information to be supplied by the manufacturer	6
6.1 Marking on the device.....	6
6.2 Primary packaging.....	6
6.3 Labels for traceability.....	7
6.4 Instruction for use.....	7
Annex A (normative) Test method for freedom from air leakage	8
Annex B (informative) Determination of flushing volume	10
Annex C (informative) Guidance on further characterization testing: Needle penetration and withdrawal	12
Annex D (normative) Test method for freedom from leakage after multiple punctures	14
Annex E (normative) Peak tensile force	15
Bibliography	16

Foreword

ISO (the International Organization for Standardization) is a worldwide federation of national standards bodies (ISO member bodies). The work of preparing International Standards is normally carried out through ISO technical committees. Each member body interested in a subject for which a technical committee has been established has the right to be represented on that committee. International organizations, governmental and non-governmental, in liaison with ISO, also take part in the work. ISO collaborates closely with the International Electrotechnical Commission (IEC) on all matters of electrotechnical standardization.

The procedures used to develop this document and those intended for its further maintenance are described in the ISO/IEC Directives, Part 1. In particular the different approval criteria needed for the different types of ISO documents should be noted. This document was drafted in accordance with the editorial rules of the ISO/IEC Directives, Part 2 (see www.iso.org/directives).

Attention is drawn to the possibility that some of the elements of this document may be the subject of patent rights. ISO shall not be held responsible for identifying any or all such patent rights. Details of any patent rights identified during the development of the document will be in the Introduction and/or on the ISO list of patent declarations received (see www.iso.org/patents).

Any trade name used in this document is information given for the convenience of users and does not constitute an endorsement.

For an explanation on the meaning of ISO specific terms and expressions related to conformity assessment, as well as information about ISO's adherence to the WTO principles in the Technical Barriers to Trade (TBT) see the following URL: [Foreword - Supplementary information](#)

The committee responsible for this document is ISO/TC 84, *Devices for administration of medicinal products and intravascular catheters*.

ISO 10555 consists of the following parts, under the general title *Intravascular catheters — Sterile and single-use catheters*:

- *Part 1: General requirements*
- *Part 3: Central venous catheters*
- *Part 4: Balloon dilatation catheters*
- *Part 5: Over-needle peripheral catheters*
- *Part 6: Subcutaneous implanted ports*

The following part has been withdrawn and the content has been included in ISO 10555-1:

- *Part 2: Angiographic catheters*

Intravascular catheters — Sterile and single-use catheters —

Part 6: Subcutaneous implanted ports

1 Scope

This part of ISO 10555 specifies requirements, performance, and user safety issues related to subcutaneous implanted ports and catheters for intravascular long-term use supplied in sterile condition and intended for single use.

This part of ISO 10555 does not specify requirements, performance, and user safety issues related to non-coring needles.

NOTE Subcutaneous implanted ports are known to be used for indications other than intravascular such as intra-peritoneal, intra-theical, intra-pleural, and epidural access.

2 Normative references

The following documents, in whole or in part, are normatively referenced in this document and are indispensable for its application. For dated references, only the edition cited applies. For undated references, the latest edition of the referenced document (including any amendments) applies.

ISO 10555-1:2013, *Intravascular catheters — Sterile and single-use catheters — Part 1: General requirements*

ISO 10555-3:2013, *Intravascular catheters — Sterile and single-use catheters — Part 3: Central venous catheters*

3 Terms and definitions

For the purposes of this document, the terms and definitions given in ISO 10555-1 and the following apply.

3.1 catheter

single- or multiple-lumen tube allowing access to a point within the body at its distal end

3.2 connection

system connecting the catheter to the subcutaneous implanted port

3.3 effective surface area

area available for puncture by the needle

3.4 flushing volume

volume of solution needed to fully replace one solution from the subcutaneous implanted port and catheter with another

3.5
non-coring needle

needle that does not produce a core when penetrating the septum

Note 1 to entry: Core is a sliver of septum material that can be produced when a needle perforates a septum.

3.6
outlet tube

exit cannula portion of the subcutaneous implanted port that is connected to the catheter

3.7
priming volume

total amount of space available in the subcutaneous implanted port and catheter to be filled with solution

3.8
priming volume of the subcutaneous implanted port

amount of space available in the subcutaneous implanted port to be filled with solution, where the space is comprised of both the reservoir and outlet tube

3.9
priming volume of the catheter

total amount of space available in the effective length of the catheter to be filled with solution

3.10
reservoir

open space below the septum that receives the needle and is in communication with the outlet tube

3.11
septum

self-sealing membrane through which the needle passes to communicate with the catheter

3.12
subcutaneous implanted port

device which permits percutaneous access to the catheter

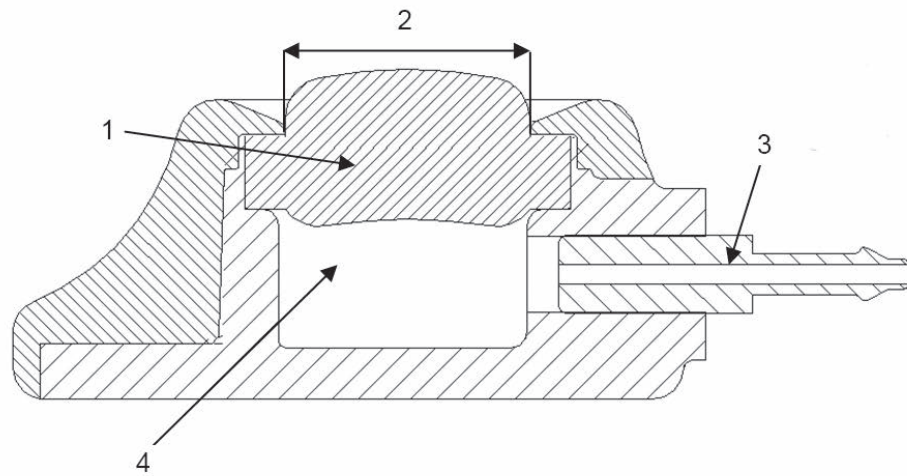

Key

- 1 septum
- 2 effective surface area
- 3 outlet tube
- 4 reservoir

Figure 1 — Subcutaneous implanted port

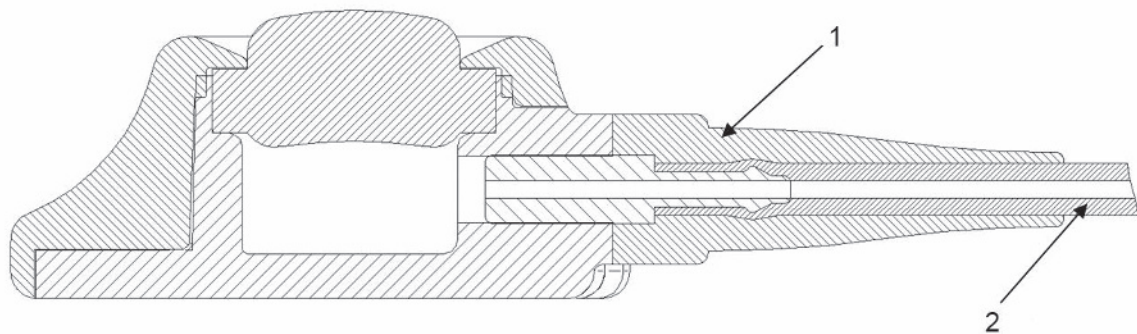

Key

- 1 connection
- 2 catheter

Figure 2 — Subcutaneous implanted port connected to a catheter

4 Requirements of the implantable subcutaneous implanted port and catheter

4.1 General

Unless otherwise specified in this part of ISO 10555, the subcutaneous implanted port and catheter shall comply with ISO 10555-1.

4.2 Biocompatibility

Subcutaneous implantable port shall be free from biological hazards.

NOTE See ISO 10993-1 for the selection of appropriate test methods.

4.3 Distance markings

If the catheter is provided with distance markings, the marking shall be indicated as follows:

- a) for non-connected catheters, indicate distance from the distal end of the catheter;
- b) for pre-connected catheters, indicate distance from the proximal end of the catheter.

From the first mark, the distance between marks shall not exceed 5 cm.

It is recommended that the distance marks be 1 cm apart on that portion of the catheter likely to be of importance to the user in positioning the catheter and monitoring catheter migration.

4.4 Nominal dimensions of the subcutaneous implanted port

If provided, the following measurements shall be expressed in millimetres:

- subcutaneous implanted port dimensions;
- effective surface area of the septum, defined either as the diameter (in case of a circular septum) or as the length and width (in case of other shape) of the septum in nominal dimension.

4.5 Physical requirements

4.5.1 Radio-detectability

The radio-detectability shall comply with ISO 10555-1 and shall include the catheter, subcutaneous implanted port, and connection.

4.5.2 Surface finish

When examined by normal or corrected to normal vision, with a minimum x2,5 magnification, the surface of the subcutaneous implanted port shall appear free from extraneous matter.

4.5.3 Freedom from leakage

The connection or any other part of the subcutaneous implanted port shall not leak air when tested in accordance with the method given in [Annex A](#).

When the test is conducted according to [Annex A](#), the subcutaneous implanted port is considered to leak if the reduction in pressure is greater than 2,65 kPa in 2 min or if a level of 200 kPa cannot be attained.

The septum of the subcutaneous implanted port shall not leak air when tested in accordance with the method given in [Annex D](#).

4.5.4 Flushing volume

The manufacturer shall conduct characterization tests for the flushing volume. A test method is described in [Annex B](#). Any other equivalent method may be used.

4.5.5 Characteristics of the septum

4.5.5.1 Needle penetration and withdrawal force

If tested in accordance with [Annex C](#), the peak force of penetration and withdrawal of a non-coring needle recommended by the manufacturer should be determined.

4.5.6 Characteristics of the connection or the catheter

4.5.6.1 Peak tensile force

For the connection between the port and the catheter, the minimum peak tensile force shall be 5 N when tested in accordance with [Annex E](#).

The minimum peak tensile force of all other parts of the catheter shall comply with ISO 10555-3:2013, 4.4.

4.6 Flow rate

For devices for which flow rate is defined, when tested in accordance with ISO 10555-1:2013, Annex E, the flow rate for each lumen shall be a minimum of 80 % of that stated by the manufacturer for catheters of nominal outside diameter less than 1,0 mm or a minimum of 90 % of that stated by the manufacturer for catheters of nominal outside diameter equal to 1,0 mm or greater.

If the flowrate through hydratable catheters is determined, it shall be determined in post-hydration states.

4.6.1 Subcutaneous implanted ports not indicated for power injection

When tested in accordance with the method given in ISO 10555-1:2013, Annex E, the following modifications shall be made to the test apparatus:

- the male 6 % (luer) taper fitting ISO 10555-1:2013, Figure E.1 component 6 shall be connected to the hub of a non-coring needle;
- the non-coring needle shall be placed through the septum of the subcutaneous implanted port;
- the subcutaneous implanted port shall be connected to the catheter under test (ISO 10555-1:2013, Figure E.1 component 7) following manufacturer instructions;
- an inline pressure transducer shall be connected to the proximal end of the non-coring needle.

The test shall be completed with non-coring needles that characterize the minimum and maximum flow rate under gravity. The needle gauge and length shall be recorded.

4.6.2 Subcutaneous implanted ports indicated for power injection

When tested in accordance with the method given in ISO 10555-1:2013, Annex G, the following modifications shall be made to the test apparatus:

- the locking device (ISO 10555-1:2013, Figure G.1 component 4) shall be connected to the hub of a non-coring needle indicated for power injection;
- the non-coring needle shall be placed through the septum of the subcutaneous implanted port;
- the subcutaneous implanted port shall be connected to the catheter under test (ISO 10555-1:2013, Figure G.1, component 6) following manufacturer instructions.

4.7 Burst pressure of the subcutaneous implanted port and catheter

When tested in accordance with the method given in ISO 10555-1:2013, Annex F, the following modifications shall be made to the test apparatus:

- the locking device fitting (ISO 10555-1:2013, F.2.3 and Figure F.1 component 3) shall be connected to the hub of a non-coring needle according to the appropriate risk-based clinical justification;
- the non-coring needle shall be placed through the septum of the subcutaneous implanted port;
- the subcutaneous implanted port shall be connected to the catheter under test (ISO 10555-1:2013, Figure F.1 component 5) following manufacturer instructions.

4.7.1 Subcutaneous implanted ports not indicated for power injection

When tested in accordance with the method given in ISO 10555-1:2013, Annex F with the above modifications (see 4.7), the burst pressure shall exceed the peak pressure present at maximum flow conditions as determined by 4.6.1.

4.7.2 Subcutaneous implanted ports indicated for power injection

When tested in accordance with the method given in ISO 10555-1:2013, Annex F with the above modifications (see 4.7), the burst pressure shall exceed the peak pressure present at maximum flow conditions as determined by 4.6.2.

5 Magnetic Resonance Imaging (MRI) compatibility

The hazards of subcutaneous implanted ports in the magnetic resonance environment should be evaluated by an appropriate method.

NOTE Such as ASTM F2052, F2213, F2182, and F2119.

6 Information to be supplied by the manufacturer

Information supplied by the manufacturer shall comply with ISO 10555-1 and shall also include the following.

6.1 Marking on the device

Information for product traceability shall be placed on the subcutaneous implanted port by the appropriate method such as direct marking by inkjet or laser.

NOTE A model number and, if applicable, indication for power injection can be added.

This information can be supplied in the form of an identification number or two dimensional symbol specified by GS-1 (Global Standard One) system.

6.2 Primary packaging

The primary packaging shall comply with ISO 10555-1 and shall also contain at least some information on the following:

- indication for power injection.

6.3 Labels for traceability

Three self-adhesive labels shall contain, as a minimum, the following:

- the name of the product and manufacturer;
- designation and item number;
- the batch code, LOT, or serial number.

6.4 Instruction for use

The instruction for use shall comply with ISO 10555-1 and shall also contain at least information on the following:

- a) technique for subcutaneous implanted port placement;
- b) the nature (generic name) of the constituent materials of the subcutaneous implanted port;
- c) priming volume of the subcutaneous implanted port;
- d) priming volume of the catheter per 10 cm;
- e) if applicable, safety information in the magnetic resonance environment;
- f) gravity flow rate in ml/min (power injection flow rate, if applicable, ml/s);
- g) if applicable, specifications of the devices required to connect the port to the power injector shall be indicated (e.g. dimensions of non-coring needle, extension lines).

NOTE Units of measurement systems other than those specified in this part of ISO 10555 can additionally be given.

Annex A (normative)

Test method for freedom from air leakage

A.1 Principle

Air pressure is applied to the connection and the subcutaneous implanted port to determine if air leakage is found.

A.2 Apparatus

A.2.1 Leak-proof connector.

A.2.2 Syringe, or constant pressure source.

A.2.3 Gauge, capable of measuring up to 300 kPa pressure.

A.2.4 Fluid-filled, temperature controlled test chamber.

A.3 Procedure

A.3.1 Bring the test chamber fluid ([A.2.4](#)) to a temperature of (37 ± 2) °C, and maintain this temperature throughout the test.

A.3.2 Attach the catheter to the port, if it is a non-connected catheter.

A.3.3 Cut the catheter distal to the port leaving a length of catheter sufficient (max. 10 cm) to allow connection of the pressure gauge and pressure source.

A.3.4 Connect the distal end of the catheter to the pressure source and pressure gauge via a leak-proof connector.

A.3.5 Immerse the subcutaneous implanted port in the temperature controlled test chamber.

A.3.6 Allow the subcutaneous implanted port to reach thermal equilibrium.

A.3.7 Adjust the pressure to a minimum of 200 kPa and wait 2 min.

A.3.8 Examine the assembled subcutaneous implanted port for air leakage (which is a pressure reduction greater than 2,65 kPa in 2 min or if a level of 200 kPa cannot be attained).

A.4 Test Report

The test report shall include the following information:

a) identity of the subcutaneous implanted port;

b) statement whether there is air leakage.

Annex B (informative)

Determination of flushing volume

B.1 Principle

The subcutaneous implanted port and the catheter are filled with a coloured solution and flushed with successive boli until the colour disappears.

B.2 Reagents

B.2.1 Glycerine.

B.2.2 NaCl 9 g/l.

B.2.3 Patent blue V colourant ($\lambda = 635 \text{ nm}$).

NOTE Patent blue V is an example of a suitable product available commercially. This information is given for the convenience of users of this European Standard and does not constitute an endorsement by ISO (CEN) of this product.

B.3 Apparatus

B.3.1 Non-coring needle.

B.3.2 Syringe.

B.3.3 Spectrophotometer, capable of measuring absorbency at 635 nm.

B.4 Procedure

B.4.1 Prepare 400 ml of NaCl 9 g/l as flushing solution.

B.4.2 Prepare 100 ml of coloured solution (100 ml of 45 % glycerine by weight + 55 % solution NaCl 9 g/l (simulation of blood viscosity) containing 2 mg of patent blue V colourant).

B.4.3 Cut X cm of catheter (e.g. X = 25 cm + outlet tube length) and connect it to the subcutaneous implanted port with the connection according to the manufacturer's instructions for use.

B.4.4 Fill the subcutaneous implanted port and the catheter with sufficient coloured solution.

B.4.5 Flush each subcutaneous implanted port with a 2 ml bolus of flushing solution without shaking it.

B.4.6 Collect the flushed solution in a test tube. Measure the collected solution and repeat flushing and measuring until the coloured solution vanishes by collecting each bolus separately and by indicating the number of successive rinses.

B.4.7 The sum of the boli until the colouring disappears is the flushing volume of the device.

B.5 Test Report

The test report shall include the following information:

- a) identity of the subcutaneous implanted port and catheter;
- b) total flushing volume expressed in ml;
- c) length of catheter expressed in cm.

Annex C (informative)

Guidance on further characterization testing: Needle penetration and withdrawal

C.1 Principle

The septum is punctured with a non-coring needle and the peak forces of penetration and withdrawal are recorded.

C.2 Apparatus

C.2.1 **Tensile/compression test machine.**

C.2.2 **Fixture**, which holds the needle perpendicular to the subcutaneous implanted port.

C.3 Procedure

C.3.1 Place the test pieces to be conditioned in an appropriate aqueous medium at (37 ± 2) °C for a clinically appropriate period of time. Test in accordance with [C.3.2](#) to [C.3.3](#) immediately after conditioning.

C.3.2 Perform needle penetration force test as follows:

C.3.2.1 Program the test machine with a test speed of 50 mm/min in compression mode.

C.3.2.2 Place the subcutaneous implanted port on the support-plate of the test machine.

C.3.2.3 Insert the fixture which holds the needle perpendicular to the septum surface into the upper jaws.

C.3.2.4 Position the needle just above the puncture surface.

C.3.2.5 Insert needle into the septum of the subcutaneous implanted port such that the needle crosses the septum but does not come into contact with the bottom of the subcutaneous implanted port.

C.3.2.6 Record the peak penetration force.

C.3.3 Perform needle withdrawal force test as follows:

C.3.3.1 Program the test machine with a test speed of 50 mm/min in extension mode.

C.3.3.2 Withdraw the needle completely from the septum of the subcutaneous implanted port.

C.3.3.3 Record the peak withdrawal force.

C.4 Test Report

The test report shall include the following information:

- a) identity of the subcutaneous implanted port, diameter and identity of the needle, and presence or not of lubricant on the needle body;
- b) peak force of septum penetration and withdrawal.

Annex D (normative)

Test method for freedom from leakage after multiple punctures

D.1 Principle

Randomly distribute an appropriate number of needle punctures over the effective area of the septum, then the port is leak tested in accordance with [Annex A](#).

D.2 Apparatus

D.2.1 **Apparatus** requested by [Annex A](#).

D.2.2 **Non-coring needles**, recommended by the manufacturer.

D.2.3 **Testing equipment**, for producing punctures.

D.3 Procedure

D.3.1 Bring the test chamber fluid ([A.2.4](#)) to a temperature of (37 ± 2) °C, and maintain this temperature throughout the test.

D.3.2 Immerse the subcutaneous implanted port in the temperature-controlled test chamber and allow it to reach thermal equilibrium.

D.3.3 Perform punctures keeping the subcutaneous implanted port in the temperature-controlled test chamber.

The number of punctures should be as follows:

Minimum 1 000 punctures per cm² of effective surface area of septum.

If the manufacturer claims resistance to a higher number of punctures, that number shall be considered for this test. Punctures are randomly distributed over the effective surface area of the septum. Ensure that the non-coring needle tip completely passes through the septum at each puncture. Each needle shall be used for a maximum of 50 punctures. Check carefully that the needle tip is not tilted or rocked after exiting the septum; if this occurs, replace the non-coring needle.

D.3.4 Conduct leak test in accordance with [Annex A](#).

D.4 Test report

The test report shall include the following information:

- a) identity of tested subcutaneous implanted port and non-coring needles;
- b) number of punctures;
- c) statement as to whether leakage was observed after punctures.

Annex E (normative)

Peak tensile force

E.1 Principle

The catheter is connected to the subcutaneous implanted port in accordance with the manufacturer's instructions for use. Tensile force is applied to the connection until the junction separates or the catheter breaks.

E.2 Apparatus

Tensile testing equipment, capable of exerting a force greater than 10 N.

E.3 Procedure

E.3.1 Place the test pieces to be conditioned in an appropriate aqueous medium at (37 ± 2) °C for a clinically appropriate period of time. Test in accordance with [E.3.2](#) to [E.3.4](#) immediately after conditioning.

E.3.2 Tensile speed: 50 mm/min.

E.3.3 Connect the catheter to the subcutaneous implanted port in accordance with the manufacturer's instructions. Fix the test sample in the tensile testing equipment.

E.3.4 Apply the tensile force until the junction separates or the catheter breaks.

E.4 Test report

The test report shall include the following information:

- a) identity of the subcutaneous implanted port and the catheter;
- b) peak tensile force expressed in newtons.

Bibliography

- [1] ISO 48, *Rubber, vulcanized or thermoplastic — Determination of hardness (hardness between 10 IRHD and 100 IRHD)*
- [2] ISO 594-1¹⁾, *Conical fittings with a 6 % (Luer) taper for syringes, needles and certain other medical equipment — Part 1: General requirements*
- [3] ISO 5832-1, *Implants for surgery — Metallic materials — Part 1: Wrought stainless steel*
- [4] ISO 5832-2, *Implants for surgery — Metallic materials — Part 2: Unalloyed titanium*
- [5] ISO 6474-1, *Implants for surgery — Ceramic materials — Part 1: Ceramic materials based on high purity alumina*
- [6] ISO 7864, *Sterile hypodermic needles for single use*
- [7] ISO 9584, *Implants for surgery — Non-destructive testing — Radiographic examination of cast metallic surgical implants*
- [8] ISO 10993-1, *Biological evaluation of medical devices — Part 1: Evaluation and testing within a risk management process*
- [9] ISO 11135-1, *Sterilization of health care products — Ethylene oxide — Part 1: Requirements for development, validation and routine control of a sterilization process for medical devices*
- [10] ISO 17665-1, *Sterilization of health care products — Moist heat — Part 1: Requirements for the development, validation and routine control of a sterilization process for medical devices*
- [11] ASTM F2052-06e1, *Standard Test Method for Measurement of Magnetically Induced Displacement Force on Medical Devices in the Magnetic Resonance Environment*
- [12] ASTM F2213-06, *Standard Test Method for Measurement of Magnetically Induced Torque on Medical Devices in the Magnetic Resonance Environment*
- [13] ASTM F2182-11a, *Standard Test Method for Measurement of Radio Frequency Induced Heating On or Near Passive Implants during Magnetic Resonance Imaging*
- [14] ASTM F2119-07 *Standard Test Method for Evaluation of MR Image Artifacts from Passive Implants*
- [15] Central venous access port devices - a pictorial review of common complications from the interventional radiology perspective. 2012 Jan-Mar;13(1):9-15. [Ananthakrishnan G, McDonald R, Moss J, Kasthuri R](#). Source Department Interventional Radiology, Gartnavel General Hospital, Glasgow, UK. ganapathy.ananthakrishnan@nhs.net Available from <http://www.ncbi.nlm.nih.gov/pubmed/21725953>
- [16] GAVeCeLT* consensus statement on the correct use of totally implantable venous access devices for diagnostic radiology procedures. 2011 Oct-Dec;12(4):292-305 [Bonciarelli G, Batacchi S, Biffi R, Buononato M, Damascelli B, Ghibauda F, Orsi F, Pittiruti M, Scoppettuolo G, Verzè A, Borasi G, De Cicco M, Dosio R, Gazzo P, Maso R, Roman A, Ticha V, Venier G, Blackburn P, Goossens GA, Bowen Santolucito J, Stas M, Van Boxtel T, Vesely TM, de Lutio E; Gruppo Aperto di Studio Accessi Venosi Centrali a Lungo Termine \(Study Group on Long-Term Central Venous Access\)](#). Source Medical Oncology Unit, Azienda ULSS 17, Este, Monselice, Italy. Available at: <http://www.ncbi.nlm.nih.gov/pubmed/21534233>
- [17] Radio-opacity and incidental identified mechanical complications of totally implantable venous access devices placed in the chest, November 2012; vol. 53, 9: pp. 1035-1039, Alexey Surov, Carsten Rusner, Karl Weigand, Endres John, Rolf Peter Spielmann, and C

1) Upon its publication, ISO 80369-7 will replace ISO 594-1.

Behrmann. Acta Radiol. 2012 November, **53** (9) pp. 1035–1039. Available at: http://acr.sagepub.com/search/results?fulltext=Radio-opacity&submit=yes&journal_set=spacr&src=selected&andorexactfulltext=and&x=6&y=14

British Standards Institution (BSI)

BSI is the national body responsible for preparing British Standards and other standards-related publications, information and services.

BSI is incorporated by Royal Charter. British Standards and other standardization products are published by BSI Standards Limited.

About us

We bring together business, industry, government, consumers, innovators and others to shape their combined experience and expertise into standards-based solutions.

The knowledge embodied in our standards has been carefully assembled in a dependable format and refined through our open consultation process. Organizations of all sizes and across all sectors choose standards to help them achieve their goals.

Information on standards

We can provide you with the knowledge that your organization needs to succeed. Find out more about British Standards by visiting our website at bsigroup.com/standards or contacting our Customer Services team or Knowledge Centre.

Buying standards

You can buy and download PDF versions of BSI publications, including British and adopted European and international standards, through our website at bsigroup.com/shop, where hard copies can also be purchased.

If you need international and foreign standards from other Standards Development Organizations, hard copies can be ordered from our Customer Services team.

Subscriptions

Our range of subscription services are designed to make using standards easier for you. For further information on our subscription products go to bsigroup.com/subscriptions.

With **British Standards Online (BSOL)** you'll have instant access to over 55,000 British and adopted European and international standards from your desktop. It's available 24/7 and is refreshed daily so you'll always be up to date.

You can keep in touch with standards developments and receive substantial discounts on the purchase price of standards, both in single copy and subscription format, by becoming a **BSI Subscribing Member**.

PLUS is an updating service exclusive to BSI Subscribing Members. You will automatically receive the latest hard copy of your standards when they're revised or replaced.

To find out more about becoming a BSI Subscribing Member and the benefits of membership, please visit bsigroup.com/shop.

With a **Multi-User Network Licence (MUNL)** you are able to host standards publications on your intranet. Licences can cover as few or as many users as you wish. With updates supplied as soon as they're available, you can be sure your documentation is current. For further information, email bsmusales@bsigroup.com.

BSI Group Headquarters

389 Chiswick High Road London W4 4AL UK

Revisions

Our British Standards and other publications are updated by amendment or revision.

We continually improve the quality of our products and services to benefit your business. If you find an inaccuracy or ambiguity within a British Standard or other BSI publication please inform the Knowledge Centre.

Copyright

All the data, software and documentation set out in all British Standards and other BSI publications are the property of and copyrighted by BSI, or some person or entity that owns copyright in the information used (such as the international standardization bodies) and has formally licensed such information to BSI for commercial publication and use. Except as permitted under the Copyright, Designs and Patents Act 1988 no extract may be reproduced, stored in a retrieval system or transmitted in any form or by any means – electronic, photocopying, recording or otherwise – without prior written permission from BSI. Details and advice can be obtained from the Copyright & Licensing Department.

Useful Contacts:

Customer Services

Tel: +44 845 086 9001

Email (orders): orders@bsigroup.com

Email (enquiries): cservices@bsigroup.com

Subscriptions

Tel: +44 845 086 9001

Email: subscriptions@bsigroup.com

Knowledge Centre

Tel: +44 20 8996 7004

Email: knowledgecentre@bsigroup.com

Copyright & Licensing

Tel: +44 20 8996 7070

Email: copyright@bsigroup.com



...making excellence a habit.™