

BS ISO 10302-1:2011



BSI Standards Publication

Acoustics — Measurement of airborne noise emitted and structure-borne vibration induced by small air-moving devices

Part 1: Airborne noise measurement

bsi.

...making excellence a habit.™

National foreword

This British Standard is the UK implementation of ISO 10302-1:2011. It supersedes BS 848-2.6:2000 which is withdrawn.

The UK participation in its preparation was entrusted to Technical Committee EH/1, Acoustics.

A list of organizations represented on this committee can be obtained on request to its secretary.

This publication does not purport to include all the necessary provisions of a contract. Users are responsible for its correct application.

© BSI 2011

ISBN 978 0 580 67285 9

ICS 17.140.20; 23.120

Compliance with a British Standard cannot confer immunity from legal obligations.

This British Standard was published under the authority of the Standards Policy and Strategy Committee on 31 January 2011.

Amendments issued since publication

Date	Text affected
------	---------------

**Acoustics — Measurement of airborne
noise emitted and structure-borne
vibration induced by small air-moving
devices —**

Part 1:
Airborne noise measurement

*Acoustique — Mesurage du bruit aérien émis et des vibrations de
structure induites par les petits équipements de ventilation —*

Partie 1: Mesurage du bruit aérien



PDF disclaimer

This PDF file may contain embedded typefaces. In accordance with Adobe's licensing policy, this file may be printed or viewed but shall not be edited unless the typefaces which are embedded are licensed to and installed on the computer performing the editing. In downloading this file, parties accept therein the responsibility of not infringing Adobe's licensing policy. The ISO Central Secretariat accepts no liability in this area.

Adobe is a trademark of Adobe Systems Incorporated.

Details of the software products used to create this PDF file can be found in the General Info relative to the file; the PDF-creation parameters were optimized for printing. Every care has been taken to ensure that the file is suitable for use by ISO member bodies. In the unlikely event that a problem relating to it is found, please inform the Central Secretariat at the address given below.



COPYRIGHT PROTECTED DOCUMENT

© ISO 2011

All rights reserved. Unless otherwise specified, no part of this publication may be reproduced or utilized in any form or by any means, electronic or mechanical, including photocopying and microfilm, without permission in writing from either ISO at the address below or ISO's member body in the country of the requester.

ISO copyright office
Case postale 56 • CH-1211 Geneva 20
Tel. + 41 22 749 01 11
Fax + 41 22 749 09 47
E-mail copyright@iso.org
Web www.iso.org

Published in Switzerland

Contents

Page

Foreword	iv
Introduction.....	v
1 Scope	1
2 Normative references	1
3 Terms and definitions	2
3.1 General definitions	2
3.2 Acoustical definitions	3
3.3 Aerodynamic definitions.....	3
4 Limitations of measurement	5
5 Design and performance requirements for test plenum	5
5.1 General	5
5.2 Test plenum: Main assembly	6
5.3 Mounting panel assembly	6
5.4 Adjustable exit port assembly	7
5.5 Insertion loss of test plenum	7
5.6 Instrumentation for static pressure measurement	7
6 Installation.....	8
6.1 Installation of test plenum in test room	8
6.2 Direction of airflow	8
6.3 Mounting of air-moving device	8
7 Operation of air-moving device	8
7.1 Input power	8
7.2 Points of operation (AC and DC air-moving devices).....	9
8 Measurement procedures.....	10
8.1 General	10
8.2 Microphone positions for measurements in an essentially free field over a reflecting plane	10
8.3 Preparations for measurements	11
8.4 Operational test of air-moving device	11
9 Measurement uncertainty.....	12
10 Information to be recorded.....	12
11 Information to be reported.....	13
Annex A (normative) Micro-fan p-q curve measurement method	23
Annex B (informative) Effects of air density	25
Annex C (informative) Data formats for presentation	26
Annex D (informative) Air-moving device acoustical noise specification	30
Annex E (informative) Guidance on the development of information on measurement uncertainty.....	31
Bibliography.....	37

Foreword

ISO (the International Organization for Standardization) is a worldwide federation of national standards bodies (ISO member bodies). The work of preparing International Standards is normally carried out through ISO technical committees. Each member body interested in a subject for which a technical committee has been established has the right to be represented on that committee. International organizations, governmental and non-governmental, in liaison with ISO, also take part in the work. ISO collaborates closely with the International Electrotechnical Commission (IEC) on all matters of electrotechnical standardization.

International Standards are drafted in accordance with the rules given in the ISO/IEC Directives, Part 2.

The main task of technical committees is to prepare International Standards. Draft International Standards adopted by the technical committees are circulated to the member bodies for voting. Publication as an International Standard requires approval by at least 75 % of the member bodies casting a vote.

Attention is drawn to the possibility that some of the elements of this document may be the subject of patent rights. ISO shall not be held responsible for identifying any or all such patent rights.

ISO 10302-1 was prepared by Technical Committee ISO/TC 43, *Acoustics*, Subcommittee SC 1, *Noise*.

This first edition of ISO 10302-1 cancels and replaces ISO 10302:1996.

ISO 10302 consists of the following parts, under the general title *Acoustics — Measurement of airborne noise emitted and structure-borne vibration induced by small air-moving devices*:

- *Part 1: Airborne noise measurement*
- *Part 2: Structure-borne vibration measurements*

Introduction

This part of ISO 10302 specifies in detail methods for determining and reporting the airborne noise emissions of small air-moving devices (AMDs) used primarily for cooling electronic equipment, such as that for information technology and telecommunications.

To provide compatibility with measurements of acoustical noise emitted by such equipment, this part of ISO 10302 uses the noise emission descriptors and sound power measurement methods of ISO 7779. The descriptor of overall airborne noise emission of the AMD under test is the A-weighted sound power level. The one-third-octave-band sound power level is the detailed descriptor of the noise emission. Octave-band sound power levels may be provided in addition to the one-third-octave-band sound power levels.

Acoustics — Measurement of airborne noise emitted and structure-borne vibration induced by small air-moving devices —

Part 1: Airborne noise measurement

1 Scope

This part of ISO 10302 specifies methods for measuring the airborne noise emitted by small air-moving devices (AMDs), such as those used for cooling electronic, electrical, and mechanical equipment where the sound power level of the AMD is of interest.

Examples of these AMDs include propeller fans, tube-axial fans, vane-axial fans, centrifugal fans, motorized impellers, and their variations.

This part of ISO 10302 describes the test apparatus and methods for determining the airborne noise emitted by small AMDs as a function of the volume flow rate and the fan static pressure developed by the AMD on the test apparatus. It is intended for use by AMD manufacturers, by manufacturers who use AMDs for cooling electronic equipment and similar applications, and by testing laboratories. It provides a method for AMD manufacturers, equipment manufacturers and testing laboratories to obtain comparable results. Results of measurements made in accordance with this part of ISO 10302 are expected to be used for engineering information and performance verification, and the methods can be cited in purchase specifications and contracts between buyers and sellers. The ultimate purpose of the measurements is to provide data to assist the designers of electronic, electrical or mechanical equipment which contains one or more AMDs.

Based on experimental data, a method is given for calculating the maximum volume flow rate of the scaled plenum up to which this part of ISO 10302 is applicable.

2 Normative references

The following referenced documents are indispensable for the application of this document. For dated references, only the edition cited applies. For undated references, the latest edition of the referenced document (including any amendments) applies.

ISO 3741, *Acoustics — Determination of sound power levels and sound energy levels of noise sources using sound pressure — Precision methods for reverberation test rooms*

ISO 3744, *Acoustics — Determination of sound power levels and sound energy levels of noise sources using sound pressure — Engineering methods for an essentially free field over a reflecting plane*

ISO 3745, *Acoustics — Determination of sound power levels and sound energy levels of noise sources using sound pressure — Precision methods for anechoic test rooms and hemi-anechoic test rooms¹⁾*

1) To be published. (Revision of ISO 3745:2003.)

ISO 5801:2007, *Industrial fans — Performance testing using standardized airways*

ISO 7779:2010, *Acoustics — Measurement of airborne noise emitted by information technology and telecommunications equipment*

ISO/IEC Guide 98-3, *Uncertainty of measurement — Part 3: Guide to the expression of uncertainty in measurement (GUM:1995)*

ANSI/ASA S2.32, *Methods for the experimental determination of mechanical mobility — Part 2: Measurements using single-point translational excitation*

JBMS 72:2003, *Acoustics — Method for the measurement of airborne noise emitted by micro-fans*

3 Terms and definitions

For the purposes of this document, the terms and definitions given in ISO 7779 and the following apply.

3.1 General definitions

3.1.1

air-moving device

AMD

fan

device for moving air which utilizes a rotating impeller driven by an electric motor with electronic or mechanical command

NOTE 1 An air-moving device has at least one inlet opening and at least one outlet opening. The openings can have elements for connection to ductwork or to other parts of the airflow path.

NOTE 2 Tests can be run with a particular frame, motor, and rotor, but with different accessories (e.g. finger guards). For the purposes of this part of ISO 10302, each such configuration is referred to as an air-moving device.

NOTE 3 Within some industries, including information technology, the unmodified term “fan” means “axial flow air-moving device”, and the unmodified term “blower” means “centrifugal air-moving device”. In this part of ISO 10302, the term “fan” is used to mean “air-moving device” and does not necessarily imply axial flow. Modifiers (such as axial, centrifugal or mixed flow) are added as necessary to distinguish between types.

3.1.2

micro-fan

air-moving device which has a maximum volume flow rate less than or equal to 0,015 m³/s

NOTE 1 Micro-fans are a subset of fans under test according to this part of ISO 10302.

NOTE 2 ISO 5801:2007, 22.4.2, Table 4 limits the range of applicability to Reynolds numbers of 12 000 or higher. This Reynolds number corresponds to the lower limit of volume flow rate of approximately 0,01 m³/s. Since lower volume fans are of interest for many cooling applications, the methodology of JBMS-72:2003, Annex A is used to measure the *p-q* curve of a micro-fan.

3.2 Acoustical definitions

3.2.1 sound power level

L_W

ten times the logarithm to the base 10 of the ratio of the sound power, P , to a reference value, P_0 , expressed in decibels

$$L_W = 10 \lg \frac{P}{P_0} \text{ dB} \quad (1)$$

where the reference value, P_0 , is 1 pW

NOTE If a specific frequency weighting as specified in IEC 61672-1^[6] and/or specific frequency bands are applied, this should be indicated by appropriate subscripts; e.g. L_{WA} denotes the A-weighted sound power level.

3.2.2 frequency range of interest

range extending from the 100 Hz one-third-octave band to the 10 kHz one-third-octave band

NOTE 1 The centre frequencies of these one-third-octave bands are defined in ISO 266^[1].

NOTE 2 For small, low-noise fans to be measured (i.e. micro-fans), depending on the size of applicable plenum, the radius of the test hemisphere may be reduced to less than 1 m, but not less than 0,5 m (see 8.2.1). However, a radius less than 1 m could itself impose limits on the frequency range over which tests are performed. For details, reference is made to ISO 7779:2010, B.1.

3.2.3 insertion loss of test plenum

ΔL

sound power level difference due to the presence of test plenum, defined as follows:

$$\Delta L = L_{W,\text{out}} - L_{W,\text{in}} \quad (2)$$

where

$L_{W,\text{out}}$ is the sound power level of a sound source determined when installed outside the test plenum;

$L_{W,\text{in}}$ is the sound power level of a sound source determined when installed inside the test plenum

NOTE The insertion loss of the test plenum is expressed in decibels.

3.3 Aerodynamic definitions

3.3.1 test plenum

structure on to which the air-moving device under test is mounted for acoustical noise emission measurements

NOTE The plenum provides a flow resistance to the air-moving device, but permits sound from the air-moving device to radiate freely into the test room with only minimal attenuation. Thus, the sound power radiated by the air-moving device can be determined from acoustical measurements made outside the test plenum.

3.3.2

air-moving device aerodynamic performance curve

“*p-q* curve”

presentation of fan static pressure as a function of volume flow rate under standard air conditions and constant operating voltage and frequency

NOTE 1 For the purpose of this part of ISO 10302, a qualifier, “aerodynamic”, before “performance curve” is inserted to distinguish from acoustical noise emission characteristics against volume flow rate.

NOTE 2 The presentation is derived in accordance with ISO 5801 or Annex A, which complement each other. The method for small air-moving devices of volume flow rate up to 0,015 m³/s is specified in Annex A.

NOTE 3 For convenience, in this part of ISO 10302, the term “*p-q* curve” is used.

3.3.3

point of operation

point on the air-moving device aerodynamic performance curve corresponding to a particular volume flow rate

NOTE The point of operation is controlled during a test by adjusting the “slider” on the test plenum exit port assembly.

3.3.4

overall static efficiency of air-moving device

$\eta_{0,s}$

volume flow rate multiplied by the fan static pressure and divided by the input electrical power

NOTE 1 The overall static efficiency, $\eta_{0,s}$, expressed as a percentage, is given by

$$\eta_{0,s} = \frac{P_{s,f} q_V}{P_{\text{input}}} \times 100 \quad (3)$$

where

$p_{s,f}$ is the fan static pressure, in pascals;

q_V is the volume flow rate, in cubic metres per second;

P_{input} is the motor input power, in watts (true power, not including reactive component), supplied at the terminals of the electric drive motor.

NOTE 2 The air-moving device is defined to include the motor, impeller and frame; therefore, the overall static efficiency includes both the electromechanical efficiency of the motor and the aerodynamic efficiency of the impeller and frame.

3.3.5

standard air density

density under standard air conditions

NOTE The value is 1,20 kg/m³.

3.3.6

standard air conditions (for aerodynamic performance measurement)

specified meteorological conditions

NOTE For the purposes of this part of ISO 10302, the conditions are: 20 °C temperature; 50 % relative humidity; and 1,013 × 10⁵ Pa ambient pressure.

4 Limitations of measurement

Experimental data show that this method is useful up to the maximum volume flow rate, $q_{V,\max}$, as a function of nominal air volume, V , of the plenum used and up to a fan static pressure of 750 Pa.

$$q_{V,\max} = \frac{q_{V,0}}{V_0} V \quad (4)$$

where

$q_{V,\max}$ is the maximum volume flow rate of the scaled plenum, in cubic metres per second;

$q_{V,0}$ is the maximum volume flow rate of the full-size plenum, in cubic metres per second,
 $q_{V,0} = 1 \text{ m}^3/\text{s}$;

V_0 is the nominal air volume of the full-size plenum defined in Clause 6, in cubic metres, $V_0 = 1,3 \text{ m}^3$;

V is the nominal air volume of the scaled plenum, in cubic metres.

NOTE 1 The value of the interior air volume of a full-size plenum of $1,3 \text{ m}^3$ is rounded up from $1,296 \text{ m}^3 = 1,2 \text{ m}$ (width) \times $1,2 \text{ m}$ (depth) \times $0,9 \text{ m}$ (height).

NOTE 2 It is noted that the “nominal air volume” means approximate air volume calculated from the outer dimensions of the plenum. For instance, in case of 1/4 sized plenum, the nominal air volume of the plenum, excluding the leg height, becomes $V = blh = 0,3 \text{ m} \times 0,3 \text{ m} \times 0,225 \text{ m} = 0,020 25 \text{ m}^3$, where b is width, l is depth, and h is height.

For the purposes of this part of ISO 10302, it is recommended that the smallest plenum possible be applied, provided that the maximum volume flow rate of the fan is within the limit of Equation (4).

The method defined in this part of ISO 10302, by reference to ISO 7779, provides for determination of sound power levels in a qualified environment, using either a comparison method in a reverberation test room based on ISO 3741, or a direct method in essentially free-field conditions over a reflecting plane based on ISO 3744 or ISO 3745. The method specified in this part of ISO 10302 may be applied to air-moving devices (AMDs) which radiate: a) broad-band noise; b) narrow-band noise; or c) noise that contains discrete frequency components.

The method specified in this part of ISO 10302 permits the determination of acoustical noise emission levels for an individual unit under test. If these levels are determined for several units of the same production series, the results may be used to determine a statistical value for the production series.

CAUTION — Vibration, flow disturbances, insertion loss and other phenomena may alter radiated sound power in the actual application; therefore, the results of measurements made in accordance with this part of ISO 10302 may differ from the results obtained when AMDs are installed in equipment.

NOTE 3 This part of ISO 10302 does not describe measurement of the structure-borne noise generated by AMDs.

5 Design and performance requirements for test plenum

5.1 General

The design specified is intended to meet the limits stated for maximum volume flow rate and maximum fan static pressure. The design provides an acoustically transparent, adjustable flow resistance to the AMD.

NOTE 1 See 5.5 for requirements for confirming acoustical transparency in accordance with this part of ISO 10302.

The reference design of the plenum is specified in 5.2 to 5.6 and shown in Figures 1 to 8. Also addressed in these subclauses and elsewhere in this part of ISO 10302 are permitted variations from this design, primarily the option of reducing the linear dimensions of the frame and some dimensions of other parts, while maintaining geometric proportions, in the range from full to quarter scale. Such a reduction reduces the maximum permitted volume flow rate of AMDs to be tested in direct proportion to the reduction in volume of the plenum [see Equation (4)], i.e. by the linear scale raised to the third power.

NOTE 2 These variations can better accommodate the use of smaller or quieter fans as well as test chambers with doors too narrow for the reference design plenum.

Permitted variations have been shown to yield standard deviations of reproducibility within the range of Table 1. The degree to which other deviations from the reference design affect the uncertainty of the determination of sound power levels of AMDs is not known.

5.2 Test plenum: main assembly

5.2.1 General: The test plenum shall consist of an airtight chamber constructed with a frame covered with an airtight acoustically transparent polyester film, a mounting panel, and an adjustable exit port assembly as shown in Figure 1.

The plenum shall conform to the requirements specified in 5.2.2 to 5.2.7.

5.2.2 Plenum size: Figure 1 shows the dimensions of the full-size plenum.

5.2.3 Covering: Isotropic polyester film of nominal thickness 25 µm to 50 µm. Batten strips may be used to protect the covering (see Figures 1 and 2).

5.2.4 Frame: Suitable material with nominal size of 50 mm × 50 mm that provides structural integrity for the plenum. Corner gussets are recommended for wood framing and may be needed for other materials (see Figure 3). Frame linear dimensions including the thickness of the framing members shall be in scale with the plenum size.

5.2.5 Frame material: Experience has shown that either a hardwood, such as birch, or aluminium tubing provides sufficient strength, stiffness and durability and complies with the acoustical performance requirements outlined in 5.5.

5.2.6 Vibration isolation: The test plenum feet or support should provide vibration isolation of the plenum from the floor, for any size of plenum. The intent is to break the vibration-transmission path between the plenum and the floor. Whichever method is chosen, the 0,1 m overall leg height should be maintained for the full-size plenum (see Figures 1 and 3). The 0,1 m leg height shall be in scale with the plenum size.

5.2.7 Taps for fan static pressure: The pressure ring shall be mounted immediately behind the mounting panel. The ring should be sized to match the perimeter of the mounting panel (see Figure 4). The perimeter dimensions of the pressure ring shall be in scale with the plenum size. The tubing diameter and taps do not scale, but remain constant.

5.3 Mounting panel assembly

The mounting panel assembly shall comprise some kind of adapter plate sealed and attached to a reinforced rubber sheet which, in turn, is sealed and attached to the test plenum frame through the use of aluminium retaining strips (see Figures 1, 4, and 5). The adapter plate is used to mount the fan securely to the rubber panel. It may take the form of that shown in Figure 5, which is well suited to axial-flow fans, or some other form more suitable to the particular air-moving device under test. The adapter plate should not cause any disturbance to the air flow and should not cause any additional sound radiation other than that from the air-moving device itself.

The mounting panel assembly (comprising adapter plate and flexible panel) may be replaced by a single damped plate with comparable cut-outs (but no adapter plate) of specified material without significantly affecting the airborne sound measurements.

The specification on the plate stock is mobility level (reference: 1 m/N s) of -45 dB from 25 Hz to 5 000 Hz when measured in the middle of a plate of dimension 1,0 m² with no fan-mounting hole and with the plate freely suspended by two corners. The mobility level measurement shall be made in accordance with ANSI/ASA S2.32.

The tolerance on mobility levels is ± 8 dB from 25 Hz to 100 Hz, ± 4 dB from 100 Hz to 200 Hz and ± 2 dB from 200 Hz to 5 000 Hz. These tolerance limits ensure that the plate has sufficient damping to prevent excitation of the frame. Such replacement panels are sometimes used in connection with fan vibration measurements (which are addressed in ISO 10302-2). Using the same mounting panel for sound and vibration measurements may improve the efficiency of combined tests. If the reference design mounting panel is replaced, on the basis of impedance testing of the plate material, this shall be stated in the test report.

The opening of the adapter plate shall conform to the recommendations of the AMD manufacturer. The openings in the clamp frame and rubber panel shall be larger than the opening in the adapter plate to minimize disturbance of the airflow. The length, width, and thickness of the aluminium retainer strip as well as the length and width of the reinforced rubber mounting panel shall be in scale with the plenum size. The other dimensions, including the panel thickness, do not scale.

5.4 Adjustable exit port assembly

The adjustable exit port assembly shall comprise a fixed aperture plate and a slider (movable sliding plate) to provide a continuously variable exit port of area from 0,0 m² to 0,2 m² for the full-size plenum (see Figures 6 to 8). The exit port maximum area shall be in scale with the square of the linear scale of the plenum.

NOTE The point of operation of the AMD is controlled during a test by adjusting the position of the slider on the exit port assembly.

5.5 Insertion loss of test plenum

For the purpose of this part of ISO 10302, adequacy of the test plenum is evaluated by means of insertion loss of the test plenum (3.2.3).

The one-third-octave-band insertion loss of the test plenum shall be not greater than (0^{+3}_{-2}) dB and is recommended to be not greater than $(0 \pm 1,5)$ dB, when determined in accordance with the procedure specified in steps a) to c).

- a) The sound power levels of a sound source (e.g. a loudspeaker) shall be determined twice: once with the source inside the test plenum and once with the source outside the plenum, but at the same location in the test room. If insertion loss measurements are made in a free field over a reflecting plane, the hemispherical microphone array should be centred on the sound power source.
- b) Measurement uncertainties can arise if the loudspeaker sound power source is moved relative to reflective surfaces (floor and mounting panel) between the two sound power determinations. Accordingly, install the sound power source on the floor. Remove the mounting panel and rotate the plenum by 90° so that the face normally covered by the mounting panel is parallel to the floor and the exit port is on the top surface. The plenum can then be lowered or raised vertically to cover or expose the sound power source without causing movement of the source.
- c) The source shall be mounted to ensure that solid body radiation from the sound power source which is transmitted into the test plenum frame or covering is minimized.

The exit port slider shall be closed during the insertion loss test.

5.6 Instrumentation for static pressure measurement

The fan static pressure developed inside the test plenum by the AMD shall be measured using a pressure ring (shown in Figure 4). This pressure ring has four taps spaced 90° apart as shown, facing towards the centre of the discharge of the AMD (in the plane of the ring). The pressure ring should be mounted on the frame that supports the mounting panel. A pressure line can be brought out of the box by drilling a small, smooth, burr-free hole through the frame. The fan static pressure should be read on a calibrated pressure meter.

The manometer or other pressure measuring device used shall have a resolution of 1 % or finer (e.g. 0,5 %) of maximum fan static pressure.

Manometers shall have an uncertainty under conditions of steady pressure, not exceeding ± 1 % of the point of best efficiency on aerodynamic performance curve of AMD of interest, or 1,5 Pa, whichever is greater. For more details, see ISO 5801:2007, 6.2.

6 Installation

6.1 Installation of test plenum in test room

The test plenum shall be installed on the floor of a test room which has been qualified for sound power level determinations in accordance with ISO 7779:2010, Clause 6 or Clause 7, respectively.

6.2 Direction of airflow

The AMD should preferably be tested when discharging into the test plenum. Exceptions to this airflow direction may be made to avoid undesirable flow conditions. For example, centrifugal fans or motorized impellers without scrolls may be tested with the plenum on the inlet.

6.3 Mounting of air-moving device

The AMD shall be mounted on and sealed to the mounting panel assembly specified in 5.3 (either the rubber sheet with adapter plate and clamp frame or the single damped panel). Additional vibration-isolated supports which shall not interfere with the propagation of airborne sound shall be provided as necessary to maintain the mounting plane parallel with the face of the test plenum; in particular, such supports may be required when testing centrifugal fans, especially at low static pressures. In all cases, the mounting panel assembly shall remain plane with the face of the plenum. For large AMDs, auxiliary support may be required to prevent the weight of the device from bending or twisting the mounting panel. Such auxiliary support shall not interfere with the propagation of airborne sound and shall be vibration-isolated from the air-moving device.

The AMD should be tested for each of its configurations (see Note 2 to 3.1.1).

In some cases, AMDs operating under conditions which keep the plenum exit port completely open can cause the polyester film panels to flutter or vibrate, creating unwanted noise. In such cases, steps should be taken to minimize noise due to fluttering or vibration. For example, the mounting panel assembly with the AMD can be detached from the rest of the plenum and the latter moved out of the way. The mounting panel assembly should be maintained planar and suspended above the floor of the test room at the same location as specified in 6.1.

7 Operation of air-moving device

7.1 Input power

7.1.1 Alternating current (AC) air-moving devices

The AMD shall be operated at each rated power line frequency, and within $\pm 1,0$ % of either:

- a) the rated voltage (if any is stated); or
- b) the mean voltage of a stated voltage range (e.g. 220 V for a stated range of 210 V to 230 V).

For power having more than two phases, phase-to-phase voltage variations shall not exceed 1 % of the rated voltage.

NOTE Though the test procedure of Clause 7 is similar to those of ISO 7779, the tolerance of voltage given here is much tighter than that in ISO 7779 (i.e. 5 % of the rated voltage).

7.1.2 Direct current (DC) air-moving devices

The AMD shall be operated within ± 1 % of the rated nominal voltage.

Additional tests may be run at other voltages (e.g. rated maximum, rated minimum).

7.2 Points of operation (AC and DC air-moving devices)

7.2.1 Required points of operation

The AMD shall be tested at three points of operation for each of the required line frequencies and voltages given in 7.1. These points of operation correspond to:

- a) the adjustable exit port (slider) completely open;
- b) 80 % of maximum volume flow rate on the p - q curve;
- c) 20 % of maximum volume flow rate on the p - q curve.

The actual static pressure reading at each point of operation shall be recorded.

NOTE 1 In this part of ISO 10302, p - q curve measurement is a prerequisite for acoustical noise measurement. So the "maximum volume flow rate" means the point on the p - q curve, which corresponds to the condition of static pressure equal to 0. For instance, when the maximum volume flow rate of a fan under test is read as 0,01 m³/s from the p - q curve, 80 % of maximum volume flow rate means 0,01 m³/s \times 0,8 = 0,008 m³/s.

NOTE 2 Within the framework of this part of ISO 10302, a clear distinction is made between "slider completely open" and "maximum flow rate". In ISO 10302:1996 and other conventional standards this was not the case. Condition a), "slider completely open", was referred to as the "maximum flow rate" or "free delivery" condition. However, air-flow resistance by the plenum influences the actual point of operation. For example, the three smooth lines near the abscissa in Figure 9 indicate the system impedance curves of the quarter-scale, half-scale and full-scale plenum respectively, with slider completely open.

7.2.2 Additional points of operation

Additional tests may be run at other points of operation, including the point of maximum overall static efficiency, to establish the sound power level versus volume flow rate curve. Some AMDs (e.g. small tube-axial fans) may be unstable when operated near the maximum overall static efficiency point. Tests should not be conducted at unstable points of operation.

7.2.3 Procedure

Points of operation shall be established as in steps a) to c).

- a) The fan static pressure at the designated percentage volume flow rates (see 7.2.1) shall be read from the AMD aerodynamic performance curve (p - q curve) determined (prior to acoustical noise measurement) in accordance with ISO 5801 or Annex A, as applicable, with the same direction of airflow.
- b) If the ambient atmospheric density during the noise test differs by more than 1 % from that recorded in accordance with ISO 5801 or Annex A, as applicable, the fan static pressure shall be corrected as follows:

$$p_{s,2} = p_{s,1} \left(\frac{273 + t_1}{273 + t_2} \right) \frac{p_{amb,2}}{p_{amb,1}} \quad (5)$$

where

$p_{s,2}$ is the fan static pressure to be set on the test plenum, in pascals;

t_2 is the air-flow temperature during acoustical noise measurement, in degrees Celsius;

$p_{amb,2}$ is the atmospheric pressure during acoustical noise measurement, in kilopascals;

- $p_{s,1}$ is the fan static pressure during volume flow rate measurement, in pascals;
- t_1 is the air-flow temperature during volume flow rate measurement, in degree Celsius;
- $p_{amb,1}$ is the atmospheric pressure during volume flow rate measurement, in kilopascals.

- c) The slider shall be adjusted to obtain a reading of the fan static pressure, $p_{s,2}$, within $\pm 1\%$ of the maximum fan static pressure, determined with a pressure-measuring instrument satisfying the requirements of 5.6.

The fan and the fan static pressure shall be allowed to stabilize at each point of operation.

If measurements are made at the maximum overall static efficiency point, care should be taken when adjusting the plenum for this point of operation. Some AMDs have three or more values of volume flow rate corresponding to the same fan static pressure in the region of maximum overall static efficiency. Only the point with the highest volume flow rate is the maximum overall static efficiency point. To obtain this point of operation, start from free delivery and increase the static pressure until the point of operation is reached.

If an AMD is unstable (e.g. unsteady speed or pressure) at one of the recommended points of operation, decrease the fan static pressure until stability is achieved and use the new point of operation thus reached. The instability shall be reported and the alternative point of operation shall be described.

NOTE The AMD aerodynamic performance curve obtained according to ISO 5801 or Annex A can differ from the performance on the test plenum. This difference is assumed to be equivalent to that typical of normal AMD applications, and no corrections for test plenum differences are necessary.

8 Measurement procedures

8.1 General

Sound power levels shall be determined in accordance with ISO 7779. ISO 7779:2010, Clause 6 permits the use of a comparison method in a reverberation test room, based on ISO 3741. ISO 7779:2010, Clause 7 permits sound power determination in an essentially free field over a reflecting plane based on ISO 3744 and ISO 3745. If a method specified in ISO 7779:2010, Clause 7 is used, one of the sets of microphone positions described in 8.2 is required.

NOTE When using the method of ISO 7779:2010, Clause 7, sound power levels can be influenced by air density. This part of ISO 10302 follows ISO 7779:2010 for the corrections. For some cases requiring consideration of the influence of air density, Annex B gives supplementary information.

8.2 Microphone positions for measurements in an essentially free field over a reflecting plane

8.2.1 General

For the purposes of this part of ISO 10302, the measurement surfaces for determining sound power level are hemispherical, selected from those specified in ISO 3744 and ISO 3745. The radius shall not be smaller than 0,5 m (see Note 2 to 3.2.2).

NOTE 1 In ISO 7779, measurement surfaces in forms other than hemispherical are specified for an essentially free field over a reflecting plane. However, for the purpose of sound power level determination using the test plenum mounted in such an acoustical environment, this part of ISO 10302 permits only hemispherical measurement surfaces.

One of the sets of microphone positions in either 8.2.2 or 8.2.3 should be used, but the radius shall not be smaller than 0,5 m (see Note 2 to 3.2.2). In any case, the origin of the co-ordinates is located at the vertical projection of the centre of the mounting opening on the reflecting plane. If a test plenum geometrically smaller than that in Figure 1 is used, a radius of between 2 m and the geometrically scaled radius shall be used.

NOTE 2 These sets of microphone positions reduce interference effects caused by reflections from the plane and can avoid intake or exhaust air streams.

8.2.2 Fixed points on a hemisphere

The locations of 10 positions associated with equal areas on the surface of the hemisphere are numbered from 1 to 10 in Figure 10. The co-ordinates (x, y, z) are given in Table 2 and Figure 10.

NOTE For convenience, Table 2 and Figure 10 show co-ordinates of fixed positions on the hemispherical measurement surface.

8.2.3 Coaxial circular paths in five or more parallel planes

Instead of fixed positions, circular paths consisting of coaxial circular paths according to ISO 3744 may be used. See Figure 11.

8.3 Preparations for measurements

Steps a) to g) shall be taken in preparation for noise emission measurements on each AMD.

- a) Record the name, model number, serial number, dimensions, nameplate data and complete description of the AMD under test.
- b) Obtain the AMD aerodynamic performance curve in accordance with ISO 5801 or Annex A, as applicable.
- c) Check the calibration of the microphone(s) in conformity with ISO 7779:2010.
- d) Measure the background noise levels in the test room in conformity with ISO 7779:2010.
- e) Measure the ambient temperature, relative humidity, and ambient pressure.
- f) If a method requiring the use of a reference sound source (RSS) is to be used, measure the sound pressure levels produced by the RSS.
- g) Zero the manometer or other pressure-measuring device used for measuring the fan static pressure in the test plenum.

8.4 Operational test of air-moving device

Steps a) to h) shall be taken in carrying out the noise emission measurements on each AMD configuration.

- a) Allow the AMD under test to warm up for a sufficient period of time before proceeding with the acoustical test to allow the temperature to stabilize. If this time is unknown, the equipment shall be operated for at least 30 min before the acoustical test.
- b) Mount the AMD on the test plenum in accordance with 6.3.
- c) Adjust the voltage (and frequency when AC powered) in accordance with 7.1.
- d) Adjust the slider to obtain the desired point of operation in accordance with 7.2.
- e) Determine the sound power level in conformity with ISO 7779:2010, Clause 6 or Clause 7, as applicable. A-weighted sound power levels and one-third-octave-band sound power levels are required; octave-band sound power levels are optional.
- f) Record the data in conformity with Clause 10.
- g) Repeat steps d) to f) for each point of operation.
- h) Repeat steps c) to g) for each voltage as required.

In some tests of small centrifugal fans on a full-scale plenum, discrete tones not normally present in the spectrum of the fan appeared; these apparently coincided with plenum resonance frequencies. This phenomenon has not been widely noted, but if unexpected tones appear during testing, the possible cause should be explored.

9 Measurement uncertainty

The uncertainty of results obtained from measurements in accordance with this part of ISO 10302 shall be evaluated, preferably in compliance with ISO/IEC Guide 98-3. If reported, the expanded uncertainty together with the corresponding coverage probability as defined in ISO/IEC Guide 98-3 shall be given. Guidance on the determination of the expanded uncertainty is given in Annex E.

If, in a laboratory performing measurements in accordance with this part of ISO 10302, current knowledge is still insufficient to fully apply ISO/IEC Guide 98-3, the values given in Table 1 are recommended for provisional use in test reports.

Table 1 — Estimated values of the standard deviation of reproducibility of sound power levels of air-moving devices determined in accordance with this part of ISO 10302

Octave-band centre frequency Hz	One-third-octave-band centre frequency Hz	Standard deviation of reproducibility, σ_{R0} dB
125	100 to 160	4,0
250	200 to 315	2,5
500 to 4 000	400 to 6 300	1,5
8 000	8 000	2,5
	10 000	3,0
A-weighted		1,5

NOTE 1 For the plenum between full and half size, these estimates are based on interlaboratory comparisons (Reference [10]) on tube-axial and forward-curved centrifugal fans in the range of volume flow rate from 0,016 m³/s to 0,456 m³/s, conducted in 14 laboratories (including both reverberation and hemi-anechoic chambers) following the guidelines provided by ISO 5725:1986^[3]. For a smaller plenum, down to one-quarter size, the measurement uncertainty is assumed to be similar for the purposes of this part of ISO 10302.

NOTE 2 The standard deviation of reproducibility data given in Table 1 is assumed to reflect the cumulative effects of all sources of uncertainty in measurements in accordance with this part of ISO 10302, excluding variations in the sound power level from specimen to specimen. It does not, however, cover any systematic bias which might occur between sound power levels determined with different measurement methods.

NOTE 3 The standard deviation of repeatability for the same specimen and the same laboratory measurement conditions can be considered to be considerably smaller than the corresponding standard uncertainties on which the values in Table 1 are based.

10 Information to be recorded

The following information shall be recorded, when applicable, for all measurements made in accordance with the requirements of this part of ISO 10302.

At each point of operation, record the following data and other information required by ISO 7779:2010:

- a) actual input voltage, in volts;
- b) fan static pressure, in pascals, with data resolutions of at least $\pm 1\%$ of measured value, or 2,5 Pa, whichever is the larger;
- c) slider location or exit port open area (optional);

- d) rotational frequency, rounded to the nearest 5 min^{-1} ;
- e) input electrical power, in watts, if required;
- f) line frequency, in hertz, when AC powered;
- g) A-weighted sound power level determined in conformity with ISO 7779:2010, Clause 6 or Clause 7, as applicable, and rounded to the nearest 0,1 dB (reference: 1 pW);
- h) one-third-octave-band sound power levels (reference: 1 pW) determined in conformity with ISO 7779:2010, Clause 6 or Clause 7, as applicable, and rounded to the nearest 0,1 dB;
- i) octave-band sound power levels (reference: 1 pW) determined in conformity with ISO 7779:2010, Clause 6 or Clause 7, as applicable, and rounded to the nearest 0,1 dB (optional).

11 Information to be reported

Data should be presented using forms similar to those given in Annex D. The report shall contain at least the following information:

- a) a statement that the AMD has been tested in conformity with this part of ISO 10302 and that sound power levels have been determined in conformity with ISO 7779 (the method used for determinations of sound power levels shall be stated);
- b) manufacturer, product name (if any), manufacturer's part number, serial number (if any), dimensions (length, width, depth, hub diameter, impeller diameter), all other nameplate data, and a complete description of the AMD under test;
- c) the AMD aerodynamic performance curve, or the reference points of operation used;
- d) A-weighted sound power level, L_{WA} (reference: 1 pW), in decibels, rounded to the nearest 1,0 dB for each point of operation, corresponding to each voltage — if there is possibility of post data processing for calculation of statistical upper limit, A-weighted sound power level data of each sample shall have a resolution of 0,1 dB or finer);

NOTE For the purpose of declaring statistical values of sound power levels of AMDs, the A-weighted sound power level can be stated either in decibels rounded to the nearest 1,0 dB, or in bels rounded to the nearest 0,1 B. If statistical values are used, this should be made explicit in the report.

- e) the sound power levels, L_W , rounded to the nearest 1,0 dB (reference: 1 pW) in one-third-octave bands and, optionally, in octave bands, for each point of operation;
- f) detailed description of operating conditions of the AMD under test as recorded in accordance with Clause 9 (voltage, frequency, fan static pressure, corresponding volume flow rate, input power, and rotational frequency);
- g) temperature in degrees Celsius, relative humidity as a percentage, ambient pressure in kilopascals, and any other information that may be pertinent to the particular AMD under test;
- h) the associated expanded measurement uncertainties of A-weighted sound power levels determined according to the procedure used shall be reported (see Clause 9), with results rounded to the nearest 0,1 dB — in addition, information may be given on the basis of Annex E.

Dimensions in metres

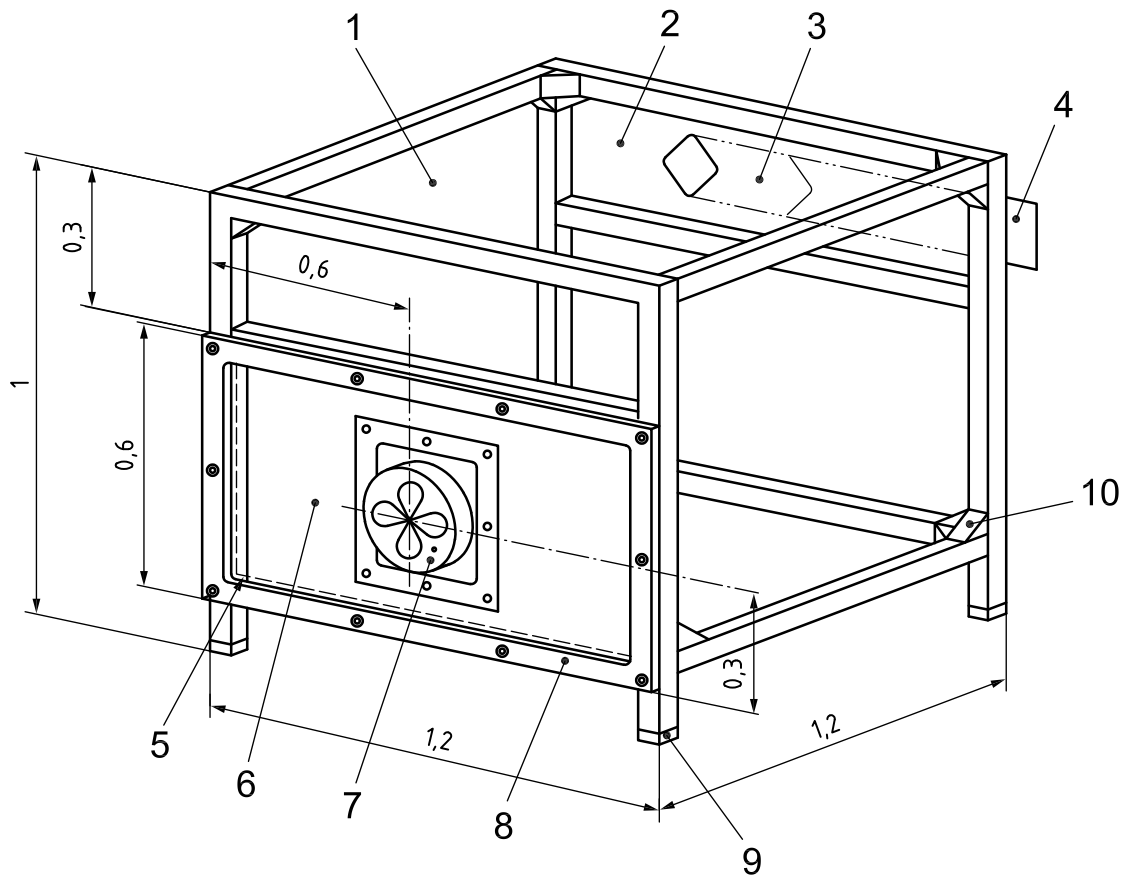

Key

- 1 polyester film (covers all areas, including bottom, except mounting panel and exit port)
- 2 adjustable exit port assembly
- 3 slider opening
- 4 slider
- 5 piezometer pressure ring behind panel
- 6 mounting panel assembly
- 7 fan
- 8 retainer
- 9 vibration isolation
- 10 gusset

Figure 1 — Test plenum (full size)

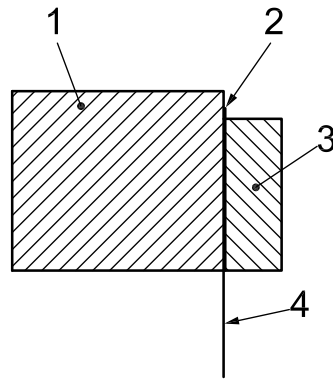

Key

- 1 frame
- 2 adhesive (holds polyester film)
- 3 external batten, screwed on (holds polyester film against adhesive)
- 4 polyester film

Figure 2 — Test plenum — Film attachment detail

Dimensions in millimetres

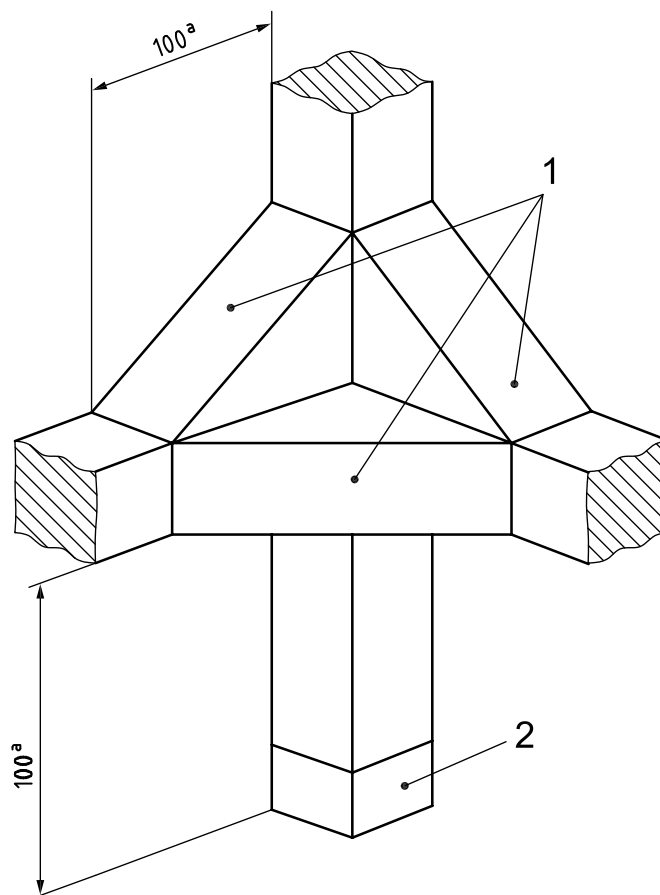

Key

- 1 braces, all corners, screwed and glued
- 2 vibration isolator (on each leg)
- ^a Typical dimension.

Figure 3 — Test plenum — Gusset and vibration isolation

Dimensions in millimetres

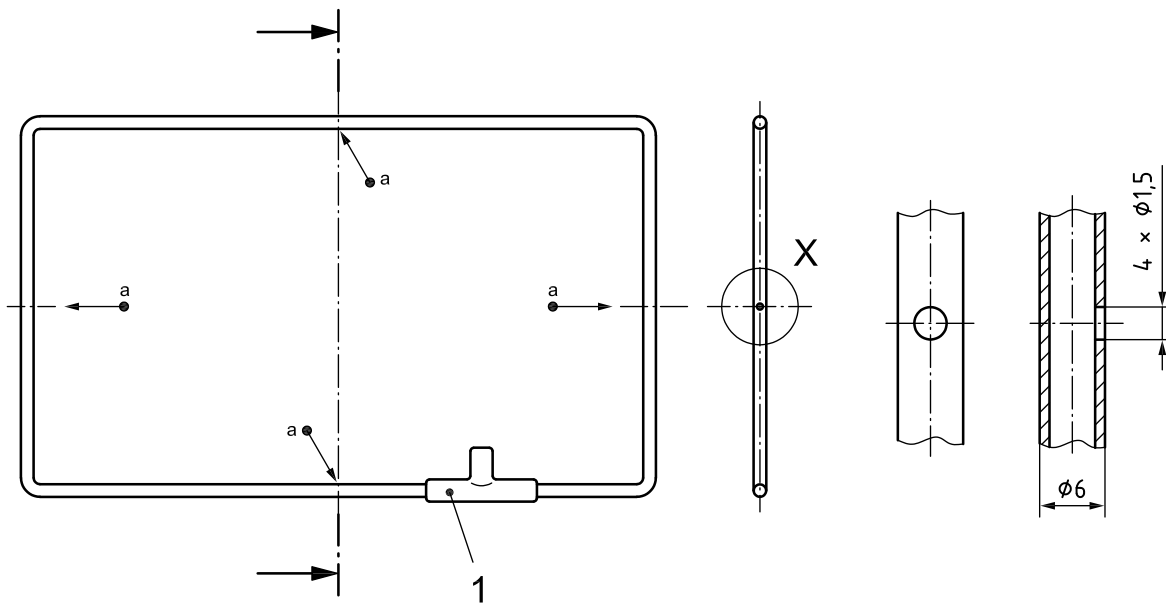

Key

1 pressure line (as required)

a Tap locations.

a) Detail

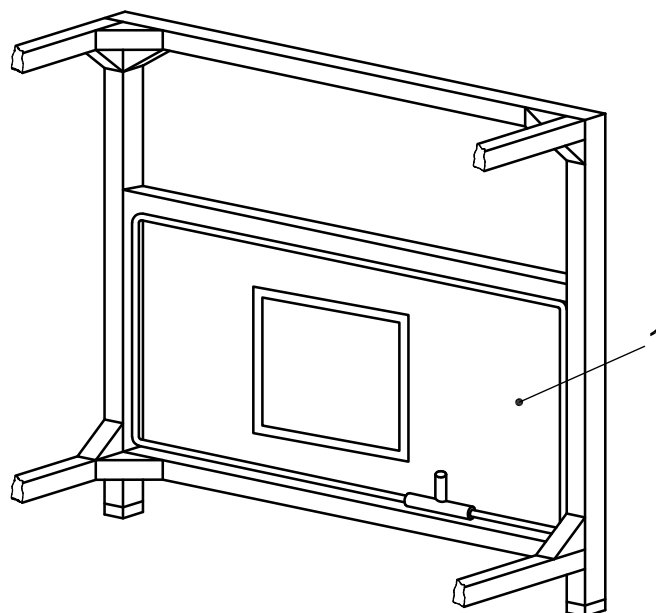

Key

1 rear mounting panel assembly

b) Location

Figure 4 — Test plenum — Pressure ring

Dimensions in millimetres

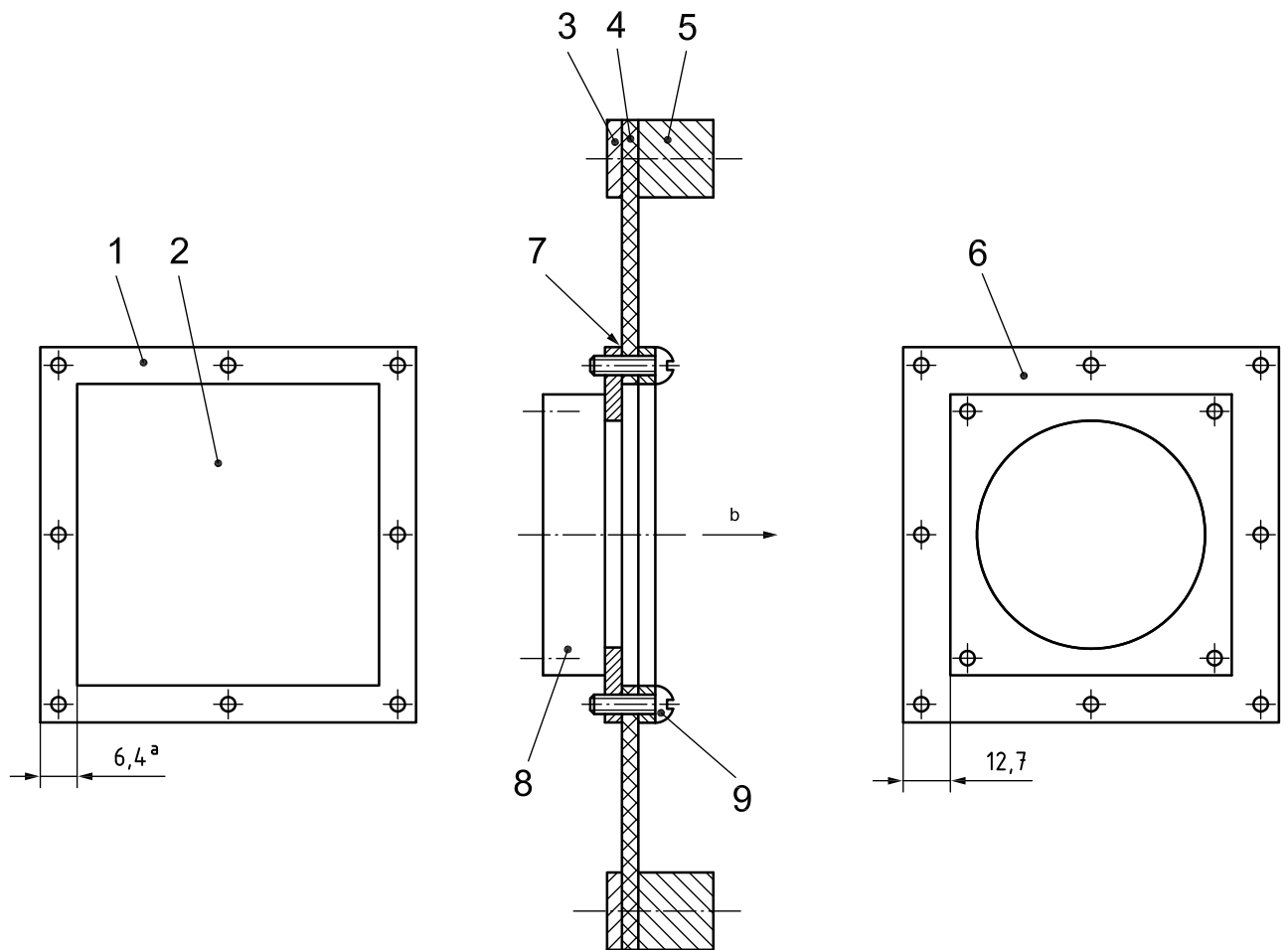

Key

- 1 clamp frame (3,2 mm thick aluminium)
- 2 cut-out
- 3 retainer aluminium strip with screw every 150 mm nom.
- 4 reinforced rubber panel, 5 kg/m² nom. loaded rubber
- 5 test plenum frame (ref.)
- 6 adapter plate (3,2 mm thick aluminium)
- 7 sealant
- 8 fan
- 9 screws or studs

^a Typical minimum.

^b Airflow.

Figure 5 — Mounting panel assembly

Dimensions in millimetres

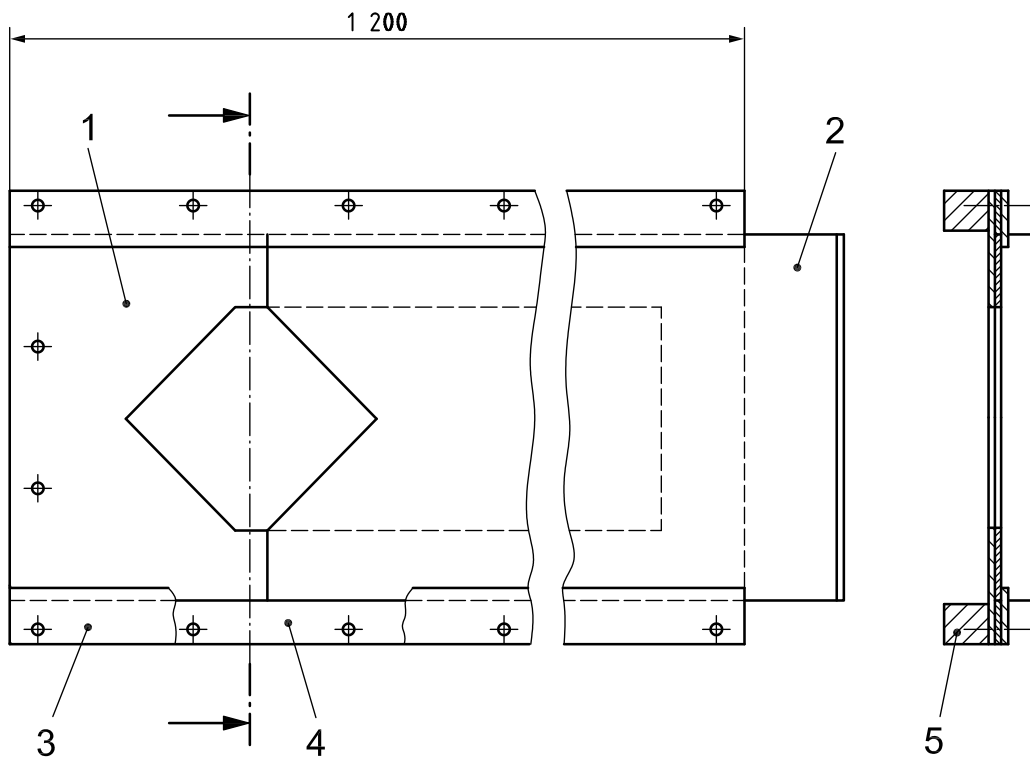

Key

- 1 aperture plate (see Figure 7)
- 2 slider (see Figure 8)
- 3 retainer (steel, 50 mm × 1,3 mm)
- 4 spacer and bearing (plastics, 30 mm × 1,6 mm)
- 5 frame (ref.)

Figure 6 — Adjustable exit port assembly

Dimensions in millimetres

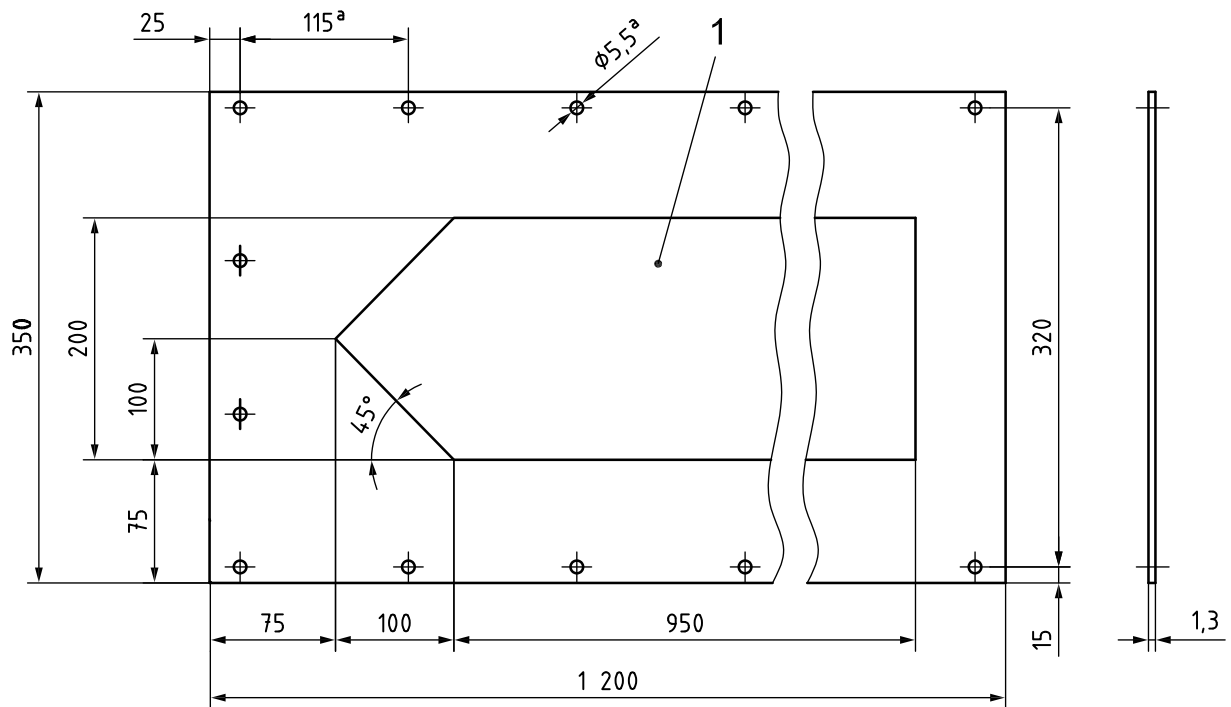

Key

- 1 cut-out
- a Typical value.

Figure 7 — Adjustable exit port assembly — Aperture plate (stainless steel)

Dimensions in millimetres

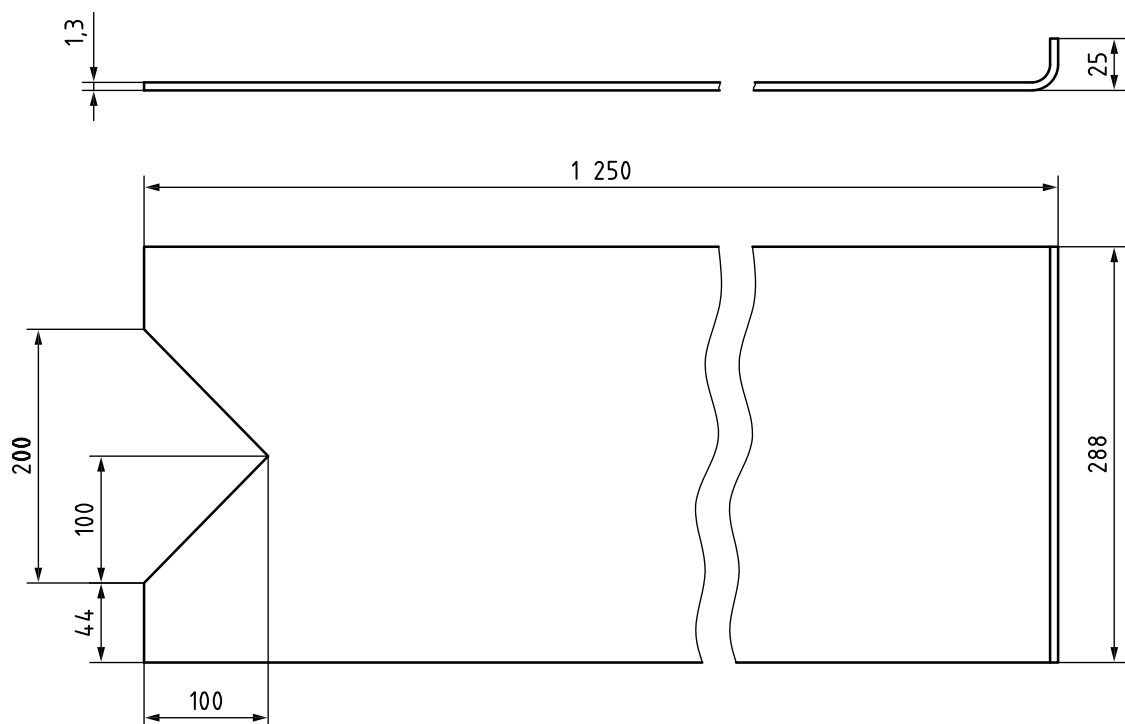
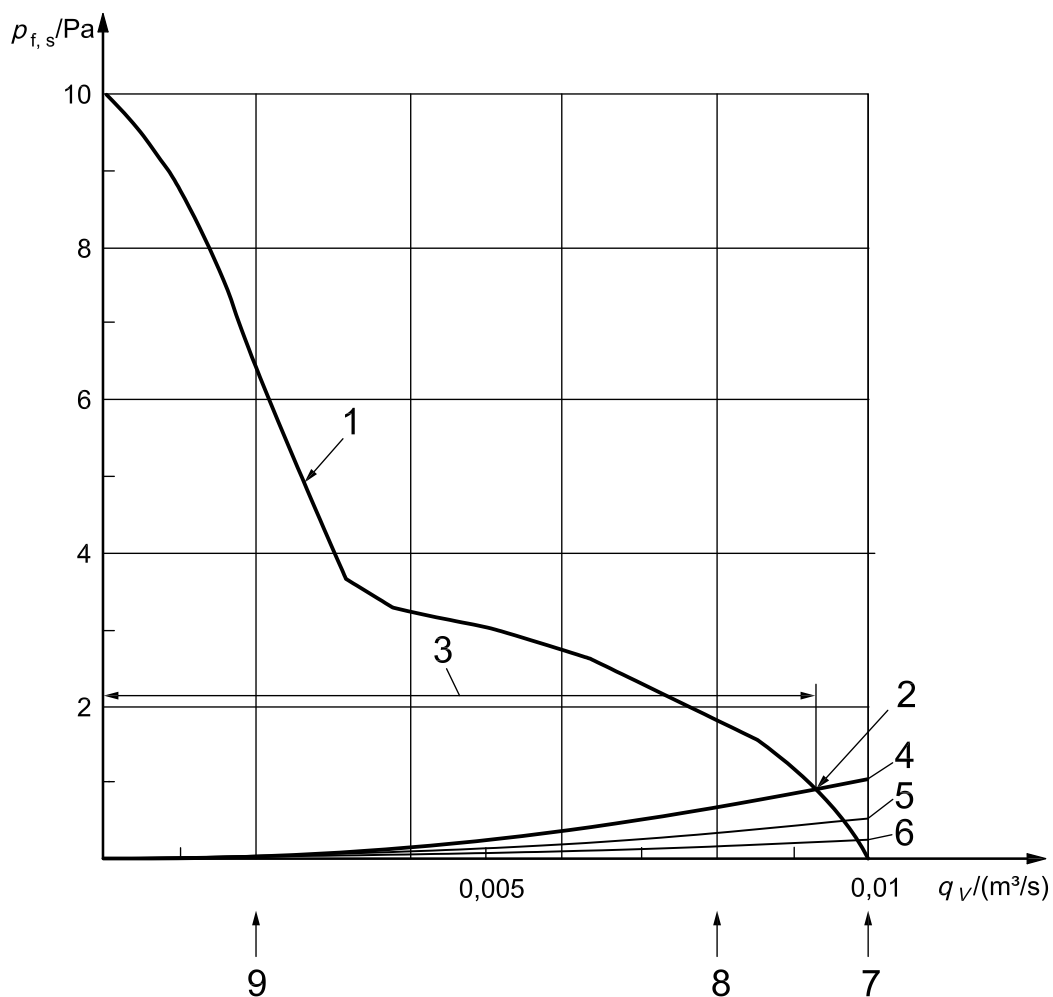

Figure 8 — Adjustable exit port assembly — Slider (stainless steel)



Key

- 1 example of p - q curve with maximum volume flow rate = 0,01 m³/s; maximum static pressure = 10 Pa
- 2 point of operation for 1/4 size plenum, which is the cross-point of the p - q curve and the system impedance curve of the plenum
- 3 adjustable region of volume flow rate by slider
- 4 quarter-size plenum
- 5 half-size plenum
- 6 full-size plenum
- 7 point of operation a) (i.e. maximum volume flow rate)
- 8 point of operation b) (i.e. 80 % of maximum volume flow rate)
- 9 point of operation c) (i.e. 20 % of maximum volume flow rate)

Figure 9 — Schematic correlation between p - q curve versus system impedance curves (not to scale)

Table 2 — Co-ordinates of hemispherical measurement surface for sources emitting discrete tones (10 measurement heights)

Measurement position No.	x/r	y/r	z/r
1	-0,16	0,96	0,22
2	-0,78	0,60	0,20
3	-0,78	-0,55	0,31
4	-0,16	-0,90	0,41
5	0,83	-0,32	0,45
6	0,83	0,40	0,38
7	0,26	0,65	0,71
8	-0,74	0,07	0,67
9	0,26	-0,50	0,83
10	-0,10	0,10	0,99

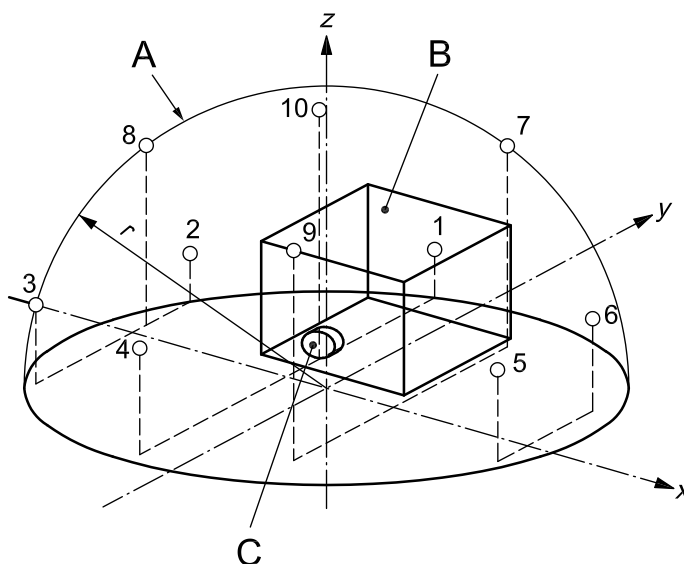

- Key**
- 1,2,3,4,5,6,7,8,9,10 microphone positions
 - A measurement surface
 - B plenum box
 - C air-moving device mounting location
 - r radius of hemisphere

Figure 10 — Hemispherical surface — 10 measurement points

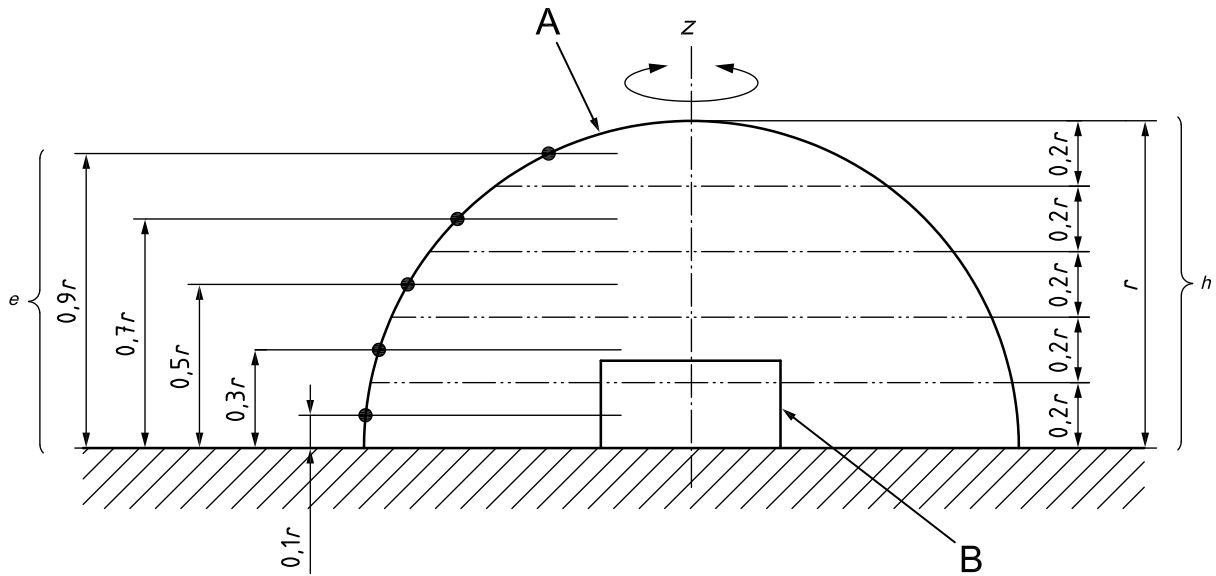

Key

- A measurement surface
- B reference box
- e elevation of microphone traverses
- h height of corresponding areas of hemisphere
- r radius of hemisphere
- z axis of rotation of microphone traversing mechanism

NOTE The paths are selected so that the annular area of the hemisphere associated with each path is the same.

Figure 11 — Coaxial circular five or more paths in parallel planes for microphone traverses in a free field over a reflecting plane

Annex A (normative)

Micro-fan p - q curve measurement method

A.1 Scope

In the main body of this part of ISO 10302, the acquisition of the p - q curve of the fan under test is a prerequisite for airborne noise emission measurement. For this purpose, the methods of ISO 5801 based on measurement by using the air chamber are cited.

According to ISO 5801:2007, 22.4.2, Table 4, the applicability of the methods is limited to the condition with a Reynolds number of approximately 12 000 or higher. This Reynolds number corresponds to the lower limit of volume flow rate of approximately 0,01 m³/s.

Actual fans are becoming smaller and smaller, and are violating the Reynolds number assumption. Therefore a complementary method to ISO 5801 is required for these fans. In this part of ISO 10302, these fans are referred to as micro-fans (3.1.2).

This annex specifies a new methodology for p - q curve measurement of micro-fans, by reference to JBMS-72:2003, Annex A. Experimental data show that this method is useful to, at least, a maximum volume flow rate of 0,015 m³/s. See Figure A.1.

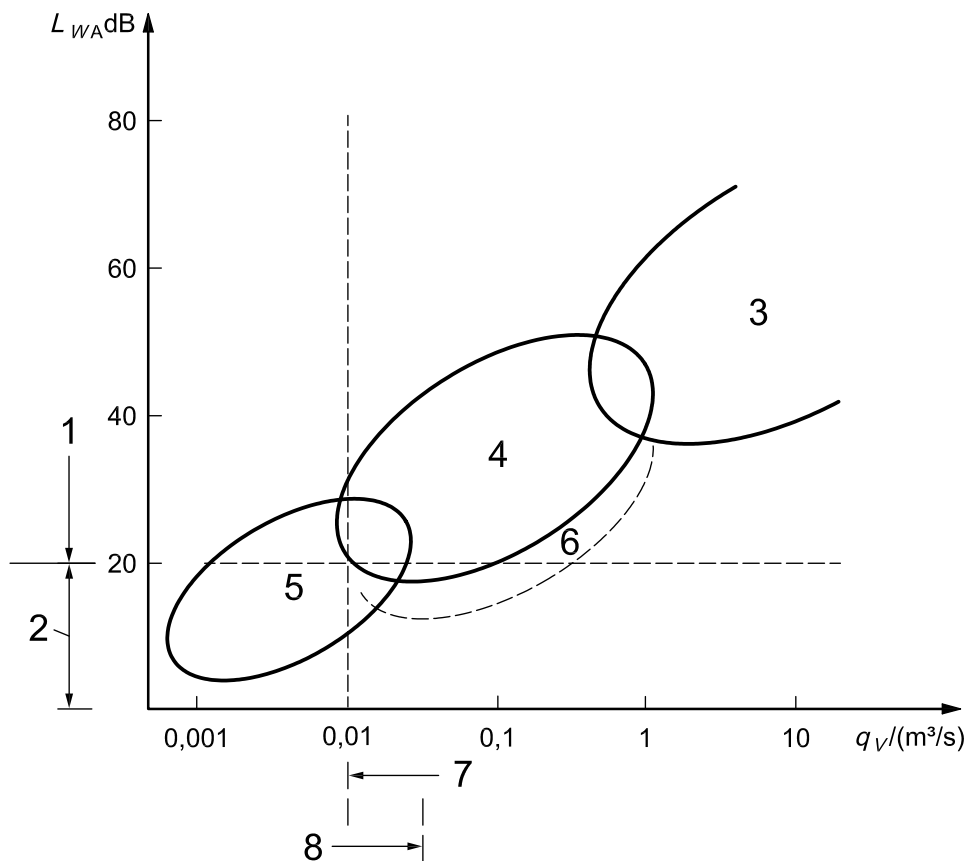

Key

- 1 lower limit of measurement by conventional method with 1 m radius (limit of conventional microphone)
 - 2 range in which new measurement method is required
 - 3 region intended for industrial fans
 - 4 region intended for business fans
 - 5 region of micro-fans
 - 6 extremely low noise fans
 - 7 approximate lower limit of measurement by conventional method based on ISO 5801
 - 8 approximate upper limit of volume flow rate in accordance with JBMS-72, Annex A = 0,015 m³/s
- L_{WA} A-weighted sound power level
 q_V volume flow rate

NOTE Figure A.1 was derived by translating JBMS-72:2003, Figure A.1 (see <http://www.jbmia.or.jp/hyojun/jbms-up/upload/list.cgi>), and shows schematic correlation between volume flow rate of micro-fans and conventional fans.

Figure A.1 — Schematic correlation of applicability of this annex and corresponding noise emissions (not to scale)

Annex B (informative)

Effects of air density

There are four principal effects of air density, a) to d), that require consideration in measurements of the sound power levels of aerodynamic sources such as fans.

- a) Changes in air density or ambient pressure produce changes in microphone sensitivity. Follow the manufacturer's instructions to ensure that the microphone is calibrated for ambient pressure.
- b) The sound power of the source, P , is determined from the value of the sound pressure using the expression in a free field:

$$P \propto \frac{p^2}{\rho c}$$

where

p^2 is the mean-squared value of the sound pressure;

ρ is the density of air;

c is the speed of sound.

If the free field over a reflecting plane method of ISO 7779 is used, then any correction for this effect should be made according to ISO 7779.

If the comparison reverberation test room method is used from ISO 7779, no explicit correction is necessary because the correction is inherently included in the comparison method. The use of the direct method of ISO 3741 is not permitted by this part of ISO 10302.

- c) The sound power radiated by many aerodynamic sources, e.g. axial fans and centrifugal fans, is proportional to air density.
- d) If the atmospheric density differs significantly from standard air conditions so as to change the rotational frequency of the AMD appreciably, an error due to this change may be introduced. In such a case, other quantities (e.g. motor current, electrical input power and overall static efficiency) may also change from their values under standard air conditions. This part of ISO 10302 does not provide for correction of the data to rotational frequencies of the AMD other than those existing during the measurements.

Annex C (informative)

Data formats for presentation

C.1 General

This annex gives sample data formats for reporting of acoustical noise emission of AMDs according to this part of ISO 10302. The contents are based on the requirements stated in Clause 11, but the others (e.g. sequences of each item, horizontal line spacing of spectrum graphs, and number of pages) are arbitrary and completely informative in nature.

In case of conflict, Clause 11 takes precedence over this annex.

C.2 Example

The following pages show one example.

Air-moving device acoustical noise emission test report

Sheet 2 of ____

Aerodynamic performance

L_{WA} reference
value 1 pW
dB

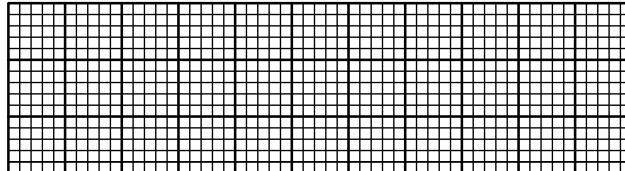

Rotational frequency
 min^{-1}

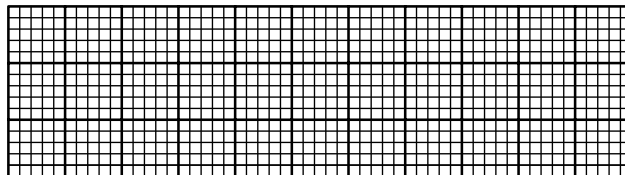

Fan static pressure
Pa

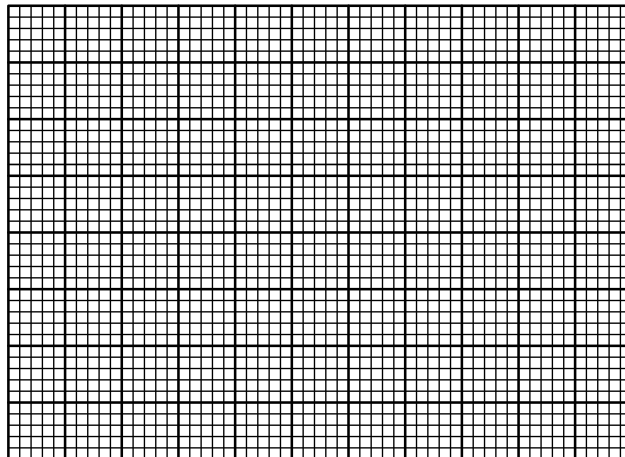

Volume flow rate under standard air condition (m^3/s)

Model: _____ Part/serial number: _____

Test voltage: _____ Power line frequency (if applicable): _____

Date: _____ Other information: _____

Air-moving device acoustical noise emission test report

Sheet 3 of ____

Sound power level spectrum

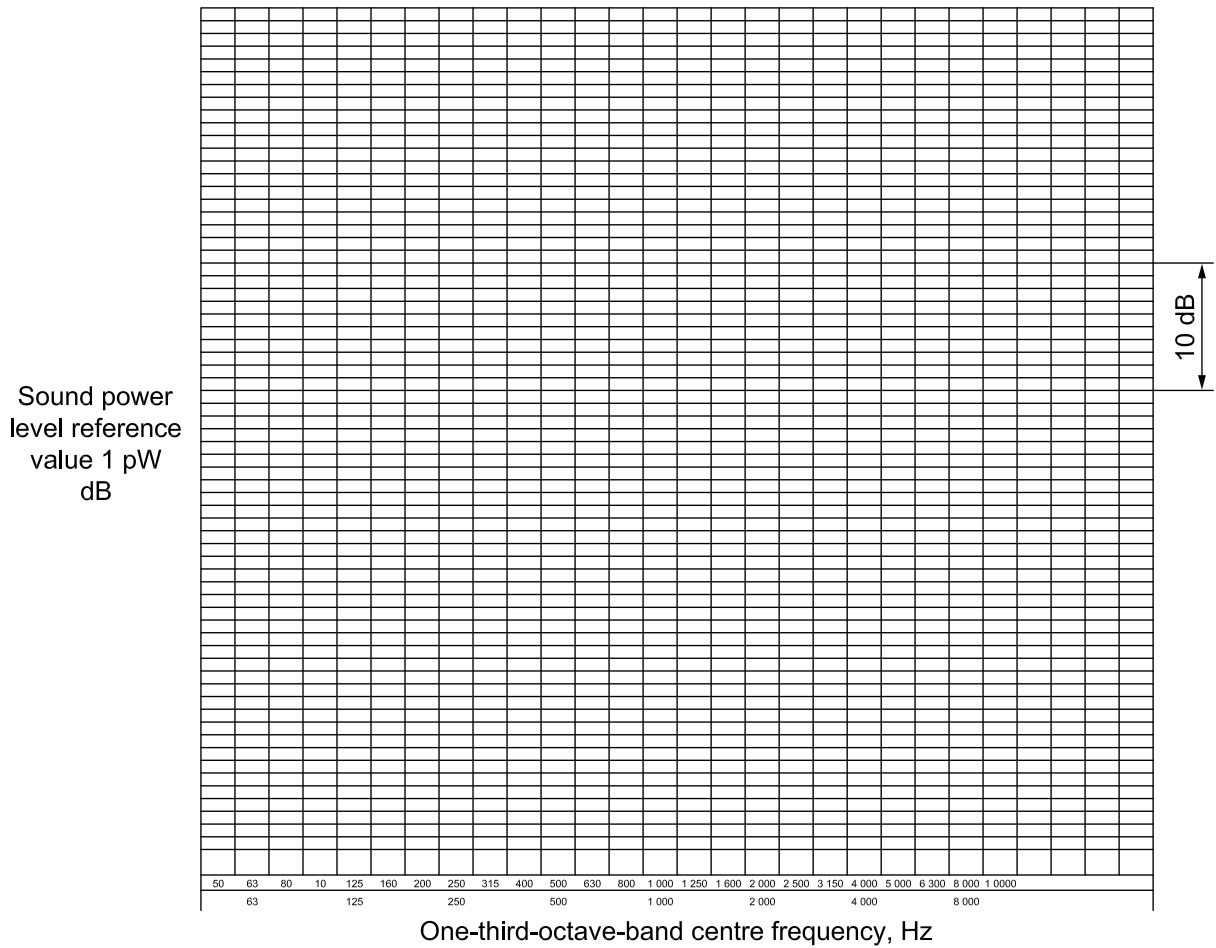

Model: _____ Part/serial number: _____

Test voltage: _____ Power line frequency (if applicable): _____

Date: _____ Other information: _____

Annex D (informative)

Air-moving device acoustical noise specification

D.1 General

This annex gives sample specification formats, as a function of aerodynamic performance, for declaring acoustical noise emissions of AMDs.

The formats are intended to declare the performance of each single AMD.

D.2 Specification formats for a single air-moving device

D.2.1 Determination of specification values

It is a basic assumption that specification values for the formats below are determined by evaluating the AMDs according to this part of ISO 10302.

The specifications described in D.2.2 and D.2.3 refer to the acoustical noise emissions and aerodynamic performance of a single AMD.

D.2.2 Recommended specification format

This air-moving device shall have an A-weighted sound power level not greater than [$_{_}$ dB/ $_{_}$ B] (the reference sound power is 1 pW) when evaluated in accordance with ISO 10302-1 and operating at [$_{_}$ V (DC)/ $_{_}$ V supply voltage, $_{_}$ Hz line frequency (AC)], and against a flow resistance corresponding to a fan static pressure of $_{_}$ Pa and a volume flow rate of $_{_}$ m³/s.

NOTE The contents in the square brackets (i.e. [$_{_}$ A/ $_{_}$ B]) are alternatives.

D.2.3 Alternative specification format

This air-moving device shall have an A-weighted sound power level not greater than [$_{_}$ dB/ $_{_}$ B] (the reference sound power is 1 pW) when evaluated in accordance with ISO 10302-1 and operating at [$_{_}$ V (DC) supply voltage/ $_{_}$ V (AC) supply voltage, $_{_}$ Hz line frequency], and against a flow resistance between one corresponding to a fan static pressure of $_{_}$ Pa and a volume flow rate of $_{_}$ m³/s, and one corresponding to a fan static pressure of $_{_}$ Pa and a volume flow rate of $_{_}$ m³/s.

NOTE The contents in the square brackets (i.e. [$_{_}$ A/ $_{_}$ B]) are alternatives.

D.3 Specification formats for a lot of air-moving devices

Additional information may be required to describe allowable variations in a batch of AMDs.

Annex E (informative)

Guidance on the development of information on measurement uncertainty

E.1 General

The standard deviation of reproducibility data given in Table 1 for provisional use in test reports is incomplete, not taking into account any potential uncertainty contribution due to the measurement method selected for the purpose of the interlaboratory comparison from which the values in the table were derived. Moreover, it cannot usually be ensured in such a comparison that all influence parameters have been representatively covered by the participating laboratories. Finally, the results of interlaboratory comparisons do not provide any analysis of the relevant components of uncertainty and their magnitudes and thus do not enable a laboratory to identify the major contributions to uncertainty and to improve corresponding measurement conditions in order to reduce the overall uncertainty, if requested.

The accepted format for the expression of uncertainties associated with measurement results is that given in ISO/IEC Guide 98-3. This format requests a functional relationship (model function) to be established between the measurand, which in the context of this part of ISO 10302 is the frequency-dependent sound power level emitted by an AMD, and several input quantities describing effects that may influence the measurement result. Each of these input quantities is characterized by its estimate, its probability distribution, and its standard uncertainty. The existing knowledge of these input quantities is to be compiled in an uncertainty budget from which the combined standard uncertainty and the standard deviation of reproducibility of the measurement result can be derived.

Scientifically verified data necessary to establish a generally valid uncertainty budget for each measurement performed in accordance with this part of ISO 10302 were not available at the time of publication. However, an indication of the relevant sources of uncertainty and their characteristics is given, mostly based on empirical knowledge. The general approach to the determination of uncertainties conforming to ISO/IEC Guide 98-3 is illustrated. It allows an approximate determination of uncertainties under special assumptions.

The evaluation of measurement uncertainty is the final responsibility of each laboratory performing a measurement. Even if the requirements of this part of ISO 10302 are fully met, the uncertainty of results from different laboratories may differ depending on the specific measurement conditions. This annex should therefore only be regarded as a guide.

NOTE Interlaboratory comparisons in accordance with ISO 5725^[3] constitute a very useful tool to check uncertainty evaluations in accordance with ISO/IEC Guide 98-3. However, for reasons given above, they cannot fully replace such evaluations.

E.2 Model function

This part of ISO 10302 permits the sound power level emitted by an AMD to be determined either in an essentially free sound field over a reflecting plane based on ISO 3744 or ISO 3745, respectively, or by a comparison method in a reverberation room, based on ISO 3741. For each of these measurement methods, a slightly different model function is valid. In the following uncertainty evaluation, a measurement in accordance with ISO 3744 is chosen as an example and a model function and its further discussion in this annex is based on this measurement method. However, the treatment of measurement uncertainty for a measurement in accordance with ISO 3741 or ISO 3745 is, with some modifications, quite similar.

The sound power level of a noise source, L_W , determined in accordance with ISO 3744 and corrected for meteorological conditions, is a function of a number of parameters, as defined by Equation (E.1):

$$L_W = \left(\overline{L'_{p(ST)}} + K_1 + 10 \lg \frac{S}{S_0} - K_2 + C + \delta_{\text{angle}} + \delta_{\text{slm}} + \delta_{\text{mount}} + \delta_{\text{oc}} + \delta_{\text{mic}} + \delta_{\text{meth}} \right) \quad (\text{E.1})$$

where

$\overline{L'_{p(ST)}}$ is the mean time-averaged sound pressure level over the measurement surface, with the AMD under test in operation, in decibels, as defined in ISO 3744;

NOTE 1 L_W as well as $\overline{L'_{p(ST)}}$ can either indicate a one-third-octave-band or an A-weighted level.

K_1 is the background noise correction, in decibels, as defined in ISO 3744;

S is the area of the measurement surface, in square metres, with $S_0 = 1 \text{ m}^2$;

K_2 is the environmental correction, in decibels, as defined in ISO 3744;

C is a meteorological and radiation impedance correction to account for different reference quantities in sound pressure level and sound power level and for changes of sound power level with ambient temperature and ambient pressure, in decibels, $C = C_1 + C_2$, as defined in ISO 3744;

δ_{angle} is a correction to account for any difference of angle between the direction in which the sound is emitted by the source and the normal to the measurement surface, in decibels;

δ_{slm} is an input quantity to allow for any uncertainty in the sound pressure measuring instrumentation, in decibels;

δ_{mount} is an input quantity to allow for any variability in the mounting conditions of the noise source under test, in decibels;

δ_{oc} is an input quantity to allow for any deviation in the operating conditions of the noise test under test from nominal conditions, in decibels;

δ_{mic} is an input quantity to allow for any uncertainty due to the finite number of microphone positions, in decibels;

δ_{meth} is an input quantity to allow for any uncertainty due to the applied measurement method, in decibels.

NOTE 2 The input quantities in Equation (E.1) to allow for uncertainties are those thought to be applicable in the state of knowledge at the time of publication of this part of ISO 10302, but further research could reveal that there are others.

A probability distribution (normal, rectangular, Student t , etc.) is associated with each of these input quantities. Its expectation value (mean value) is the best estimate for the value of the input quantity and its standard deviation is a measure of the dispersion of values. The uncertainty in the estimate of an input quantity is termed its standard uncertainty. It is a function of the standard deviation, probability distribution, and number of degrees of freedom.

NOTE 3 Unless stated otherwise in E.3, a normal distribution of values associated with each of the input quantities may be assumed.

E.3 Input quantities and their contributions to measurement uncertainty

E.3.1 General

The contributions of the various input quantities to the overall measurement uncertainty depend on their associated standard uncertainties and their sensitivity coefficients. The sensitivity coefficients are a measure of how the values of the sound power level are affected by changes in the values of the respective input quantities. Mathematically, these coefficients are equal to the partial derivatives of the function L_W [Equation (E.1)] with respect to the relevant input quantities. The contributions to the overall uncertainty are then given by the products of standard uncertainties, u_i , and sensitivity coefficients, c_i .

NOTE For simplification in the context of this part of ISO 10302, potential correlation between any of the input quantities is neglected, though further research could reveal that correlation between any of the input quantities has a significant influence on the measurement uncertainty thus evaluated.

E.3.2 Mean time-averaged sound pressure level, $\overline{L'_{p(ST)}}$

The mean time-averaged sound pressure level of the source under test is usually determined only once. This result is considered to be a suitable estimate of the quantity. Its standard uncertainty, indicating the repeatability of this value, requires determination separately by a number (at least 6) of successive measurements carried out at a single microphone position under identical conditions (i.e. same measurement procedure, same observer, same measuring instrument, same location, but with the measuring instrument removed and installed again between trials). The standard deviation s of the values of these measurements may be taken as the standard uncertainty of $\overline{L'_{p(ST)}}$.

The sensitivity coefficient is the partial derivative of L_W [Equation (E.1)], with respect to $\overline{L'_{p(ST)}}$ and is given, after substitution for K_1 in accordance with its definition, by

$$C_{\overline{L'_{p(ST)}}} = 1 + \frac{1}{10^{0,1\Delta p} - 1}$$

If Δp is larger than 10 dB, this may be simplified to $C_{\overline{L'_{p(ST)}}} = 1$.

NOTE For extremely low noise sources, background noise can adversely lead to a large sensitivity coefficient and considerably increase the uncertainty contribution.

Measurement repeatability may be strongly influenced by averaging time. If chosen appropriately, the short-term repeatability is typically small (less than 0,1 dB), so that the contribution to the overall measurement uncertainty amounts to 0,1 dB.

E.3.3 Background noise correction, K_1

An estimate of K_1 is derived from measurements of the mean time-averaged sound pressure levels of the source under test and of background noise in accordance with its definition. The standard uncertainty of the background noise correction may be obtained from the standard deviation, s , of the results of repeated measurements (at least 6) of the background level difference ΔL_p , at a single microphone position on the measurement surface.

Since the relationship between L_W and $\overline{L'_{p(ST)}}$ is already covered by E.3.2, the sensitivity coefficient of the background noise correction is obtained as the partial derivative of the sound power level, L_W , with respect to the background noise level $L_{p(B)}$ and is given by

$$C_{K_1} = \frac{1}{10^{0,1\Delta p} - 1}$$

The contribution of the background noise correction to the overall measurement uncertainty is not generally quantifiable. Especially for a low noise source under test, the effect might not be negligible and needs to be examined carefully.

E.3.4 Measurement surface area, S

For a hemispherical measurement surface, the estimate for $S = 2\pi r^2$ is calculated for a given value of the radius r of the hemisphere. The standard uncertainty depends on the uncertainty of the realization of the defined microphone positions on this surface. If the uncertainty in the measurement surface dimensions is assumed to have a rectangular distribution with a range of $\pm\Delta r$, the standard deviation results in

$$u_S = \frac{\Delta r}{\sqrt{3}}$$

The sensitivity coefficient is obtained from the derivative of L_W with respect to r . After substitution for the surface area $S = 2\pi r^2$, the sensitivity coefficient is $c = 8,7/r$.

Typically an uncertainty contribution of 0,1 dB is achievable with very careful microphone positioning.

NOTE Similar considerations are valid for other geometries of the measurement surface in accordance with ISO 3744.

E.3.5 Correction for acoustical environment correction, K_2

An estimate of the correction for acoustical environment should be determined by any of the alternative procedures specified in ISO 3744:2010, Annex A. From practical experience, the standard uncertainty can be assumed to be approximately equal to $u_{K_2} = K_2/4$ leading to a value of $u_{K_2} = 0,5$ dB for an environmental correction of $K_2 = 2$ dB.

NOTE ISO 7779, which relies on this part of ISO 10302, permits the use of free field over a reflecting plane only with $K_2 \leq 2$ dB, while ISO 3744 permits $K_2 \leq 4$ dB.

With this assumption about u_{K_2} , the sensitivity coefficient is equal to 1, resulting in an uncertainty contribution of 1,0 dB. A smaller contribution could be obtained by reducing the measurement distance or reduction of K_2 by changing rooms, increasing the room absorption, or by opening large doors and windows. Typically, a value of $c_{K_2} u_{K_2} = 0,5$ dB can be achieved.

E.3.6 Meteorological correction, C

For simplicity, the two corrections C_1 and C_2 defined in ISO 3744 can be treated together. If meteorological conditions significantly deviate from reference conditions (e.g. if measurements are carried out at a height of more than 500 m above sea level), a correction has to be applied. The estimate of the sum of the two quantities is determined in accordance with their definition. The standard uncertainty of the sum is about $u_c = 0,2$ dB. The sensitivity coefficient of the sum is equal to 1, resulting in an uncertainty contribution of 0,2 dB.

For other meteorological conditions, or if no correction is applied at all, different standard uncertainties have to be estimated.

E.3.7 Angle of sound incidence, δ_{angle}

The use of sound pressure to approximate the sound intensity basically leads to an overestimate of the sound power. The magnitude of this overestimation depends on the sound source, its directional characteristics and the measurement distance. No generally valid relationships, either for an approximate estimate or for its standard uncertainty, can be given. For small AMDs, usually no correction needs to be applied. It is recommended that a value for a reasonable standard uncertainty be derived experimentally by investigating different sound sources using different methods (i.e. sound pressure versus sound intensity measurements).

For a hemispherical measurement surface in a free field above a reflecting plane, the standard deviation is $u_{\text{angle}} = 0,25$ dB.

NOTE At high frequencies, the microphone directivity can compensate for the angle error.

Unless more specific knowledge is available for the kind of sound sources under test, a sensitivity coefficient of 1 may be assumed for simplicity reasons.

E.3.8 Sound measuring instrumentation, δ_{slm}

The estimate of δ_{slm} is zero and the corresponding sensitivity coefficient is 1. The standard uncertainty u due to performance deviations of the measuring instrumentation from nominal performance depends on the class of instrumentation in accordance with IEC 61672-1^[6], and on frequency and other characteristics of the noise to be measured. For a well-calibrated class 1 instrument at medium frequencies, and for a broadband and approximately stationary noise character, u_{slm} may be assumed to be typically 0,5 dB. For different measurement conditions, reference is made to IEC 61672-1^[6].

E.3.9 Mounting conditions, δ_{mount}

The estimate of δ_{mount} is 0 dB and the corresponding sensitivity coefficient is 1. Mounting conditions are specified in Clauses 5 and 6. They include the design and performance for the test plenum including the requirements on the instrumentation for static pressure and the installation of the test plenum in the test room. The uncertainty due to any variability in these mounting conditions, u_{mount} , may further depend on the characteristics of the AMD under test. A generally valid figure for its magnitude can therefore not be given. It is recommended that a number of noise measurements be performed on different sound sources under different mounting conditions within the tolerances specified in Clauses 5 and 6 under otherwise identical conditions. The standard deviation of the results may then be taken as a suitable estimate of u_{mount} .

E.3.10 Operating conditions, δ_{oc}

The estimate of δ_{oc} is 0 dB and the corresponding sensitivity coefficient is 1. Operating conditions are specified in Clause 7 for different points of operation. They may differently affect various AMDs. Due to the variability of conditions within these specifications, a generally valid figure for the standard uncertainty due to different operating conditions cannot be given. It is recommended that a number of noise measurements be performed under different operating conditions within the tolerances given in Clause 7 under otherwise identical conditions. The standard deviation of the results of these measurements may be taken as a suitable estimate of the standard uncertainty u_{oc} . Multiple changes in operating conditions may be randomly assigned between tests.

E.3.11 Sampling, δ_{mic}

The finite number of microphone positions is not reflected by any correction to the measurement result, i.e. the estimate of δ_{mic} is zero. However, its standard uncertainty needs to be considered. It is given by

$$u_{mic} = \frac{u_{L'p(ST)}}{\sqrt{n}} = \frac{V_1^*}{\sqrt{n}} = \frac{1}{\sqrt{n}} \sqrt{\frac{1}{(n-1)} \sum_{i=1}^n [L'_{pi(ST)} - L'_{pav}]^2}$$

where V_1^* is the apparent surface sound pressure level non-uniformity index as defined in ISO 3744, and n is the number of microphone positions. Considering the relative small sound sources, the range of measured sound pressure levels at different microphone positions is typically less than 5 dB and, assuming a minimum of nine microphone positions, a typical value of $u_{mic} = 0,7$ dB results.

The sensitivity coefficient $u_{mic} = 1$. The uncertainty contribution can be reduced by increasing the number of measurement positions, or increasing the measurement distance, if necessary.

E.3.12 Measurement method, δ_{meth}

Different measurement methods may lead to different results. No generally valid figure for any correction can presently be given, i.e. the estimate of δ_{meth} is taken as zero. However, based on empirical knowledge, a standard uncertainty of $u_{meth} = 0,4$ dB may be assumed. With a sensitivity coefficient of $c_{meth} = 1$, this results in an uncertainty contribution of 0,4 dB.

E.4 Uncertainty budget

All available information on the various input quantities as indicated in E.3 should be compiled in an uncertainty budget allowing an easy overview of the most significant uncertainty contributions to enable a decision on which of the various input quantities can finally be neglected and which need more thorough consideration. A skeleton uncertainty budget with some generally valid entries is given in Table E.1 as an example.

Table E.1 — Example of an uncertainty budget for determination of sound power

Quantity	Estimate dB	Standard uncertainty u dB	Probability distribution	Sensitivity coefficient c	Uncertainty contribution $u c$ dB
$\overline{L'_{p(ST)}}$	$\overline{L'_{p(ST),est}}$	$u_{L_{p(ST)}}$	Normal	$1 + \frac{1}{10^{0,1\Delta p} - 1}$	$u c$
K_1	$K_{1,est}$	u_{K_1}	Normal	$\frac{1}{10^{0,1\Delta p} - 1}$	$u c$
S	S_{est}	$\Delta r/\sqrt{3}$	Rectangular	$8,7/r$	$u c$
K_2	$K_{2,est}$	u_{K_2}	Normal	1	u_{K_2}
C	C_{est}	u_C	Normal	1	u_C
δ_{angle}	0,25	u_{angle}	Normal	1	u_{angle}
δ_{slm}	0	u_{slm}	Normal	1	u_{slm}
δ_{mount}	0	u_{mount}	Normal	1	u_{mount}
δ_{oc}	0	u_{oc}	Normal	1	u_{oc}
δ_{mic}	0	u_{mic}	Normal	1	u_{mic}
δ_{meth}	0	u_{meth}	Normal	1	u_{meth}

E.5 Combined standard uncertainty and expanded uncertainty

From the individual contributions as described in E.3 and as compiled in an uncertainty budget in E.4, the combined standard uncertainty u_{L_W} can be calculated in accordance with

$$u_{L_W} = \sqrt{\sum_i (u_i c_i)^2} \quad (E.2)$$

ISO/IEC Guide 98-3 requires an expanded measurement uncertainty, U , to be specified so that the interval $[L_W - U, L_W + U]$ covers for example 95 % of the values that might reasonably be attributed to L_W . To that purpose, a coverage factor k is used such that

$$U_{L_W} = k u_{L_W} \quad (E.3)$$

The expanded uncertainty depends on the degree of confidence that is desired. For a normal distribution of measured values, there is 95 % confidence that the true value lies within the range $[L_W - U]$ to $[L_W + U]$ (or $[L_J - U]$ to $[L_J + U]$). This corresponds to a coverage factor of $k = 2$.

If the purpose of determining the sound power level is to compare the result with a limit value, it might be more appropriate to apply the coverage factor for a one-sided normal distribution. In that case, the coverage factor $k = 1,6$ corresponds to 95 % confidence.

Bibliography

- [1] ISO 266, *Acoustics — Preferred frequencies*
- [2] ISO 4871, *Acoustics — Declaration and verification of noise emission values of machinery and equipment*
- [3] ISO 5725:1986, *Precision of test methods — Determination of repeatability and reproducibility for a standard test method by inter-laboratory tests*²⁾
- [4] ISO 9613-1, *Acoustics — Attenuation of sound during propagation outdoors — Part 1: Calculation of the absorption of sound by the atmosphere*
- [5] ISO 13347 (all parts), *Industrial fans — Determination of fan sound power levels under standardized laboratory conditions*
- [6] IEC 61672-1, *Electroacoustics — Sound level meters — Part 1: Specifications*
- [7] ANSI/ASA S12.11-1, *Acoustics — Measurement of noise and vibration of small air-moving devices, Part 1: Airborne noise emission*³⁾
- [8] ANSI/ASA S12.11-2, *Acoustics — Measurement of noise and vibration of small air-moving devices, Part 2: Structure-borne vibration*
- [9] ECMA-275, *Measurement of structure-borne vibration induced by small air moving devices (AMDs)*. Available (2010-12-14) at: <http://www.ecma-international.org/publications/files/ECMA-ST/Ecma-275.pdf>
- [10] LOTZ, R. Precision of a new International Standard for measurement of fan noise — ISO/DIS 10302. Noise-Con 91, pp. 118-226
- [11] PROBST, W. *Checking of sound emission values*. Bremerhaven: Wirtschaftsverlag NW, Verlag für Neue Wissenschaft, 1999. 102 p. (*Schriftenreihe der Bundesanstalt für Arbeitsschutz und Arbeitsmedizin* [Federal Institute of Industrial Health and Safety publications series], Dortmund: Fb [special report] 851)

2) Superseded.

3) Adoption of ISO 10302:1996.

British Standards Institution (BSI)

BSI is the national body responsible for preparing British Standards and other standards-related publications, information and services.

BSI is incorporated by Royal Charter. British Standards and other standardization products are published by BSI Standards Limited.

About us

We bring together business, industry, government, consumers, innovators and others to shape their combined experience and expertise into standards-based solutions.

The knowledge embodied in our standards has been carefully assembled in a dependable format and refined through our open consultation process. Organizations of all sizes and across all sectors choose standards to help them achieve their goals.

Information on standards

We can provide you with the knowledge that your organization needs to succeed. Find out more about British Standards by visiting our website at bsigroup.com/standards or contacting our Customer Services team or Knowledge Centre.

Buying standards

You can buy and download PDF versions of BSI publications, including British and adopted European and international standards, through our website at bsigroup.com/shop, where hard copies can also be purchased.

If you need international and foreign standards from other Standards Development Organizations, hard copies can be ordered from our Customer Services team.

Subscriptions

Our range of subscription services are designed to make using standards easier for you. For further information on our subscription products go to bsigroup.com/subscriptions.

With **British Standards Online (BSOL)** you'll have instant access to over 55,000 British and adopted European and international standards from your desktop. It's available 24/7 and is refreshed daily so you'll always be up to date.

You can keep in touch with standards developments and receive substantial discounts on the purchase price of standards, both in single copy and subscription format, by becoming a **BSI Subscribing Member**.

PLUS is an updating service exclusive to BSI Subscribing Members. You will automatically receive the latest hard copy of your standards when they're revised or replaced.

To find out more about becoming a BSI Subscribing Member and the benefits of membership, please visit bsigroup.com/shop.

With a **Multi-User Network Licence (MUNL)** you are able to host standards publications on your intranet. Licences can cover as few or as many users as you wish. With updates supplied as soon as they're available, you can be sure your documentation is current. For further information, email bsmusales@bsigroup.com.

BSI Group Headquarters

389 Chiswick High Road London W4 4AL UK

Revisions

Our British Standards and other publications are updated by amendment or revision.

We continually improve the quality of our products and services to benefit your business. If you find an inaccuracy or ambiguity within a British Standard or other BSI publication please inform the Knowledge Centre.

Copyright

All the data, software and documentation set out in all British Standards and other BSI publications are the property of and copyrighted by BSI, or some person or entity that owns copyright in the information used (such as the international standardization bodies) and has formally licensed such information to BSI for commercial publication and use. Except as permitted under the Copyright, Designs and Patents Act 1988 no extract may be reproduced, stored in a retrieval system or transmitted in any form or by any means – electronic, photocopying, recording or otherwise – without prior written permission from BSI. Details and advice can be obtained from the Copyright & Licensing Department.

Useful Contacts:

Customer Services

Tel: +44 845 086 9001

Email (orders): orders@bsigroup.com

Email (enquiries): cservices@bsigroup.com

Subscriptions

Tel: +44 845 086 9001

Email: subscriptions@bsigroup.com

Knowledge Centre

Tel: +44 20 8996 7004

Email: knowledgecentre@bsigroup.com

Copyright & Licensing

Tel: +44 20 8996 7070

Email: copyright@bsigroup.com



...making excellence a habit.™