

BS ISO 10300-2:2014



BSI Standards Publication

Calculation of load capacity of bevel gears

Part 2: Calculation of surface durability
(pitting)

bsi.

...making excellence a habit.™

National foreword

This British Standard is the UK implementation of ISO 10300-2:2014. It supersedes BS ISO 10300-2:2001 which is withdrawn.

The UK participation in its preparation was entrusted to Technical Committee MCE/5/-/13, Bevel gears.

A list of organizations represented on this committee can be obtained on request to its secretary.

This publication does not purport to include all the necessary provisions of a contract. Users are responsible for its correct application.

© The British Standards Institution 2014. Published by BSI Standards Limited 2014

ISBN 978 0 580 71822 9

ICS 21.200

Compliance with a British Standard cannot confer immunity from legal obligations.

This British Standard was published under the authority of the Standards Policy and Strategy Committee on 31 March 2014.

Amendments issued since publication

Date	Text affected
------	---------------

INTERNATIONAL
STANDARD

ISO
10300-2

Second edition
2014-04-01

**Calculation of load capacity of bevel
gears —**

Part 2:
**Calculation of surface durability
(pitting)**

Calcul de la capacité de charge des engrenages coniques —

*Partie 2: Calcul de la résistance à la pression superficielle (formation
des piqûres)*



Reference number
ISO 10300-2:2014(E)

© ISO 2014



COPYRIGHT PROTECTED DOCUMENT

© ISO 2014

All rights reserved. Unless otherwise specified, no part of this publication may be reproduced or utilized otherwise in any form or by any means, electronic or mechanical, including photocopying, or posting on the internet or an intranet, without prior written permission. Permission can be requested from either ISO at the address below or ISO's member body in the country of the requester.

ISO copyright office
Case postale 56 • CH-1211 Geneva 20
Tel. + 41 22 749 01 11
Fax + 41 22 749 09 47
E-mail copyright@iso.org
Web www.iso.org

Published in Switzerland

Contents

Page

Foreword.....	iv
Introduction.....	v
1 Scope.....	1
2 Normative references.....	1
3 Terms and definitions.....	1
4 Symbols, units and abbreviated terms.....	2
5 Pitting damage — General aspects.....	3
5.1 Acceptable versus unacceptable pitting.....	3
5.2 Assessment requirements.....	3
5.3 General rating procedure.....	4
6 Gear flank rating formulae — Method B1.....	4
6.1 Contact stress formula.....	4
6.2 Permissible contact stress.....	6
6.3 Calculated safety factor for contact stress.....	6
6.4 Contact stress factors.....	6
6.5 Permissible contact stress factors.....	10
7 Gear flank rating formulae — Method B2.....	13
7.1 Contact stress formula.....	13
7.2 Permissible contact stress.....	14
7.3 Calculated safety factor for contact stress.....	14
7.4 Contact stress factors.....	15
8 Factors for contact stress and permissible contact stress common for method B1 and method B2.....	20
8.1 Elasticity factor, Z_E	20
8.2 Lubricant film influence factors, Z_L, Z_V, Z_R	20
8.3 Work hardening factor, Z_W	24
8.4 Life factor, Z_{NT}	25
Annex A (informative) Bevel slip factor Z_S — Method B1.....	28
Bibliography.....	30

Foreword

ISO (the International Organization for Standardization) is a worldwide federation of national standards bodies (ISO member bodies). The work of preparing International Standards is normally carried out through ISO technical committees. Each member body interested in a subject for which a technical committee has been established has the right to be represented on that committee. International organizations, governmental and non-governmental, in liaison with ISO, also take part in the work. ISO collaborates closely with the International Electrotechnical Commission (IEC) on all matters of electrotechnical standardization.

The procedures used to develop this document and those intended for its further maintenance are described in the ISO/IEC Directives, Part 1. In particular the different approval criteria needed for the different types of ISO documents should be noted. This document was drafted in accordance with the editorial rules of the ISO/IEC Directives, Part 2. www.iso.org/directives

Attention is drawn to the possibility that some of the elements of this document may be the subject of patent rights. ISO shall not be held responsible for identifying any or all such patent rights. Details of any patent rights identified during the development of the document will be in the Introduction and/or on the ISO list of patent declarations received. www.iso.org/patents

Any trade name used in this document is information given for the convenience of users and does not constitute an endorsement.

For an explanation on the meaning of ISO specific terms and expressions related to conformity assessment, as well as information about ISO's adherence to the WTO principles in the Technical Barriers to Trade (TBT) see the following URL: [Foreword - Supplementary information](#)

The committee responsible for this document is ISO/TC 60, *Gears*, Subcommittee SC 2, *Gear capacity calculation*.

This second edition cancels and replaces the first edition (ISO 10300-2:2001), which has been technically revised.

ISO 10300 consists of the following parts, under the general title *Calculation of load capacity of bevel gears*:

- *Part 1: Introduction and general influence factors*
- *Part 2: Calculation of surface durability (pitting)*
- *Part 3: Calculation of tooth root strength*

Introduction

When ISO 10300:2001 (all parts, withdrawn) became due for (its first) revision, the opportunity was taken to include hypoid gears, since previously the series only allowed for calculating the load capacity of bevel gears without offset axes. The former structure is retained, i.e. three parts of the ISO 10300 series, together with ISO 6336-5, and it is intended to establish general principles and procedures for rating of bevel gears. Moreover, ISO 10300 (all parts) is designed to facilitate the application of future knowledge and developments, as well as the exchange of information gained from experience.

In view of the decision for ISO 10300 (all parts) to cover hypoid gears also, it was agreed to include a separate clause: “Gear flank rating formulae — Method B2” in this part of ISO 10300, while the former method B was renamed method B1. So, it became necessary to present a new, clearer structure of the three parts, which is illustrated in ISO 10300-1:2014, Figure 1. Note, ISO 10300 (all parts) gives no preferences in terms of when to use method B1 and when method B2.

This part of ISO 10300 deals with the failure of gear teeth by pitting, a fatigue phenomenon. Two varieties of pitting are recognized, initial and destructive pitting.

In applications employing low hardness steel or through hardened steel, initial pitting frequently occurs during early use and is not deemed serious. Initial pitting is characterized by small pits which do not extend over the entire face width or profile depth of the affected tooth. The degree of acceptability of initial pitting varies widely, depending on the gear application. Initial pitting occurs in localized overstressed areas, and tends to redistribute the load by progressively removing high contact spots. Generally, when the load has been redistributed, the pitting stops.

In applications employing high hardness steel and case carburized steel, the variety of pitting that occurs is usually destructive. The formulae for pitting resistance given in this part of ISO 10300 are intended to assist in the design of bevel gears which stay free from destructive pitting during their design lives (for additional information, see ISO/TR 22849^[4]).

The basic formulae, first developed by Hertz for the contact pressure between two curved surfaces, have been modified to consider the following four items: the load sharing between adjacent teeth, the position of the centre of pressure on the tooth, the shape of the instantaneous area of contact, and the load concentration resulting from manufacturing uncertainties. The Hertzian contact pressure serves as the theory for the assessment of surface durability with respect to pitting. Although all premises for a gear mesh are not satisfied by Hertzian relations, their use can be justified by the fact that, for a gear material, the limits of the Hertzian pressure are determined on the basis of running tests with gears, which include the additional influences in the analysis of the limit values. Therefore, if the reference is within the application range, Hertzian pressure can be used to convert test gear data to gears of various types and sizes.

NOTE Contrary to cylindrical gears, where the contact is usually linear, bevel gears are generally manufactured with profile and lengthwise crowning: i.e. the tooth flanks are curved on all sides and the contact develops an elliptical pressure surface. This is taken into consideration when determining the load factors by the fact that the rectangular pressure zone of action (in the case of spur and helical gears) is replaced by an inscribed parallelogram for method B1 and an inscribed ellipse for method B2 (see [Annex A](#) for method B1 and [Annex B](#) for method B2). The conditions for bevel gears, different from cylindrical gears in their contact, are thus taken into consideration by the longitudinal and transverse load distribution factors.

Calculation of load capacity of bevel gears —

Part 2: Calculation of surface durability (pitting)

1 Scope

This part of ISO 10300 specifies the basic formulae for use in the determination of the surface load capacity of straight and helical (skew), Zerol and spiral bevel gears including hypoid gears, and comprises all the influences on surface durability for which quantitative assessments can be made. This part of ISO 10300 is applicable to oil lubricated bevel gears, as long as sufficient lubricant is present in the mesh at all times.

The formulae in this part of ISO 10300 are based on virtual cylindrical gears and restricted to bevel gears whose virtual cylindrical gears have transverse contact ratios of $\varepsilon_{v\alpha} < 2$. The results are valid within the range of the applied factors as specified in ISO 10300-1 (see ISO 6336-2[1]). Additionally, the given relations are valid for bevel gears of which the sum of profile shift coefficients of pinion and wheel is zero (see ISO 23509).

The formulae in this part of ISO 10300 are not directly applicable to the assessment of other types of gear tooth surface damage, such as plastic yielding, scratching, scuffing or any other type not specified.

WARNING — The user is cautioned that when the formulae are used for large average mean spiral angles $(\beta_{m1} + \beta_{m2})/2 > 45^\circ$, for effective pressure angles $\alpha_e > 30^\circ$ and/or for large face widths $b > 13 m_{mn}$, the calculated results of ISO 10300 should be confirmed by experience.

2 Normative references

The following documents, in whole or in part, are normatively referenced in this document and are indispensable to its application. For dated references, only the edition cited applies. For undated references, the latest edition of the referenced document (including any amendments) applies.

ISO 1122-1, *Vocabulary of gear terms — Part 1: Definitions related to geometry*

ISO 6336-5, *Calculation of load capacity of spur and helical gears — Part 5: Strength and quality of materials*

ISO 10300-1:2014, *Calculation of load capacity of bevel gears — Part 1: Introduction and general influence factors*

ISO 10300-3, *Calculation of load capacity of bevel gears — Part 3: Calculation of tooth root strength*

ISO 23509, *Bevel and hypoid gear geometry*

3 Terms and definitions

For the purposes of this document, the terms and definitions given in ISO 1122-1 and ISO 23509 (geometrical gear terms) and the following apply.

3.1

pitting

material fatigue phenomenon of two meshing surfaces under load

**3.2
 nominal contact stress**

σ_{H0}
 contact stress calculated on the basis of the Hertzian theory at the critical point of load application for error-free gears loaded by a constant nominal torque

**3.3
 contact stress**

σ_H
 determinant contact stress at the critical point of load application including the load factors which consider static and dynamic loads and load distribution

**3.4
 allowable stress number**

$\sigma_{H,lim}$
 maximum contact stress of standardized test gears and determined at standardized operating conditions, as specified in ISO 6336-5

**3.5
 permissible contact stress**

σ_{HP}
 maximum contact stress of the evaluated gear set including all influence factors

4 Symbols, units and abbreviated terms

For the purposes of this document, the symbols and units given in ISO 10300-1:2014, Table 1 and Table 2, as well as the following abbreviated terms, apply (see ISO 6336-5).

Table 1 — Abbreviated terms

Abbreviated term	Material	Type
St	Normalized low carbon steels/cast steels	Wrought normalized low carbon steels
St (cast)		Cast steels
GTS (perl.)	Cast iron materials	Black malleable cast iron (perlitic structure)
GGG (perl., bai., ferr.)		Nodular cast iron (perlitic, bainitic, ferritic structure)
GG		Grey cast iron
V	Through hardened wrought steels	Carbon steels, alloy steels
V (cast)	Through hardened cast steels	Carbon steels, alloy steels
Eh	Case-hardened wrought steels	
IF	Flame or induction hardened wrought or cast steels	
NT (nitr.)	Nitrided wrought steels/nitriding steels/through hardening steels, nitrided	Nitriding steels
NV (nitr.)		Through hardening steels
NV (nitocar.)	Wrought steels, nitrocarburized	Through hardening steels

5 Pitting damage — General aspects

5.1 Acceptable versus unacceptable pitting

When limits of the surface durability of the meshing flanks are exceeded, particles break out of the flank, thus leaving pits. The extent, to which such pits may be tolerated, in terms of their size and number, varies within wide limits which depend largely on the field of application. In some fields, extensive pitting is acceptable; in others, no pitting is acceptable. The descriptions in 5.2 and 5.3 are relevant to average working conditions and give guidelines to distinguish between initial and destructive, and acceptable and unacceptable, pitting varieties.

A linear or progressive increase in the total area of pits (linear or progressive pitting) is generally considered to be unacceptable. However, it is possible that the effective tooth bearing area is enlarged by initial pitting, and the rate of pit generation subsequently decreases (degressive pitting), or even ceases (arrested pitting), and then may be considered tolerable. Nevertheless, where there is dispute over the acceptability of pitting the next subclause shall be determinant.

5.2 Assessment requirements

Pitting involving the formation of pits which increase linearly or progressively with time under unchanged service conditions shall be unacceptable. Damage assessment shall include the entire active area of all the tooth flanks. The number and size of newly developed pits in unhardened tooth flanks shall be taken into consideration. Pits are frequently formed on just one, or only a few, of the surface hardened gear tooth flanks. In such circumstances, assessment shall be centred on the flanks actually pitted.

Teeth suspected of being especially at risk should be marked for critical examination if a quantitative evaluation is required.

In special cases, it is possible that a first, rough assessment can be based on considerations of the entire quantity of wear debris. But in critical cases, the condition of the flanks should be examined at least three times. The first time, however, the examination should take place only after at least 10^6 cycles of load. Depending on the results of previous examinations, further ones should be carried out after a period of service.

When deterioration caused by pitting is such that it puts human life in danger, or poses a risk of other grave consequences, the pitting shall not be tolerated. Due to stress concentration effects, a pit of 1 mm in diameter near the fillet of a through hardened or case hardened gear tooth can become the origin of a crack which could lead to tooth breakage; for this reason, such a pit shall be considered unacceptable (for example, in aerospace transmissions).

Similar considerations should be taken into account in respect of turbine gears. In general, during the long life (10^{10} to 10^{11} cycles) demanded of these gears, neither pitting nor unduly severe wear should be considered acceptable as such damage could lead to unacceptable vibrations and excessive dynamic loads. Appropriately generous safety factors should be included in the calculation: only a low probability of failure shall be tolerated.

In contrast, pitting on the operating flanks may be tolerated for some slow speed industrial gears with large teeth (e.g. module 25) made from low hardness steel, which can safely transmit the rated power for 10 years to 20 years. Individual pits can be up to 20 mm in diameter and 0,8 mm deep. The apparently “destructive pitting”, which occurs during the first two or three years of service, normally slows down. In such cases, the tooth flanks become smoothed and work hardened to the extent of increasing the surface Brinell hardness number by 50 % or more. For such conditions, relatively low safety factors (in some, less than 1) may be chosen, with a correspondingly higher probability of tooth surface damage. However, a high safety factor against tooth breakage shall be chosen.

5.3 General rating procedure

There are two main methods for rating the surface durability of bevel and hypoid gears: method B1 and method B2. They are provided in [Clause 6](#) and [Clause 7](#), while [Clause 8](#) contains those influence factors which are equal for both. Although methods B1 and B2 use the same basis of calculation, the calculation procedure is unique to each method.

With both methods, the capability of a gear tooth to resist pitting shall be determined by the comparison of the following stress values:

- **contact stress** σ_H , based on the geometry of the tooth, the accuracy of its manufacture, the rigidity of the gear blanks, bearings and housing, and the operating torque, expressed by the contact stress formula (see [6.1](#) and [7.1](#));
- **permissible contact stress** σ_{HP} , based on the endurance limit for contact stress, $\sigma_{H,lim}$, and the effect of the operating conditions under which the gears operate, expressed by the permissible contact stress Formulae (14) and (22) (see [6.2](#) and [7.2](#)).

The ratio of the permissible contact stress and the calculated contact stress is the safety factor S_H . The value of the minimum safety factor for contact stress, $S_{H,min}$, should be 1,0. For further recommendations on the choice of this safety factor and other minimum values, see ISO 10300-1.

It is recommended that the gear designer and customer agree on the value of the minimum safety factor.

6 Gear flank rating formulae — Method B1

6.1 Contact stress formula

The calculation of pitting resistance is based on the contact (Hertzian) stress, in which the load is distributed along the lines of contact (see ISO 10300-1:2014, Annex A). Calculations are to be carried out for pinion and wheel together; however, in case of hypoid gears separately for drive (suffix D) and coast side flank (suffix C):

$$\sigma_{H-B1} = \sigma_{H0-B1} \sqrt{K_A K_V K_{H\beta} K_{H\alpha}} \leq \sigma_{HP-B1} \quad (1)$$

with load factors K_A , K_V , $K_{H\beta}$, $K_{H\alpha}$ as specified in ISO 10300-1.

The nominal value of the contact stress is given by:

$$\sigma_{H0-B1} = \sqrt{\frac{F_n}{l_{bm}\rho_{rel}}} Z_{M-B} Z_{LS} Z_E Z_K \quad (2)$$

where F_n is the nominal normal force of the virtual cylindrical gear at mean point P:

$$F_n = \frac{F_{mt1}}{\cos\alpha_n \cos\beta_{m1}} \quad (3)$$

with

$\alpha_n = \alpha_{nD}$ = generated pressure angle for drive side in accordance with ISO 23509;

$\alpha_n = \alpha_{nC}$ = generated pressure angle for coast side in accordance with ISO 23509;

l_{bm} is the length of contact line in the middle of the zone of action as specified in ISO 10300-1:2014, A.2.7;

ρ_{rel} is the radius of relative curvature vertical to the contact line as specified in ISO 10300-1:2014, A.2.8;

Z_{M-B} is the mid-zone factor which accounts for the conversion of the contact stress determined at the mean point to the determinant position (see [6.4.1](#));

Z_{LS} is the load sharing factor that considers the load sharing between two or more pairs of teeth (see [6.4.2](#));

Z_E is the elasticity factor which accounts for the influence of the material's E-Module and Poisson's ratio (see [8.1](#));

Z_K is the bevel gear factor which accounts for the influence of the bevel gear geometry (see [6.4.3](#)).

The determinant position of load application is:

- a) the inner point of single tooth contact, if $\varepsilon_{v\beta} = 0$;
- b) the midpoint of the zone of action, if $\varepsilon_{v\beta} \geq 1$;
- c) interpolation between a) and b), if $0 < \varepsilon_{v\beta} < 1$.

6.2 Permissible contact stress

The permissible contact stress shall be calculated separately for pinion (suffix 1) and wheel (suffix 2):

$$\sigma_{\text{HP-B1}} = \sigma_{\text{H,lim}} Z_{\text{NT}} Z_{\text{X}} Z_{\text{L}} Z_{\text{v}} Z_{\text{R}} Z_{\text{W}} Z_{\text{Hyp}} \quad (4)$$

where

- $\sigma_{\text{H,lim}}$ is the allowable stress number (contact), which accounts for material, heat treatment, and surface influence at test gear dimensions as specified in ISO 6336-5;
- Z_{NT} is the life factor (see 8.4), which accounts for the influence of required numbers of cycles of operation;
- Z_{X} is the size factor (see 6.5.1), which accounts for the influence of the tooth size, given by the module, on the permissible contact stress;
- $Z_{\text{L}}, Z_{\text{v}}, Z_{\text{R}}$ are the lubricant film factors (see 8.2) for the influence of the lubrication conditions;
- Z_{W} is the work hardening factor (see 8.3), which considers the hardening of a softer wheel running with a surface-hardened pinion;
- Z_{Hyp} is the hypoid factor (see 6.5.2), which accounts for the influence of lengthwise sliding onto the surface durability.

6.3 Calculated safety factor for contact stress

The calculated safety factor for contact stress shall be checked separately for pinion and wheel, if the values of permissible contact stress are different:

$$S_{\text{H-B1}} = \frac{\sigma_{\text{HP-B1}}}{\sigma_{\text{H-B1}}} > S_{\text{H,min}} \quad (5)$$

where $S_{\text{H,min}}$ is the minimum safety factor; see 5.2 of ISO 10300-1:2014 for recommended numerical values for the minimum safety factor or the risk of failure (damage probability).

NOTE Formula (5) defines the relationship of the calculated safety factor, S_{H} , with respect to contact stress. A safety factor related to the transferable torque is equal to the square of S_{H} .

6.4 Contact stress factors

6.4.1 Mid-zone factor, $Z_{\text{M-B}}$

The mid-zone factor, $Z_{\text{M-B}}$, considers the difference between the radius of relative curvature ρ_{rel} at the mean point and at the critical point of load application of the pinion. The radius ρ_{rel} at the mean point P can directly be calculated from the data of the bevel gears in mesh (see ISO 10300-1:2014, Annex A). For the conversion to the critical point of mesh, the corresponding virtual cylindrical gears are used. Depending on the face contact ratio it can be the inner point of single contact B of the pinion ($\varepsilon_{\text{v}\beta} = 0$) or point M in the middle of the path of contact ($\varepsilon_{\text{v}\beta} \geq 1$) or a point interpolated between B and M for $0 < \varepsilon_{\text{v}\beta} < 1$ (see Figure 1). The comparison with the results of tooth contact analyses shows a good approximation for bevel gear as well as for hypoid gear sets.

ATTENTION — For hypoid gears, the mid-zone factor should be determined for both, drive and coast flank, separately.

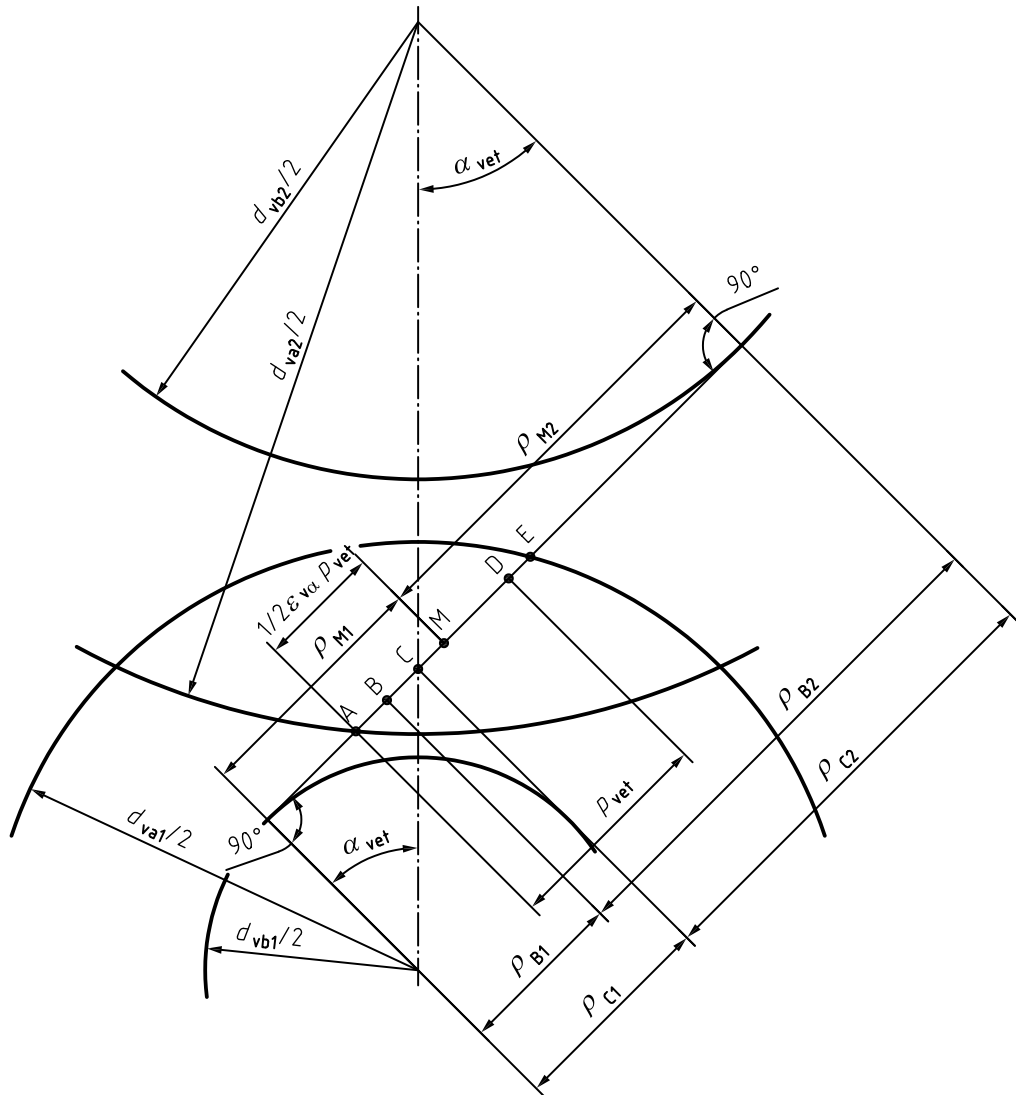

The schematic view of a cylindrical gear set in transverse section shows the line of action being tangent to both base circles d_{vb1} and d_{vb2} of pinion and wheel. The tip circles d_{va2} and d_{va1} intersect the line of action in points A and E, which define the path of contact. In between there are pitch point C, midpoint M and inner point of single contact B, for which different radii of profile curvature are specified: $\rho_{C1,2}$, $\rho_{M1,2}$, $\rho_{B1,2}$, the basis for Formula (6)

Figure 1 — Radii of curvature at midpoint M and inner point of single contact B of the pinion for determination of the mid-zone factor, Z_{M-B}

The mid-zone factor, Z_{M-B} , is calculated by Formula (6):

$$Z_{M-B} = \frac{\tan \alpha_{vet}}{\sqrt{\left[\sqrt{\left(\frac{d_{va1}}{d_{vb1}} \right)^2 - 1} - F_1 \frac{\pi}{z_{v1}} \right] \cdot \left[\sqrt{\left(\frac{d_{va2}}{d_{vb2}} \right)^2 - 1} - F_2 \frac{\pi}{z_{v2}} \right]}} \quad (6)$$

The auxiliary factors F_1 and F_2 for the mid-zone factor are given in [Table 2](#).

Table 2 — Factors for calculation of mid-zone factor, Z_{M-B}

Parameters	F_1	F_2
$\varepsilon_{v\beta} = 0$	2	$2 (\varepsilon_{v\alpha} - 1)$
$0 < \varepsilon_{v\beta} < 1$	$2 + (\varepsilon_{v\alpha} - 2) \varepsilon_{v\beta}$	$2 \varepsilon_{v\alpha} - 2 + (2 - \varepsilon_{v\alpha}) \varepsilon_{v\beta}$
$\varepsilon_{v\beta} \geq 1$	$\varepsilon_{v\alpha}$	$\varepsilon_{v\alpha}$

6.4.2 Load sharing factor, Z_{LS}

The load sharing factor, Z_{LS} , accounts for load sharing between two or more pairs of teeth. That means this factor determines the maximum portion of the total load which affects one tooth. The load distribution along each contact line in the zone of action is assumed to be elliptical. The area, A , of each semi-ellipse (see Figure 2) represents the load on the respective contact line, and the sum of all areas over all contact lines being simultaneously in mesh, represents the total load on the gear set. Additionally, the distribution of the peak loads, p , over the line of action is assumed to follow a parabola (exponent e). On this basis, the maximum load over the middle contact line divided by the total load is a measure for load sharing.

NOTE In this context, contact line means the major axis of the Hertzian contact ellipse under load.

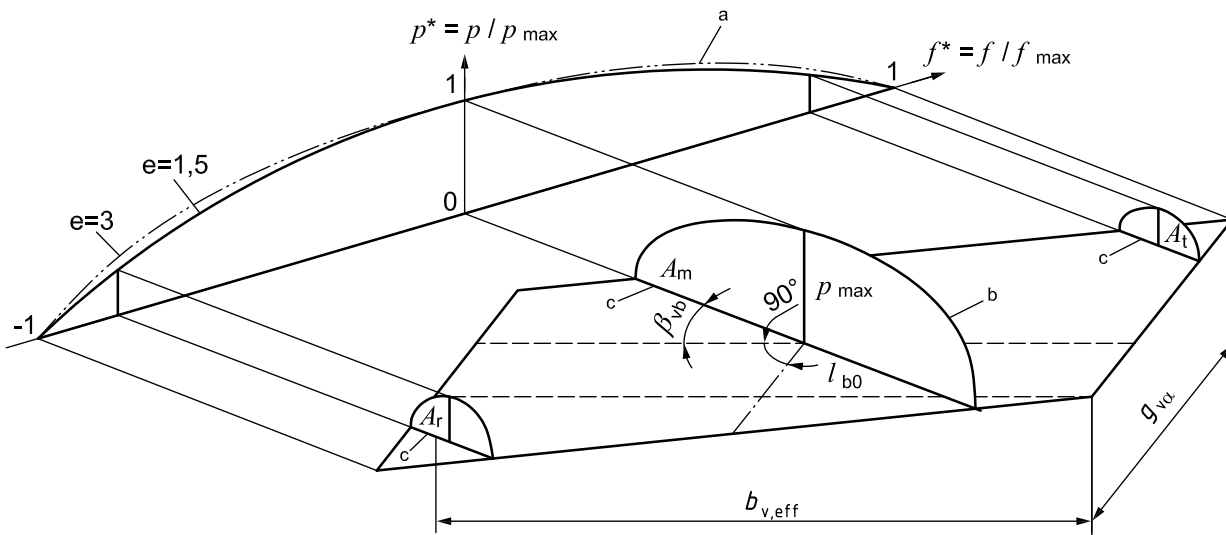

Key

- a Parabolic distribution of peak loads.
- b Elliptical load distribution.
- c Contact lines simultaneously in mesh.

Figure 2 — Load distribution in the contact area

For easier calculation, dimensionless parameters related to their maximum values are used (marked by *) for the peak load, p , and the distance, f , of the relevant contact line from the centre of the zone of action.

Related peak load p^* is given by:

$$p^* = \frac{p}{p_{\max}} = 1 - \left(\frac{|f|}{|f_{\max}|} \right)^e = 1 - |f^*|^e \tag{7}$$

with f given in Table A.2 of ISO 10300-1:2014, and exponent, e , given in Table 3.

The related area, A^* , is calculated by the formula of an ellipse whose major axis is half the length of the contact line l_b and whose minor axis is given by the related peak load p^* :

Related area A^* :

$$A^* = \frac{1}{4} p^* l_b \pi \quad (8)$$

with l_b in accordance with A.2.7 of ISO 10300-1:2014.

Table 3 — Exponent e for calculation of parabolic distribution of peak loads, p^*

Profile crowning	Exponent e
low (e.g. automotive gears)	3
high (e.g. industrial gears)	1,5

The ratio, V , of maximum load over the middle contact line and total load can be expressed by:

$$V = \frac{A_m^*}{A_t^* + A_m^* + A_r^*} \quad (9)$$

As the contact stress is a function of the square root of load, this is necessarily also applied to the ratio of the maximum load and the total load, when determining the load sharing factor Z_{LS} :

$$Z_{LS} = \sqrt{\frac{A_m^*}{A_t^* + A_m^* + A_r^*}} \quad (10)$$

where

A_t^* is the area above the tip contact line,

where p^* , l_b shall be calculated with f_t according to ISO 10300-1:2014, Table A.2;

A_m^* is the area above the middle contact line,

where p^* , l_b shall be calculated with f_m in accordance with ISO 10300-1:2014, Table A.2;

A_r^* is the area above the root contact line,

where p^* , l_b shall be calculated with f_r in accordance with ISO 10300-1:2014, Table A.2.

6.4.3 Bevel gear factor, Z_K

The factor Z_K is an empirical factor which accounts for the differences between cylindrical and bevel gears in such a way as to agree with practical experience. It is a stress adjustment constant which permits the rating of bevel gears, using the same allowable contact stress numbers as for cylindrical gears.

A reasonable approximation for Z_K is given in Formula (11):

$$Z_K = 0,85 \quad (11)$$

6.5 Permissible contact stress factors

6.5.1 Size factor, Z_X

Factor Z_X accounts for statistical evidence indicating that the stress levels, at which fatigue damage occurs, decreases with an increase in component size. This results from the influence of lower stress gradients on subsurface defects (theoretical stress analysis) and of gear size on material quality (effect on forging process, variations in structure, etc.). The main influence parameters related to the size factor are:

- a) material quality (furnace charge, cleanliness, forging);
- b) heat treatment, distribution of hardening;
- c) module in the case of surface hardening; depth of hardened layer relative to the size of teeth (core-supporting effect).

The size factor, Z_X , shall be determined separately for pinion and wheel. However, reasonable size factors for gear teeth have not yet been established. So, in this clause (i.e. Clause 6 on gear flank rating formulae: method B1), the size factor is set equal to unity ($Z_{X1,2} = 1$) for most gears, provided a proper choice of material is made.

6.5.2 Hypoid factor, Z_{Hyp}

6.5.2.1 General

Tests were carried out on series of bevel gears with increasing relative hypoid offset values a_{rel} . They show that the permanent transmissible torque increases from zero offset to typical offset values, but decreases again at very high offset values. The Hertzian pressure caused by the respective permanent transmissible torque has its maximum on bevel gears without offset; however, this pressure decreases immediately with increasing offset. The only interpretation seems to be that higher sliding velocities lower the allowable contact stresses on the flank. Rising contact temperatures and debasing lubricant film developments are regarded as main reasons for this lowering effect.

In order to realize this effect, different components of velocities in the mean point have to be considered: The sliding velocity parallel to the contact line, $v_{g,par}$, which is unfavourable for the temperature and the oil film thickness, and the sum of velocities vertical to the contact line, $v_{\Sigma,vert}$, which is advantageous for the oil film. For bevel gears without offset, $v_{g,par}$ is negligably small compared to $v_{\Sigma,vert}$, while for hypoid gears, both components increase with the offset value, but $v_{g,par}$ more than $v_{\Sigma,vert}$. So, the ratio of both components is an indicator for the different temperature and oil film behaviour of hypoid gears in comparison to cylindrical gears and bevel gears without offset. To consider this effect in the rating formula for surface durability the hypoid factor, Z_{Hyp} , is included in method B1.

NOTE In this context, contact line means the major axis of the Hertzian contact ellipse under load.

The following empirical equation for the hypoid factor, Z_{Hyp} , was derived from test results:

$$Z_{Hyp} = 1 - 0,3 \left(\frac{v_{g,par}}{v_{\Sigma,vert}} - 0,15 \right) \quad (12)$$

where

the range of validity is given by: $0,6 \leq Z_{Hyp} \leq 1,0$; for bevel gears without offset, $Z_{Hyp} = 1,0$;

$v_{g,par}$ is the sliding velocity parallel to the contact line;

$v_{\Sigma,vert}$ is the sum of velocities vertical to the contact line.

In order to evaluate the different velocities, [Figure 3](#) shows both tangential velocities v_{mt1} and v_{mt2} as well as the sliding velocity, v_g , for a hypoid gear pair with $\Sigma < 90^\circ$:

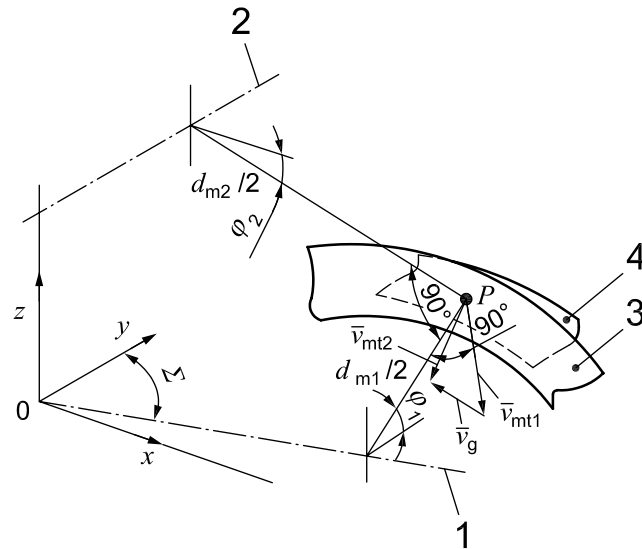

Key

- 1 pinion axis
- 2 wheel axis
- 3 pinion flank
- 4 wheel flank

Figure 3 — Tangential velocities in the mean point P

6.5.2.2 Sliding velocity

The sliding velocity parallel to the contact line, as shown in [Figure 4](#), is derived from:

$$v_g = v_{mt1} \cos\beta_{m1} (\tan\beta_{m1} - \tan\beta_{m2}) \quad (13)$$

$$v_{g \text{ par}} = v_g \cos|\beta_B| \quad (14)$$

where

v_g is the sliding velocity in the mean point P;

β_B is the inclination angle of contact line as specified in ISO 10300-1:2014, Formula (A.36).

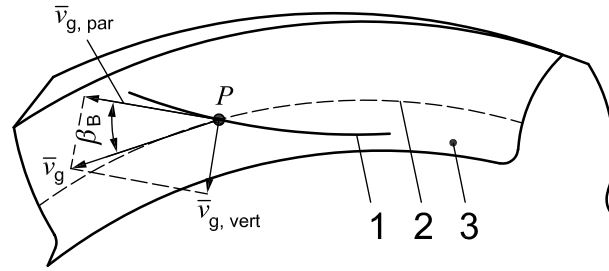

Key

- 1 contact line
- 2 trace of pitch cone
- 3 pinion flank

Figure 4 — Sliding velocity vertical and parallel to the contact line in the mean point P

6.5.2.3 Sum of velocities

The sum of velocities in profile direction is:

$$v_{\Sigma h} = |2 v_{mt1} \cos \beta_{m1} \sin \alpha_n| \quad (15)$$

with $\alpha_n = \alpha_{nD}$ generated pressure angle for drive side (see ISO 23509);

$\alpha_n = \alpha_{nC}$ generated pressure angle for coast side (see ISO 23509).

The sum of velocities in the lengthwise direction is:

$$v_{\Sigma l} = \left| v_{mt1} \left(\sin \beta_{m1} + \frac{\sin \beta_{m2} \cos \beta_{m1}}{\cos \beta_{m2}} \right) \right| \quad (16)$$

According to [Figure 5](#), the sum of velocities results from:

$$v_{\Sigma} = \sqrt{v_{\Sigma h}^2 + v_{\Sigma l}^2} \quad (17)$$

the inclination angle of the sum of velocities vector from:

$$\omega_{\Sigma} = \left| \arctan \left(\frac{v_{\Sigma h}}{v_{\Sigma l}} \right) \right| \quad (18)$$

the sum of velocities vertical to the contact line derives from:

$$v_{\Sigma,vert} = v_{\Sigma} \sin (\omega_{\Sigma} + |\beta_B|) \quad (19)$$

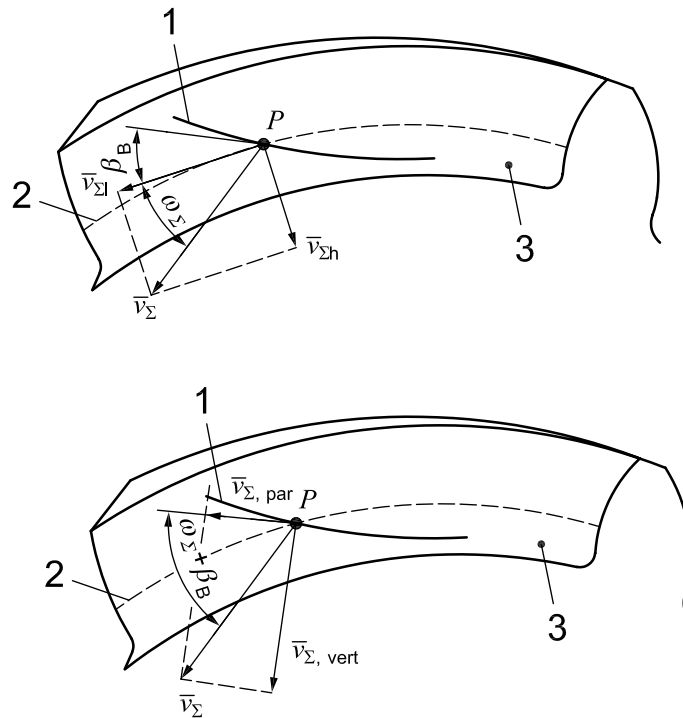

Key

- 1 contact line
- 2 trace of pitch cone
- 3 pinion flank

Figure 5 — Sum of velocities vertical and parallel to the contact line in the mean point P

7 Gear flank rating formulae — Method B2

7.1 Contact stress formula

Calculations are to be carried out for pinion and wheel together; in case of hypoid gears, generally only the drive side is considered:

$$\sigma_{H-B2} = \sigma_{H0-B2} \sqrt{K_A K_v K_{H\beta}} \cdot Z_A \leq \sigma_{HP-B2} \quad (20)$$

where

the load factors K_A , K_v and $K_{H\beta}$ are specified in ISO 10300-1;

Z_A is the contact stress adjustment factor (see 7.4.4).

The nominal value of the contact stress is:

$$\sigma_{H0-B2} = \sqrt{\frac{F_{mt1} d_{m1} Z_{FW}}{b_2 Z_I} \left(\frac{z_2}{d_{e2} Z_1} \right)^2} \cdot Z_E \quad (21)$$

where

- F_{mt1} is the nominal tangential force of the pinion (see ISO 10300-1:2014, Clause 6);
- d_{m1} is the mean pitch diameter of the pinion;
- Z_{FW} is the face width factor (see 7.4.3);
- d_{e2} is the outer pitch diameter of the wheel;
- b_2 is the face width of the wheel;
- $z_{1,2}$ is the number of teeth of pinion and wheel;
- Z_I is the pitting resistance geometry factor (see 7.4.2);
- Z_E is the elasticity factor (see 8.1).

7.2 Permissible contact stress

The permissible contact stress is calculated separately for pinion (suffix 1) and wheel (suffix 2):

$$\sigma_{HP-B2} = \sigma_{H,lim} Z_{NT} Z_L Z_v Z_R Z_W \quad (22)$$

where

- $\sigma_{H,lim}$ is the allowable stress number (contact), which accounts for material, heat treatment, and surface influence at test gear dimensions as specified in ISO 6336-5;
- Z_{NT} is the life factor, which accounts for the influence of required numbers of cycles of operation (see 8.4);
- Z_L, Z_v, Z_R are the lubricant film factors (see 8.2) for the influence of the lubrication conditions;
- Z_W is the work hardening factor (see 8.3), which considers less hardening of the softer wheel running with a surface hardened pinion.

7.3 Calculated safety factor for contact stress

The calculated safety factor for contact stress shall be checked separately for pinion and wheel, if the values of permissible contact stress are different:

$$S_{H-B2} = \frac{\sigma_{HP-B2}}{\sigma_{H-B2}} > S_{H,min} \quad (23)$$

where $S_{H,lim}$ is the minimum safety factor; for recommended values, see 5.2 of ISO 10300-1:2014.

NOTE Formula (23) defines the calculated safety factor S_H with respect to contact stress. A safety factor related to the transferable torque is equal to the square of S_H .

7.4 Contact stress factors

7.4.1 General

Attention — In 7.4, a base unit of one diametral pitch, $1,0/m_{et2}$, is used in the formulae.

7.4.2 Pitting resistance geometry factor, Z_I

7.4.2.1 General

The geometry factor evaluates the relative radius of curvature of the mating tooth flanks and the load sharing between adjacent pairs of teeth at that point on the tooth surfaces where the calculated contact pressure reaches its maximum value. The formulae in 7.4.2.2 and 7.4.2.3 should be used; see ISO 10300-1:2014, B.2. Because of the complexity of the calculation, computerization is recommended.

ANSI/AGMA 2003-C10[5] provides graphs for bevel gears that may be used to determine the geometry factor, Z_I , whenever the gear parameters correspond to those in the graphs. Corresponding graphs for hypoid gears may be taken from AGMA 932-A05.[6]

7.4.2.2 Initial formulae

The angle between contact direction and tooth tangent in pitch plane:

$$\cot(\beta_{m1} - \lambda_1) = \frac{\cos \zeta_R}{\cos \beta_{m1} \cos \beta_{m2} \tan(\beta_{m1} - \lambda_r)} - \tan \beta_{m2} \quad (24)$$

with $(\beta_{m1} - \lambda_r)$ as specified in ISO 10300-1:2014, Formula (B.13).

The angle between projection of pinion axis and direction of contact in pitch plane is given by:

$$\lambda_1 = \beta_{m1} - (\beta_{m1} - \lambda_1) \quad (25)$$

with $(\beta_{m1} - \lambda_1)$ as defined in Formula (24).

The angle of contact line relative to the root cone is given by:

$$\tan w = \frac{\sin \alpha_a \tan(\beta_{m1} - \lambda_r)}{\cos \alpha_{lim}} \quad (26)$$

with α_a = adjusted pressure angle, see ISO 10300-1:2014, Formula (B.14).

Mean base spiral angle:

$$\cos\beta_{bm} = \frac{1,0}{\sqrt{\tan^2(\beta_{m1} - \lambda_r) \cos^2\alpha_a + 1,0}} \quad (27)$$

Relative mean normal base pitch:

$$p_{nb} = \frac{\pi m_{mn} \cos\alpha_a \cos\beta_{bm}}{m_{et2} \cos(\beta_{m1} - \lambda_r)} \quad (28)$$

The angle between projection of wheel axis and direction of contact in pitch plane is given by:

$$\lambda_2 = (\beta_{m1} - \lambda_r) - \beta_{m2} \quad (29)$$

Relative base face width:

$$b_b = \frac{b_2}{m_{et2} \cos\lambda_2} \quad (30)$$

Pressure angle at point of load application:

$$\cos\alpha_{L1,2} = \cos\alpha_a \left[1,0 - \frac{(r_{va1,2} - r_{vn1,2}) \cos^2\beta_{m1,2}}{r_{va1,2} - r_{vn1,2} + R_{mpt1,2}} \right] \quad (31)$$

Radius of curvature difference between point of load application and mean point:

$$\rho_{\Delta1,2} = \frac{r_{va1,2} - r_{vn1,2} + R_{mpt1,2}}{\cos^2\beta_{m1,2}} \cos\alpha_{L1,2} (\tan\alpha_{L1,2} - \tan\alpha_a) \quad (32)$$

Radius of curvature change:

$$\rho_{\Delta red} = \cos\beta_{bm} (\rho_{\Delta1} + \rho_{\Delta2}) \quad (33)$$

Relative length of action within the contact ellipse is given by:

$$g_\eta = \sqrt{\rho_{\Delta red}^2 \cos^2\beta_{bm} + b_b^2 \sin^2\beta_{bm}} \quad (34)$$

7.4.2.3 Radius of relative profile curvature, ρ_0 , and load sharing ratio at critical point, ϵ_{NI}

The critical point on the tooth surface occurs when the contact line passes through a point at a distance, y_I , from the midpoint of the length of action. The value of y_I is chosen to produce the minimum value of Z_I which corresponds to the point of maximum contact stress.

- a) For straight bevel and Zerol bevel gears, the contact line passes close to the lowest point of single tooth contact on the pinion, in which case:

$$y_I = 0,5g_{van} - p_{nb} \quad (35)$$

In this case, the geometry factor, Z_I , is calculated using Formulae (36) to (45) without iteration.

- b) For spiral bevel and hypoid gears, it is necessary to start an iteration procedure:

As initial value $y_I = 0$ is assumed and Z_I is calculated using Formulae (36) to (45).

Length of action at critical point in contact ellipse:

$$g_{\eta l} = \sqrt{g_{\eta}^2 - 4,0y_l^2} \quad (36)$$

Length of action considering adjacent teeth:

$$\begin{aligned} g_{\eta l \Sigma}^3 = & g_{\eta l}^3 + \sqrt{[g_{\eta l}^2 - 4,0p_{nb}(p_{nb} + 2,0y_l)]^3} + \sqrt{[g_{\eta l}^2 - 4,0p_{nb}(p_{nb} - 2,0y_l)]^3} \\ & + \sqrt{[g_{\eta l}^2 - 8,0p_{nb}(2,0p_{nb} + 2,0y_l)]^3} + \sqrt{[g_{\eta l}^2 - 8,0p_{nb}(2,0p_{nb} - 2,0y_l)]^3} \\ & + \sqrt{[g_{\eta l}^2 - 16,0p_{nb}(4,0p_{nb} + 2,0y_l)]^3} + \sqrt{[g_{\eta l}^2 - 16,0p_{nb}(4,0p_{nb} - 2,0y_l)]^3} \end{aligned} \quad (37)$$

Note, in Formula (37), if any square root term is negative, it shall be set to zero.

Load sharing ratio:

$$\varepsilon_{NI} = g_{\eta l}^3 / g_{\eta l \Sigma}^3 \quad (38)$$

Length of contact line:

$$g_c = g_{\eta l} \rho_{\Delta red} y_l / g_{\eta}^2 \quad (39)$$

Position change along path of contact:

$$g_{\eta \Delta} = \frac{\rho_{\Delta red}^2 y_l}{g_{\eta}^2} + k' g_c \tan \beta_{bm} + \frac{0,5 \rho_{\Delta red}}{\cos \beta_{bm}} - \rho_{\Delta 2} \quad (40)$$

where k' is the contact shift factor as specified in ISO 10300-1:2014, B.5.

Intermediate value:

$$X = \frac{\sin^2 w \cos \alpha_{lim} \cos(\zeta_R - \lambda_1) \cos \lambda_1}{\sin^2(\beta_{m1} - \lambda_1) \sin \alpha_a \cos \zeta_R} \quad (41)$$

Profile radius of curvature:

$$\rho_{1,2} = R_{mpt1,2} X \pm g_{\eta \Delta} \quad (42)$$

Relative radius of profile curvature between pinion and wheel:

$$\rho_t = \frac{\rho_1 \rho_2}{\rho_1 + \rho_2} \quad (43)$$

The inertia factor, Z_i , is determined depending on the modified contact ratio, $\varepsilon_{v\gamma}$:

a) for $\varepsilon_{v\gamma} \leq 2,0$:

$$Z_i = 2,0 / \varepsilon_{v\gamma} \quad (44a)$$

b) for $\varepsilon_{v\gamma} > 2,0$:

$$Z_i = 1,0 \quad (44b)$$

Pitting resistance geometry factor:

$$Z_I = \frac{g_c \rho_t \cos \alpha_a m_{mn}}{b_b z_1 Z_i \varepsilon_{NI} m_{et2}} \quad (45)$$

Formulae (36) to (45) shall be recalculated by stepping y_I in both directions until a minimum of Z_I is found.

End of iteration

7.4.3 Face width factor, Z_{FW}

The face width factor, Z_{FW} (see [Figure 6](#)), reflecting non-uniformity of material properties, depends primarily on:

- tooth size (diameter of part);
- ratio of tooth size to diameter of part;
- face width;
- area of stress pattern;
- material characteristics.

Although the face width factor is a function of the strength of the material and therefore should appear in the equations for permissible stress, it is more practicable to include it in the equations for calculated stress as is done in method B2. Then, it is possible to prepare S-N-diagrams from experimental data using a wide range of gears with varying tooth sizes. Otherwise, one would be limited to using gears of only one tooth size. The face width factor for pitting resistance of bevel gears, without sufficient experience, is determined as a size factor being dependent on the face width:

a) for $b_2 < 12,7$ mm:

$$Z_{FW} = 0,5 \quad (46a)$$

b) for $12,7 \leq b_2 \leq 79,8$ mm:

$$Z_{FW} = 0,004\ 92b_2 + 0,4375 \quad (46b)$$

c) for $b_2 > 79,8$ mm:

$$Z_{FW} = 0,83 \quad (46c)$$

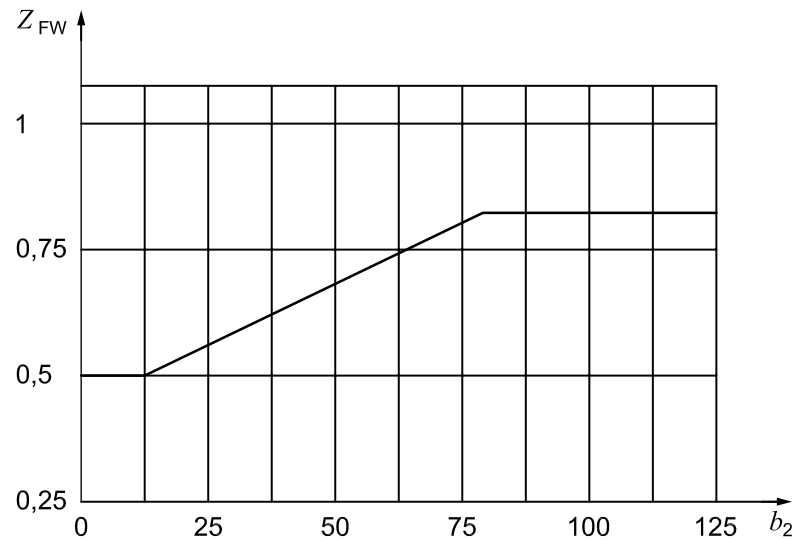

Key

b_2 wheel face width (mm)

Z_{FW} face width factor (-)

Figure 6 — Face width factor, Z_{FW}

7.4.4 Contact stress adjustment factor, Z_A

The contact stress adjustment factor Z_A , adjusts the calculation results of method B2 so that the contact stress numbers in ISO 6336-5 can be used. The determination of Z_A is based on the comparison of ISO 6336-5 MQ grade carburized case hardened steel which has an allowable stress number of 1 500 N/mm², to the equivalent ANSI/AGMA 2003-C10[5] grade 2 case hardened steel, which has an allowable stress number of 1 550 N/mm².

Hence it follows for carburized case hardened steel that:

$$Z_A = 0,967 \quad (47)$$

For other specific materials and qualities, Z_A shall be calculated by taking the ratio of the allowable contact stress number in ISO 6336-5 to equivalent ANSI/AGMA 2003-C10[5] steel.

8 Factors for contact stress and permissible contact stress common for method B1 and method B2

8.1 Elasticity factor, Z_E

The elasticity factor, Z_E , accounts for the influence of the material specific quantities E (modulus of elasticity) and ν (Poisson's ratio) on the contact stress.

$$Z_E = \sqrt{\frac{1}{\pi \left(\frac{(1-\nu_1^2)}{E_1} + \frac{(1-\nu_2^2)}{E_2} \right)}} \quad (48)$$

For $E_1 = E_2 = E$ and $\nu_1 = \nu_2 = \nu$, Formula (49) applies:

$$Z_E = \sqrt{\frac{E}{2\pi(1-\nu_1^2)}} \quad (49)$$

For steel and light metal $\nu = 0,3$ and thus:

$$Z_E = \sqrt{0,175 E} \quad (50)$$

For a steel on steel gear pair:

$$Z_E = 189,8 \text{ (N/mm}^2\text{)}^{1/2} \quad (51)$$

If a pair of gears is made from materials having modules of elasticity, E_1 and E_2 , E should be determined by:

$$E = \frac{2E_1 E_2}{E_1 + E_2} \quad (52)$$

For Z_E of some other gear pair materials, see ISO 6336-2.[\[1\]](#)

8.2 Lubricant film influence factors, Z_L , Z_V , Z_R

8.2.1 General

The influences on the lubricant film between the tooth flanks are approximated by the factors Z_L (oil viscosity), Z_V (tangential speed) and Z_R (flank roughness). [Figures 7 to 9](#) show the ranges of these three influence factors. In addition, the scattering (spread of values) indicates that there are other factors besides the three, not accounted for in the assumptions.

NOTE For additional general remarks about these three factors, see ISO 6336-2.[\[1\]](#)

8.2.2 Restrictions

When there are no comprehensive experiences or test results (method A), Z_L , Z_V and Z_R shall be determined separately according to method B (see [8.2.3](#)). However, in many cases, in fact for most industrial gears, the shorter method, i.e. method C (see [8.2.4](#)), may be used instead. When a gear pair consists of one member of hard and the other of soft material, Z_L , Z_V and Z_R shall be determined for the softer of the materials.

8.2.3 Method B

8.2.3.1 Lubricant factor, Z_L

Taking into account the restrictions given in 8.2.2, the lubricant factor, Z_L , accounts for the influence of the type of lubricant, and its viscosity, on the surface durability (pitting). In Figure 7, the curves of the lubricant factor, Z_L , are plotted for mineral oils (with or without EP additives) as a function of the nominal viscosity and the value $\sigma_{H,lim}$ of the softer gear of the mating pair. In case of certain synthetic oils, with lower coefficient of friction, larger values of Z_L than those calculated for mineral oils may be used.

ATTENTION — This part of ISO 10300 does not include a recommendation as to the choice of oil viscosity, which shall only be made with reference to testing, experience or gear lubrication publications.

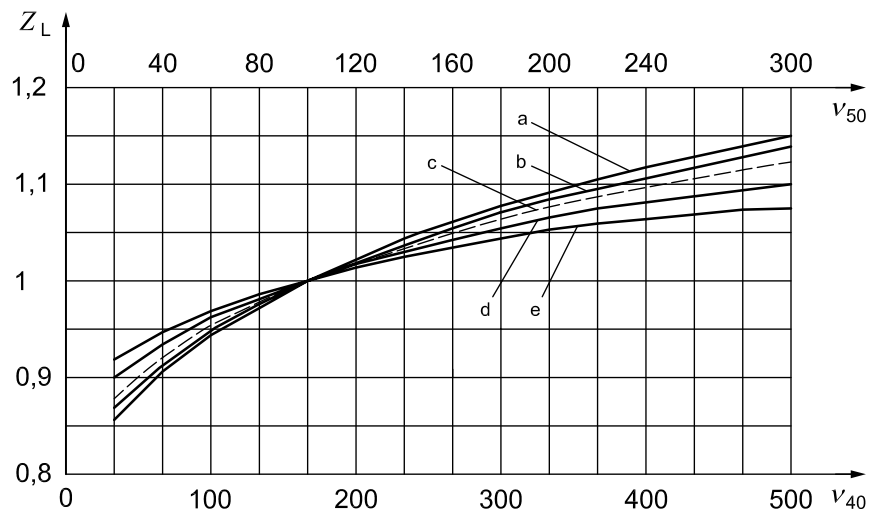

Key

- ν viscosity (mm^2/s), suffix: temperature ($^{\circ}\text{C}$)
- Z_L lubricant factor
- a $\sigma_{H,lim} \leq 850 \text{ N/mm}^2$.
- b $\sigma_{H,lim} = 900 \text{ N/mm}^2$.
- c $\sigma_{H,lim} = 1\,000 \text{ N/mm}^2$.
- d $\sigma_{H,lim} = 1\,100 \text{ N/mm}^2$.
- e $\sigma_{H,lim} \geq 1\,200 \text{ N/mm}^2$.

Figure 7 — Lubricant factor, Z_L , for mineral oils

Z_L should be calculated using Formulae (53) and (54), which represent the course of the curves in Figure 7:

$$Z_L = C_{ZL} + \frac{4(1,0 - C_{ZL})}{\left(1,2 + \frac{134}{\nu_{40}}\right)^2} \quad (53)$$

For the range of $\sigma_{H,lim} = 850 \text{ N/mm}^2$ to $\sigma_{H,lim} = 1\,200 \text{ N/mm}^2$, the following applies:

$$C_{ZL} = 0,08 \frac{\sigma_{H,lim} - 850}{350} + 0,83 \quad (54)$$

For $\sigma_{H,lim}$ values below 850 N/mm^2 , the Z_L value for $\sigma_{H,lim} = 850 \text{ N/mm}^2$ is used, while for $\sigma_{H,lim}$ values above $1\,200 \text{ N/mm}^2$, the Z_L value for $\sigma_{H,lim} = 1\,200 \text{ N/mm}^2$ is used.

8.2.3.2 Speed factor, Z_v

Taking into account the restrictions given in 8.2.2, the indicated speed factor, Z_v , accounts for the influence of the tangential speed on the surface durability (pitting). In Figure 8, the curves of the speed factor are plotted as a function of the tangential speed and the value $\sigma_{H,lim}$ of the softer gear of the mating pair.

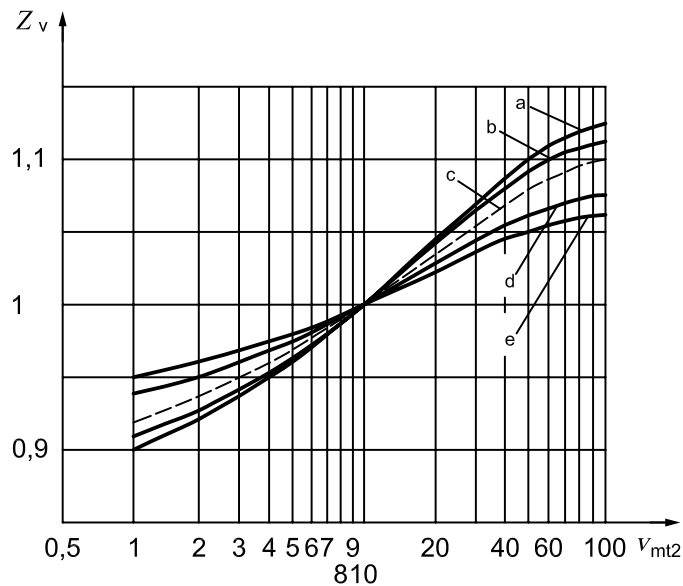

Key

v_{mt2} tangential speed at mid-face of reference cone, wheel (m/s)

Z_v speed factor

- a $\sigma_{H,lim} \leq 850 \text{ N/mm}^2$.
- b $\sigma_{H,lim} = 900 \text{ N/mm}^2$.
- c $\sigma_{H,lim} = 1\,000 \text{ N/mm}^2$.
- d $\sigma_{H,lim} = 1\,100 \text{ N/mm}^2$.
- e $\sigma_{H,lim} \geq 1\,200 \text{ N/mm}^2$.

Figure 8 — Speed factor, Z_v

Z_v should be calculated using Formulae (55) and (56), which represent the course of the curves in Figure 8.

$$Z_v = C_{ZV} + \frac{2(1,0 - C_{ZV})}{\sqrt{0,8 + \frac{32}{v_{mt2}}}} \quad (55)$$

For the range of $\sigma_{H,lim} = 850 \text{ N/mm}^2$ to $\sigma_{H,lim} = 1\,200 \text{ N/mm}^2$, the following applies:

$$C_{ZV} = 0,08 \frac{\sigma_{H,lim} - 850}{350} + 0,85 \quad (56)$$

For $\sigma_{H,lim}$ values below 850 N/mm^2 , the Z_v value for $\sigma_{H,lim} = 850 \text{ N/mm}^2$ is used, while for $\sigma_{H,lim}$ values above $1\,200 \text{ N/mm}^2$, the Z_v value for $\sigma_{H,lim} = 1\,200 \text{ N/mm}^2$ is used.

8.2.3.3 Roughness factor, Z_R

Taking into account the restrictions given in 8.2.2, the indicated roughness factor, Z_R , accounts for the influence of the surface condition of the tooth flanks on the surface durability (pitting). In Figure 9, the curves of the roughness factor are plotted as a function of Rz_{10} and the value $\sigma_{H,lim}$ of the softer gear of

the mating pair. The figure is valid for a gear pair with a radius of relative curvature at the pitch point of $\rho_{rel} = 10$ mm.

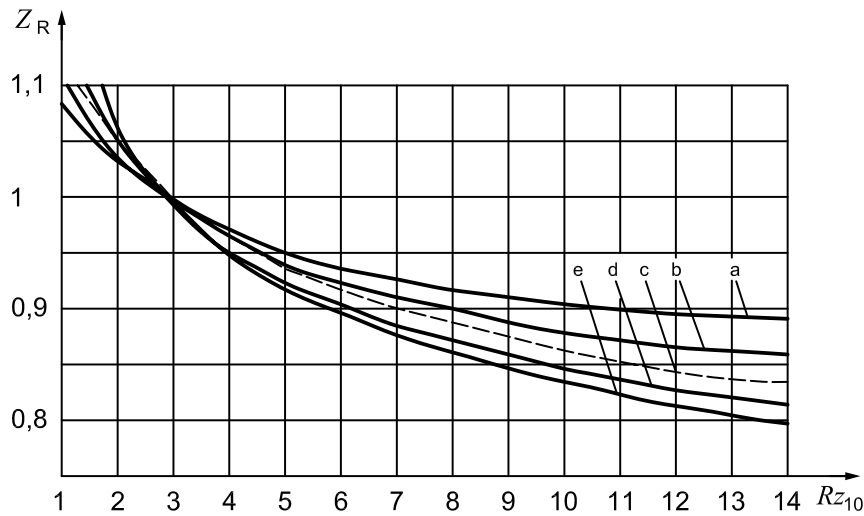

Key

- Rz_{10} roughness (μm)
- Z_R roughness factor
- a $\sigma_{H,lim} \geq 1\,200$ N/mm².
- b $\sigma_{H,lim} = 1\,100$ N/mm².
- c $\sigma_{H,lim} = 1\,000$ N/mm².
- d $\sigma_{H,lim} = 900$ N/mm².
- e $\sigma_{H,lim} \leq 850$ N/mm².

Figure 9 — Roughness factor, Z_R

The mean roughness shall be determined for the values Rz_1 and Rz_2 of the pinion and the wheel after manufacturing. Allowance shall be made for any special surface treatment or running-in process. The roughness measured in the direction of the sliding and rolling movement shall be decisive.

The mean relative roughness is given by:

$$Rz_{10} = \frac{Rz_1 + Rz_2}{2} \cdot \sqrt[3]{\frac{10}{\rho}} \quad (57)$$

with the radius of relative curvature $\rho = \rho_{rel}$ for method B1 (see ISO 10300-1:2014, Annex A), $\rho = \rho_t m_{et2}$ for method B2 [see Formula (43) of this part of ISO 10300].

When the roughness is given as an Ra value (= CLA value, AA value), the following approximation may be used: $Ra = CLA = AA = Rz/6$.

The factor Z_R should be calculated using Formulae (58) and (59), which represent the course of the curves in [Figure 9](#).

Roughness factor:

$$Z_R = \left(\frac{3}{Rz_{10}} \right)^{C_{ZR}} \quad (58)$$

In the range of $850 \text{ N/mm}^2 \leq \sigma_{H,\text{lim}} \leq 1\,200 \text{ N/mm}^2$, the following applies:

$$C_{ZR} = 0,12 + \frac{1\,000 - \sigma_{H,\text{lim}}}{5\,000} \quad (59)$$

For $\sigma_{H,\text{lim}}$ values below 850 N/mm^2 , use $\sigma_{H,\text{lim}} = 850 \text{ N/mm}^2$, while for $\sigma_{H,\text{lim}}$ values above $1\,200 \text{ N/mm}^2$, use $\sigma_{H,\text{lim}} = 1\,200 \text{ N/mm}^2$.

8.2.4 Method C (product of Z_L , Z_V and Z_R)

As a simplification of method B, it is assumed that a proper lubricant viscosity has been chosen for the operating conditions (tangential speed, load, structural size).

The following values apply for the product of Z_L , Z_V and Z_R :

- for through hardened gear pairs without finishing process: 0,85;
- for gear pairs lapped after hardening: 0,92;
- for gear pairs ground after hardening, or for hard cut gear pairs, with:
 - $Rz_{10} \leq 4 \mu\text{m}$: $Z_L Z_V Z_R = 1,0$;
 - $Rz_{10} > 4 \mu\text{m}$: $Z_L Z_V Z_R = 0,92$.

If these conditions do not apply, Z_L , Z_V and Z_R shall be determined separately according to method B.

8.3 Work hardening factor, Z_W

8.3.1 General

The work hardening factor, Z_W , accounts for the increase in surface durability when a structural or through hardened steel wheel is in mesh with a surface hardened pinion which has smooth tooth flanks ($Rz \leq 6 \mu\text{m}$).

NOTE The increase in the surface durability of the soft wheel can depend not only on work hardening, but on other influences, such as polishing (lubricant), alloying elements and internal stresses in the soft material, surface roughness of the hard pinion, contact stress and hardening processes.

8.3.2 Method B

The data provided in this subclause are based on tests of different materials using standard reference test gears as well as on field experience with production gears. The extent of scatter (spread of values) indicates the existence of other influences not included in the calculation process. Although the curve in [Figure 10](#) was carefully chosen, it shall not be interpreted as absolute. It is, like Formula (60), empirical. The value of Z_W is taken as the same for endurance, limited life and static stress.

Z_W may be taken from [Figure 10](#), as a function of the flank hardness of the softer bevel gear.

For method B, Z_W shall be calculated using Formula (60), which is consistent with the curve in [Figure 10](#):

$$Z_W = 1,2 - \frac{HB - 130}{1\,700} \quad (60)$$

where

HB is the Brinell hardness of tooth flanks of the softer gear of the pair;

Z_W is 1,2 for $HB < 130$, and 1,0 for $HB > 470$;

Z_W is 1,0 if pinion and wheel have the same hardness.

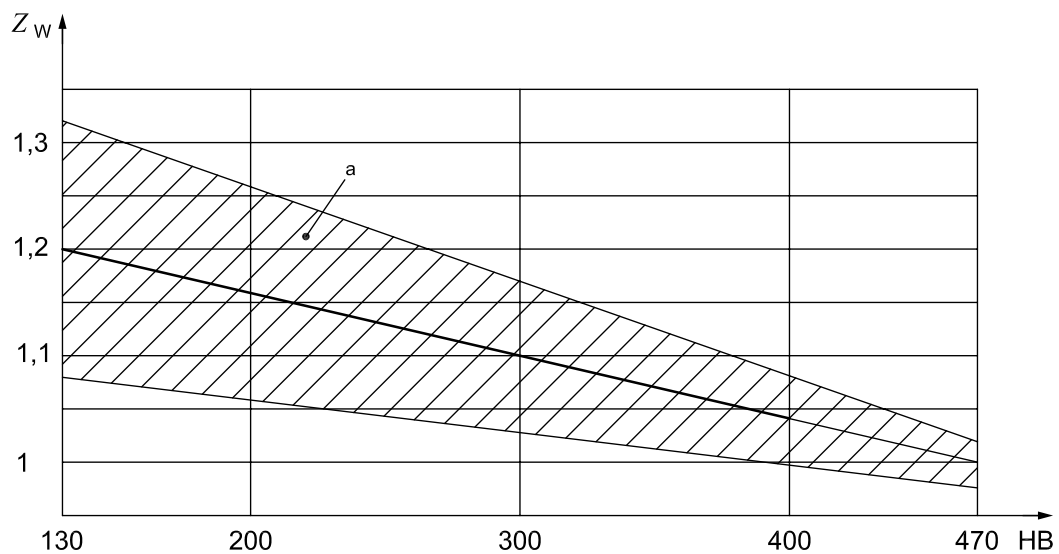

Key

Z_W tooth hardening factor

HB tooth flank hardness of the softer bevel gear of the pair, generally the wheel

a Range of scatter.

Figure 10 — Work hardening factor, Z_W

8.4 Life factor, Z_{NT}

8.4.1 General

The life factor, Z_{NT} , accounts for the higher contact stress, including static stress, which may be acceptable for a limited life (number of load cycles), as compared with the allowable stress at the point or “knee” on the curves of [Figure 11](#) where $Z_{NT} = 1,0$. For extended life, Z_{NT} may be less than 1,0. Z_{NT} has been determined for standard test gear conditions (see ISO 6336-6[2] for further information).

The main influences related to Z_{NT} are:

- material and heat treatment (see [5.2](#), ISO 6336-5);
- number of load cycles (service life), N_L ;
- lubrication regime;
- failure criteria;

- e) required smoothness of operation;
- f) pitch line velocity;
- g) gear material cleanliness;
- h) material ductility and fracture toughness;
- i) residual stress.

For the purposes of this part of ISO 10300, the number of load cycles, N_L , is identified as the number of mesh contacts, under load, of the gear being analysed.

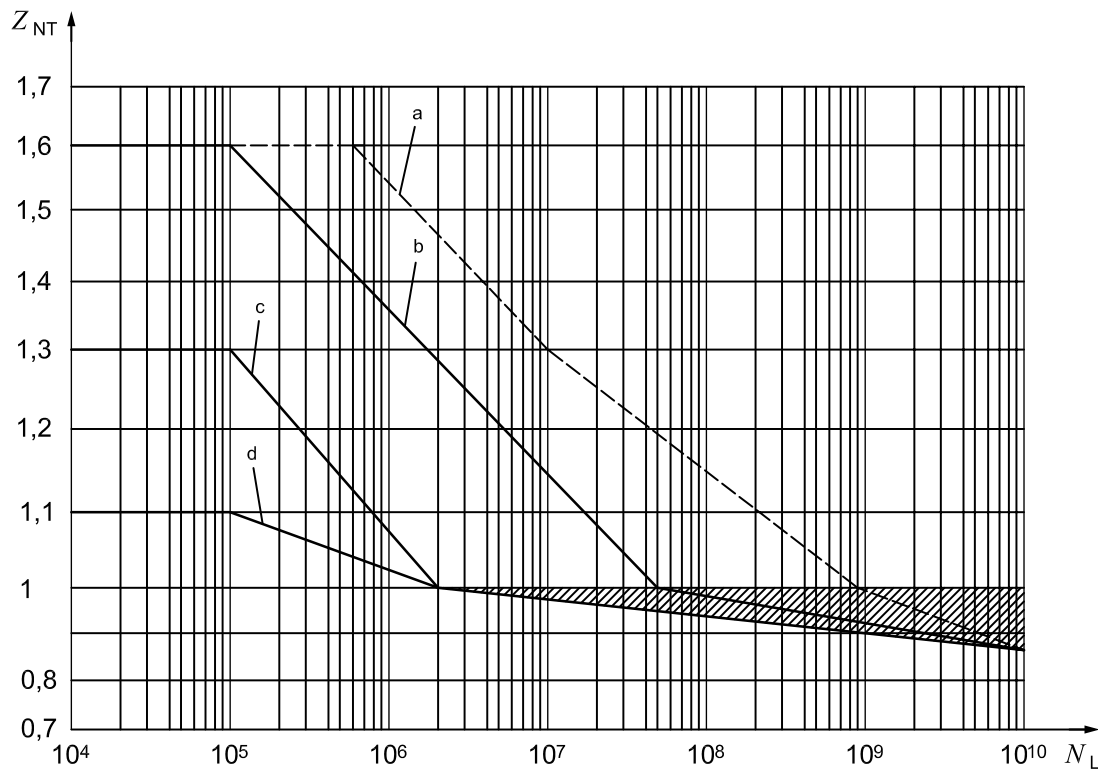

Key

N_L number of load cycles

Z_{NT} life factor

- a St, V, GGG (perl. bain.), GTS (perl.), Eh, IF, when limited pitting permitted.
- b St, V, Eh, IF, GGG (perl. bain.), GTS (perl.).
- c GG, NT (nitr.), GGG (ferr.), NV (nitr.).
- d NV (nitrocar.).

NOTE The abbreviated terms are explained in [Table 1](#).

Figure 11 — Life factor for pitting resistance, Z_{NT}

8.4.2 Method A

The S-N, or damage curve, derived from examples of the actual gear pair, is determinant for load capacity at limited service life. Thus it is also determinant for the materials of both mating gears, heat treatment, relevant diameter, module, surface roughness of tooth flanks, pitch line velocity and lubricant. Since the S-N/damage curve is directly valid for the conditions mentioned, the influences represented by the factors Z_R , Z_V , Z_L , Z_W and Z_X are included in the curve, and should therefore be assigned the value 1,0 in the calculation formulae.

8.4.3 Method B

The permissible stress at limited service life, or the safety factor in the limited life stress range, shall be determined using the life factor, Z_{NT} , for a standard reference test gear (see ISO 6336-5). The factors Z_L , Z_R , Z_V and Z_W are not included. However, the modified effect of these factors on limited life shall be considered. Z_{NT} for static and endurance stresses may be taken from [Figure 11](#) or [Table 4](#), and for limited life stress by interpolation between the values for the endurance and static stresses (see ISO 6336-5).

Table 4 — Life factor, Z_{NT} , for static and endurance stress limits

Material ^a	Number of load cycles, N_L	Life factor, Z_{NT}
St, V ^b , GGG (perl. bain.) ^b GTS (perl.), Eh, IF ^b	$N_L \leq 6 \times 10^5$, static	1,6
	$N_L = 10^7$, endurance	1,3
	$N_L = 10^9$, endurance	1,0
	$N_L = 10^{10}$, endurance	0,85
St, V, GGG (perl. bain.), GTS (perl.), EH, IF	$N_L = 10^5$, static	1,6
	$N_L = 5 \times 10^7$, endurance	1,0
	$N_L = 10^{10}$, endurance	0,85
	Optimum lubrication, material, manufacturing and experience	1,0
GG, GGG (ferr.), NT (nitr.), NV (nitr.)	$N_L = 10^5$, static	1,3
	$N_L = 2 \times 10^6$, endurance	1,0
	$N_L = 10^{10}$, endurance	0,85
	Optimum lubrication, material, manufacturing and experience	1,0
NV (nitrocar.)	$N_L = 10^5$, static	1,1
	$N_L = 2 \times 10^6$, endurance	1,0
	$N_L = 10^{10}$, endurance	0,85
	Optimum lubrication, material, manufacturing and experience	1,0

^a For descriptions of the material abbreviated terms, see [Table 1](#).

^b Only if a certain degree of pitting is acceptable.

Annex A (informative)

Bevel slip factor Z_S — Method B1

The bevel slip factor, Z_S , accounts for the increase of surface durability in the flank zone of positive specific sliding versus the zone of negative specific sliding. It may be used in the calculation of the permissible contact stress, σ_{HP} , for pinion and wheel, instead of the bevel gear factor, Z_K , in the calculation of the contact stress, σ_H .

In this case, the nominal value of contact stress is given by:

$$\sigma_{H0-B1} = \sqrt{\frac{F_n}{l_{bm}\rho_{rel}}} Z_{M-B} Z_{LS} Z_E \quad (A.1)$$

and the permissible contact stress is given by:

$$\sigma_{HP-B1} = \sigma_{H,lim} Z_{NT} Z_X Z_L Z_v Z_R Z_W Z_S Z_{Hyp} \quad (A.2)$$

For bevel gears without hypoid offset, the change from positive to negative specific sliding is exact on the pitch cone, which may be reduced to the mean point. Whether the critical point of load application for contact stress is above or below the mean point is decided by means of the mid-zone factor, Z_{M-B} (see [6.4.1](#)). With hypoid gears it is assumed that said change also takes place at the mean point. So, the bevel slip factor, Z_S , is determined for pinion and wheel depending on the mid-zone factor. In the range of $0,98 < Z_{M-B} < 1,0$ the bevel slip factor is interpolated (see [Figure A.1](#)). If the positive specific sliding applies to the pinion then the negative necessarily applies to the wheel and vice versa.

a) for $Z_{M-B} < 0,98$:

$$Z_{S1} = 1,175 ; Z_{S2} = 1,0 \quad (A.3)$$

b) for $Z_{M-B} > 1,00$:

$$Z_{S1} = 1,0 ; Z_{S2} = 1,175 \quad (A.4)$$

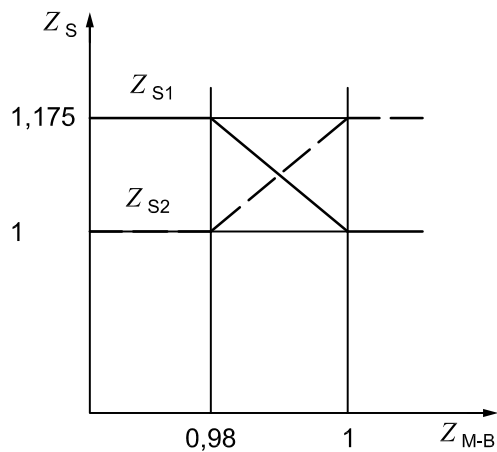

Key

Z_S bevel slip factor

Z_{M-B} mid-zone factor

Figure A.1 — Slip factor, $Z_{S1,2}$, for pitting resistance

Bibliography

- [1] ISO 6336-2, *Calculation of load capacity of spur and helical gears — Part 2: Calculation of surface durability (pitting)*
- [2] ISO 6336-6, *Calculation of load capacity of spur and helical gears — Part 6: Calculation of service life under variable load*
- [3] ISO/TR 10064-6, *Code of inspection practice — Part 6: Bevel gear measurement methods*
- [4] ISO/TR 22849, *Design recommendations for bevel gears*
- [5] ANSI/AGMA 2003-C10 *Rating the Pitting Resistance and Bending Strength of Generated Straight Bevel, Zerol Bevel and Spiral Bevel Gear Teeth*
- [6] AGMA 932-A05, *Rating the Pitting Resistance and Bending Strength of Hypoid Gears*

British Standards Institution (BSI)

BSI is the national body responsible for preparing British Standards and other standards-related publications, information and services.

BSI is incorporated by Royal Charter. British Standards and other standardization products are published by BSI Standards Limited.

About us

We bring together business, industry, government, consumers, innovators and others to shape their combined experience and expertise into standards-based solutions.

The knowledge embodied in our standards has been carefully assembled in a dependable format and refined through our open consultation process. Organizations of all sizes and across all sectors choose standards to help them achieve their goals.

Information on standards

We can provide you with the knowledge that your organization needs to succeed. Find out more about British Standards by visiting our website at bsigroup.com/standards or contacting our Customer Services team or Knowledge Centre.

Buying standards

You can buy and download PDF versions of BSI publications, including British and adopted European and international standards, through our website at bsigroup.com/shop, where hard copies can also be purchased.

If you need international and foreign standards from other Standards Development Organizations, hard copies can be ordered from our Customer Services team.

Subscriptions

Our range of subscription services are designed to make using standards easier for you. For further information on our subscription products go to bsigroup.com/subscriptions.

With **British Standards Online (BSOL)** you'll have instant access to over 55,000 British and adopted European and international standards from your desktop. It's available 24/7 and is refreshed daily so you'll always be up to date.

You can keep in touch with standards developments and receive substantial discounts on the purchase price of standards, both in single copy and subscription format, by becoming a **BSI Subscribing Member**.

PLUS is an updating service exclusive to BSI Subscribing Members. You will automatically receive the latest hard copy of your standards when they're revised or replaced.

To find out more about becoming a BSI Subscribing Member and the benefits of membership, please visit bsigroup.com/shop.

With a **Multi-User Network Licence (MUNL)** you are able to host standards publications on your intranet. Licences can cover as few or as many users as you wish. With updates supplied as soon as they're available, you can be sure your documentation is current. For further information, email bsmusales@bsigroup.com.

BSI Group Headquarters

389 Chiswick High Road London W4 4AL UK

Revisions

Our British Standards and other publications are updated by amendment or revision.

We continually improve the quality of our products and services to benefit your business. If you find an inaccuracy or ambiguity within a British Standard or other BSI publication please inform the Knowledge Centre.

Copyright

All the data, software and documentation set out in all British Standards and other BSI publications are the property of and copyrighted by BSI, or some person or entity that owns copyright in the information used (such as the international standardization bodies) and has formally licensed such information to BSI for commercial publication and use. Except as permitted under the Copyright, Designs and Patents Act 1988 no extract may be reproduced, stored in a retrieval system or transmitted in any form or by any means – electronic, photocopying, recording or otherwise – without prior written permission from BSI. Details and advice can be obtained from the Copyright & Licensing Department.

Useful Contacts:

Customer Services

Tel: +44 845 086 9001

Email (orders): orders@bsigroup.com

Email (enquiries): cservices@bsigroup.com

Subscriptions

Tel: +44 845 086 9001

Email: subscriptions@bsigroup.com

Knowledge Centre

Tel: +44 20 8996 7004

Email: knowledgecentre@bsigroup.com

Copyright & Licensing

Tel: +44 20 8996 7070

Email: copyright@bsigroup.com



...making excellence a habit.™