

Earth-moving machinery — Operator enclosure environment

**Part 4: Heating, ventilating and air
conditioning (HVAC) test method and
performance**

ICS 53.100

National foreword

This British Standard is the UK implementation of ISO 10263-4:2009. It supersedes BS 6912-22.4:1996 which is withdrawn.

The UK participation in its preparation was entrusted to Technical Committee B/513/1, Earth moving machinery (International).

A list of organizations represented on this committee can be obtained on request to its secretary.

This publication does not purport to include all the necessary provisions of a contract. Users are responsible for its correct application.

Compliance with a British Standard cannot confer immunity from legal obligations.

This British Standard was published under the authority of the Standards Policy and Strategy Committee on 30 April 2009

© BSI 2009

ISBN 978 0 580 57408 5

Amendments/corrigenda issued since publication

Date	Comments

**Earth-moving machinery — Operator
enclosure environment —**

Part 4:
**Heating, ventilating and air conditioning
(HVAC) test method and performance**

*Engins de terrassement — Environnement de l'enceinte de
l'opérateur —*

*Partie 4: Performances et méthode d'essai des systèmes de chauffage,
de ventilation et de climatisation (CVCA)*



PDF disclaimer

This PDF file may contain embedded typefaces. In accordance with Adobe's licensing policy, this file may be printed or viewed but shall not be edited unless the typefaces which are embedded are licensed to and installed on the computer performing the editing. In downloading this file, parties accept therein the responsibility of not infringing Adobe's licensing policy. The ISO Central Secretariat accepts no liability in this area.

Adobe is a trademark of Adobe Systems Incorporated.

Details of the software products used to create this PDF file can be found in the General Info relative to the file; the PDF-creation parameters were optimized for printing. Every care has been taken to ensure that the file is suitable for use by ISO member bodies. In the unlikely event that a problem relating to it is found, please inform the Central Secretariat at the address given below.

**COPYRIGHT PROTECTED DOCUMENT**

© ISO 2009

All rights reserved. Unless otherwise specified, no part of this publication may be reproduced or utilized in any form or by any means, electronic or mechanical, including photocopying and microfilm, without permission in writing from either ISO at the address below or ISO's member body in the country of the requester.

ISO copyright office
Case postale 56 • CH-1211 Geneva 20
Tel. + 41 22 749 01 11
Fax + 41 22 749 09 47
E-mail copyright@iso.org
Web www.iso.org

Published in Switzerland

Contents

Page

Foreword.....	iv
1 Scope	1
2 Normative references	1
3 Terms and definitions.....	1
4 Test equipment and instruments	2
5 Measurement locations	2
6 Heating, ventilating and air conditioning system.....	3
7 Air conditioning systems	4
8 Heating system	5
9 Ventilating system	6
10 Test report	6
Annex A (informative) Example of test report form for operator enclosure air conditioning, heating and ventilating systems	7
Bibliography	9

Foreword

ISO (the International Organization for Standardization) is a worldwide federation of national standards bodies (ISO member bodies). The work of preparing International Standards is normally carried out through ISO technical committees. Each member body interested in a subject for which a technical committee has been established has the right to be represented on that committee. International organizations, governmental and non-governmental, in liaison with ISO, also take part in the work. ISO collaborates closely with the International Electrotechnical Commission (IEC) on all matters of electrotechnical standardization.

International Standards are drafted in accordance with the rules given in the ISO/IEC Directives, Part 2.

The main task of technical committees is to prepare International Standards. Draft International Standards adopted by the technical committees are circulated to the member bodies for voting. Publication as an International Standard requires approval by at least 75 % of the member bodies casting a vote.

Attention is drawn to the possibility that some of the elements of this document may be the subject of patent rights. ISO shall not be held responsible for identifying any or all such patent rights.

ISO 10263-4 was prepared by Technical Committee ISO/TC 127, *Earth-moving machinery*, Subcommittee SC 2, *Safety, ergonomics and general requirements*.

This second edition cancels and replaces the first edition (ISO 10263-4:1994), which has been technically revised.

ISO 10263 consists of the following parts, under the general title *Earth-moving machinery — Operator enclosure environment*:

- *Part 1: Terms and definitions*
- *Part 2: Air filter element test method*
- *Part 3: Pressurization test method*
- *Part 4: Heating, ventilating and air conditioning (HVAC) test method and performance*
- *Part 5: Windscreen defrosting system test method*
- *Part 6: Determination of effect of solar heating*

Earth-moving machinery — Operator enclosure environment —

Part 4:

Heating, ventilating and air conditioning (HVAC) test method and performance

1 Scope

This part of ISO 10263 specifies a uniform test method for measuring the contribution to operator environmental temperature provided by a heating, ventilating and air conditioning system operating in a specific ambient environment. The method might not determine the complete climatic environment of the operator since this is also affected by heat load from sources other than those on the machine, for example solar heating. ISO 10263-6 is to be used in conjunction with this part of ISO 10263 to determine more accurately the complete heat loading on the operator enclosure. Minimum performance levels for the machine's operator enclosure heating, ventilating and air conditioning systems are established in this part of ISO 10263.

NOTE The HVAC is also referred to as the climate control system.

2 Normative references

The following referenced documents are indispensable for the application of this document. For dated references, only the edition cited applies. For undated references, the latest edition of the referenced document (including any amendments) applies.

ISO 5353:1995, *Earth-moving machinery, and tractors and machinery for agriculture and forestry — Seat index point*

ISO 9249:2007, *Earth-moving machinery — Engine test code — Net power*

ISO 10263-1, *Earth-moving machinery — Operator enclosure environment — Part 1: Terms and definitions*

ISO 10263-2, *Earth-moving machinery — Operator enclosure environment — Part 2: Air filter element test method*

ISO 10263-3, *Earth-moving machinery — Operator enclosure environment — Part 3: Pressurization test method*

ISO 10263-6, *Earth-moving machinery — Operator enclosure environment — Part 6: Determination of effect of solar heating*

3 Terms and definitions

For the purposes of this document, the terms and definitions given in ISO 10263-1 and the following apply.

- 3.1 operator enclosure**
part of the machine which completely surrounds the operator, preventing the free passage of external air, dust or other substances into the area around the operator
- 3.2 operator environment**
space surrounding the operator defined by temperature and wind speed measurement points
- 3.3 air conditioning system**
system which lowers the effective temperature of the air within the operator enclosure
- 3.4 heating system**
system which raises the effective temperature of the air within the operator enclosure
- 3.5 ventilating system**
system which provides fresh air to, and maintains air circulation within, the operator enclosure

4 Test equipment and instruments

4.1 Test enclosure sufficiently large to contain the base machine with provision to circulate conditioned air and to load the machine engine and transmission if required.

Field test conditions may be used.

If it is not practical to test the base machine due to physical size limitations, the operator enclosure may be bench-tested with the loads imposed by the base machine on the operator enclosure simulated. If this procedure is used, correlation with field data shall be established.

- 4.2 Thermometers or other temperature measuring devices**, with a measuring accuracy of $\pm 0,5$ °C
- 4.3 Device to measure wet bulb or dew point temperature**, with a measuring accuracy of $\pm 0,5$ °C.
- 4.4 Device to measure operator enclosure pressure (Pa)**, with a measuring accuracy of 5 % of the observed values.
- 4.5 Device to measure rotational frequency (rpm)**, with a measuring accuracy of 2 % of the observed values.
- 4.6 Anemometer** to measure wind speed, with a measuring accuracy of within 0,5 m/s.
- 4.7 Stopwatch or other timing device.**

5 Measurement locations

5.1 General

The locations of the temperature and wind speed measurement points shall be based on the seat index point, described in ISO 5353. See Figure 1.

5.2 Measurement specifications

5.2.1 The ambient outside air temperature shall be measured at a location where it is not affected by the machine and at a height equivalent to the air intake height on the operator enclosure.

5.2.2 The operator enclosure pressurization shall be measured in accordance with ISO 10263-3.

5.2.3 The inside dry bulb temperature shall be measured as close as practical to point 1 to point 6 as shown in Figure 1.

If an alternative operator station position is available (for example, in a backhoe loader machine), the alternative position should also be tested with a comparable array of temperature-measurement points.

5.2.4 It is recommended that the wind speed be measured at the operator eye point (point 7 in Figure 1).

If an alternative operator station position is available (for example, in a backhoe loader machine), the alternative position should also be tested at a comparable operator eye point.

6 Heating, ventilating and air conditioning system

6.1 Common test conditions

6.1.1 The operator enclosure shall be capable of being pressurized at a minimum pressure level of 50 Pa, but not exceeding 200 Pa, and shall be maintained at this level throughout the test.

6.1.2 Under all conditions of heating, ventilating or air conditioning, a minimum of 43 m³/h of filtered fresh air shall be provided.

6.1.3 At the conclusion of heating, ventilating or air conditioning tests, the temperatures measured (point 1 to point 6, see Figure 1) in the operator's environment shall not vary by more than 5 °C.

6.1.4 Filtered fresh air shall be passed through a filter that is a minimum of 96 % efficient, using fine test dust and the test method specified in ISO 10263-2.

6.1.5 It is recommended that a means be provided to limit the maximum wind speed at point 7 in Figure 1 to 0,3 m/s. Adjustable diffusers may be used to redirect air.

6.1.6 Test conditions shall be maintained throughout the duration of the test.

6.1.7 The maximum wind speed passing the machine from front to rear is 5 m/s.

6.2 Common test procedure

6.2.1 The test conditions specified in 7.1, 8.1 and 9.1 shall be maintained throughout the duration of the respective test.

6.2.2 Record enclosure pressure, in Pascals (Pa). The pressure measuring device shall be positioned to avoid velocity head by keeping its reference and measuring points away from air streams.

6.2.3 Record the temperatures as specified in 5.2.3 at intervals not greater than 5 min.

6.2.4 The average dry bulb temperatures from point 1 to point 6 shall be determined for each reading interval.

6.2.5 The test shall be considered terminated when either of the following conditions has been fulfilled:

- a) the average dry bulb temperature recorded in 6.2.3 does not vary by more than 0,5 °C in 15 min;
- b) the test has run for 1 h.

6.2.6 An operator may be present in the operator enclosure throughout the duration of the test.

Dimensions in millimetres

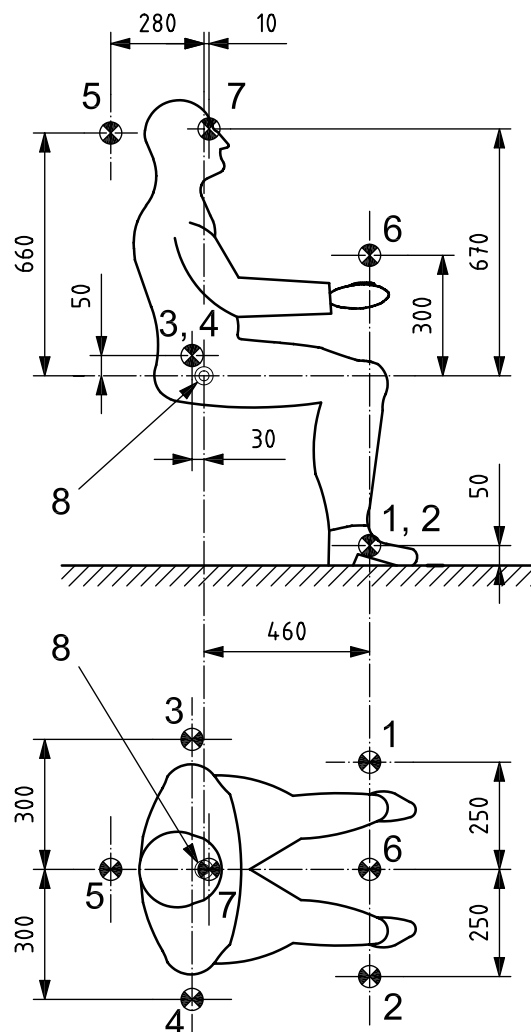
**Key**

- 1–6 temperature and wind speed measurement points
- 7 operator eye point
- 8 SIP

Figure 1 — Measurement point locations**7 Air conditioning systems****7.1 Test conditions**

7.1.1 The air conditioning system shall be tested in its intended production configuration, adjusted within the manufacturer's specifications.

7.1.2 The ambient conditions shall be:

- a) minimum dry bulb temperature: + 38 °C;
- b) minimum moisture content of 0,018 kg H₂O per kg dry air at or above 38 °C.

7.1.3 When the environment within the operator enclosure is influenced by engine or component temperatures (such as transmission) the machine shall be operated at rated engine speed in a mode which will provide at least 50 % of the maximum rated net engine power, determined in accordance with ISO 9249 or these conditions shall be simulated as referenced in 4.1. Loading of the engine through the transmission is recommended.

7.1.4 The air conditioning system controls shall be set according to the manufacturer's specifications or to provide maximum cooling performance. The requirements specified in 6.1 shall be maintained throughout the test.

7.1.5 Prior to conducting tests on the air conditioning system, the machine shall be operated for 1 h in accordance with 7.1.3, with the air conditioning system not in use to provide a preliminary, stabilizing heat soak period. During this period, the ambient temperature shall be as specified in 7.1.2.

7.1.6 It is recommended that solar loading be applied in accordance with ISO 10263-6. The loading shall be applied in one of the following time periods.

- If the machine or operator enclosure is heat soaked using the engine as defined in 7.1.5, the solar loading is to start at the beginning of the air conditioning tests. Solar loading before the air conditioning tests is allowable.
- If the machine or operator enclosure is not heat soaked as defined in 7.1.5, the solar loading is to begin a minimum of 1 h prior to conducting the air conditioning tests. Doors and windows shall be closed. During this period, ambient temperature shall be as specified in 7.1.2.

7.2 Minimal air conditioning performance

The air conditioning system shall be capable of reducing the operator environment dry bulb temperature to 25 °C or lower.

8 Heating system

8.1 Test conditions

8.1.1 The heating system shall be tested in the intended production configuration, adjusted within the manufacturer's specifications.

8.1.2 The maximum ambient temperature for the heating system test shall be –15 °C or colder.

8.1.3 Before carrying out the tests, the machine shall be cold soaked at the temperature specified in 8.1.2 for 10 h or until the heat transfer medium, the windshield, the HVAC system, the duct work and the enclosure are at the temperature specified in 8.1.2. No external oil or coolant heating source shall be used during the cold soak.

8.1.4 The machine shall be operated in accordance with the manufacturer's recommended warm-up practice and then run at rated speed under a maximum load of no more than 20 % of the maximum rated net engine power, as determined in accordance with ISO 9249, or these conditions shall be simulated as referenced in 4.1.

8.1.5 The heating system controls shall be set in accordance with the manufacturer's instructions or be adjusted to provide maximum operator enclosure pressurization.

8.2 Minimum heating performance

The heating system shall be capable of increasing the operator environment temperature to 25 °C or greater.

9 Ventilating system

9.1 Test conditions

9.1.1 The ventilating system shall be tested in its intended production configuration, adjusted within the manufacturer's specifications.

9.1.2 The ambient conditions for the ventilating system test shall be a minimum outside dry bulb temperature of 27 °C.

9.1.3 The machine shall be operated in accordance with the manufacturer's recommended warm-up procedure, and then run at the rated speed under a maximum load of no more than 20 % of the maximum rated net engine power, as determined in accordance with ISO 9249 or these conditions shall be simulated as referenced in 4.1.

9.1.4 The ventilating system controls shall be adjusted to the maximum position with maximum operator enclosure pressurization.

9.2 Minimum ventilating performance

The minimum ventilating performance requirements shall be as indicated in 6.1.

10 Test report

The test report shall include the following information:

- a) model and serial number of machine tested;
- b) ambient conditions outside the operator enclosure [i.e. dry bulb temperature, moisture content (kg H₂O per kg dry air), wind speed];
- c) operator enclosure pressurization (Pa);
- d) average dry bulb temperature in the operator enclosure at the end of the test (°C);
- e) operator environment temperature uniformity;
- f) volume of fresh filtered air provided;
- g) solar radiant energy levels as measured in accordance with ISO 10263-6.

In addition, the optional test conditions shall be recorded when they are used.

An example of a suitable test report form is given in Annex A.

Annex A (informative)

Example of test report form for operator enclosure air conditioning, heating and ventilating systems

Test machine

Type: Model: PIN (or serial number):

Air conditioning system test (Clause 7)

Ambient conditions

Dry bulb temperature: °C

Moisture content: kg H₂O per kg dry air

Wind speed passing machine (6.1.7): m/s

Operator environment temperature at end of test

Dry bulb temperature (average): °C

Operator environment temperature uniformity (6.1.3): Δ °C

Minimum performance achieved (7.2): yes/no

Enclosure pressure: Pa

Setting of adjustable controls:

Solar heating: natural simulated none

solar radiant energy: W/m²

Method of engine loading (if applicable):

Duration of test: min

Heating system test (Clause 8)

Ambient dry bulb temperature: °C

Wind speed passing machine (6.1.7): m/s

Operator environment dry bulb temperature at end of test (average): °C

Operator environment temperature uniformity (6.1.3): Δ °C

Minimum performance achieved (8.2): yes/no

Enclosure pressure: Pa

BS ISO 10263-4:2009
ISO 10263-4:2009(E)

Setting of adjustable controls:

Method of engine loading (if applicable):

Duration of test: min

Ventilating test (Clause 9)

Ambient dry bulb temperature: °C

Wind speed passing machine (6.1.7): m/s

Operator environment temperature uniformity (6.1.3): Δ °C

Minimum performance achieved (9.2): yes/no

Enclosure pressure: Pa

Setting of adjustable controls:

Solar heating: natural simulated none

Solar radiant energy: W/m²

Method of engine loading (if applicable):

Duration of test: min

Bibliography

- [1] ISO 5006, *Earth-moving machinery — Operator's field of view — Test method and performance criteria*

BS ISO 10263-4:2009
ISO 10263-4:2009(E)

ICS 53.100

Price based on 9 pages

BSI - British Standards Institution

BSI is the independent national body responsible for preparing British Standards. It presents the UK view on standards in Europe and at the international level. It is incorporated by Royal Charter.

Revisions

British Standards are updated by amendment or revision. Users of British Standards should make sure that they possess the latest amendments or editions.

It is the constant aim of BSI to improve the quality of our products and services. We would be grateful if anyone finding an inaccuracy or ambiguity while using this British Standard would inform the Secretary of the technical committee responsible, the identity of which can be found on the inside front cover. Tel: +44 (0)20 8996 9000. Fax: +44 (0)20 8996 7400.

BSI offers members an individual updating service called PLUS which ensures that subscribers automatically receive the latest editions of standards.

Buying standards

Orders for all BSI, international and foreign standards publications should be addressed to Customer Services. Tel: +44 (0)20 8996 9001. Fax: +44 (0)20 8996 7001 Email: orders@bsigroup.com You may also buy directly using a debit/credit card from the BSI Shop on the Website <http://www.bsigroup.com/shop>

In response to orders for international standards, it is BSI policy to supply the BSI implementation of those that have been published as British Standards, unless otherwise requested.

Information on standards

BSI provides a wide range of information on national, European and international standards through its Library and its Technical Help to Exporters Service. Various BSI electronic information services are also available which give details on all its products and services. Contact Information Centre. Tel: +44 (0)20 8996 7111 Fax: +44 (0)20 8996 7048 Email: info@bsigroup.com

Subscribing members of BSI are kept up to date with standards developments and receive substantial discounts on the purchase price of standards. For details of these and other benefits contact Membership Administration. Tel: +44 (0)20 8996 7002 Fax: +44 (0)20 8996 7001 Email: membership@bsigroup.com

Information regarding online access to British Standards via British Standards Online can be found at <http://www.bsigroup.com/BSOL>

Further information about BSI is available on the BSI website at <http://www.bsigroup.com>

Copyright

Copyright subsists in all BSI publications. BSI also holds the copyright, in the UK, of the publications of the international standardization bodies. Except as permitted under the Copyright, Designs and Patents Act 1988 no extract may be reproduced, stored in a retrieval system or transmitted in any form or by any means – electronic, photocopying, recording or otherwise – without prior written permission from BSI.

This does not preclude the free use, in the course of implementing the standard, of necessary details such as symbols, and size, type or grade designations. If these details are to be used for any other purpose than implementation then the prior written permission of BSI must be obtained.

Details and advice can be obtained from the Copyright and Licensing Manager. Tel: +44 (0)20 8996 7070 Email: copyright@bsigroup.com